

# LUDLOW 2 DOOR WARDROBE WHITE ASSEMBLY INSTRUCTIONS

55701

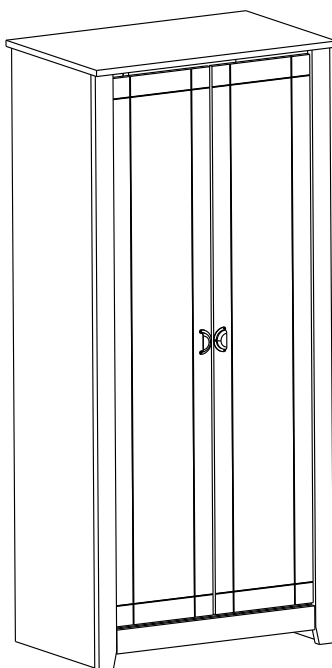

## IMPORTANT FOR DOMESTIC USE ONLY

PLEASE READ BEFORE YOU CONTINUE FURTHER

## CARE AND MAINTENANCE

After unpacking this product please keep the original packaging in case it needs to be returned for any reason.

- Please ensure all fittings and parts are present before commencing with assembly.
- Never drag or push products as this could cause damage to the joints making it inferior.
- We strongly recommend that you keep children away from your work area.
- We recommend that you lay a blanket or sheet on the floor to avoid damage to both your floor and the product.
- Assemble this product as close to its final position as possible.
- Do not place this product next to a radiator or in direct sunlight.
- Do not drag or push items across your high gloss furniture as this may cause the surface to scratch
- Wood is a natural product and may expand if subjected to damp and may shrink or crack if subjected to heat. Therefore it is recommended that room temperature is maintained, with no sudden temperature fluctuations.
- Make sure any spillage is wiped off immediately.
- Do not place hot or chilled items directly on to the surface, use a place mat or marking will occur.
- For general cleaning use a soft cotton or micro fibre cloth, and do not use detergents of any kind.
- From time to time it may be necessary to tighten fittings, regular inspections should be carried out.
- Do not place on a wet or damp floor as staining may occur to your floor.

**TOOLS REQUIRED**

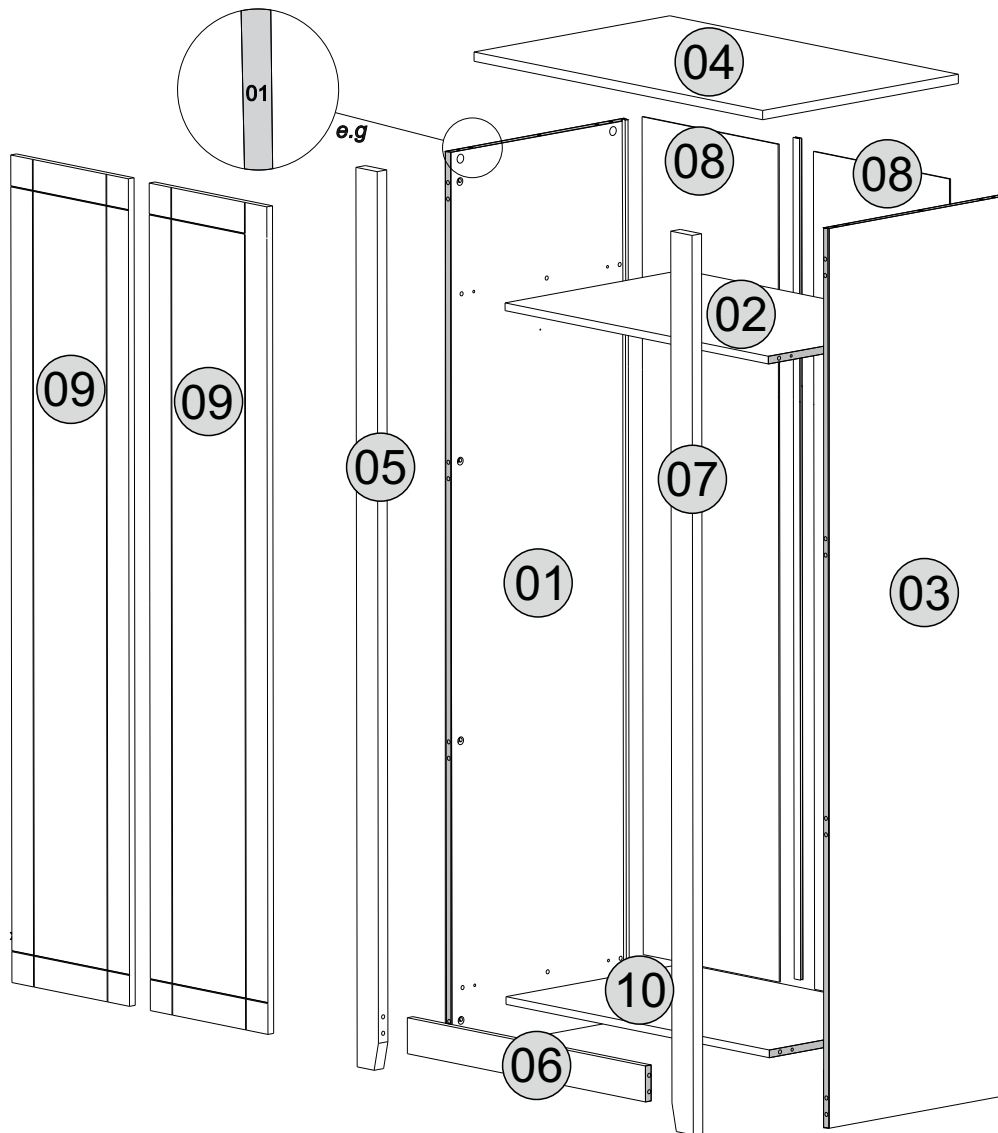
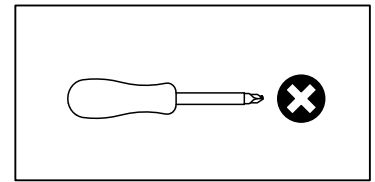
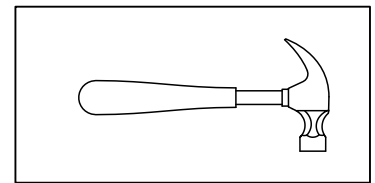





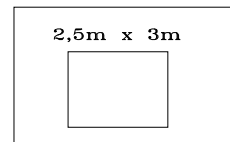



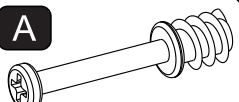
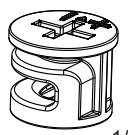
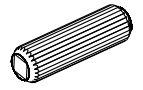

**PARTS LIST**

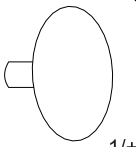
**Please Note:**  
The below parts have been stamped with the part number to help identify them during assembly.

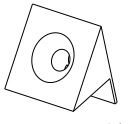

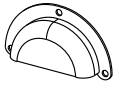
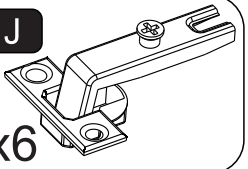
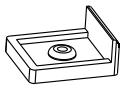
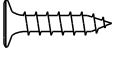
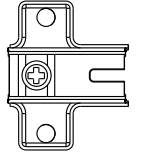
Part Number	Part Code	Part Description	Quantity	Carton
01	S100-101-065-DV1-01	Left Side Panel	1	2/2
02	S100-101-065-DV1-02	Shelf	1	2/2
03	S100-101-065-DV1-03	Right Side Panel	1	2/2
04	S100-101-065-DV1-04	Top Panel	1	1/2
05	S100-101-065-DV1-05	Front Left Upright	1	1/2
06	S100-101-065-DV1-06	Crossbeam	1	1/2
07	S100-101-065-DV1-07	Front Right Upright	1	1/2
08	S100-101-065-DV1-08	Back Panel	1	2/2
09	S100-101-065-DV1-10	Door	2	1/2
10	S100-101-065-DV1-11	Base	1	2/2

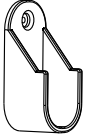
### FITTINGS LIST

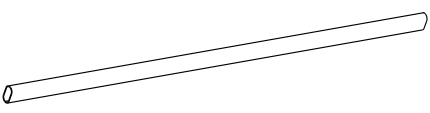
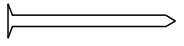
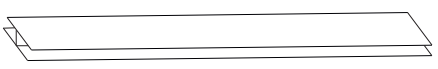
<b>A</b> x20 1/+ 	<b>B</b> x20 1/+ 	<b>C</b> x30 8x30mm 2/+ 	<b>D</b> x1 GLUE 	<b>E</b> x14 1/+ 
<b>F</b> x1 22x22 	<b>G</b> x20 2/+ 	<b>H</b> x6 1/+ Ø3,0 x 10 Black 	<b>I</b> x2 	<b>J</b> x6 
<b>K</b> x4 1/+ 	<b>L</b> x20 2/+ Ø3,5 x 16 	<b>M</b> x6 	<b>N</b> x30 2/+ Ø3,5 x 14 	<b>O</b> x2 
<b>P</b> x1 SAFETY KIT 	<b>Q</b> x1 	<b>R</b> x10 10x10 		
<b>S</b> Plastic profile 1600mm (1x) 				

## TIPS FOR FITTING CAM-LOCKS

WHEN FITTING CAM-LOCK  
ENSURE STARTING POSITION IS CORRECT  
BEFORE YOU INSERT CONNECTING CAM BOLT  
TURN CLOCKWISE UNTIL SECURE

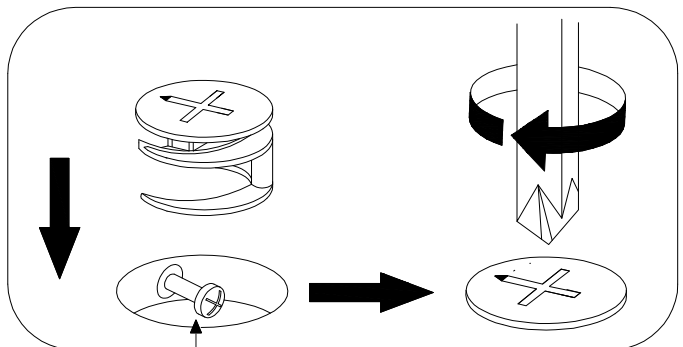
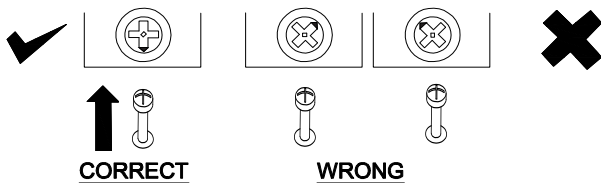

**Cam bolt head needs to be in centre**

### CAMBOLT

**Tighten until shoulder is flush with panel. Do not overtighten or undertighten (see example below)**

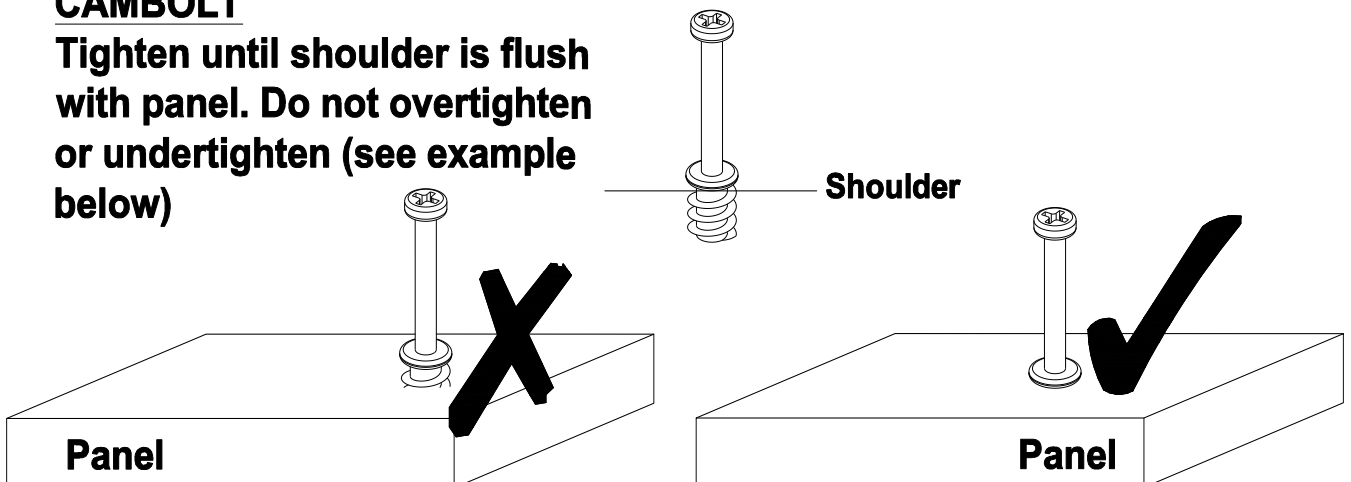

# STEP 1

## PARTS REQUIRED

01- LEFT SIDE PANEL x1

03- RIGHT SIDE PANEL x1

## HARDWARE REQUIRED

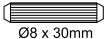
C  06  
Ø8 x 30mm

D  01  
GLUE

## TOOLS REQUIRED

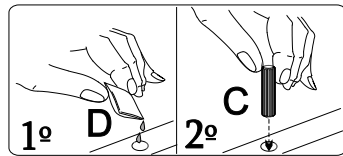
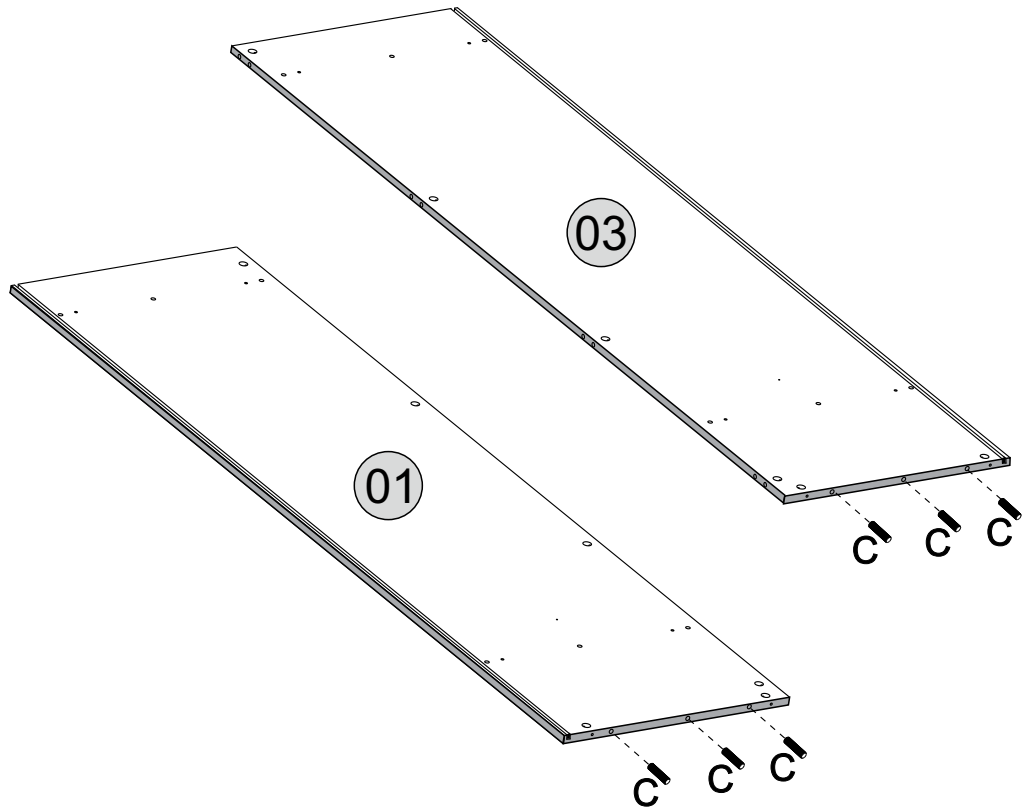

**!**  
Glue must be added to the dowel holes on part 01 and 03.

# STEP 2

## PARTS REQUIRED

02- SHELF x1

04- TOP PANEL x1

10- BASE x1

## HARDWARE REQUIRED

A  04

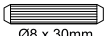
C  12  
Ø8 x 30mm

D  01  
GLUE

## TOOLS REQUIRED

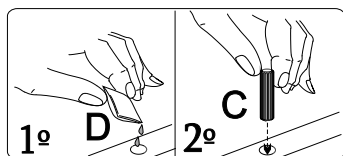
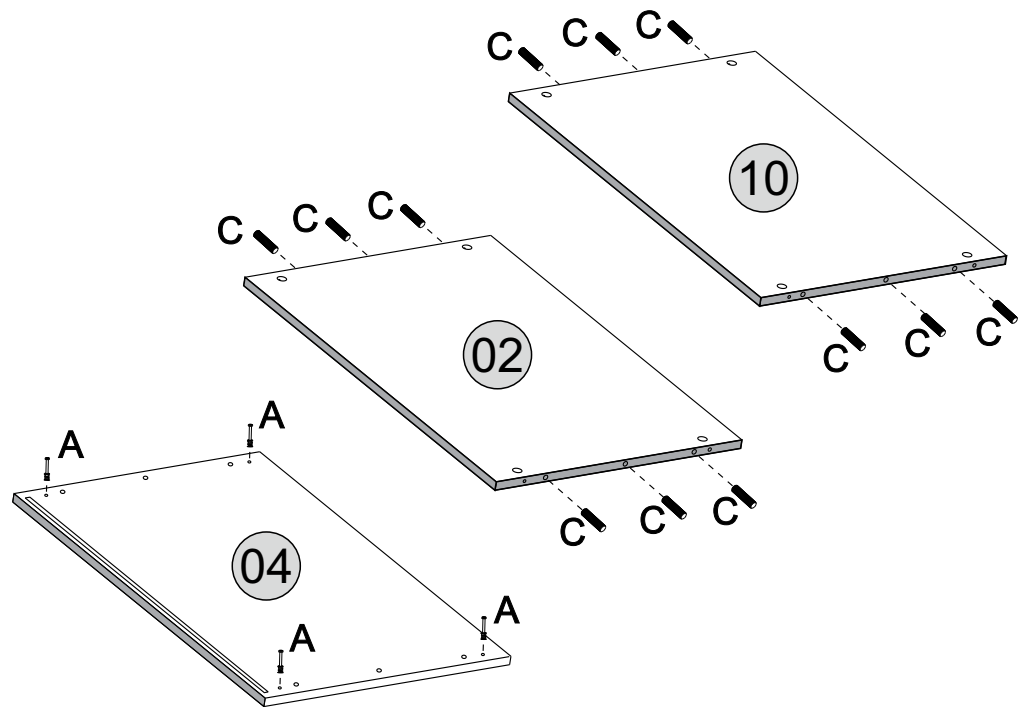
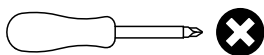

**!**  
Glue must be added to the dowel holes on part 02 and 11.

# STEP 3

## PARTS REQUIRED

01- LEFT SIDE PANEL x1

## HARDWARE REQUIRED

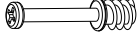
A  04

K  02

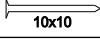
R  10x10 02

## TOOLS REQUIRED

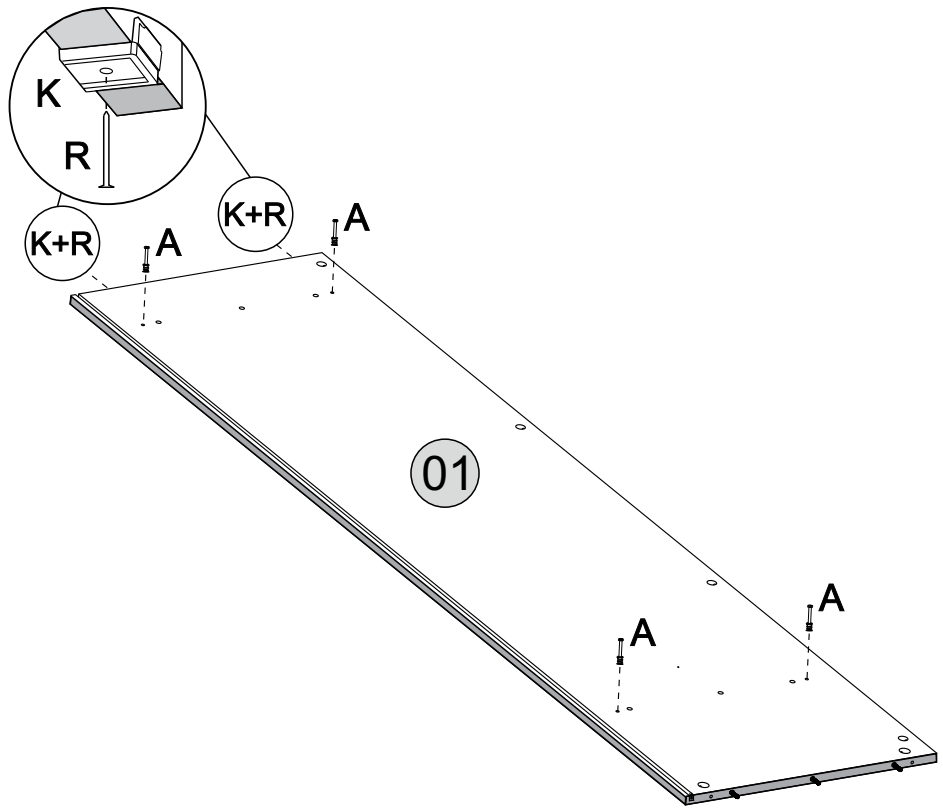
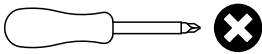
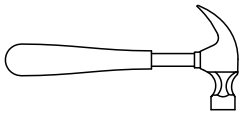

# STEP 4

## PARTS REQUIRED

03- RIGHT SIDE PANEL x1

## HARDWARE REQUIRED

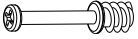
A  04

K  02

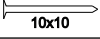
R  10x10 02

## TOOLS REQUIRED

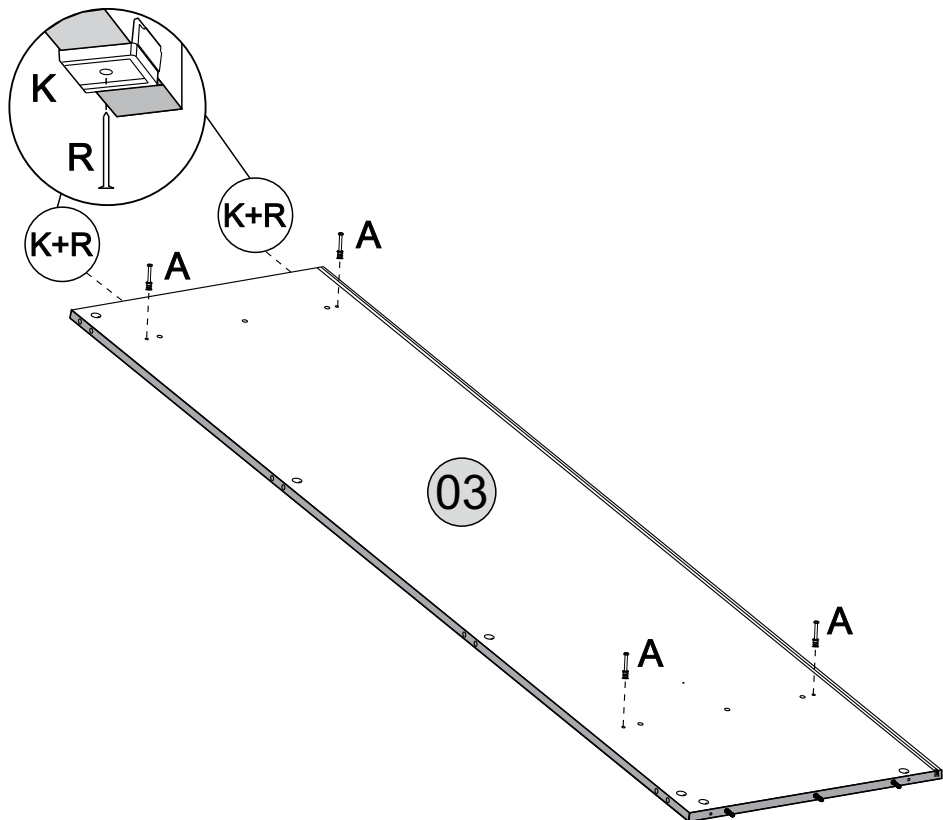
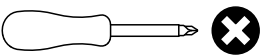
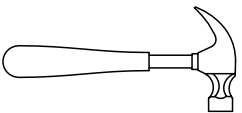



# STEP 5

## PARTS REQUIRED

- 05- FRONT LEFT UPRIGHT x1
- 06- CROSSBEAM x1
- 07- FRONT RIGHT UPRIGHT x1

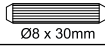
## HARDWARE REQUIRED

- C  12  
Ø8 x 30mm
- D  01

## TOOLS REQUIRED

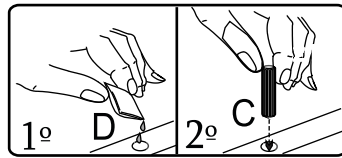

**!**  
Glue must be added to the  
dowel holes on part  
05, 06 and 07.

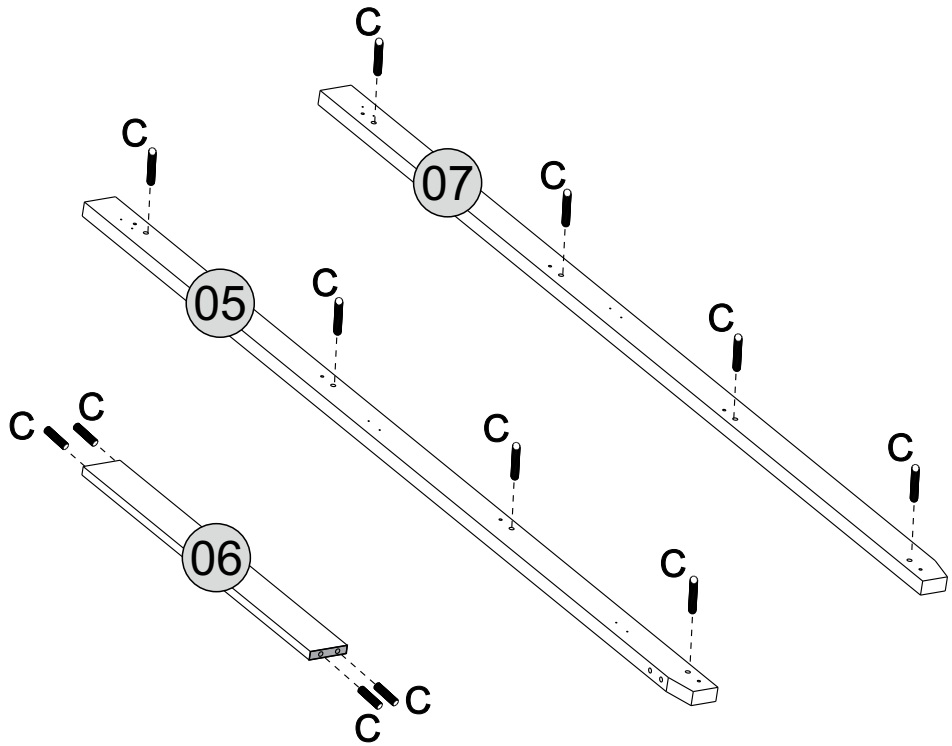



# STEP 6

## PARTS REQUIRED

- 05- FRONT LEFT UPRIGHT x1
- 07- FRONT RIGHT UPRIGHT x1

## HARDWARE REQUIRED

- A  08
- M  06
- N  12  
Ø3,5 x 14

## TOOLS REQUIRED

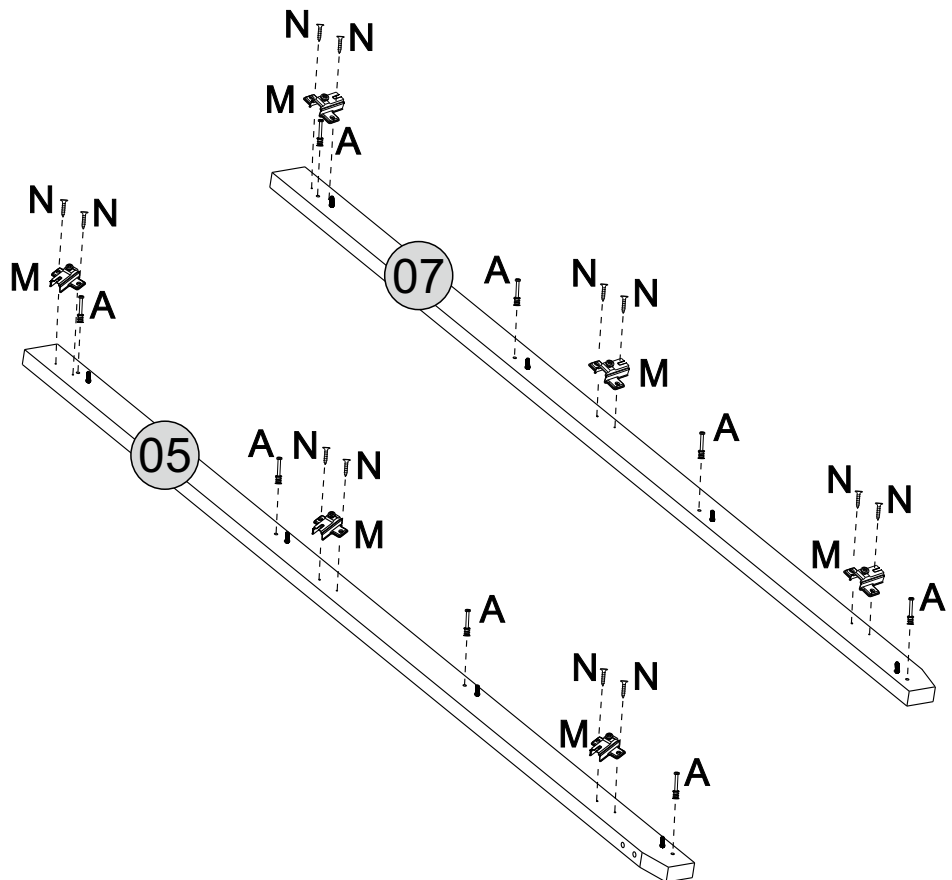
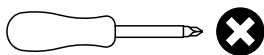

# STEP 7

## PARTS REQUIRED

01- LEFT SIDE PANEL x1

02- SHELF x1

03- RIGHT SIDE PANEL x1

10- BASE x1

## HARDWARE REQUIRED

B  08

D  01

E  04

## TOOLS REQUIRED

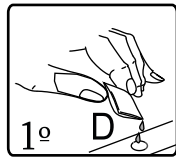
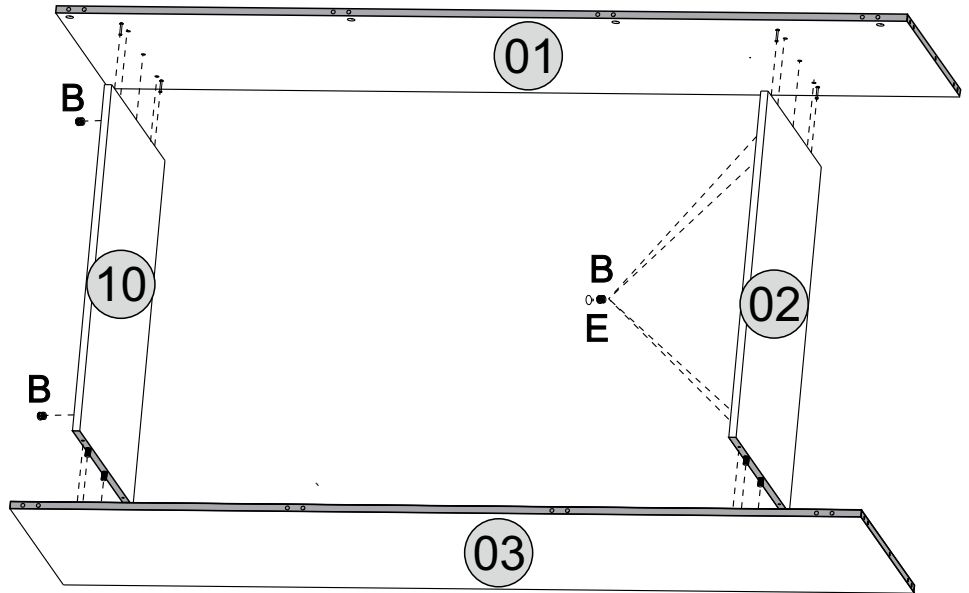
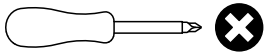

**!**  
Glue must be added to the  
dowel holes on part  
01 and 03.

**!**  
Please refer to  
page 03 on how  
to use cams  
correctly.

# STEP 8

## PARTS REQUIRED

04- TOP PANEL x1

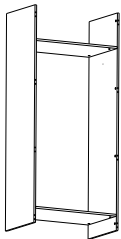

## HARDWARE REQUIRED

B  04

D  01

E  04

## TOOLS REQUIRED

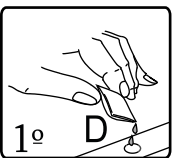
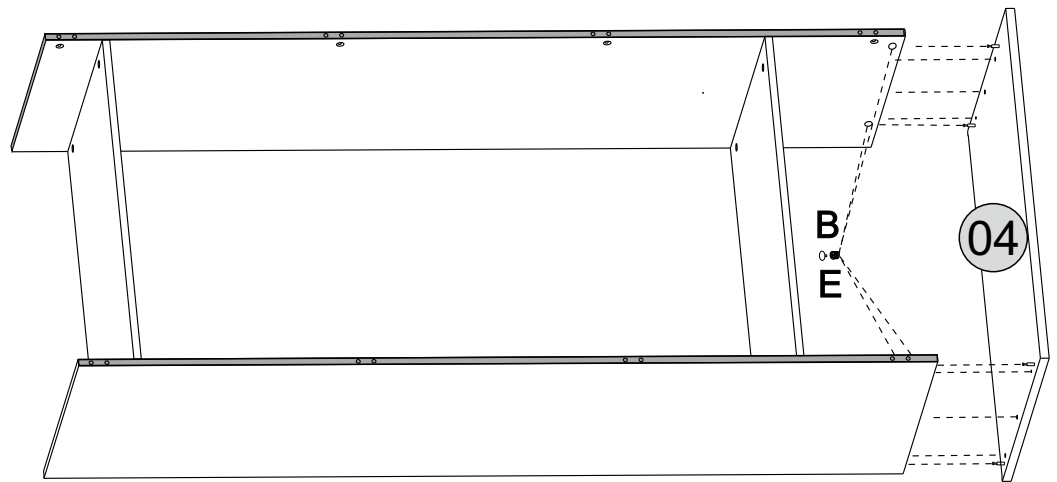
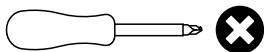

**!**  
Glue must be added to the  
dowel holes on part  
04.

**!**  
Please refer to  
page 03 on how  
to use cams  
correctly.

# STEP 9

## PARTS REQUIRED

08- BACK PANEL x2

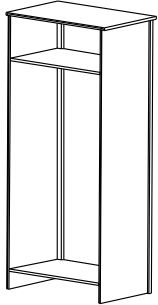

## HARDWARE REQUIRED

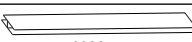
S  01  
1600mm

## TOOLS REQUIRED

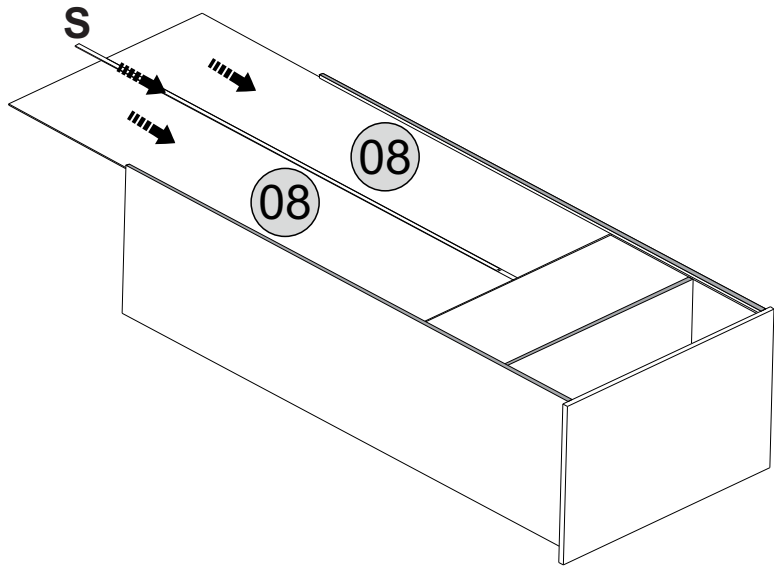

# STEP 10

## PARTS REQUIRED

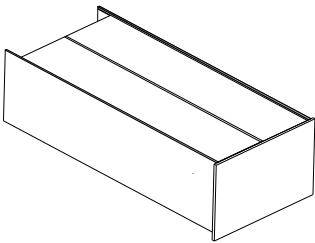

## HARDWARE REQUIRED

G  20

L  20

R  10x10 06

## TOOLS REQUIRED

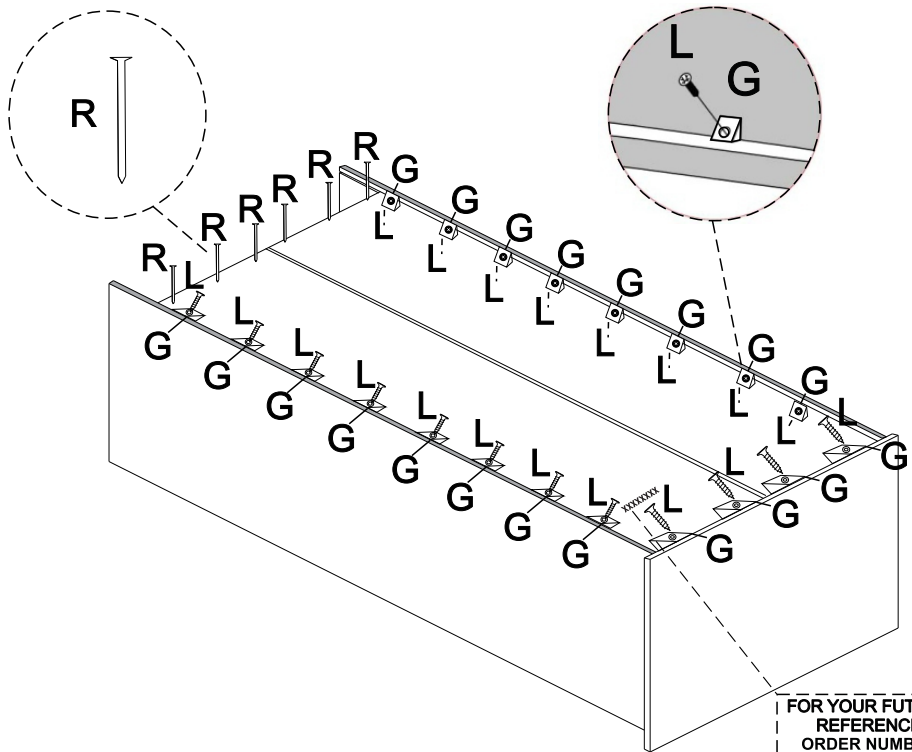
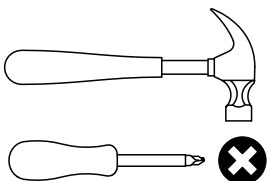

FOR YOUR FUTURE  
REFERENCE  
ORDER NUMBER  
SHOULD BE HERE

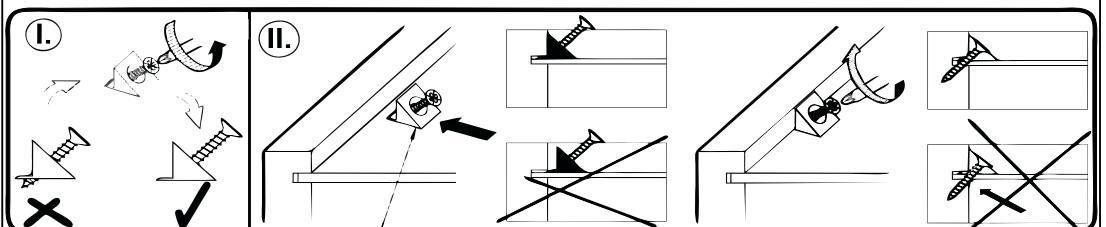



# STEP 11

## PARTS REQUIRED

05- FRONT LEFT UPRIGHT x1

06- CROSSBEAM x1

07- FRONT RIGHT UPRIGHT x1

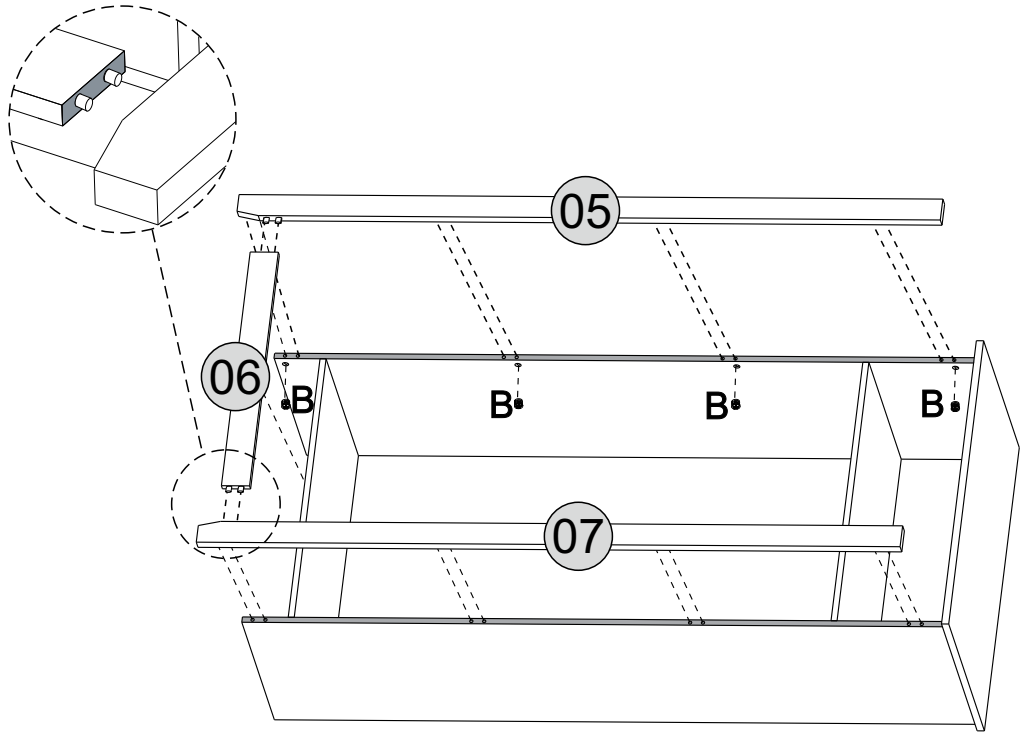
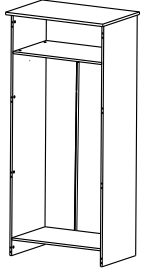

## HARDWARE REQUIRED

B  08

D  01

## TOOLS REQUIRED

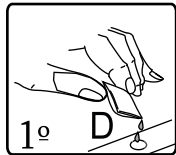
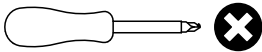

**!**  
Glue must be added to the dowel holes on part 01 and 03.

# STEP 12

## PARTS REQUIRED

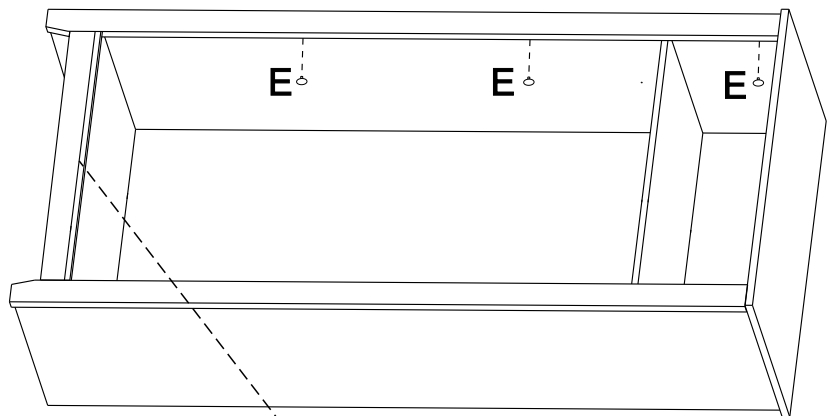
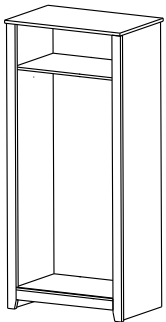

## HARDWARE REQUIRED

E  06

F  01

N  02  
Ø3,5 x 14

## TOOLS REQUIRED

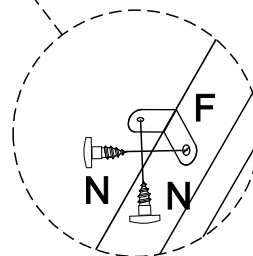
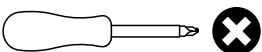

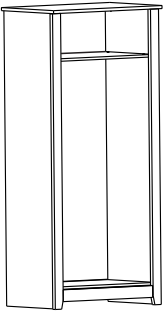

# STEP 13

**PARTS REQUIRED**



**HARDWARE REQUIRED**

N	 Ø3,5 x 14	04
O		02
Q		01

**TOOLS REQUIRED**

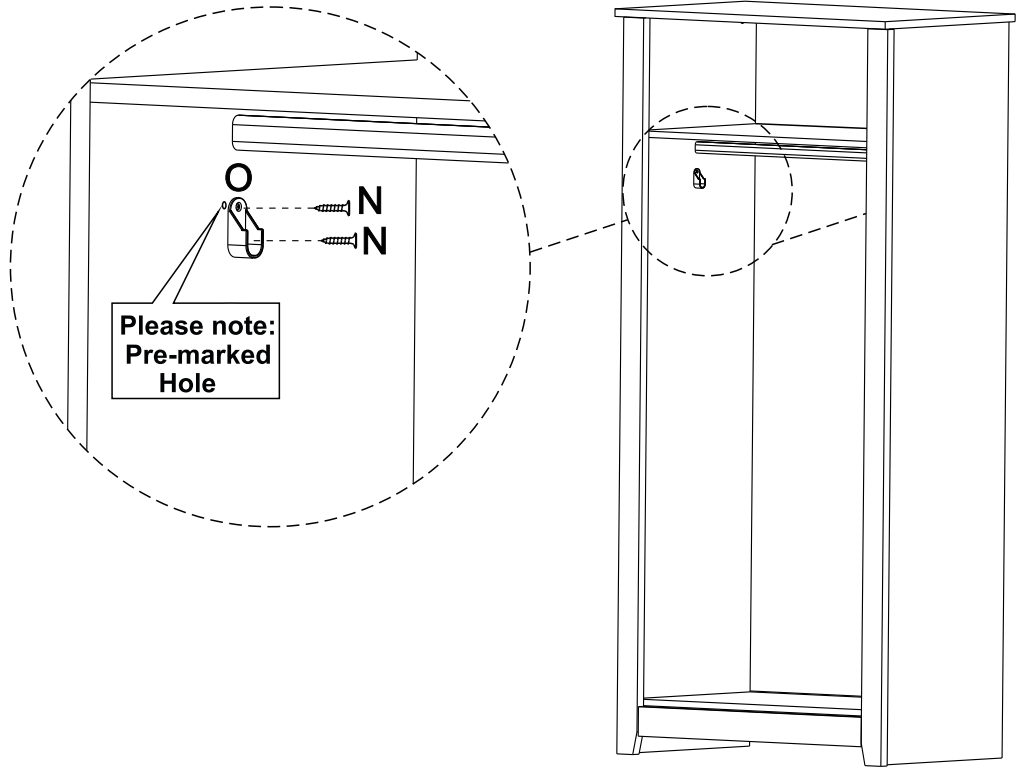
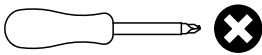



# STEP 14

**PARTS REQUIRED**

09- DOOR	x2
----------	----

**HARDWARE REQUIRED**

J		06
N	 Ø3,5 x 14	12

**TOOLS REQUIRED**

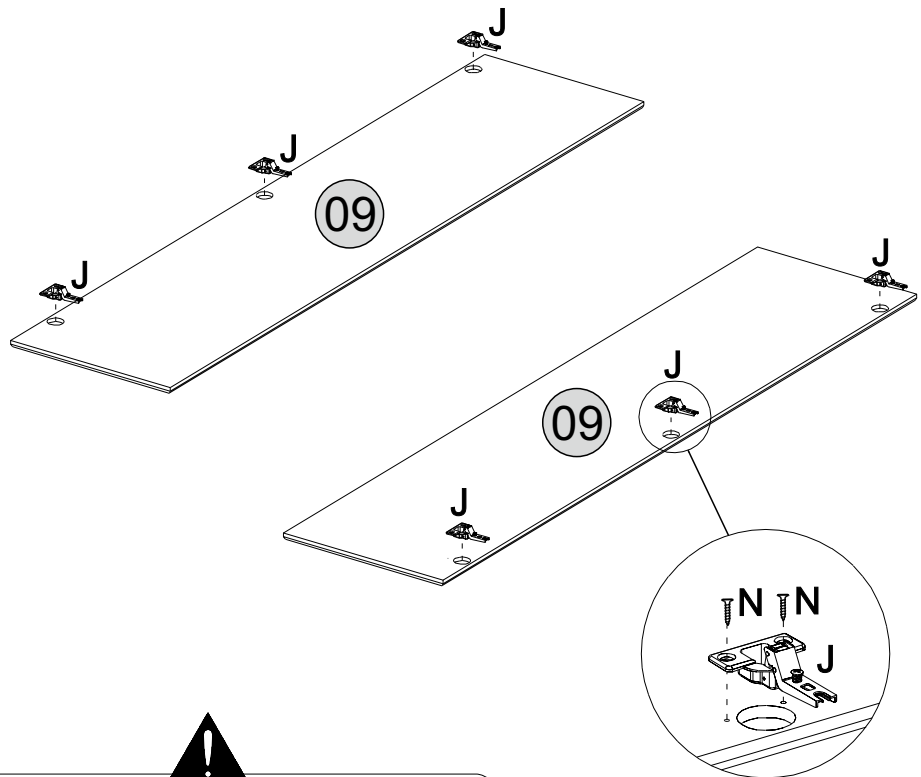
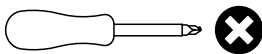

When fitting the door hinge (J) carefully line up the screw holes with those pre-drilled on the door, this will ensure the doors hang correctly.

# STEP 15

## PARTS REQUIRED

09-DOOR x2

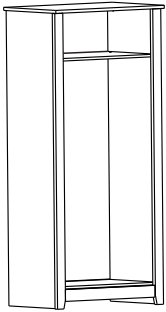

## HARDWARE REQUIRED

H  06  
Ø3,0 x 10 Black

I  02

## TOOLS REQUIRED

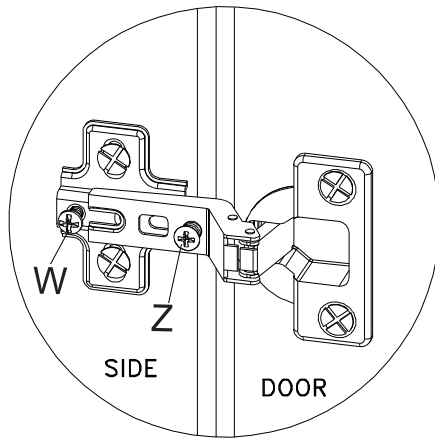
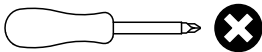

**!**  
SHOULD THE DOORS OF YOUR WARDROBE NOT APPEAR EVEN WHEN CLOSED THEY MAY NEED ADJUSTING. THIS CAN BE DONE AS FOLLOWS: LOOSEN SCREW (W) A LITTLE. BY TURNING SCREW (Z) EITHER CLOCKWISE OR ANTICLOCKWISE (IN OR OUT) THE HINGE CAN BE ADJUSTED AND THE DOOR CORRECTLY ALIGNED. IF MORE THAN ONE HINGE NEEDS ATTENTION PLEASE ADJUST ONE AT A TIME. IF IN DOUBT PLEASE SEEK PROFESSIONAL HELP.

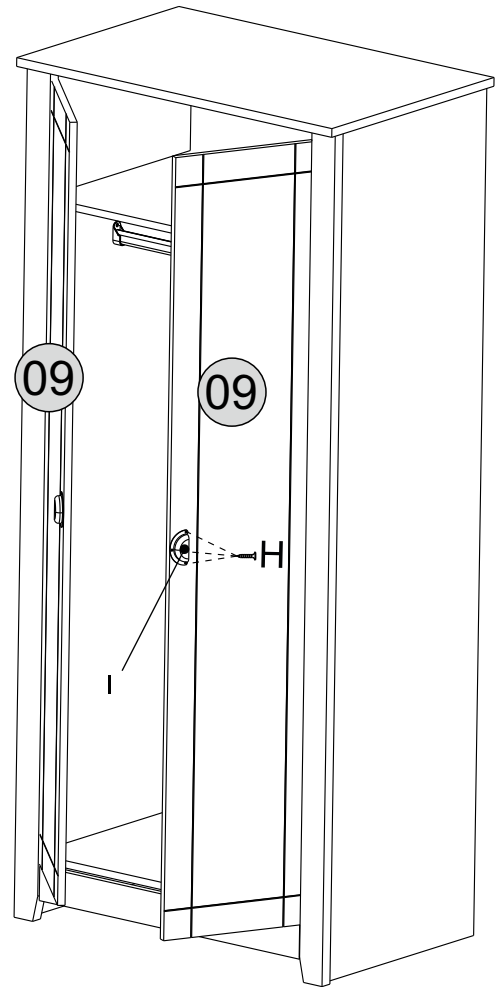

# STEP 16

## PARTS REQUIRED

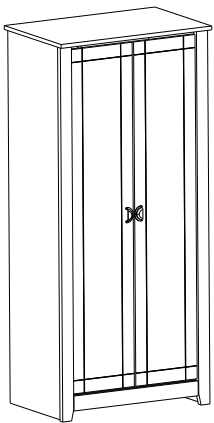

## HARDWARE REQUIRED

P  01

## TOOLS REQUIRED

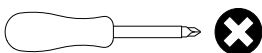

## WARNING

**Serious or fatal injuries can occur from furniture tipping over. To prevent the furniture from tipping over we recommend that it is permanently fixed to the wall.**

Wall fixings are not supplied with this product as different wall materials require different types of fixing devices. Please make sure you use fixings suitable for the walls in your home.

