

NORDIC 2+2 DRAWER CHEST ASSEMBLY INSTRUCTIONS



FOR DOMESTIC USE ONLY IMPORTANT

PLEASE READ BEFORE YOU CONTINUE FURTHER

THE PRODUCT YOU HAVE PURCHASED WILL GIVE YOU MANY YEARS OF SERVICE IF YOU FOLLOW THE GUIDELINES FOR ITS SAFE ASSEMBLY AND PERIODIC MAINTENANCE AND CLEANING.

ASSEMBLE ON A SOFT CLEAN SURFACE.

DO NOT USE ANY TOOLS OTHER THAN THOSE SHOWN.

ANY SPANNERS OR ALLEN KEYS REQUIRED ARE INCLUDED WITH THE FITTING KIT.

DO NOT FOR ANY REASON USE A POWER TOOL TO ASSEMBLE THIS PRODUCT. ITS USE WILL INVALIDATE ANY CLAIM YOU MAY HAVE AND COULD MAKE THIS PRODUCT UNSAFE.

DEPENDING ON THE AMOUNT OF USE THIS PRODUCT RECEIVES, IT MAY BE NECESSARY TO TIGHTEN UP THE FIXINGS FROM TIME TO TIME. THIS IS COMPLETELY NORMAL FOR ANY FLAT PACK FURNITURE. DO NOT OVERTIGHTEN FIXINGS.

FOR CLEANING, YOU MAY USE A DAMP CLOTH (NOT WET). DO NOT USE POLISH, DETERGENT OR CHEMICAL CLEANERS.



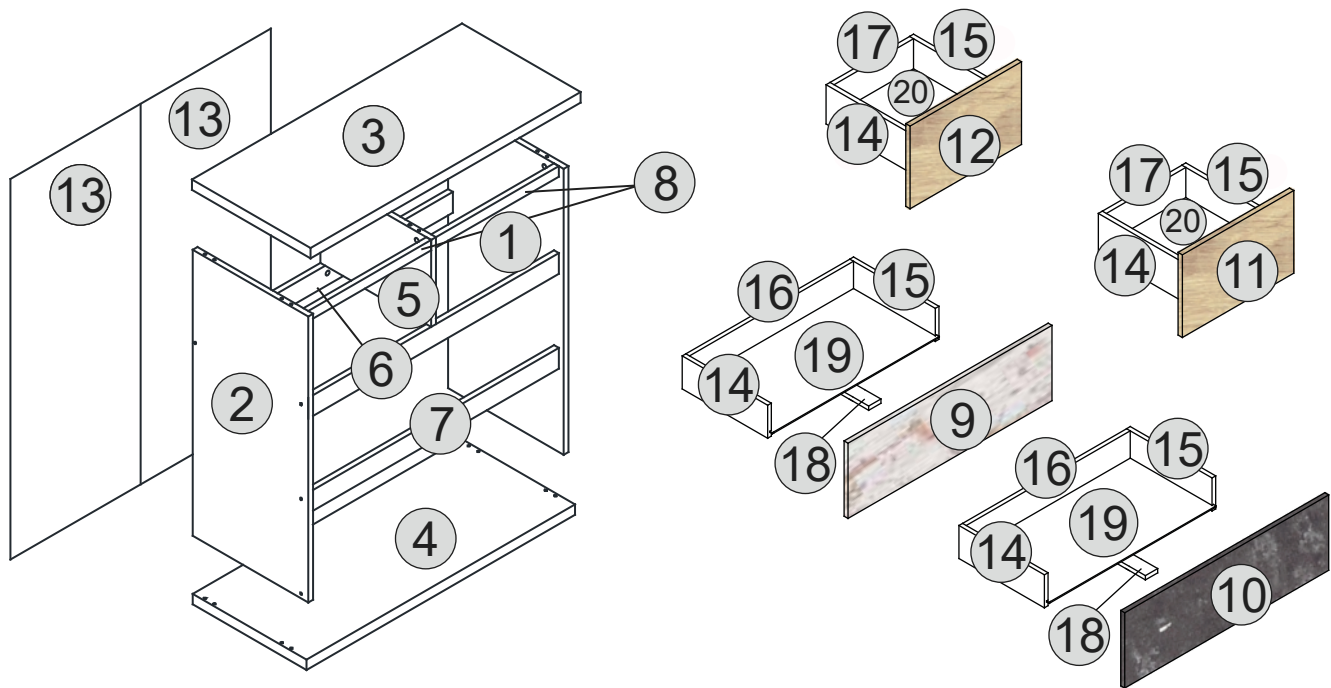











THIS SURFACE OF THIS ITEM IS NOT HEAT RESISTANT. ALWAYS USE A PLACE MAT UNDER HOT OR COLD ITEMS TO PREVENT MARKING.



PART LIST

Part Number	Part Code	Part Description	Quantity	Carton
1	S100-102-096-ZF1-01	Right Side Panel	1	1/1
2	S100-102-096-ZF1-02	Left Side Panel	1	1/1
3	S100-102-096-ZF1-03	Top Panel	1	1/1
4	S100-102-096-ZF1-04	Bottom Panel	1	1/1
5	S100-102-096-ZF1-05	Shelf Panel	1	1/1
6	S100-102-096-ZF1-06	Horizontal Support Panel	2	1/1
7	S100-102-096-ZF1-07	Horizontal Support Panel	1	1/1
8	S100-102-096-ZF1-08	Top Support Panel	2	1/1
9	S100-102-096-ZF1-09	Large Drawer Front	1	1/1
10	S100-102-096-ZF1-10	Large Drawer Front	1	1/1
11	S100-102-096-ZF1-11	Right Small Drawer Front	1	1/1
12	S100-102-096-ZF1-12	Left Small Drawer Front	1	1/1
13	S100-102-096-ZF1-13	Back Panel	2	1/1
14	S100-102-096-ZF1-14	Left Drawer Side	4	1/1
15	S100-102-096-ZF1-15	Right Drawer Side	4	1/1
16	S100-102-096-ZF1-16	Large Drawer Back	2	1/1
17	S100-102-096-ZF1-17	Small Drawer Back	2	1/1
18	S100-102-096-ZF1-18	Drawer Support	2	1/1
19	S100-102-096-ZF1-19	Large Drawer Base	2	1/1
20	S100-102-096-ZF1-20	Small Drawer Base	2	1/1

HARDWARE LIST

No.	Part Name		Qty	Carton
A	Wooden Dowel (6x25mm)		x36	1
B	45mm Screw (4x45mm)		x10	1
C	14mm Screw (3.5x14mm)		x58	1
D	38mm Screw (4x38mm)		x18	1
E	Cam Bolt (8032T)		x18	1
F	Cam Nut (1512)		x18	1
G	Wood Leg + Plastic Foot		x4	1
H	6/8" Nail		x35	1
I	14" Drawer Slide		x4	1
J	PVC L-Bracket		x2	1
K	Handle+Screw (L-3510 3x16mm=8pcs)		x2	1
L	Screw Cover (CB-White)		x6	1
M	Handle+Screw (T-4538 4x20mm=2pcs)		x1	1
N	Handle+Screw (Y-8238 3x16mm=2pcs)		x1	1
O	Wall Fixings (4x20mm=1pc)		x1	1

TIPS FOR FITTINGS CAM-LOCKS

WHEN FITTING CAM NUT. ENSURE STARTING POSITION IS CORRECT BEFORE YOU INSERT. CONNECTING CAM BOLT TURN CLOCKWISE UNTIL SECURE

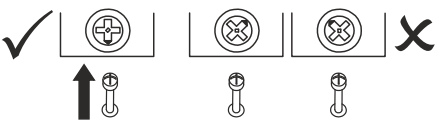

CORRECT **WRONG**

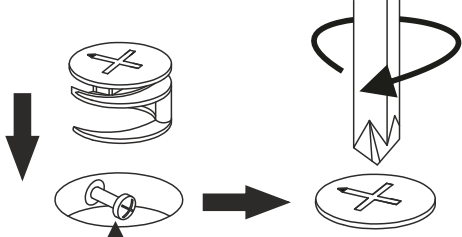

Cam bolt head needs to be in centre

CAMBOLT

Tighten until shoulder in flush with panel. Do not overtighten or undertighten (see example below)

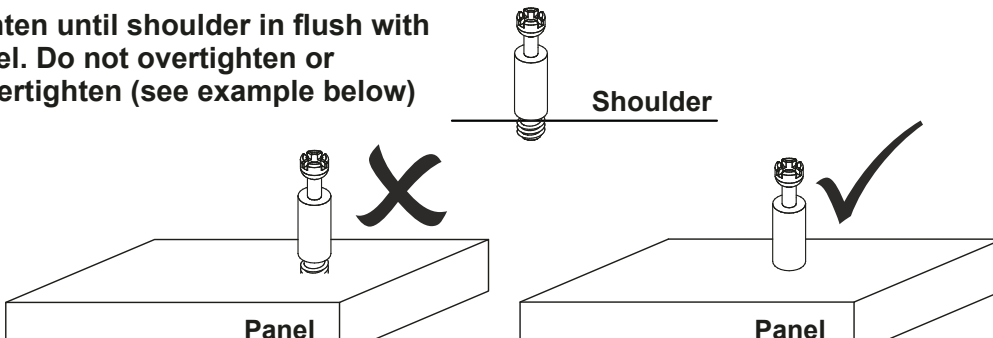

Shoulder

Panel **Panel**

STEP 1

PARTS REQUIRED

2 - LEFT SIDE PANEL x1

HARDWARE REQUIRED

A  04

C  3.5x14mm 06

F  02

I  03

TOOLS REQUIRED

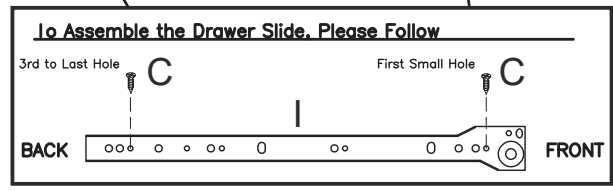
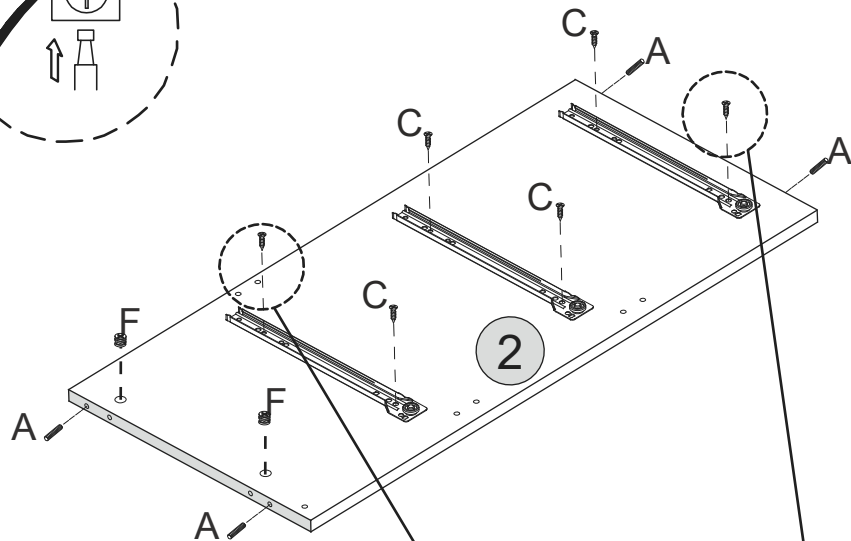
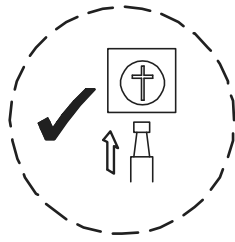
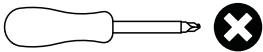



STEP 2

PARTS REQUIRED

1 - RIGHT SIDE PANEL x1

HARDWARE REQUIRED

A  04

C  3.5x14mm 06

F  02

I  03

TOOLS REQUIRED

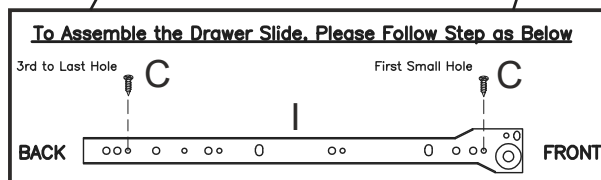
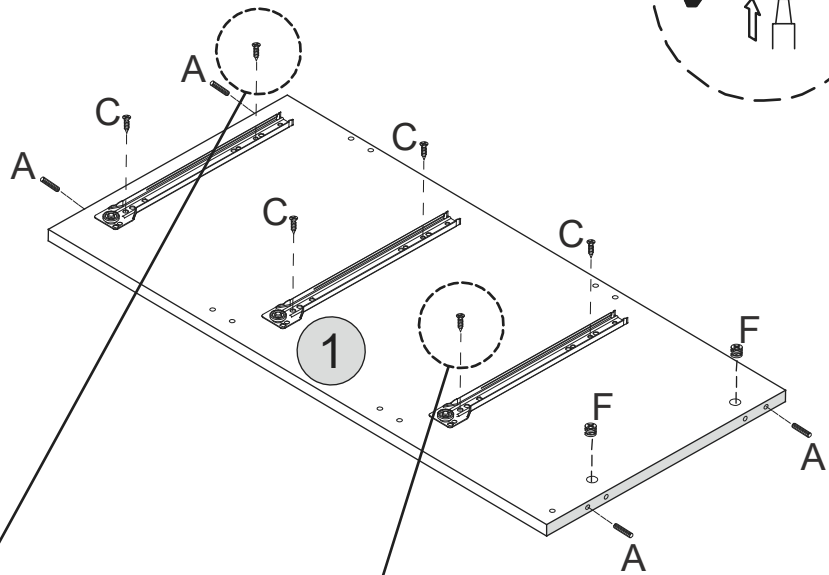
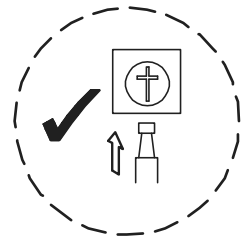
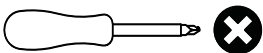



STEP 3

PARTS REQUIRED

5 - SHELF PANEL x1

HARDWARE REQUIRED

C  04
3.5x14mm

E  02

F  02

I  02

TOOLS REQUIRED

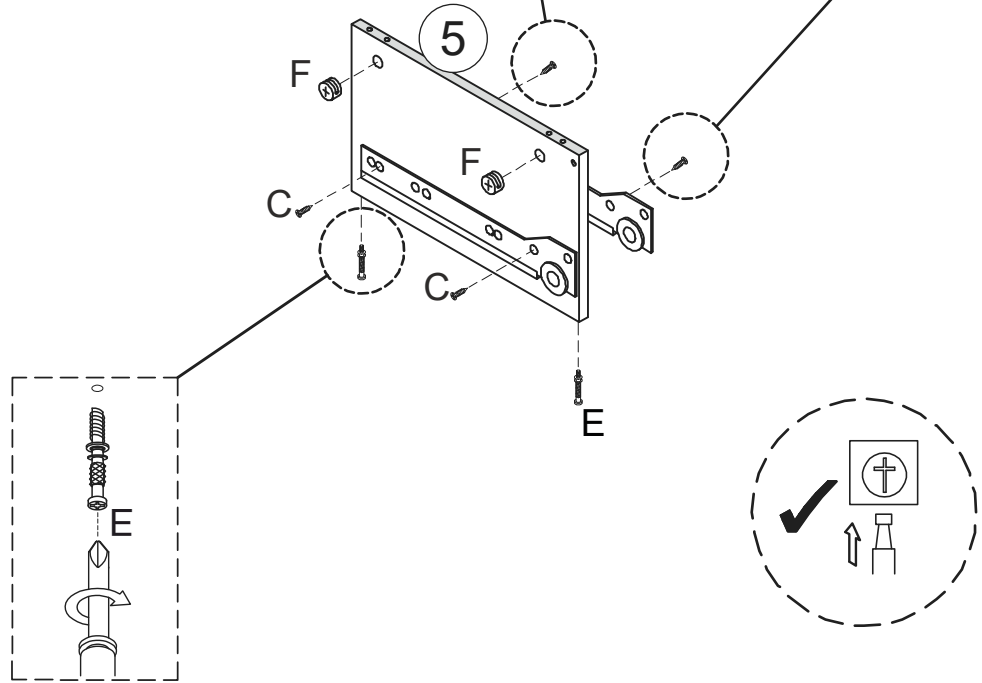
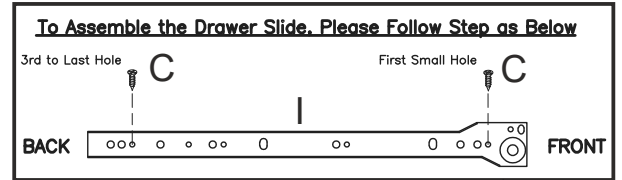
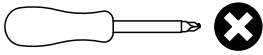

STEP 4

PARTS REQUIRED

6 - HORIZONTAL SUPPORT PANEL x2

7 - HORIZONTAL SUPPORT PANEL x1

8 - TOP SUPPORT PANEL x2

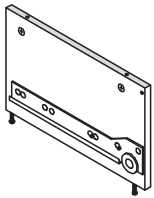

HARDWARE REQUIRED

A  12
6x25mm

F  02

TOOLS REQUIRED

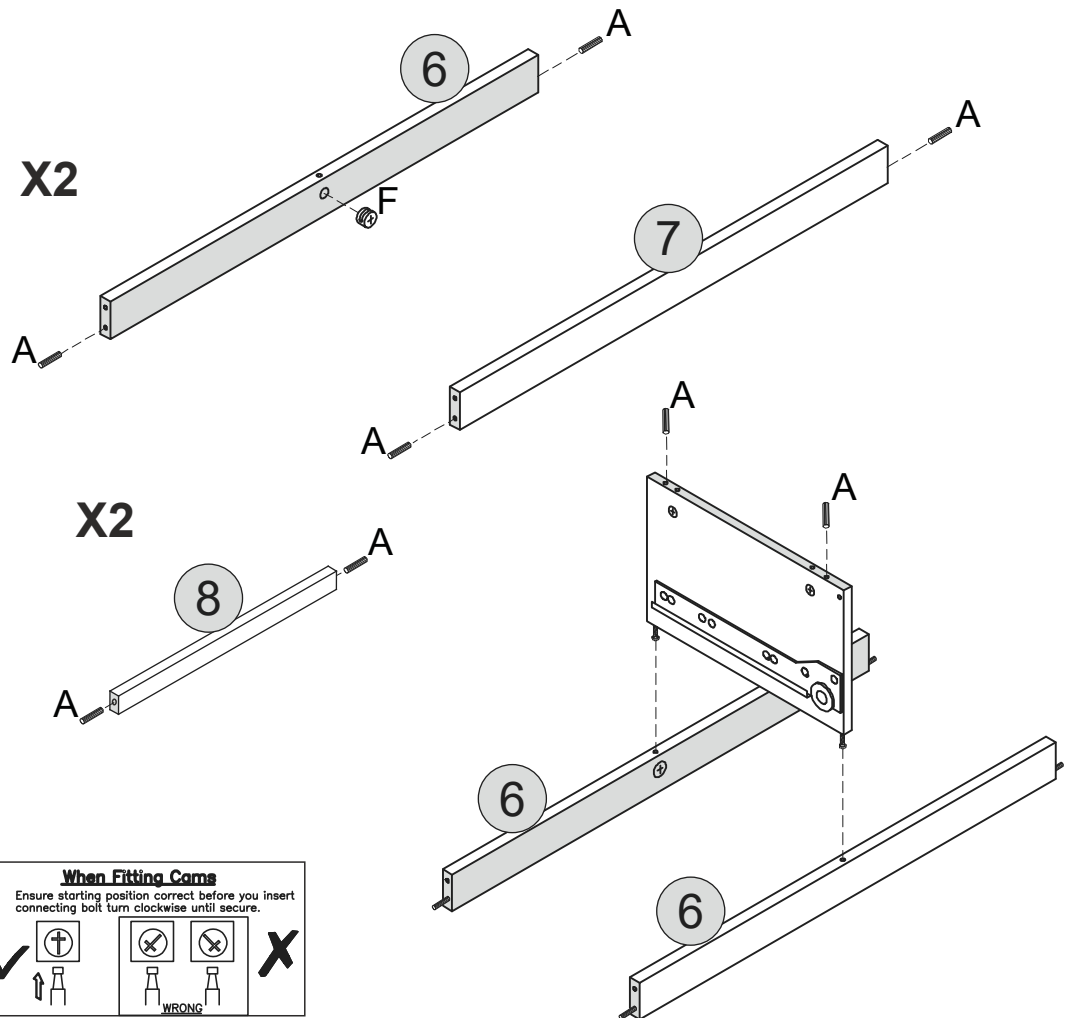
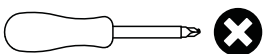

STEP 5

PARTS REQUIRED

3 - TOP PANEL x1

HARDWARE REQUIRED

C  04
3.5x14mm

E  06

J  02

TOOLS REQUIRED

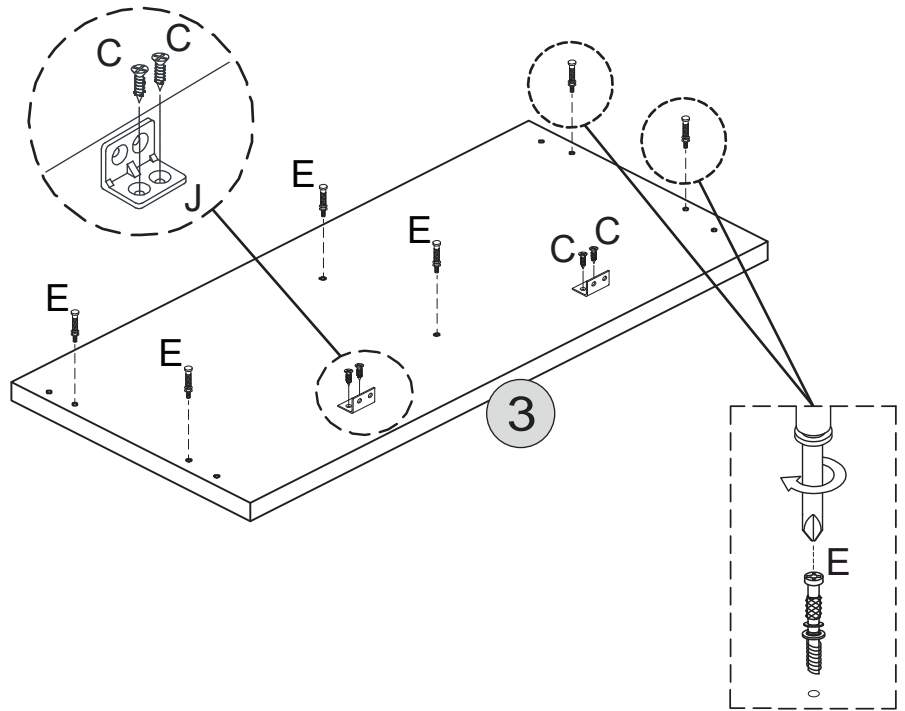
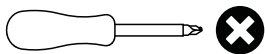

STEP 6

PARTS REQUIRED

2 - LEFT SIDE PANEL x1

8 - TOP SUPPORT PANEL x1

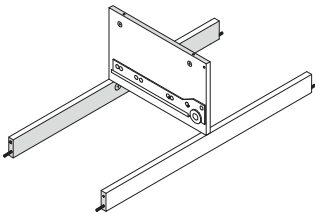

HARDWARE REQUIRED

B  02
4x45mm

TOOLS REQUIRED

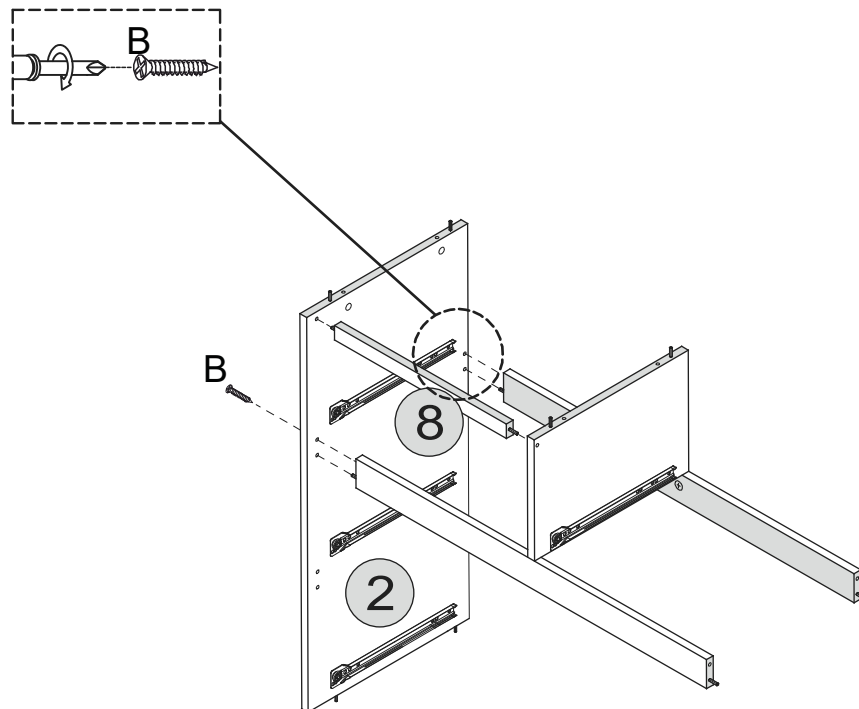
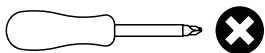

STEP 7

PARTS REQUIRED

1 - RIGHT SIDE PANEL x1

7 - HORIZONTAL SUPPORT PANEL x1

8 - TOP SUPPORT PANEL x1

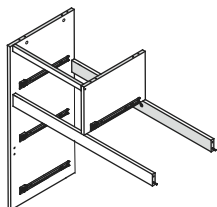

HARDWARE REQUIRED

B  04
4x45mm

TOOLS REQUIRED

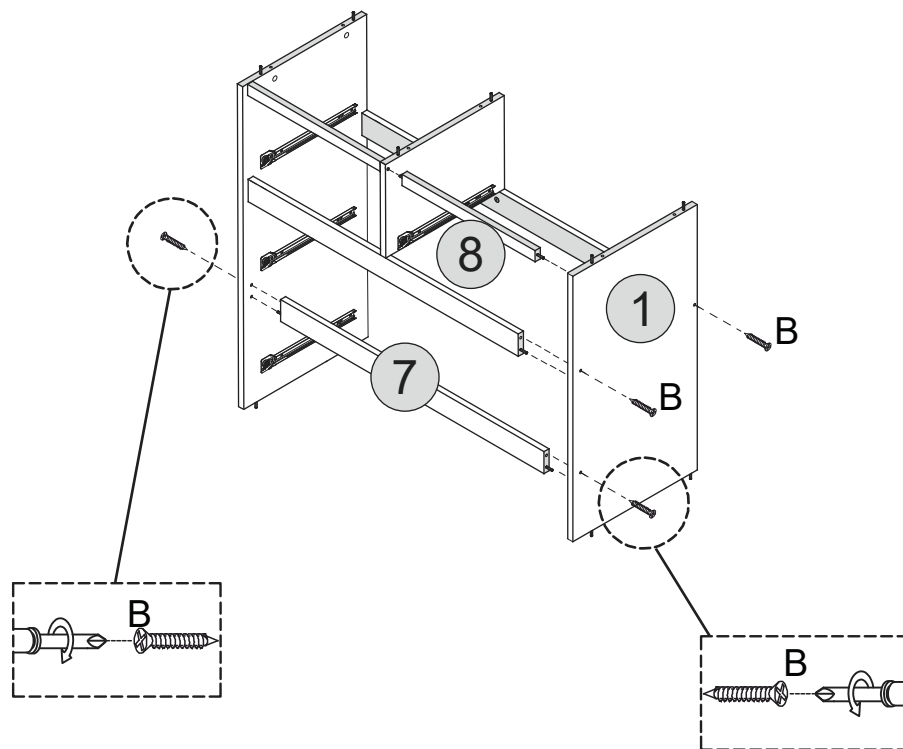
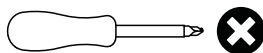

STEP 8

PARTS REQUIRED

3 - TOP PANEL x1

4 - BOTTOM PANEL x1

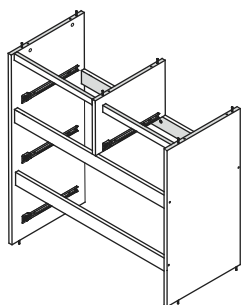

HARDWARE REQUIRED

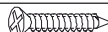
B  04
4x45mm

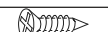
C  04
3.5x14mm

TOOLS REQUIRED

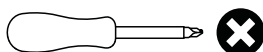

When Fitting Cams
Ensure starting position correct before you insert connecting bolt turn clockwise until secure.

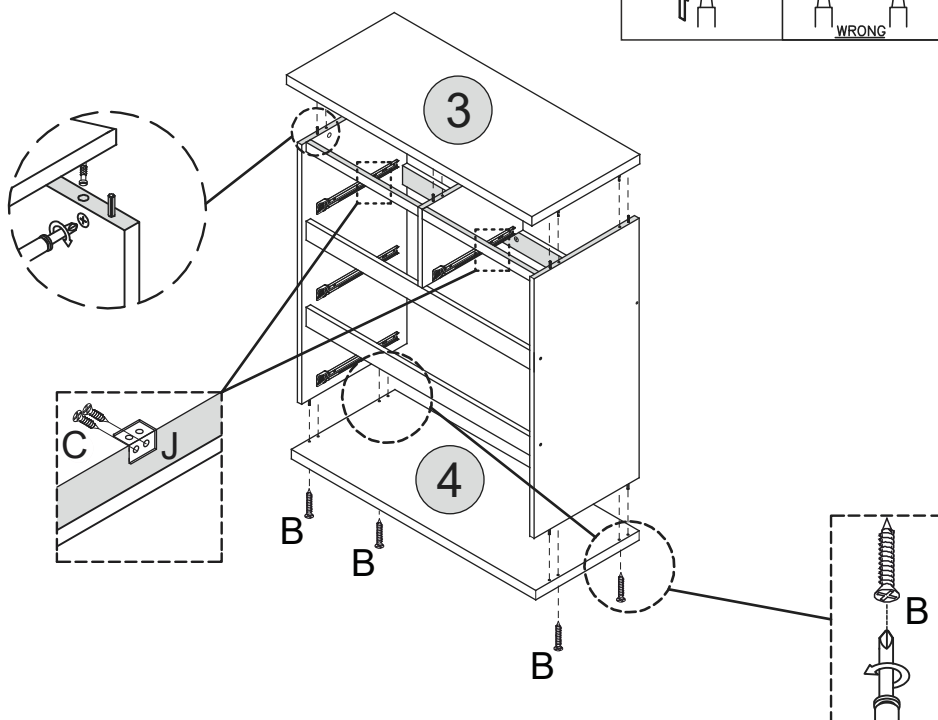

STEP 9

PARTS REQUIRED

13 - BACK PANEL x2

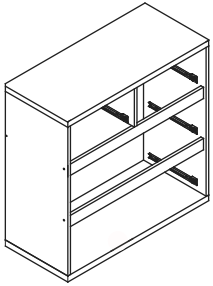

HARDWARE REQUIRED

C  18
3.5x14mm

G  04

H  35

TOOLS REQUIRED

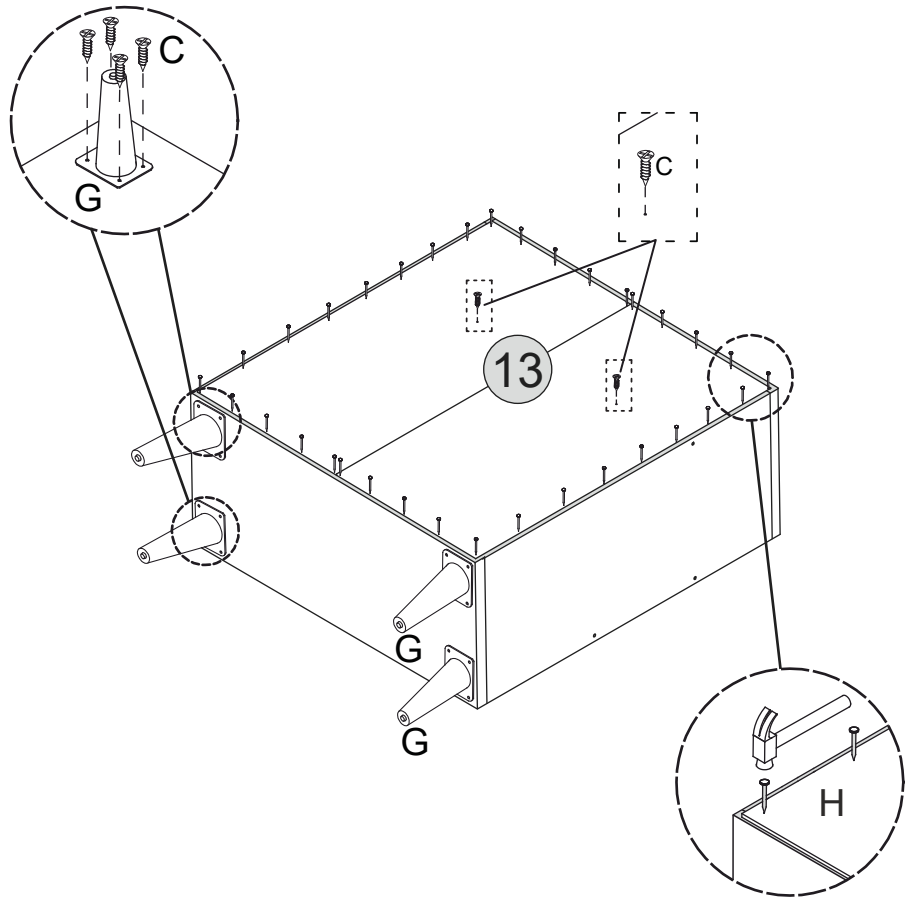
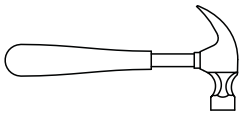
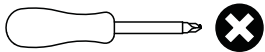

STEP 10

PARTS REQUIRED

10 -DRAWER FRONT LARGE x1

14 -LEFT DRAWER SIDE x1

15 -RIGHT DRAWER SIDE x1

18 -DRAWER SUPPORT x1

HARDWARE REQUIRED

A  04

E  03

F  03

TOOLS REQUIRED

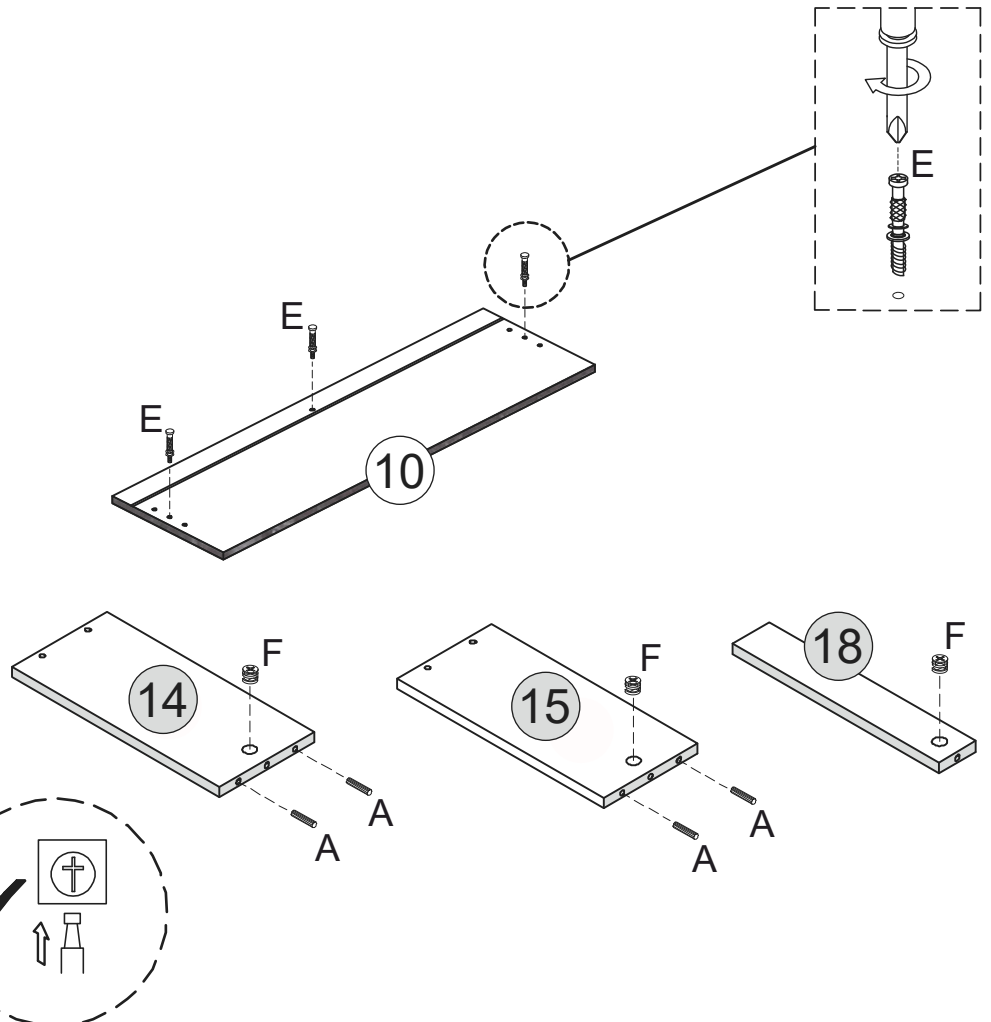
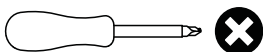

STEP 11

PARTS REQUIRED

- 10 - DRAWER FRONT LARGE x1
- 14 - LEFT DRAWER SIDE x1
- 15 - RIGHT DRAWER SIDE x1
- 16 - LARGE DRAWER BACK x1
- 18 - DRAWER SUPPORT x1
- 19 - LARGE DRAWER BASE x1

HARDWARE REQUIRED

- D  05
4x38mm

TOOLS REQUIRED

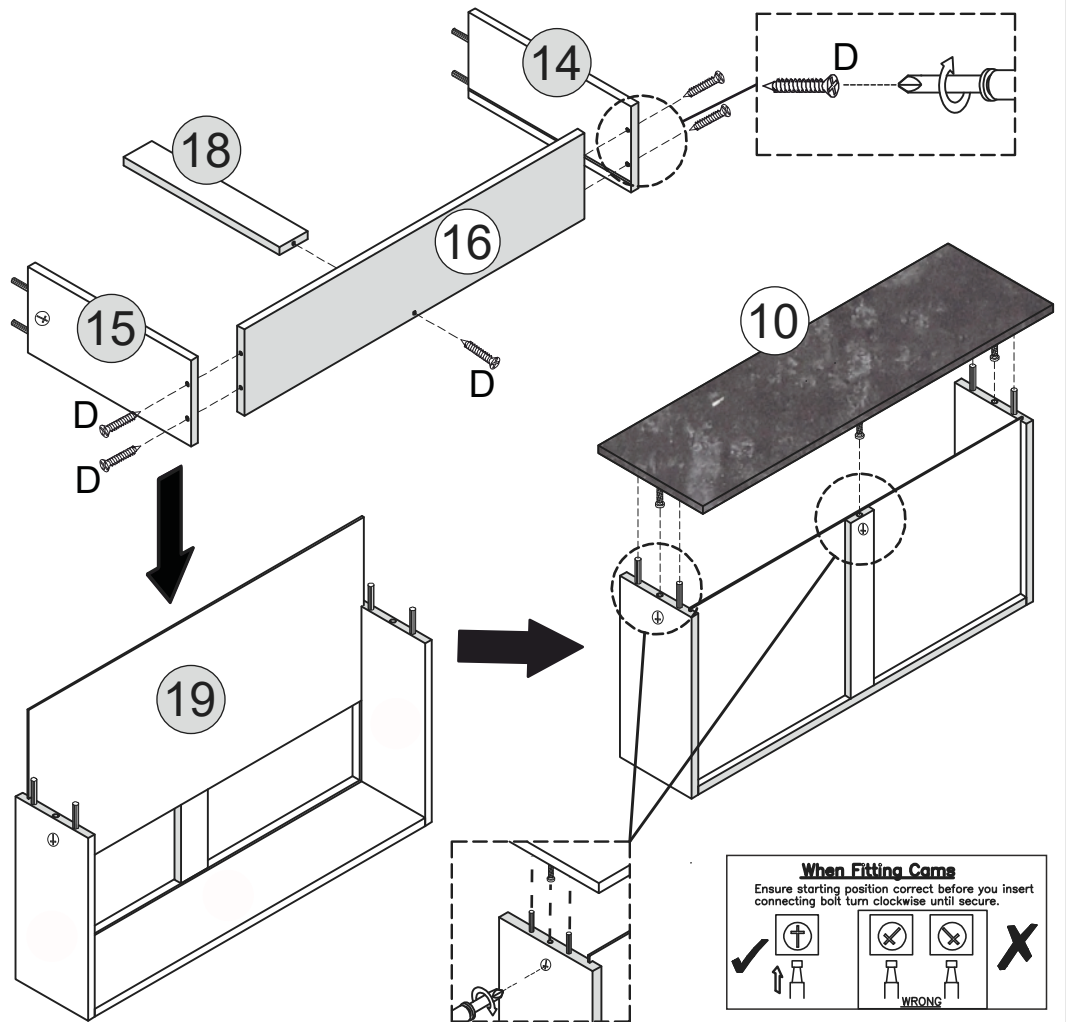
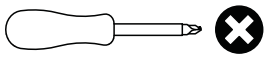

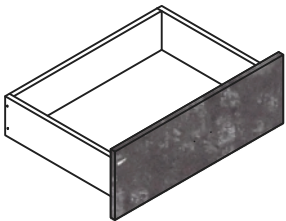

STEP 12

PARTS REQUIRED



HARDWARE REQUIRED

- C  04
3.5x16mm
- I  01
- N  01

TOOLS REQUIRED

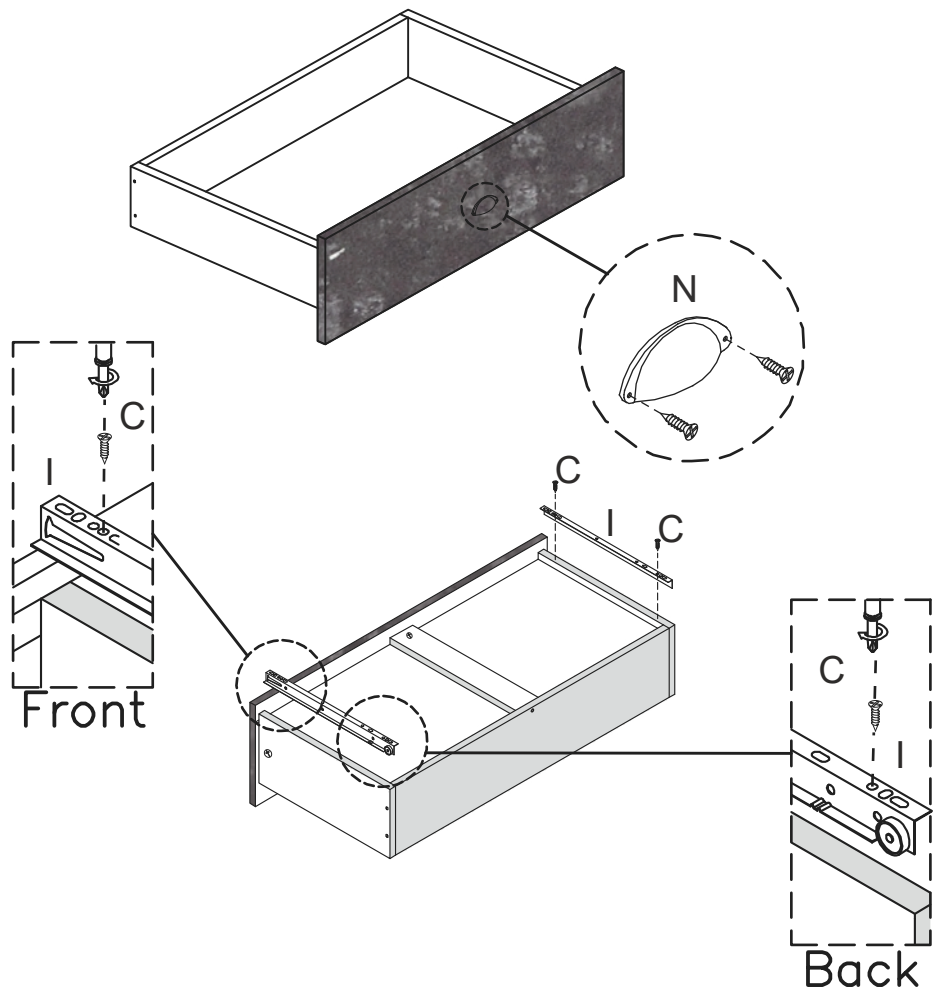
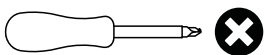



STEP 13

PARTS REQUIRED

- 9 - DRAWER FRONT LARGE x1
- 14 -LEFT DRAWER SIDE x1
- 15 -RIGHT DRAWER SIDE x1
- 18 -DRAWER SUPPORT x1

HARDWARE REQUIRED

- A  04
- E  03
- F  03

TOOLS REQUIRED

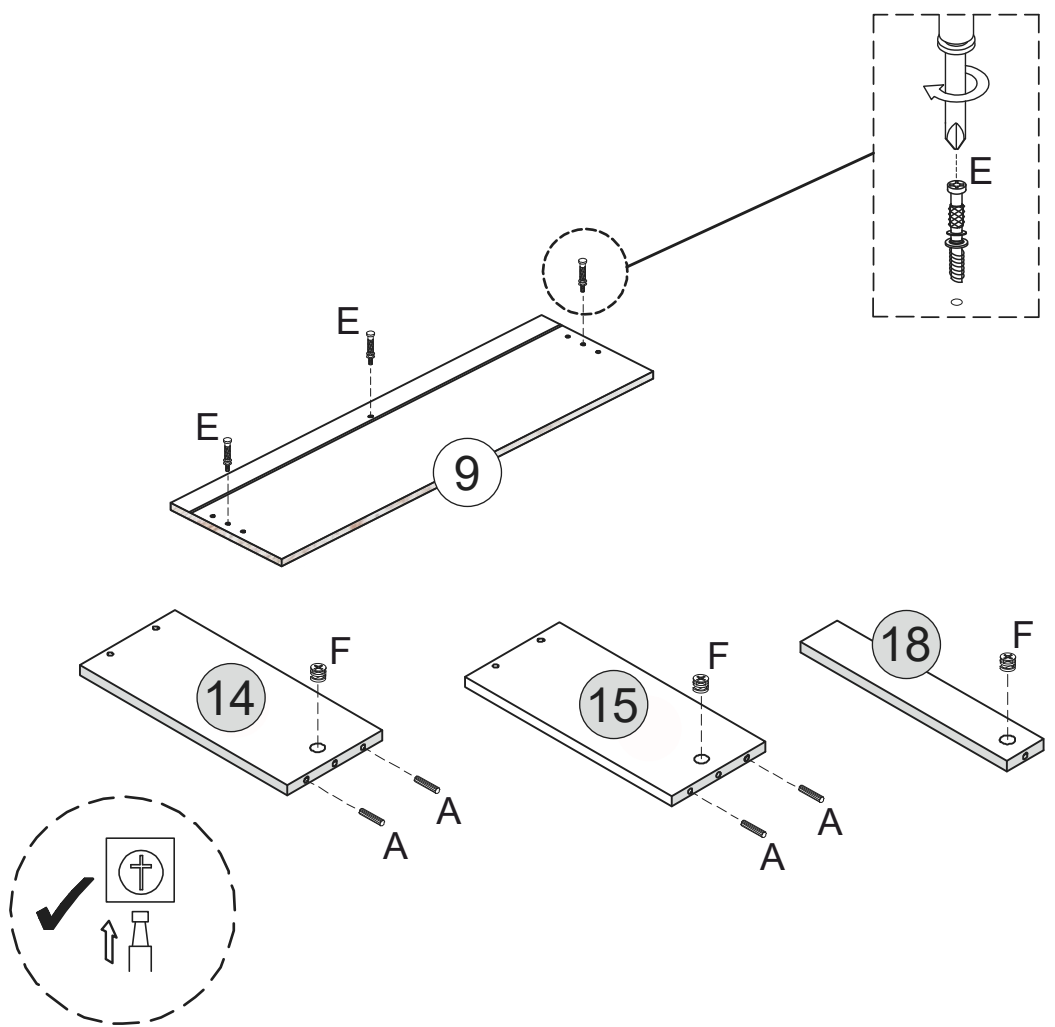
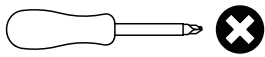

STEP 14

PARTS REQUIRED

- 9 - DRAWER FRONT LARGE x1
- 14 -LEFT DRAWER SIDE x1
- 15 -RIGHT DRAWER SIDE x1
- 16 -DRAWER BACK LARGE x1
- 18 -DRAWER SUPPORT x1
- 19 -LARGE DRAWER BASE x1

HARDWARE REQUIRED

- D  4x38mm 05

TOOLS REQUIRED

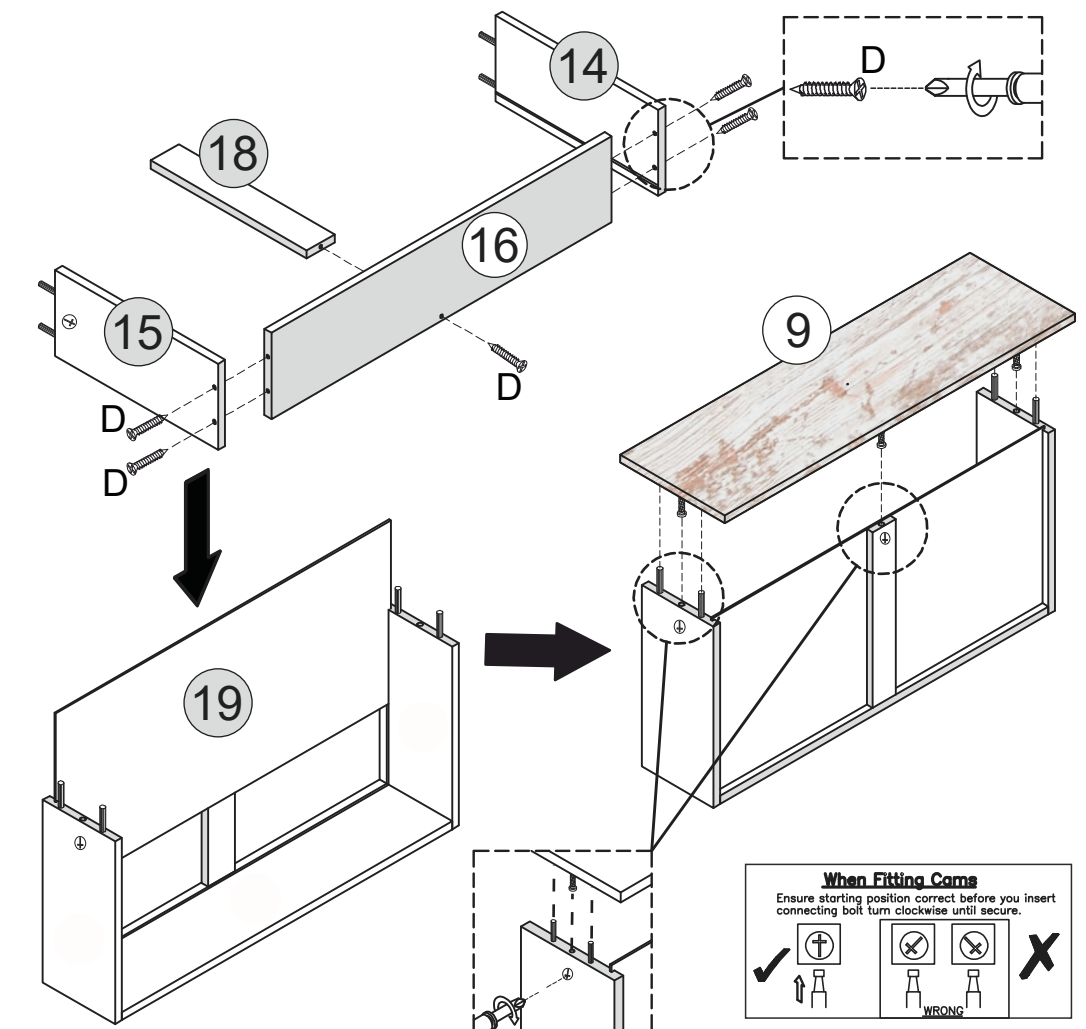
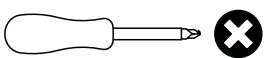

STEP 15

PARTS REQUIRED

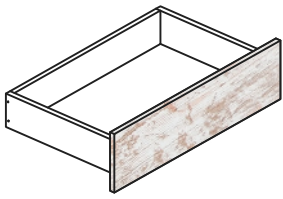

HARDWARE REQUIRED

C	3.5x16mm	04
I		01
M		01

TOOLS REQUIRED

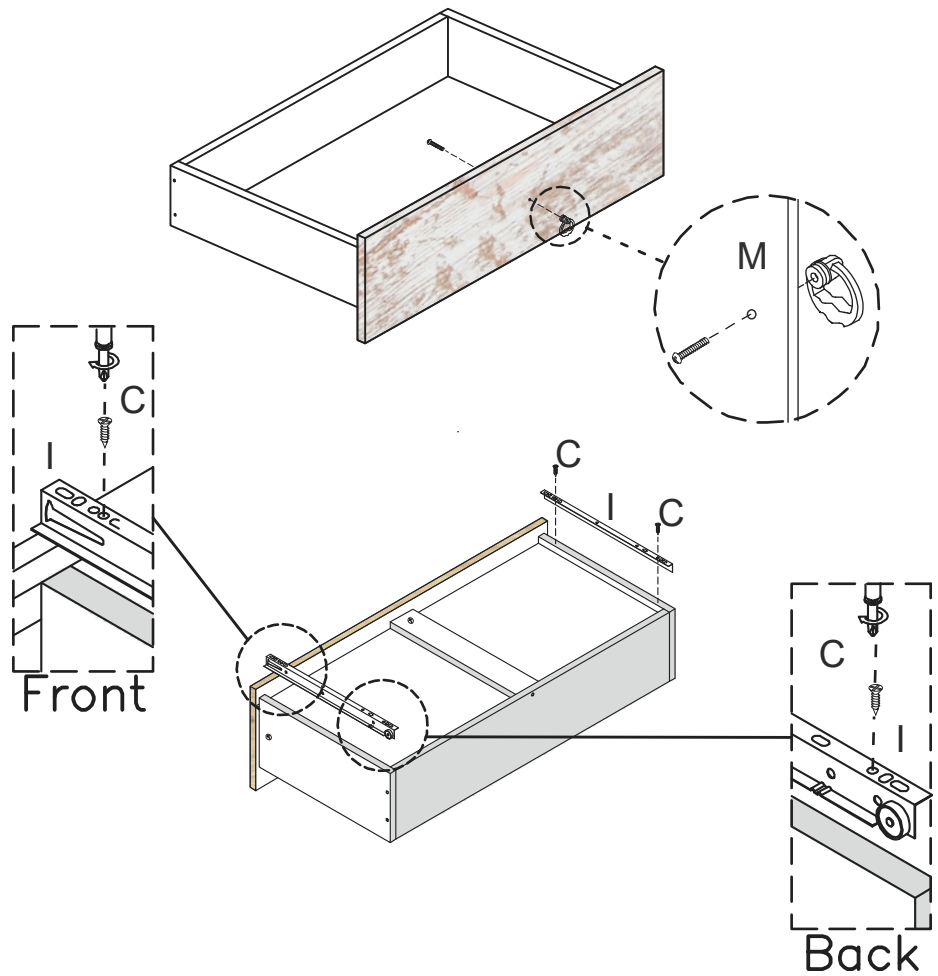
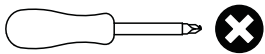

STEP 16

PARTS REQUIRED

12	-LEFT SMALL DRAWER FRONT	x1
14	-LEFT DRAWER SIDE	x1
15	-RIGHT DRAWER SIDE	x1

HARDWARE REQUIRED

A		04
E		02
F		02

TOOLS REQUIRED

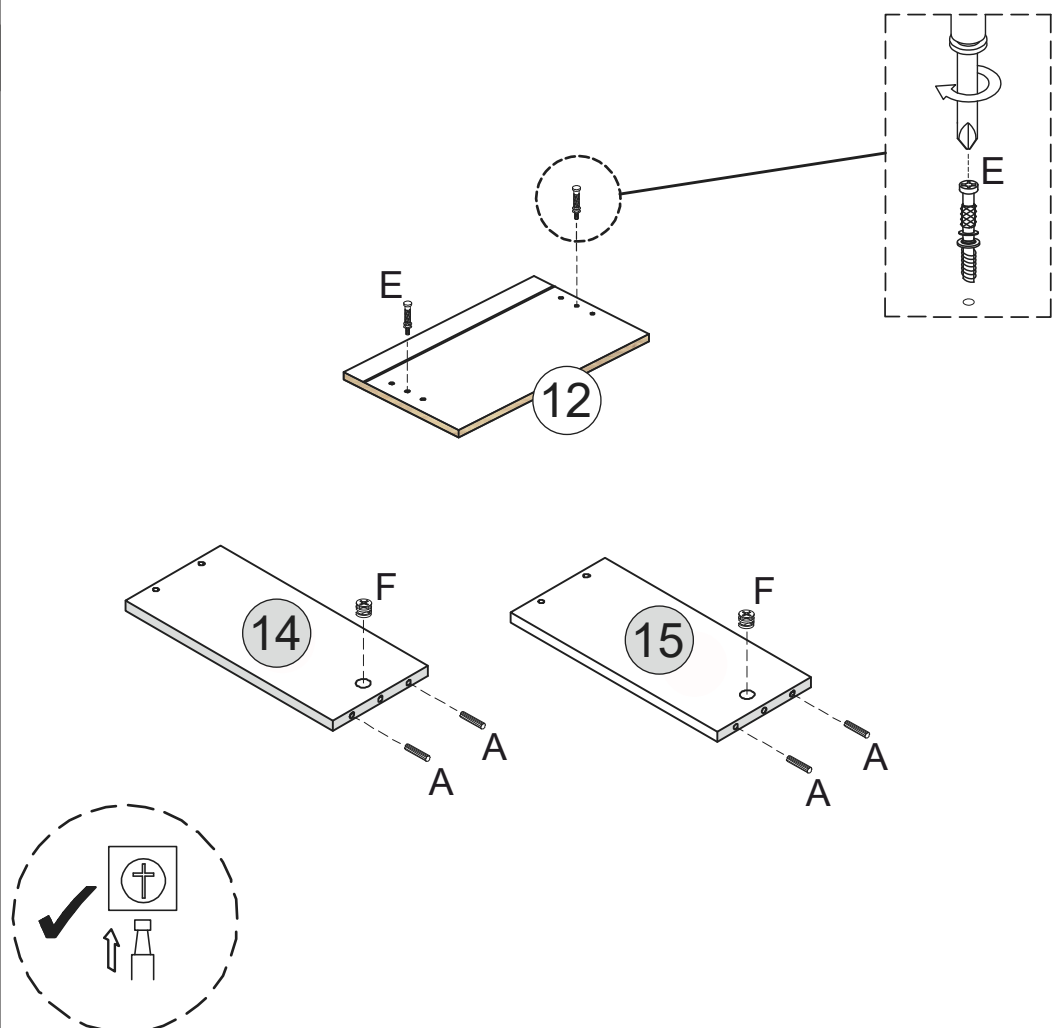
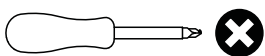

STEP 17

PARTS REQUIRED

12 - LEFT SMALL DRAWER FRONT x1

14 - LEFT DRAWER SIDE x1

15 - RIGHT DRAWER SIDE x1

17 - SMALL DRAWER BACK x1

20 - SMALL DRAWER BASE x1

HARDWARE REQUIRED

D  04
4x38mm

TOOLS REQUIRED

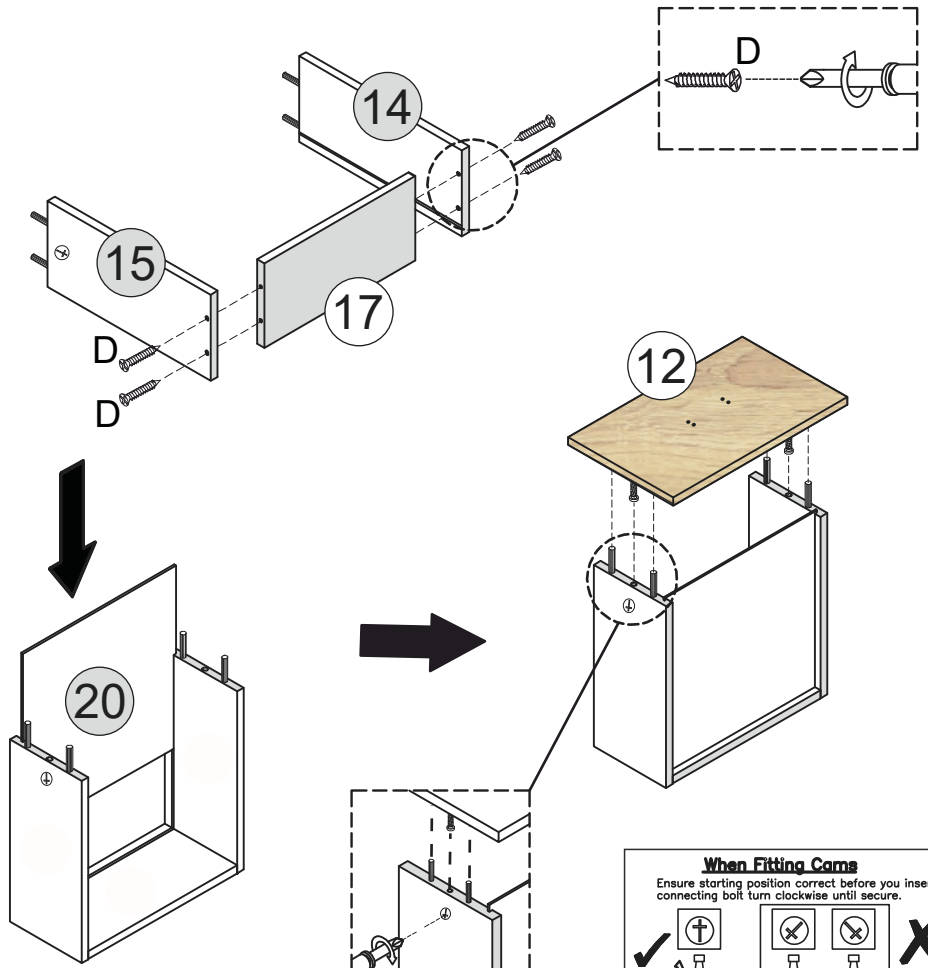
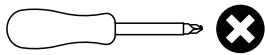

STEP 18

PARTS REQUIRED

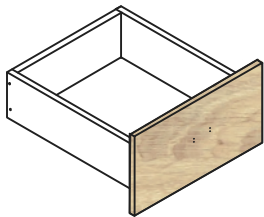

HARDWARE REQUIRED

C  04
3.5x16mm

I  01

K  01

TOOLS REQUIRED

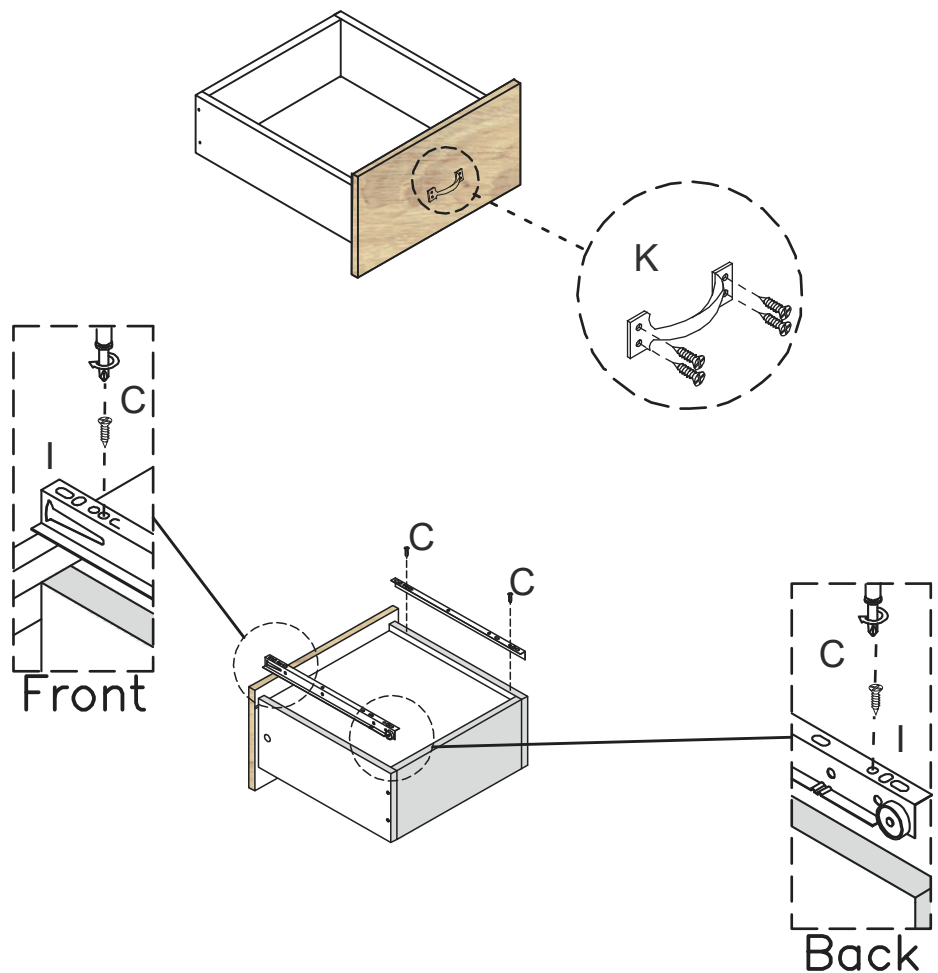
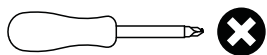

STEP 19

PARTS REQUIRED

11 - RIGHT SMALL DRAWER FRONT x1

14 - LEFT DRAWER SIDE x1

15 - RIGHT DRAWER SIDE x1

HARDWARE REQUIRED

A  04

E  02

F  02

TOOLS REQUIRED

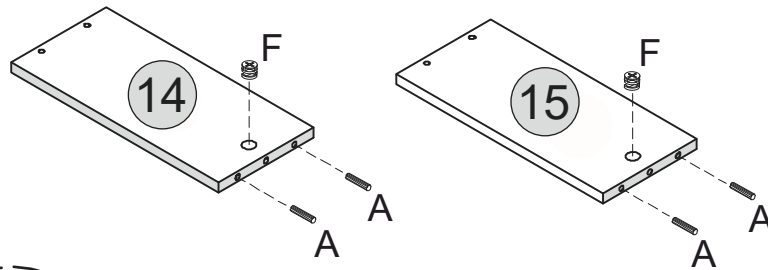
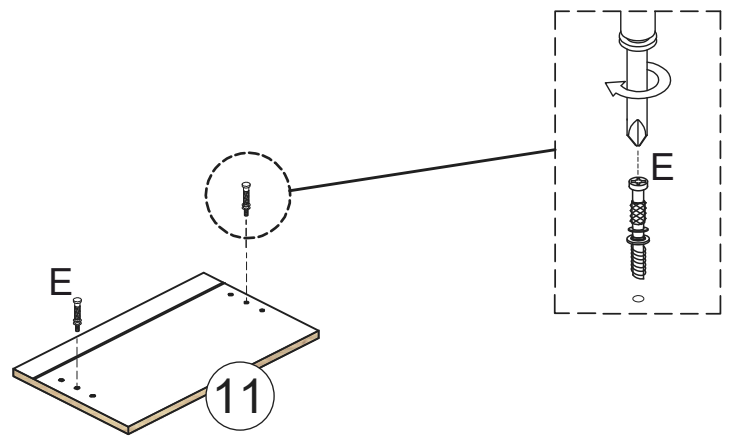
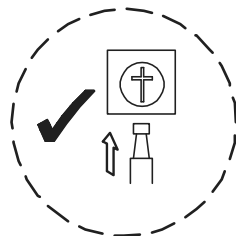
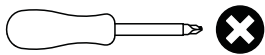

STEP 20

PARTS REQUIRED

11 - RIGHT SMALL DRAWER FRONT x1

14 - LEFT DRAWER SIDE x1

15 - RIGHT DRAWER SIDE x1

17 - SMALL DRAWER BACK x1

20 - SMALL DRAWER BASE x1

HARDWARE REQUIRED

D  04
4x38mm

TOOLS REQUIRED

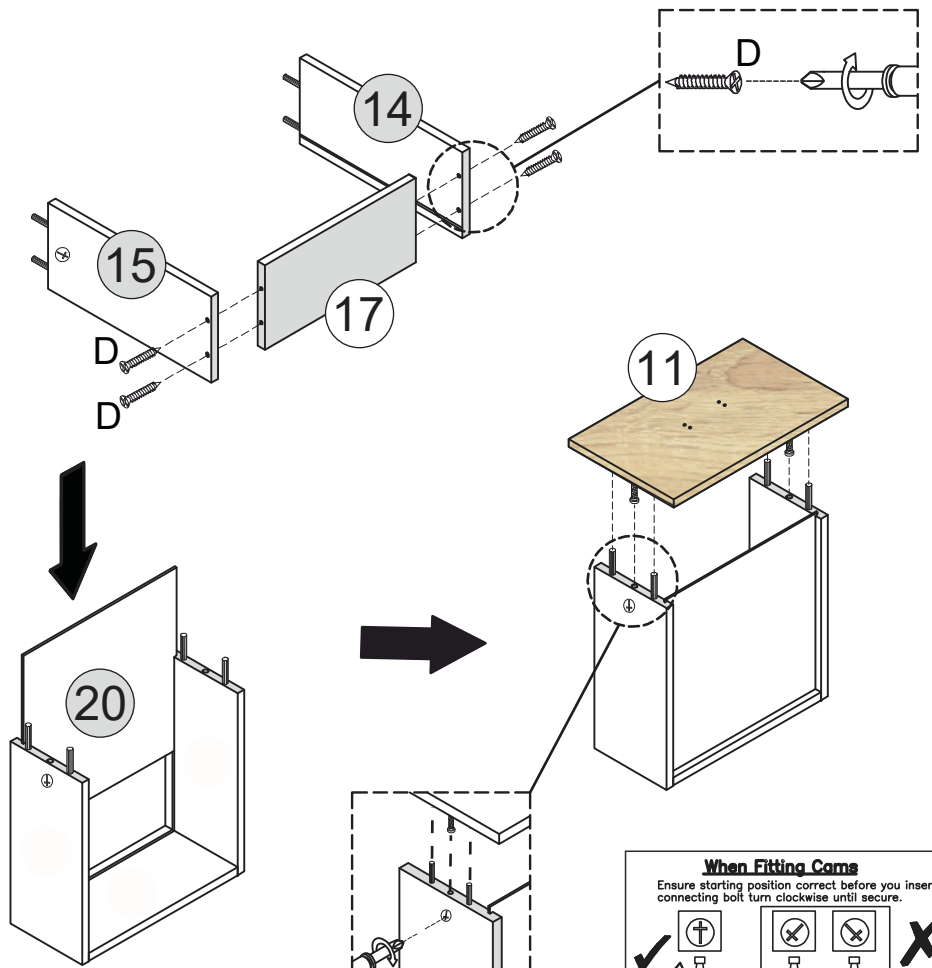
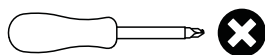

When Fitting Cams
Ensure starting position correct before you insert connecting bolt turn clockwise until secure.

STEP 21

PARTS REQUIRED

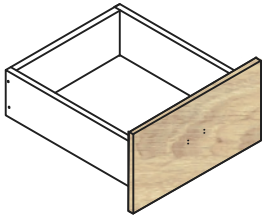

HARDWARE REQUIRED

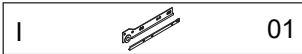

TOOLS REQUIRED

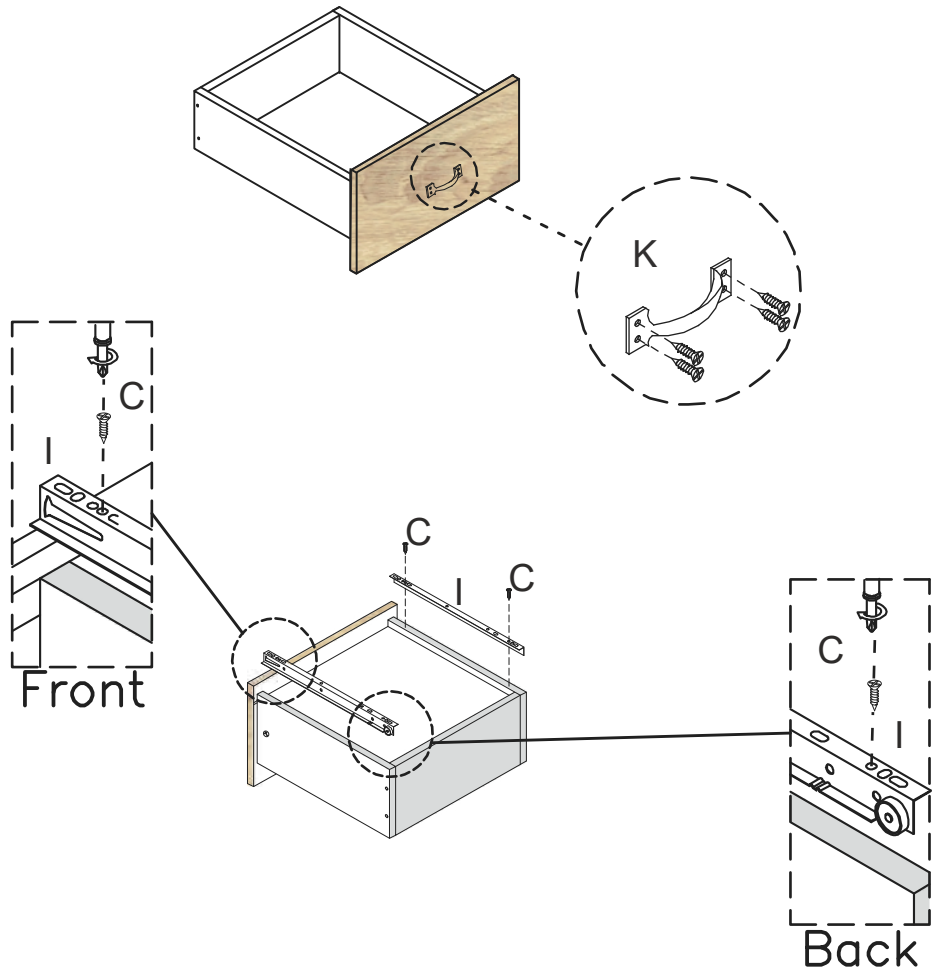
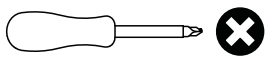

STEP 22

PARTS REQUIRED

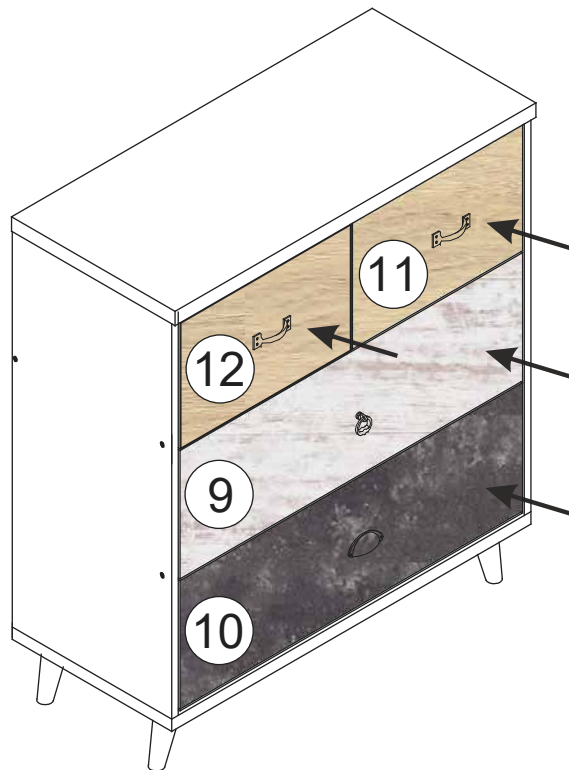
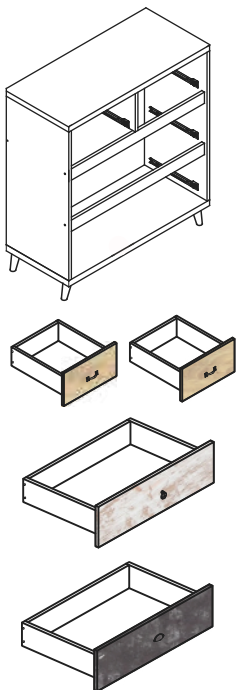

STEP 23

PARTS REQUIRED



HARDWARE REQUIRED

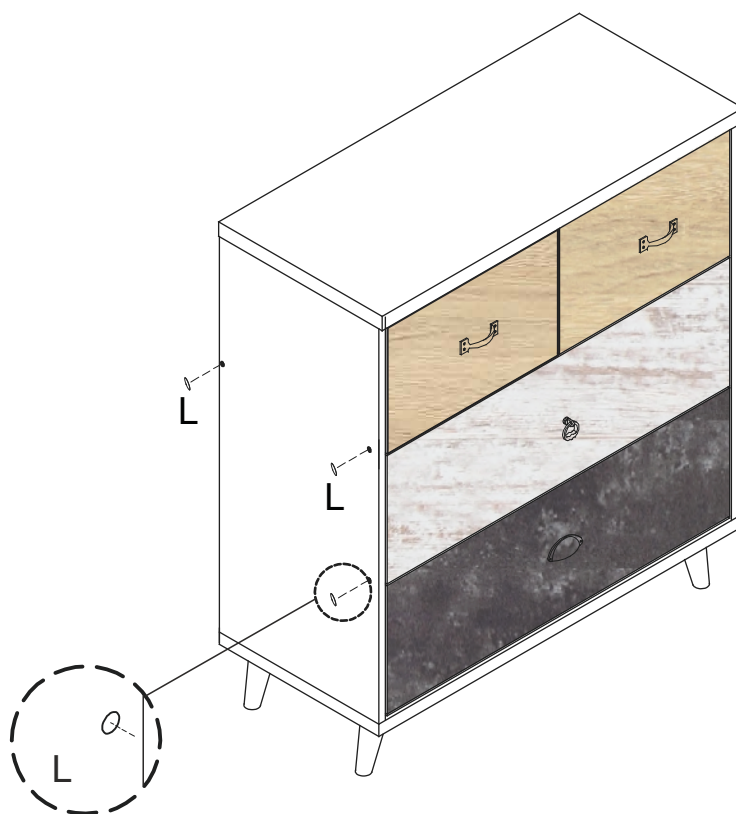

STEP 24



HARDWARE REQUIRED



TOOLS REQUIRED

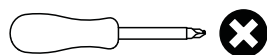

WARNING

Serious or fatal injuries can occur from furniture tipping over. To prevent the furniture from tipping over we recommend that it is permanently fixed to the wall.

Wall fixings are not supplied with this product as different wall materials require different types of fixing devices. Please make sure you use fixings suitable for the walls in your home.

