

FELIX 2 DRAWER BEDSIDE ASSEMBLY INSTRUCTIONS

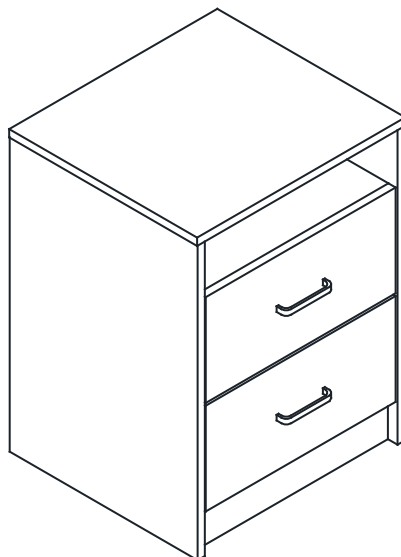

FOR DOMESTIC USE ONLY IMPORTANT

PLEASE READ BEFORE YOU CONTINUE FURTHER

THE PRODUCT YOU HAVE PURCHASED WILL GIVE YOU MANY YEARS OF SERVICE IF YOU FOLLOW THE GUIDELINES FOR ITS SAFE ASSEMBLY AND PERIODIC MAINTENANCE AND CLEANING

ASSEMBLE ON A SOFT CLEAN SURFACE

DO NOT USE ANY TOOLS OTHER THAN THOSE SHOWN

ANY SPANNERS OR ALLEN KEYS REQUIRED ARE INCLUDED WITH THE FITTING KIT.

DO NOT FOR ANY REASON USE A POWER TOOL TO ASSEMBLE THIS PRODUCT. ITS USE WILL INVALIDATE ANY CLAIM YOU MAY HAVE AND COULD MAKE THIS PRODUCT UNSAFE.

DEPENDING ON THE AMOUNT OF USE THIS PRODUCT RECEIVES, IT MAY BE NECESSARY TO TIGHTEN UP THE FIXINGS FROM TIME TO TIME. THIS IS COMPLETELY NORMAL FOR ANY FLAT PACK FURNITURE. DO NOT OVERTIGHTEN FIXINGS.





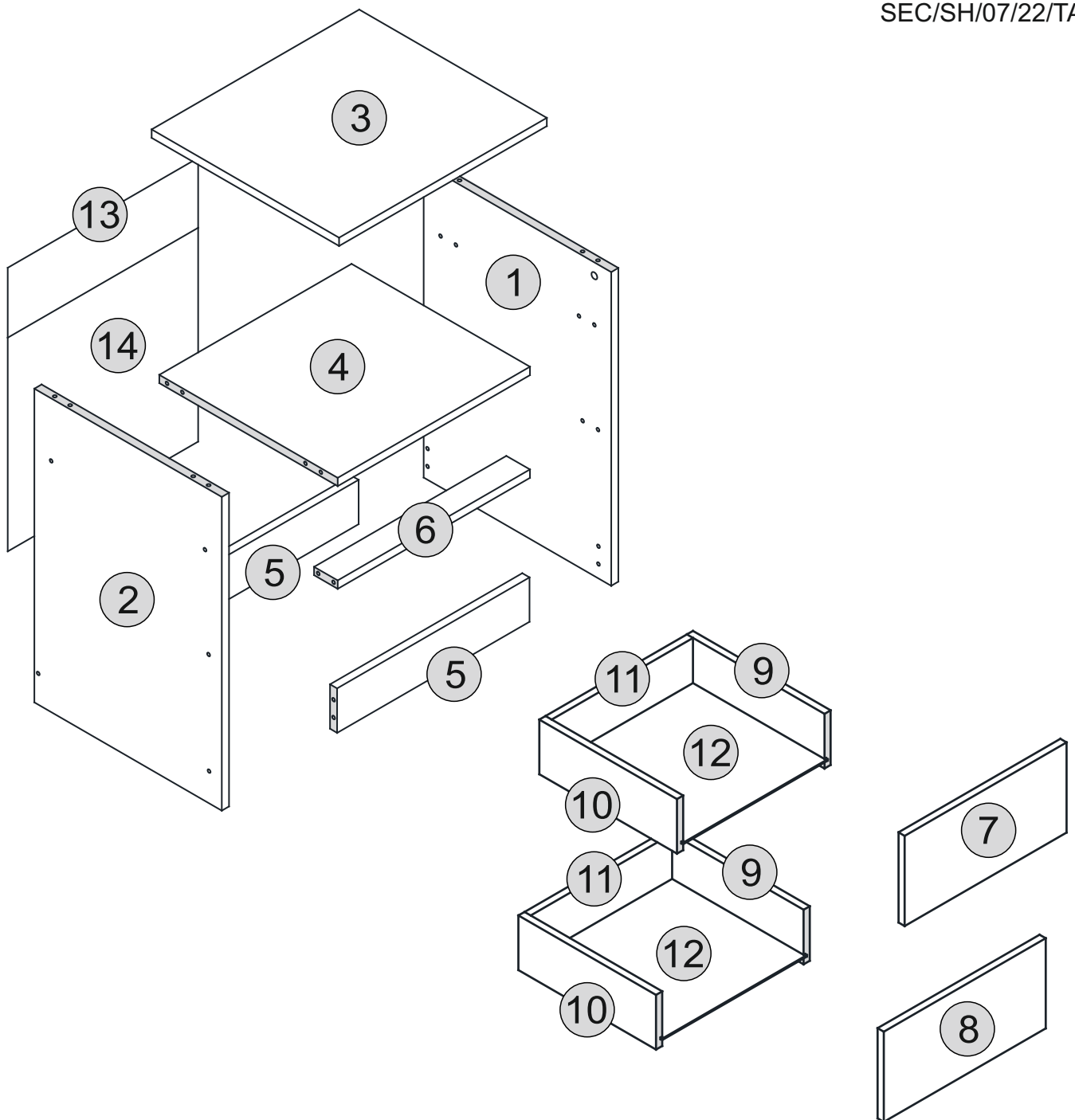







FOR CLEANING, YOU MAY USE A DAMP CLOTH (NOT WET). DO NOT USE POLISH, DETERGENT OR CHEMICAL CLEANERS.

THE SURFACE OF THIS ITEM IS NOT HEAT RESISTANT. ALWAYS USE A PLACE MAT UNDER HOT OR COLD ITEMS TO PREVENT MARKING.



Part Number	Part Code	Part Description	Quantity	Carton
1	S100-103-061-TA1-01	Right Side Panel	1	1/1
2	S100-103-061-TA1-02	Left Side Panel	1	1/1
3	S100-103-061-TA1-03	Top Panel	1	1/1
4	S100-103-061-TA1-04	Shelf	1	1/1
5	S100-103-061-TA1-05	Lower Crossbar	2	1/1
6	S100-103-061-TA1-06	Middle Crossbar	1	1/1
7	S100-103-061-TA1-07	Top Drawer Front	1	1/1
8	S100-103-061-TA1-08	Bottom Drawer Front	1	1/1
9	S100-103-061-TA1-09	Right Drawer Side	2	1/1
10	S100-103-061-TA1-10	Left Drawer Side	2	1/1
11	S100-103-061-TA1-11	Drawer Back	2	1/1
12	S100-103-061-TA1-12	Drawer Base	2	1/1
13	S100-103-061-TA1-13	Back Panel (Small)	1	1/1
14	S100-103-061-TA1-14	Back Panel	1	1/1

HARDWARE LIST

No.	Part Name		Qty
A	Wooden Dowel (6x25mm)		22
B	45mm Screw (4x45mm)		10
C	16mm Screw (3.5x14mm)		16
D	38mm Screw (4x38mm)		8
E	Cam Bolt (8032T)		8
F	Cam Nut		8
G	Handle (AL96mm)		2
H	Handle Screw		4
I	14" Drawer Slide		2
J	Plastic Foot		4
K	Nail		20
L	Screw Cover		10

TIPS FOR FITTING CAM-LOCKS

WHEN FITTING THE CAM-LOCK
ENSURE STARTING POSITION IS CORRECT
BEFORE YOU INSERT CONNECTING CAM BOLT
TURN CLOCKWISE UNTIL SECURE

CORRECT **WRONG**

Cam bolt head needs to be in centre

CAMBOLT

Tighten until shoulder is flush with panel. Do not overtighten or undertighten (see example below)



Panel **Panel**

STEP 1

PARTS REQUIRED

3 - TOP PANEL	x1
4 - SHELF	x1
5 - LOWER CROSSBAR	x2
6 - MIDDLE CROSSBAR	x1

HARDWARE REQUIRED

A		10
E		04

TOOLS REQUIRED

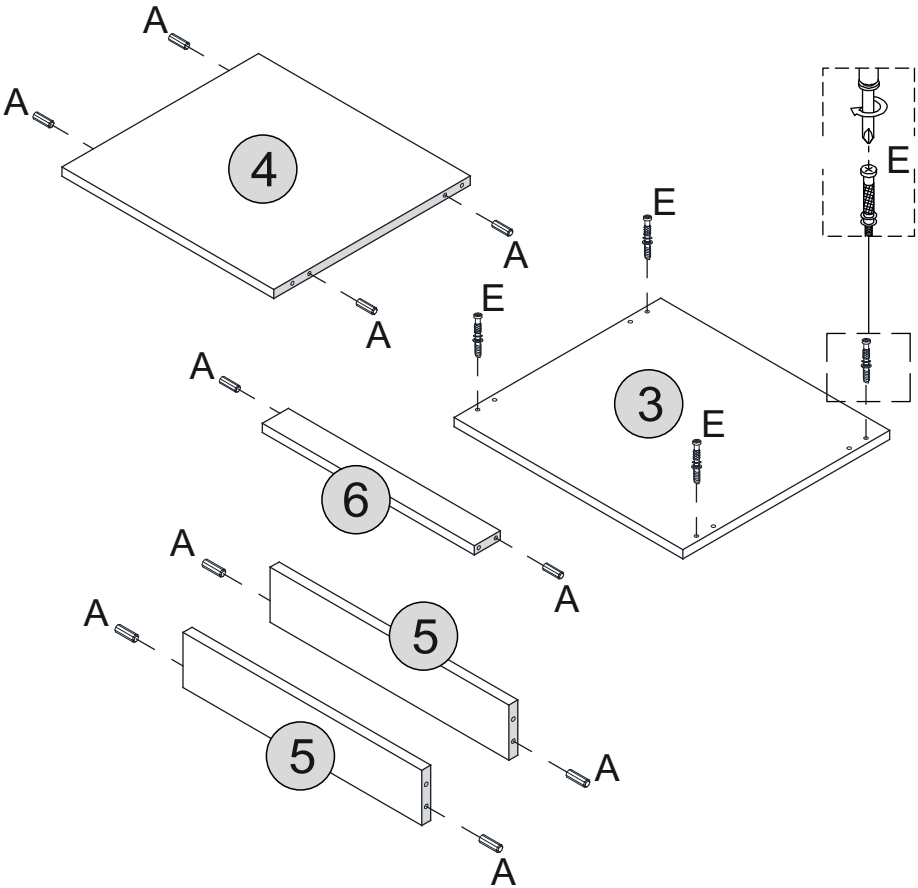
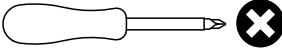





STEP 2

PARTS REQUIRED

1 - RIGHT SIDE PANEL	x1
2 - LEFT SIDE PANEL	x1

HARDWARE REQUIRED

A		04
C		08
F		04
I		04
J		04

TOOLS REQUIRED

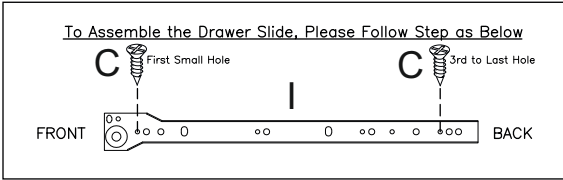
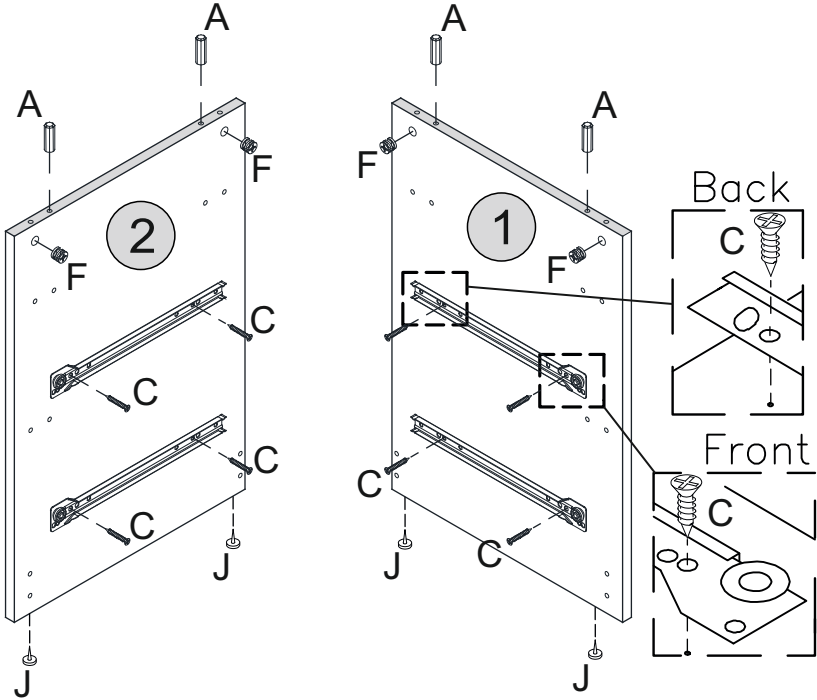
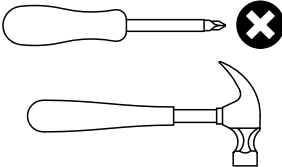

STEP 3

PARTS REQUIRED

2 - LEFT SIDE PANEL x1

4 - SHELF x1

5 - LOWER CROSSBAR x2

6 - MIDDLE CROSSBAR x1

HARDWARE REQUIRED

B  05

L  05

TOOLS REQUIRED

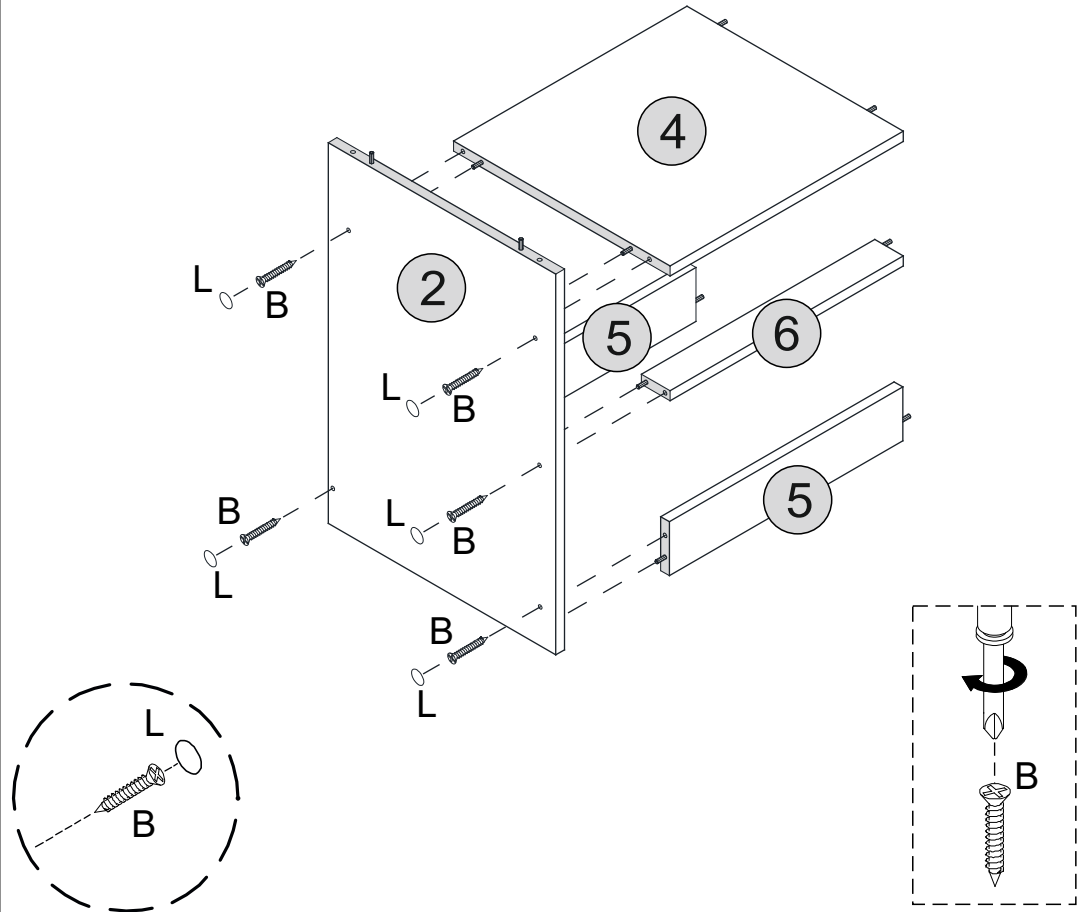
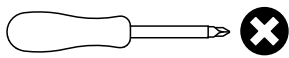

STEP 4

PARTS REQUIRED

1 - RIGHT SIDE PANEL x1

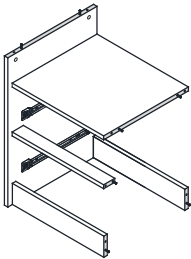

HARDWARE REQUIRED

B  05

L  05

TOOLS REQUIRED

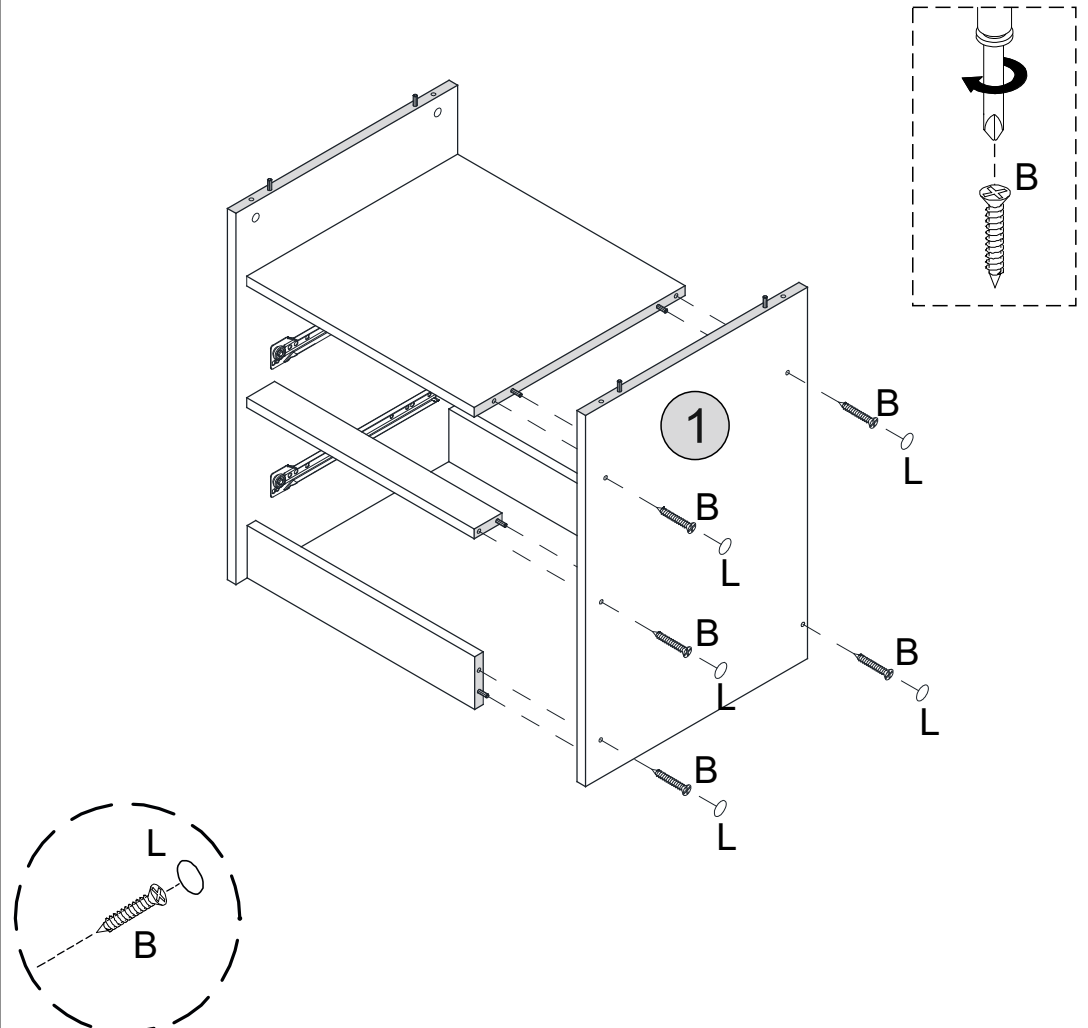
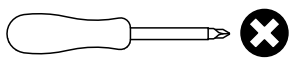

STEP 5

PARTS REQUIRED

1 - TOP PANEL x1

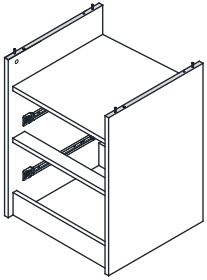

HARDWARE REQUIRED

TOOLS REQUIRED

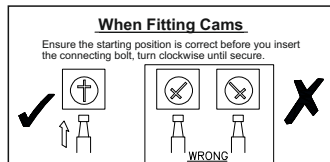
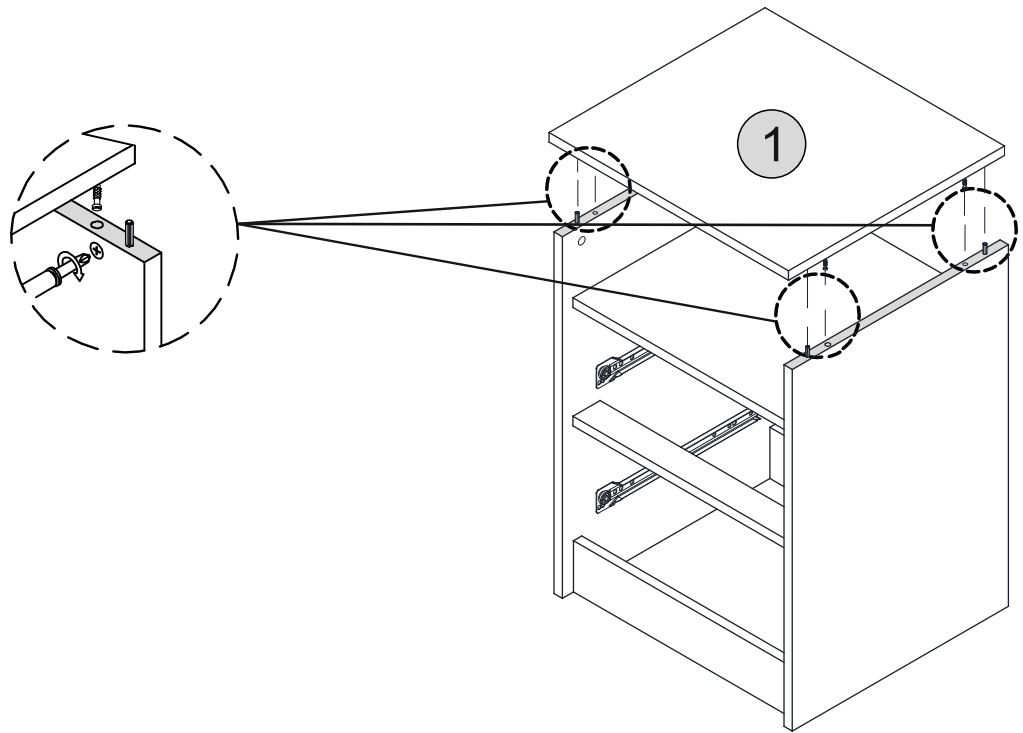
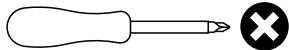

STEP 6

PARTS REQUIRED

13 - BACK PANEL (SMALL) x1

14 - BACK PANEL x1

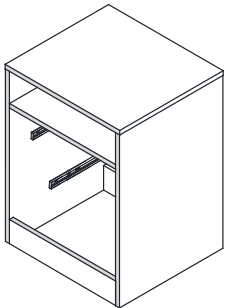

HARDWARE REQUIRED

K  20

TOOLS REQUIRED

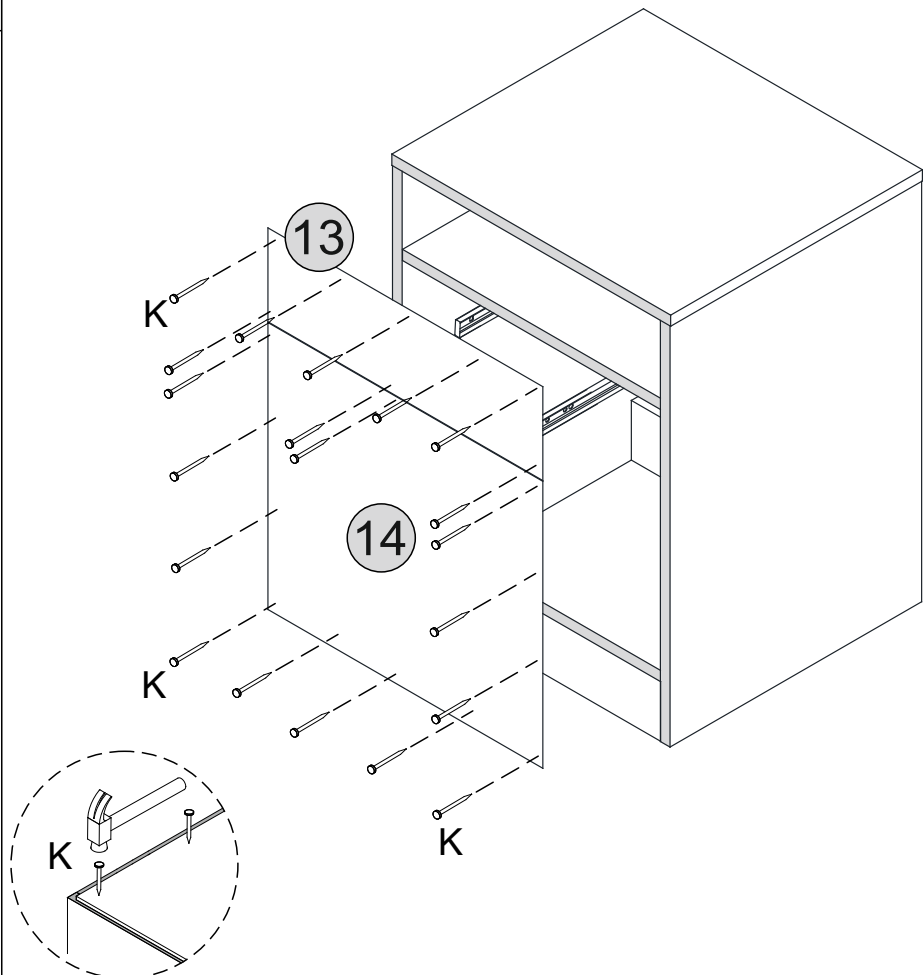
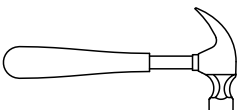



STEP 7

PARTS REQUIRED

7 - TOP DRAWER FRONT	x1
8 - BOTTOM DRAWER FRONT	x1
9 - RIGHT DRAWER SIDE	x2
10 - LEFT DRAWER SIDE	x2

HARDWARE REQUIRED

A		08
E		04
F		04

TOOLS REQUIRED

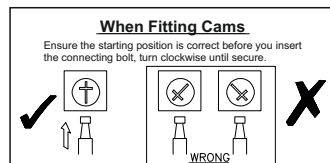
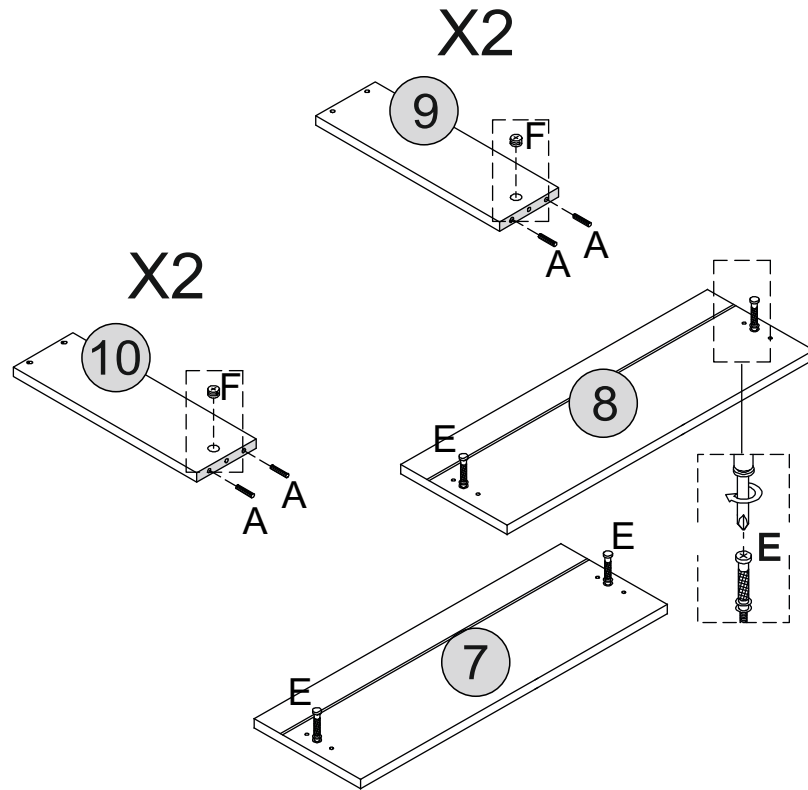
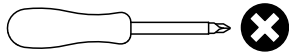

STEP 8

PARTS REQUIRED

9 - RIGHT DRAWER SIDE	x2
10 - LEFT DRAWER SIDE	x2
11 - DRAWER BACK	x2
12 - DRAWER BASE	x2

HARDWARE REQUIRED

D		08
---	---	----

TOOLS REQUIRED

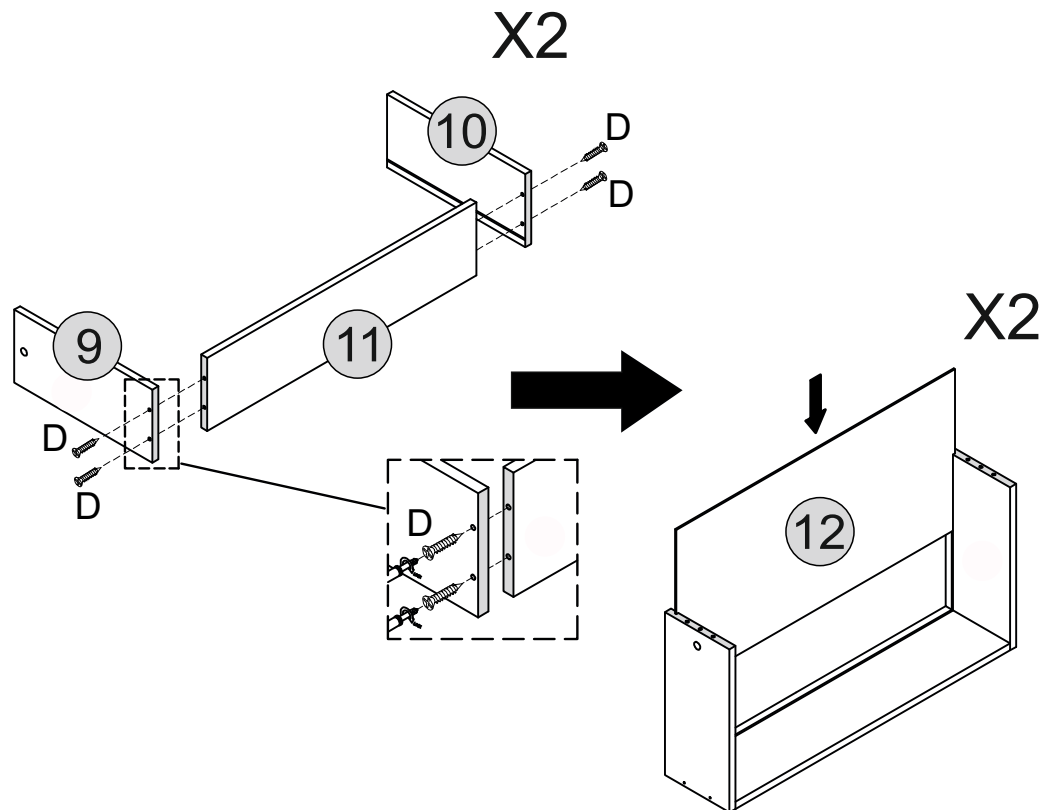
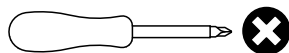

STEP 9

PARTS REQUIRED

7 - TOP DRAWER FRONT x1

8 - BOTTOM DRAWER FRONT x1

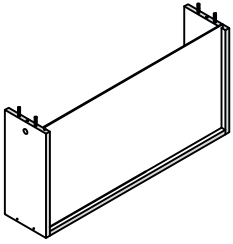

HARDWARE REQUIRED

TOOLS REQUIRED

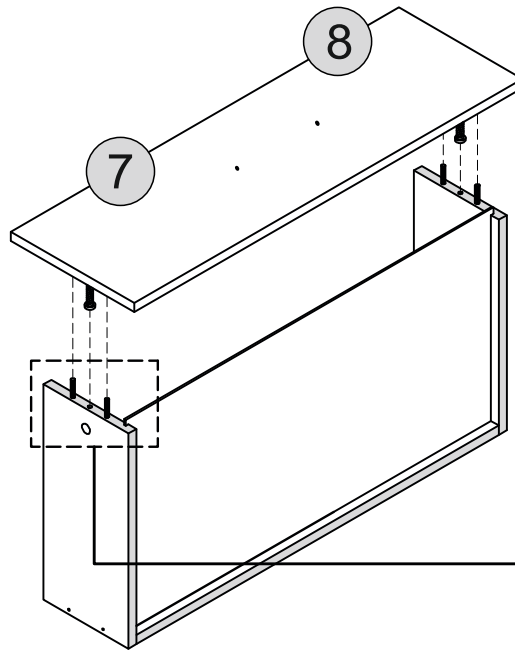
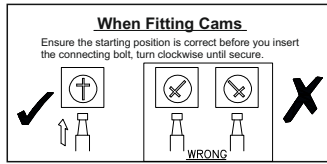
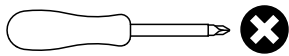

X2

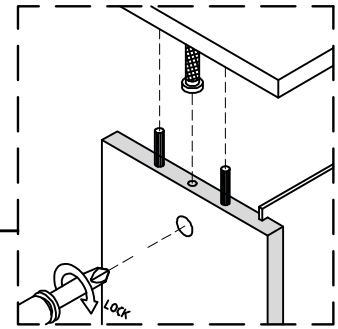

STEP 10

PARTS REQUIRED

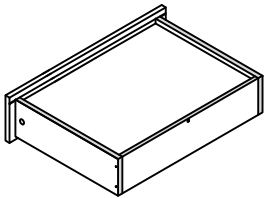

HARDWARE REQUIRED

C  08

I  04

TOOLS REQUIRED

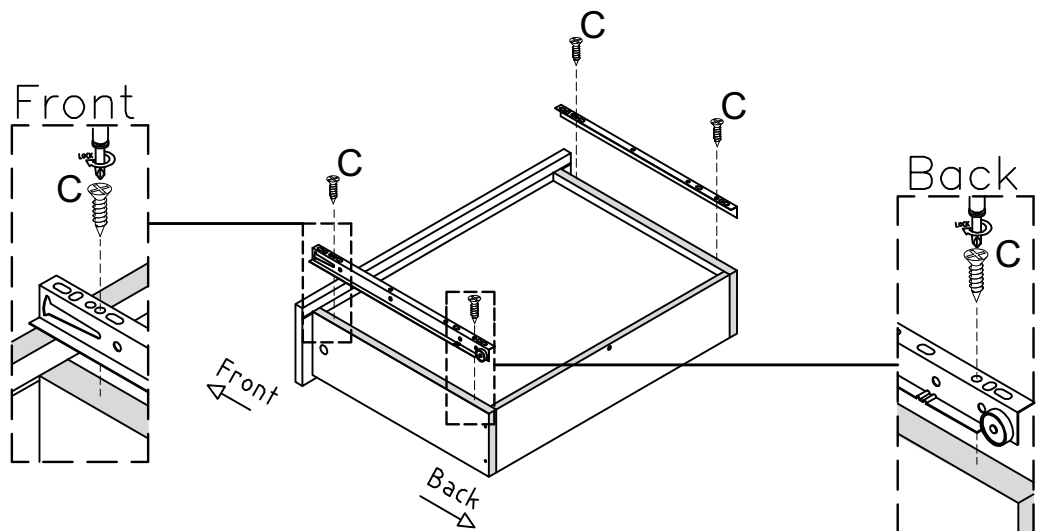
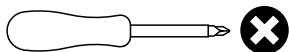

X2

STEP 11

PARTS REQUIRED

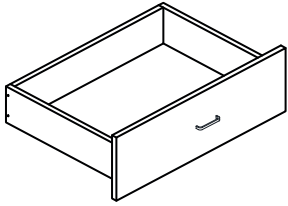

HARDWARE REQUIRED



TOOLS REQUIRED

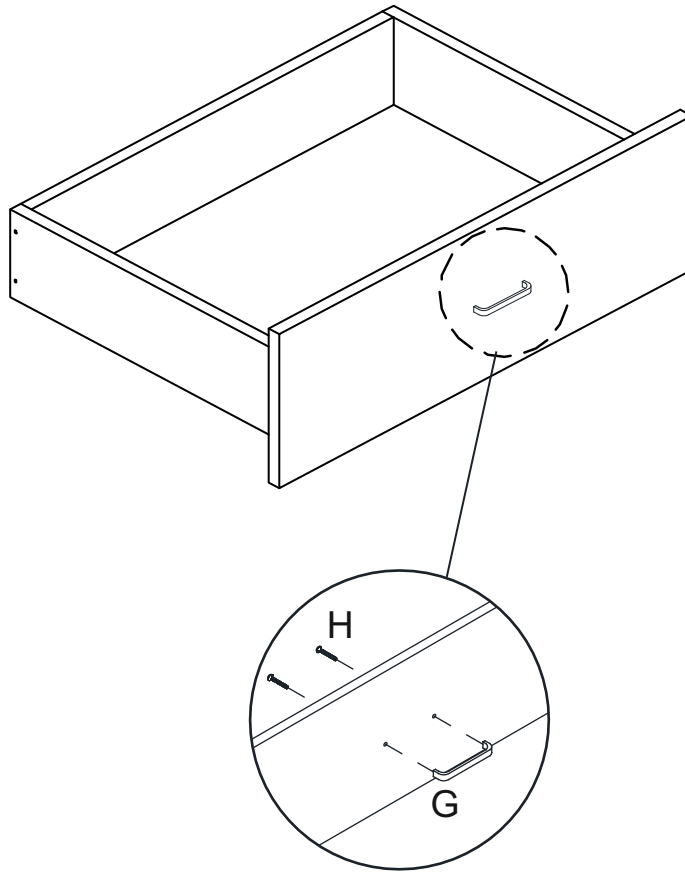
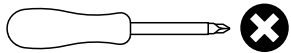

X2

STEP 12

PARTS REQUIRED

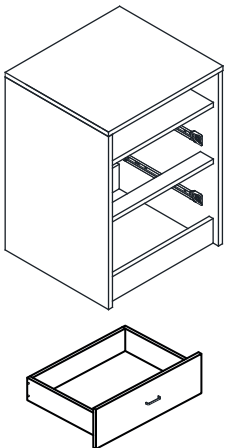

HARDWARE REQUIRED

TOOLS REQUIRED

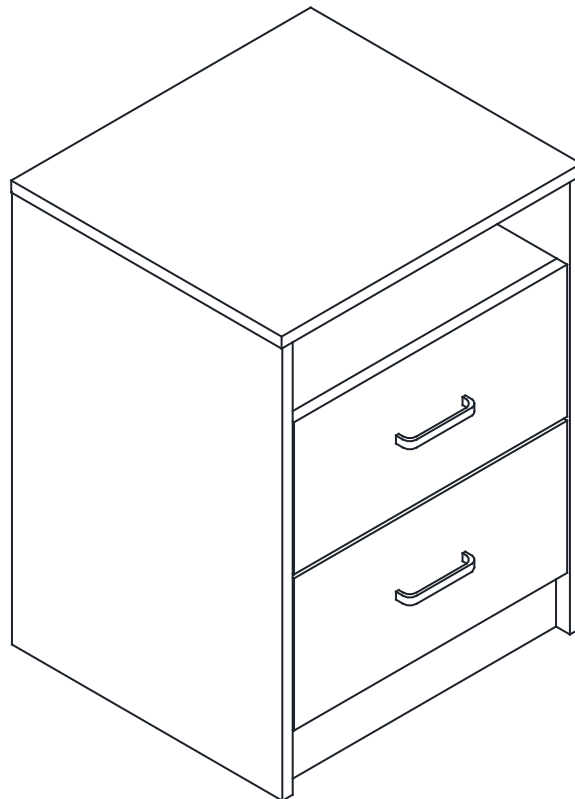

FINISH