

MADRID BEDSIDE ASSEMBLY INSTRUCTIONS

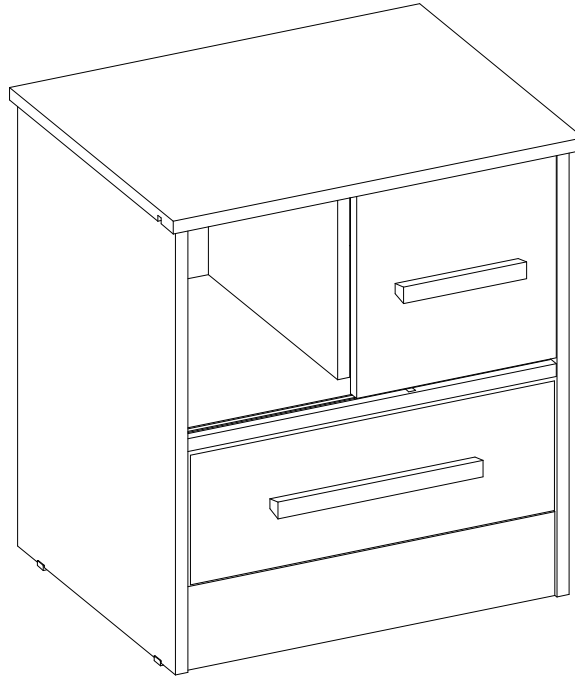
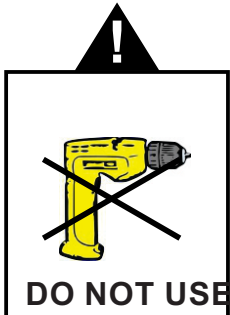

IMPORTANT FOR DOMESTIC USE ONLY

PLEASE READ BEFORE YOU CONTINUE FURTHER

CARE AND MAINTENANCE

- After unpacking this product please keep the original packaging in case it needs to be returned for any reason.
- Please ensure all fittings and parts are present before commencing with assembly.
 - Never drag or push products as this could cause damage to the joints making it inferior.
 - We strongly recommend that you keep children away from your work area.
 - We recommend that you lay a blanket or sheet on the floor to avoid damage to both your floor and the product.
 - Assemble this product as close to its final position as possible.
 - Do not place this product next to a radiator or in direct sunlight.
 - Do not drag or push items across your high gloss furniture as this may cause the surface to scratch
 - Wood is a natural product and may expand if subjected to damp and may shrink or crack if subjected to heat. Therefore it is recommended that room temperature is maintained, with no sudden temperature fluctuations.
 - Make sure any spillage is wiped off immediately.
 - Do not place hot or chilled items directly on to the surface, use a place mat or marking will occur.
 - For general cleaning use a soft cotton or micro fibre cloth, and do not use detergents of any kind.
 - From time to time it may be necessary to tighten fittings, regular inspections should be carried out.
 - Do not place on a wet or damp floor as staining may occur to your floor.

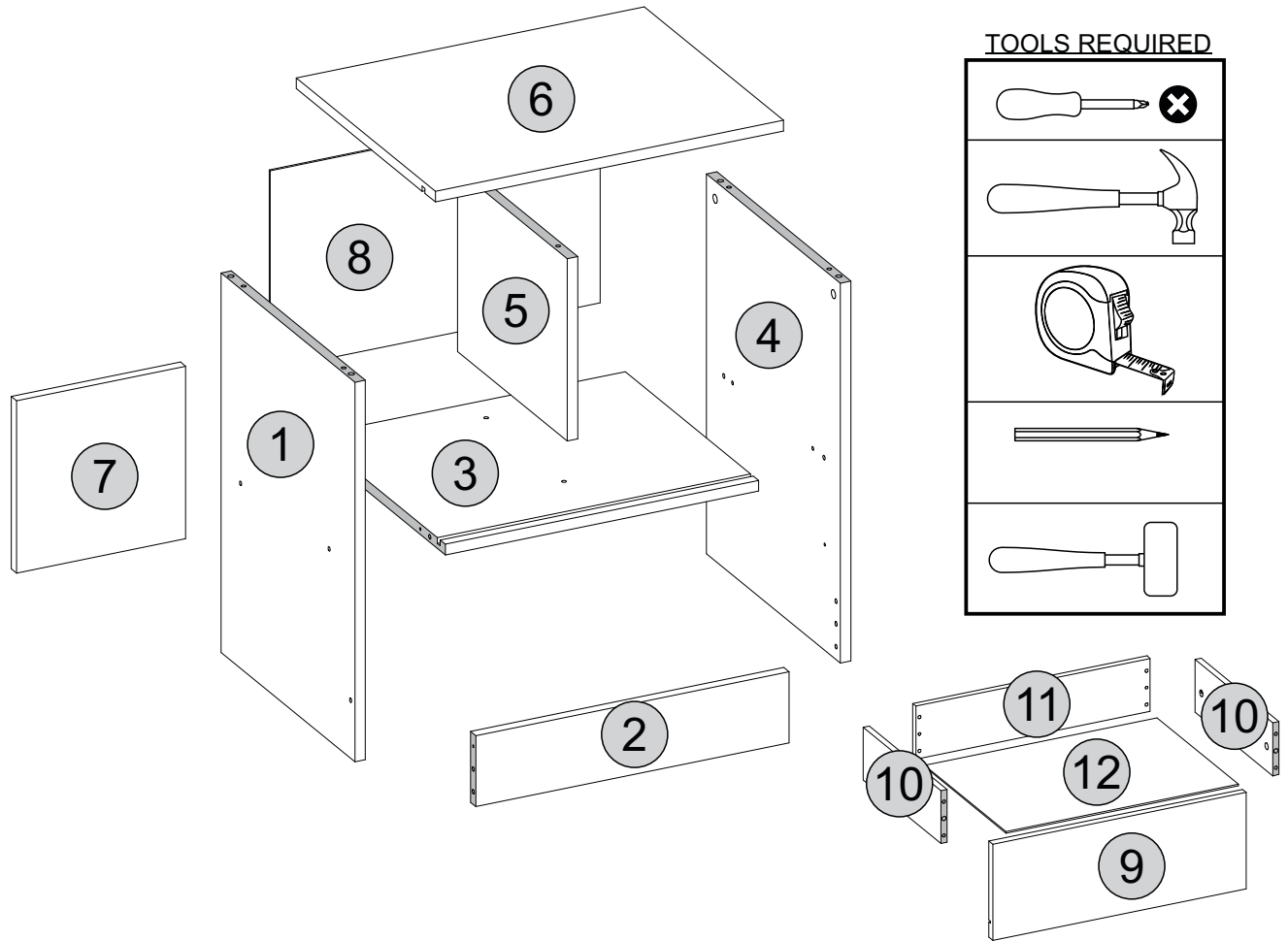







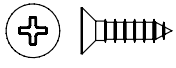
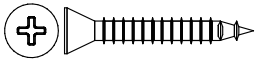
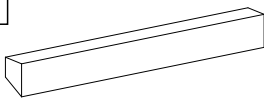

PARTS LIST

Please Note:

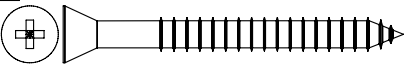
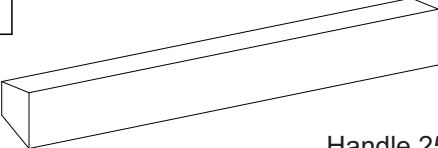
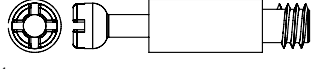
The below parts have all been stamped with the part number to help identify them during assembly.

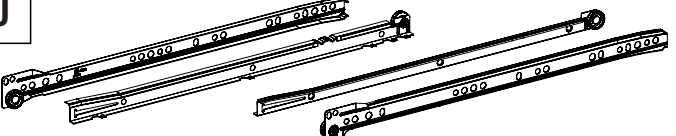
Part Number	Part Code	Part Description	Quantity	Carton
1	S100-103-079-AL1-01	Left Side Panel	1	1/1
2	S100-103-079-AL1-02	Crossbeam	1	1/1
3	S100-103-079-AL1-03	Base Panel	1	1/1
4	S100-103-079-AL1-04	Right Side Panel	1	1/1
5	S100-103-079-AL1-05	Division Panel	1	1/1
6	S100-103-079-AL1-06	Top Panel	1	1/1
7	S100-103-079-AL1-07	Door	1	1/1
8	S100-103-079-AL1-08	Back Panel	1	1/1
9	S100-103-079-AL1-09	Drawer Front	1	1/1
10	S100-103-079-AL1-10	Drawer Side	2	1/1
11	S100-103-079-AL1-11	Drawer Back Panel	1	1/1
12	S100-103-079-AL1-12	Drawer Bottom	1	1/1

FITTINGS LIST

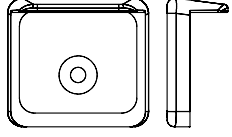
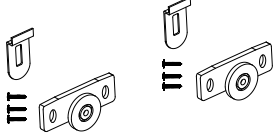
<p>A</p>  <p>+2 Flat Head Screw Ø3,0 x 12mm (10x)</p>	<p>B</p>  <p>+1 Flat Head Screw Ø3,5 x 25mm (4x)</p>	<p>C</p>  <p>Handle 150 mm (1x)</p>	<p>D</p>  <p>+2 Dowel Ø6,0 x 30mm (24x)</p>
<p>E</p>  <p>+1 Flat Head Screw Ø4,5 x 45mm (6x)</p>	<p>F</p>  <p>Handle 250 mm (1x)</p>		<p>G</p>  <p>+1 Cam Bolt (8x)</p>
<p>H</p>  <p>+1 Cam Nut (8x)</p>	<p>I</p>  <p>+2 Hole Plugs (14x)</p>	<p>J</p>  <p>Drawer Runners 300mm (1x)</p>	
<p>K</p>  <p>+2 Nail 10 x 10 (20x)</p>	<p>L</p>  <p>Rail (2x)</p>	<p>M</p>  <p>Glue (1x)</p>	
<p>N</p>  <p>+1 Plastic Foot (4x)</p>	<p>O</p>  <p>Sliding Door System (1x)</p>		

TIPS FOR FITTINGS CAM-LOCKS

WHEN FITTING CAM NUT, ENSURE STARTING POSITION IS CORRECT BEFORE YOU INSERT CONNECTING CAM BOLT TURN CLOCKWISE UNTIL SECURE

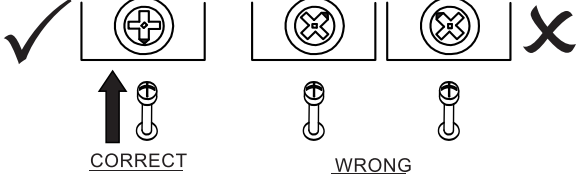

CORRECT **WRONG**

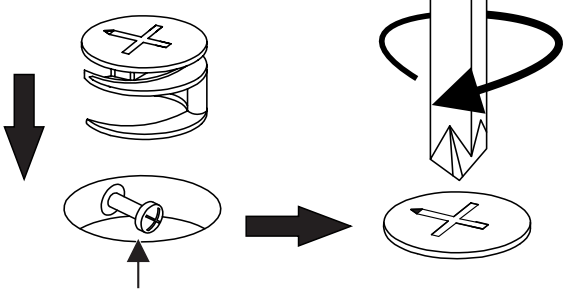

Cam bolt head needs to be in centre

CAMBOLT

Tighten until shoulder in flush with panel. Do not overtighten or undertighten (see example beside)

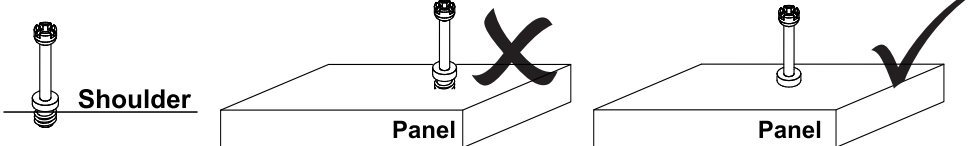



Shoulder **Panel** **Panel**

STEP 1

PARTS REQUIRED

1 - LEFT SIDE PANEL	x1
2 - CROSSBEAM	x1
3 - BASE PANEL	x1
4 - RIGHT SIDE PANEL	x1
5 - DIVISION PANEL	x1

HARDWARE REQUIRED

D	 Ø6,0 x 30mm	16
M	 Glue	01

TOOLS REQUIRED

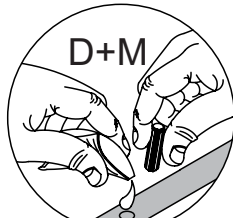
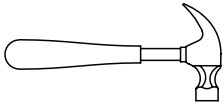

Detail 2

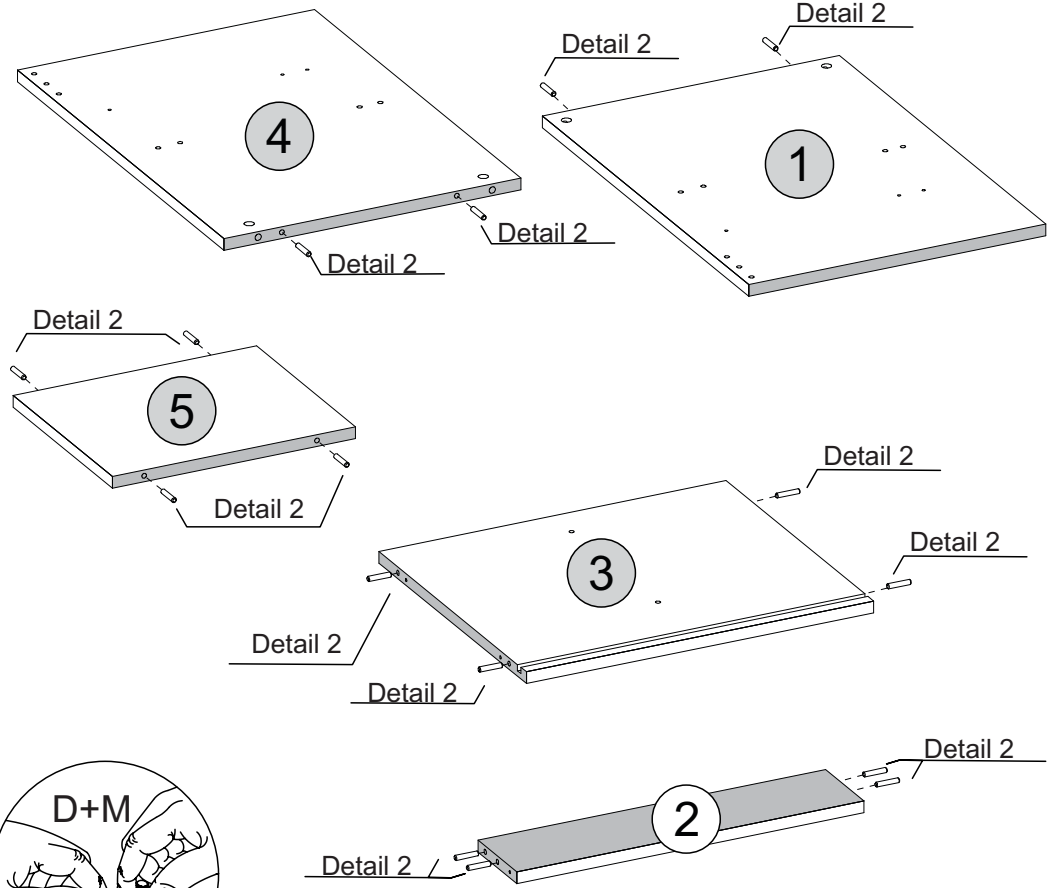



STEP 2

PARTS REQUIRED

1 - LEFT SIDE PANEL	x1
4 - RIGHT SIDE PANEL	x1

HARDWARE REQUIRED

K	 10 x 10	04
N		04

TOOLS REQUIRED

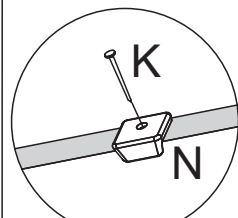
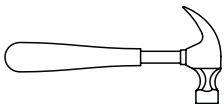

Detail 16

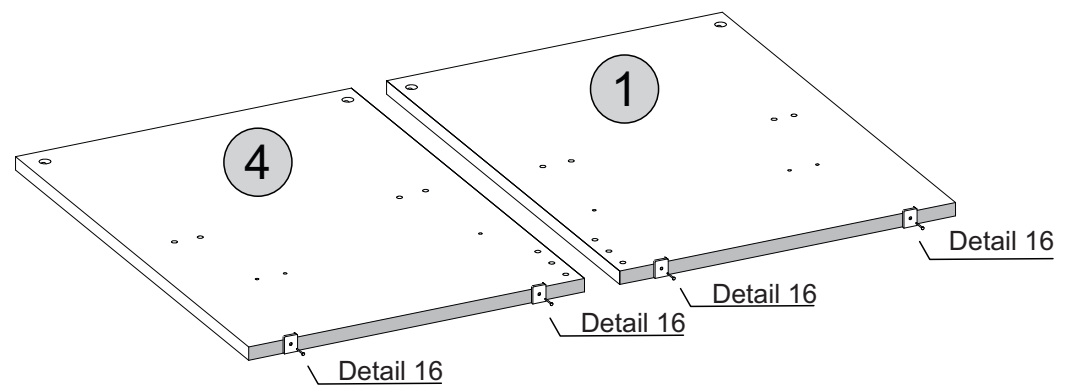



STEP 3

PARTS REQUIRED

- 1 - LEFT SIDE PANEL x1
- 4 - RIGHT SIDE PANEL x1

HARDWARE REQUIRED

- A  04
Ø3,0 x 12mm
- J  Right 01
- J  Left 01

TOOLS REQUIRED

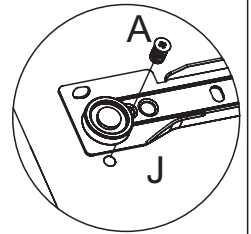
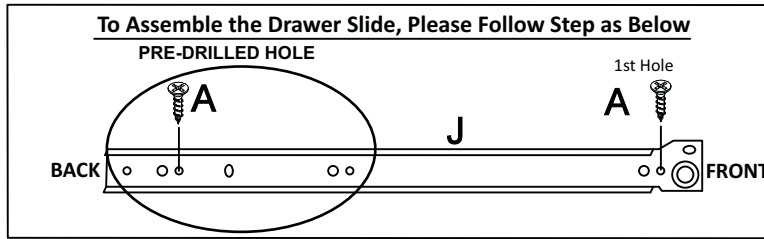
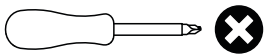

Detail 1

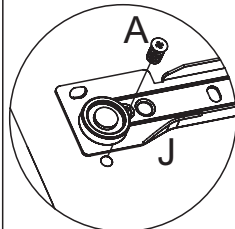
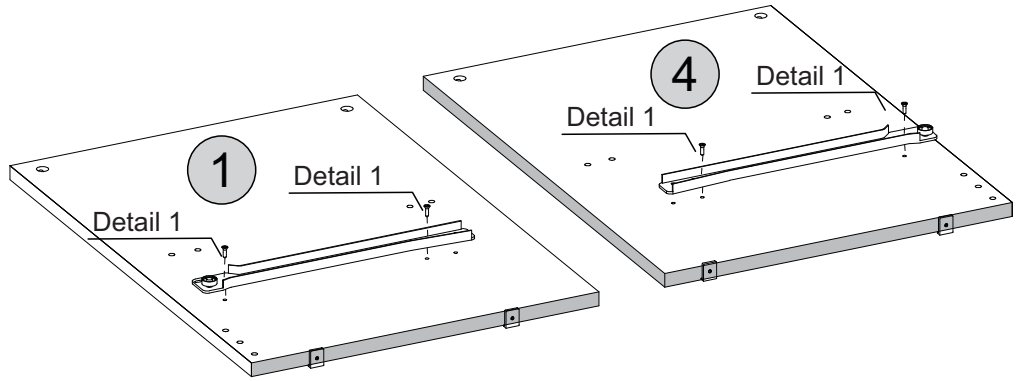

Detail 1

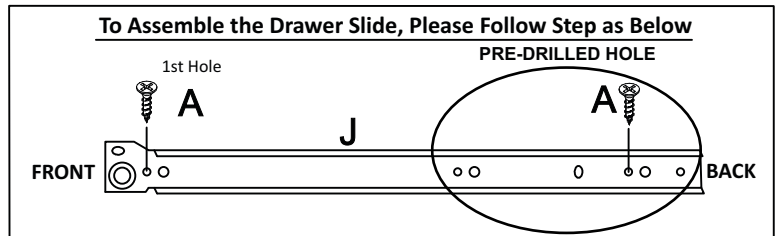

STEP 4

PARTS REQUIRED

- 6 - TOP PANEL x1

HARDWARE REQUIRED

- G  04

TOOLS REQUIRED

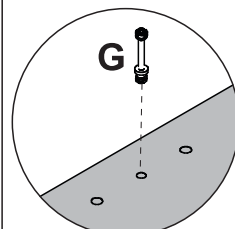
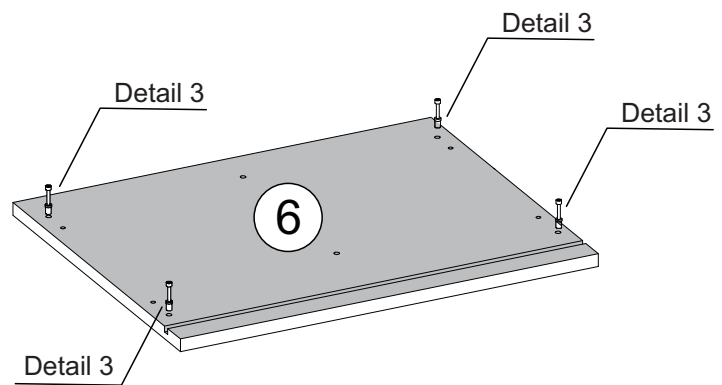
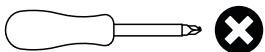

Detail 3

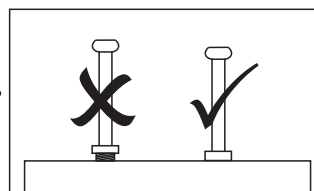

STEP 5

PARTS REQUIRED

3 - BASE PANEL x1

HARDWARE REQUIRED

L  01

TOOLS REQUIRED

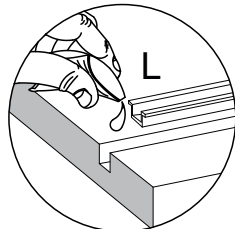
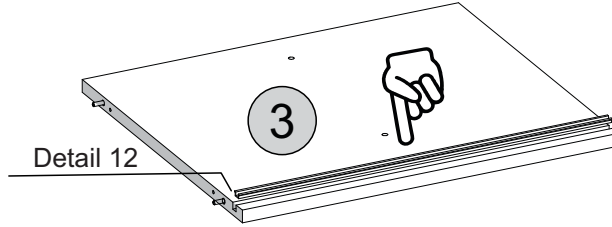
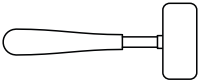

Detail 12

STEP 6

PARTS REQUIRED

1 - LEFT SIDE PANEL x1

3- BASE PANEL x1

HARDWARE REQUIRED

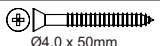
E  02
Ø4,0 x 50mm

M  01

TOOLS REQUIRED

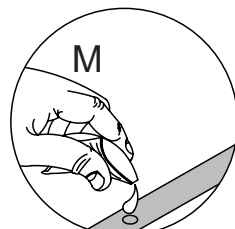
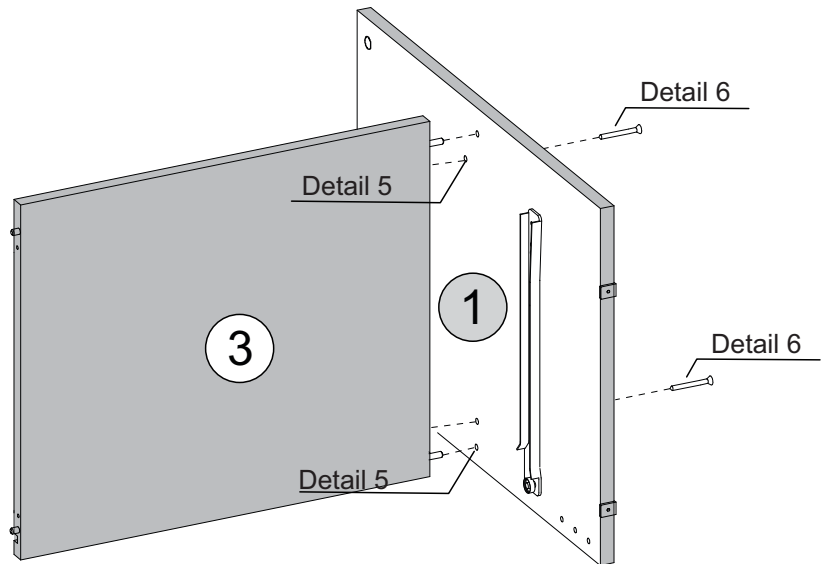
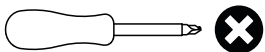

Detail 5

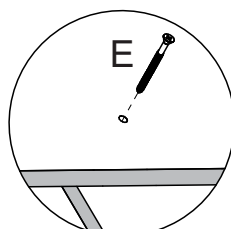

Detail 6

STEP 7

PARTS REQUIRED

2 - CROSSBEAM x1

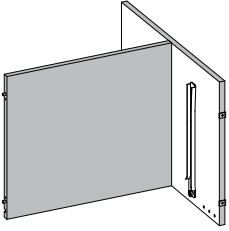

HARDWARE REQUIRED

E  01
Ø4,0 x 50mm

M  01

TOOLS REQUIRED

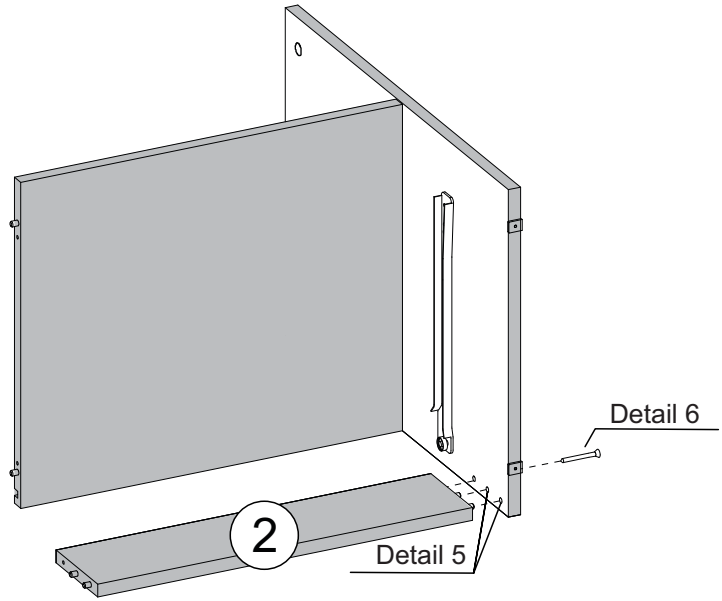
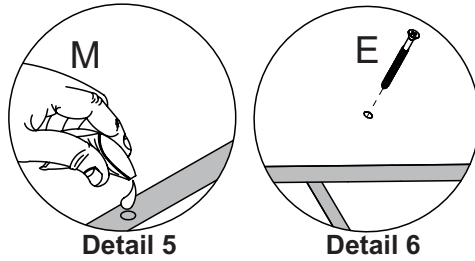
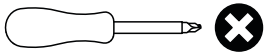

STEP 8

PARTS REQUIRED

4 - RIGHT SIDE PANEL x1

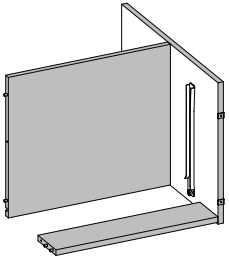

HARDWARE REQUIRED

E  02
Ø4,0 x 50mm

M  01

TOOLS REQUIRED

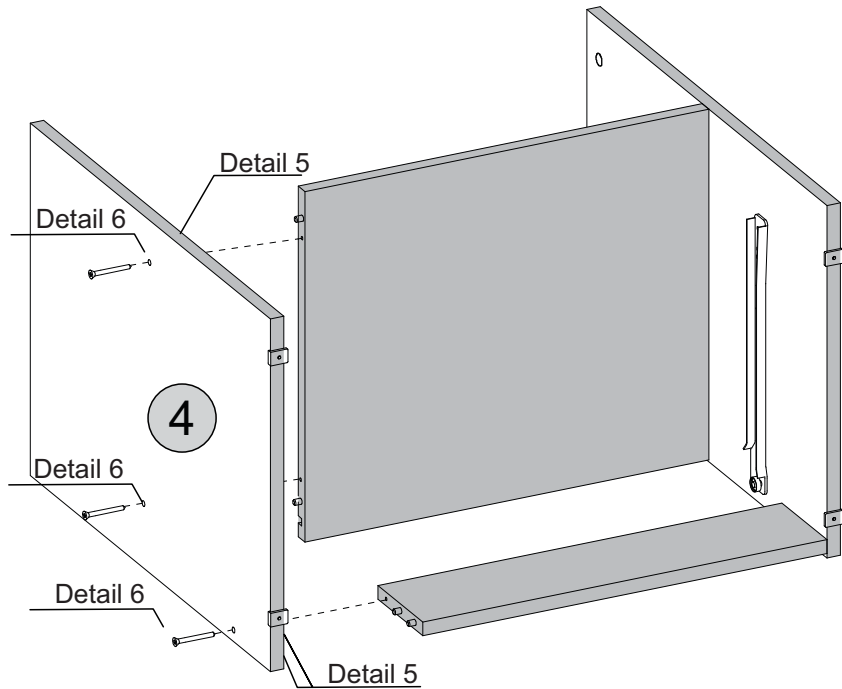
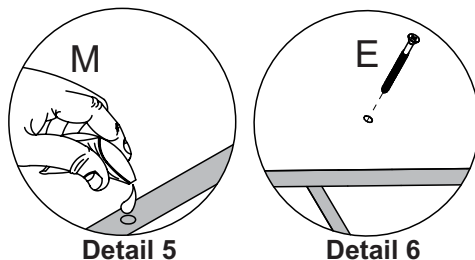
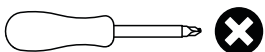

STEP 9

PARTS REQUIRED

5 - DIVISION PANEL x1

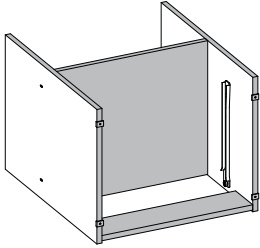

HARDWARE REQUIRED

M  01

TOOLS REQUIRED

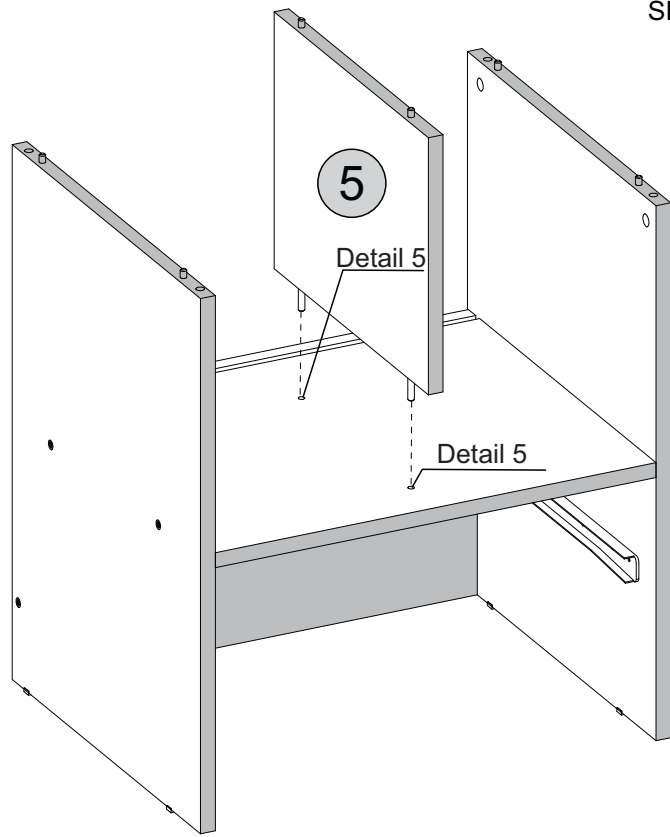
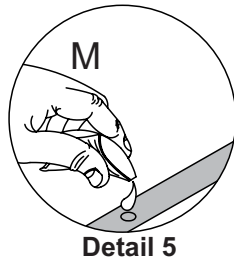

STEP 10

PARTS REQUIRED

6 - TOP PANEL x1

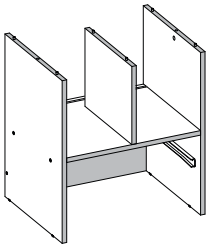

HARDWARE REQUIRED

I  04

M  01

H  04

TOOLS REQUIRED

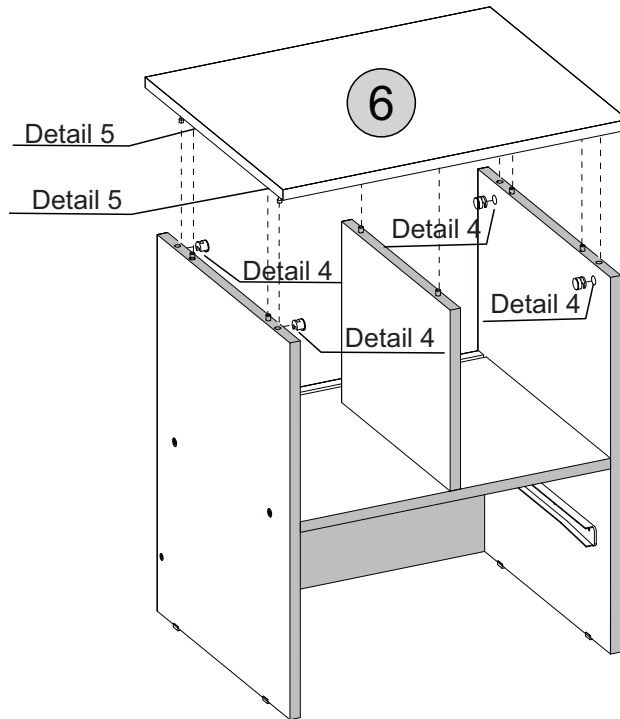
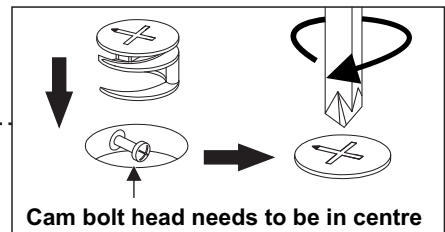
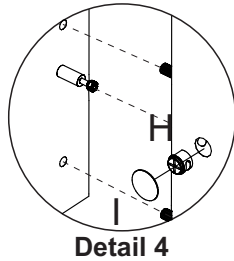
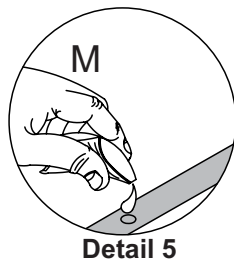
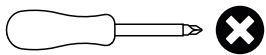

STEP 11

PARTS REQUIRED

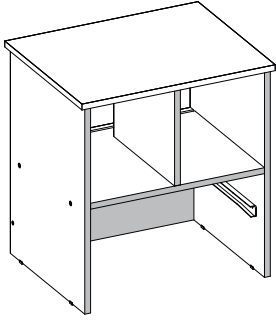

HARDWARE REQUIRED

M		01
L		01

TOOLS REQUIRED

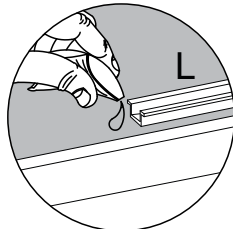
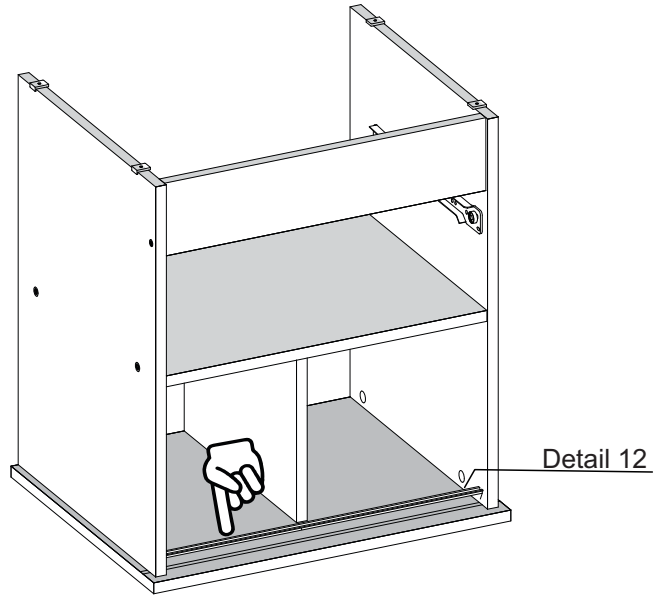
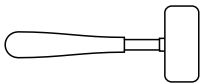

Detail 12

STEP 12

PARTS REQUIRED

7 - DOOR	x1
----------	----

HARDWARE REQUIRED

O		01
---	--	----

TOOLS REQUIRED

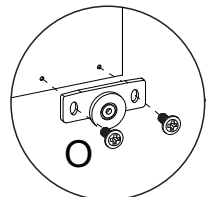
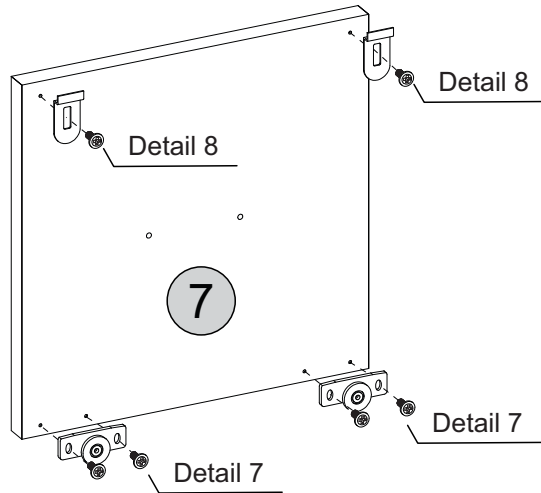
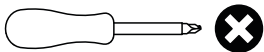

Detail 7

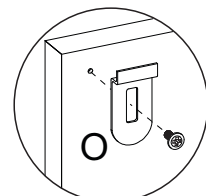
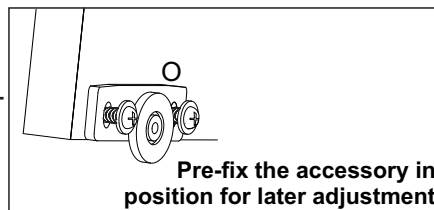

Detail 8

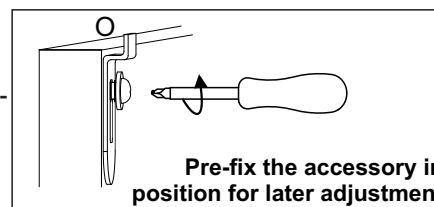



STEP 13

PARTS REQUIRED

7 - DOOR x1

HARDWARE REQUIRED

B  02
Ø3,5 x 25mm

C  01

TOOLS REQUIRED

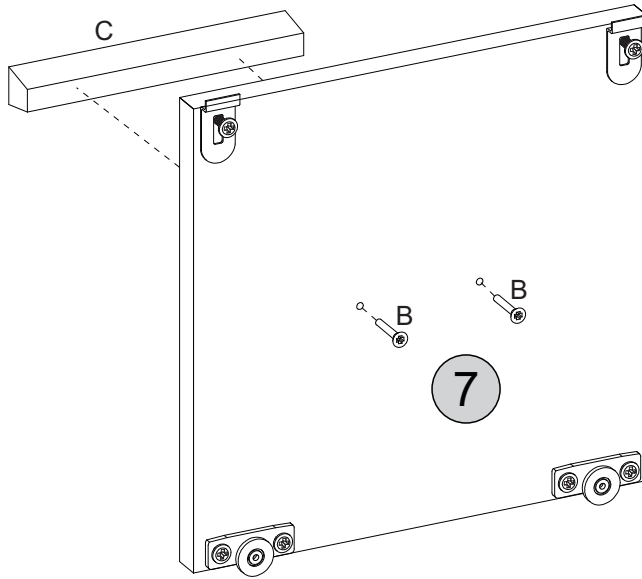
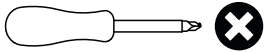

STEP 14

PARTS REQUIRED

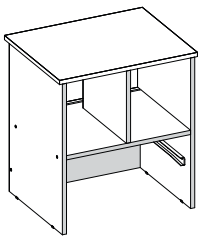

HARDWARE REQUIRED

TOOLS REQUIRED

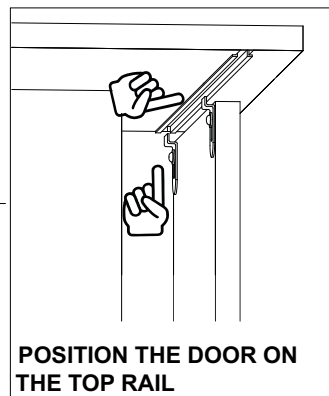
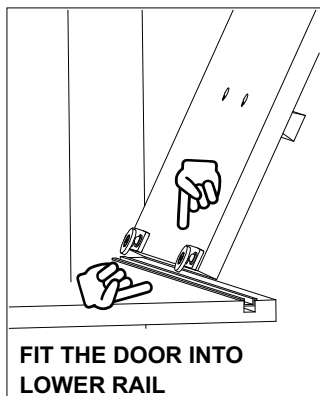
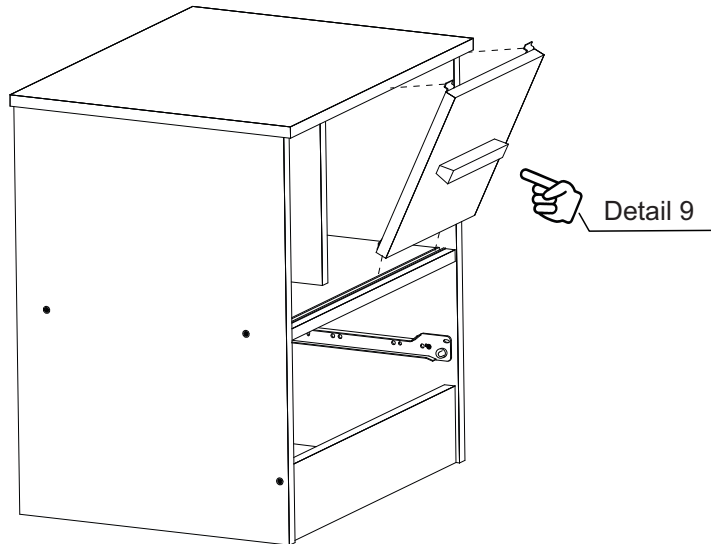

Detail 9

STEP 15

PARTS REQUIRED

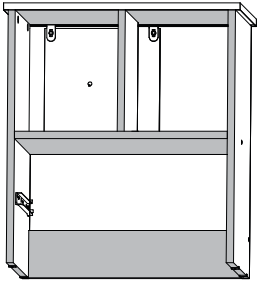

HARDWARE REQUIRED

TOOLS REQUIRED

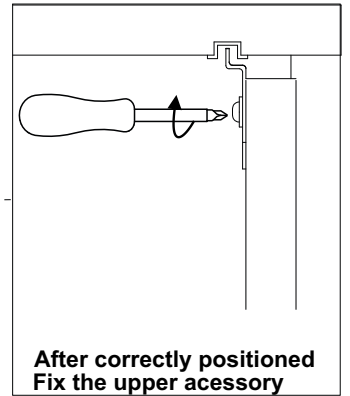
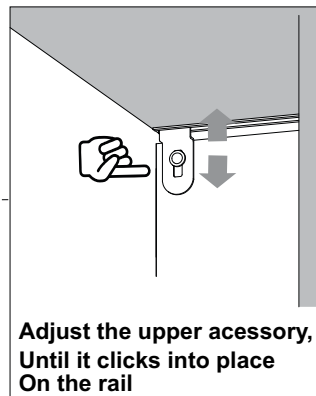
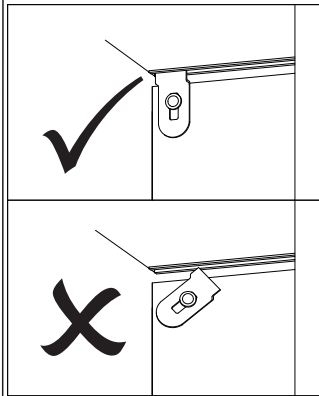
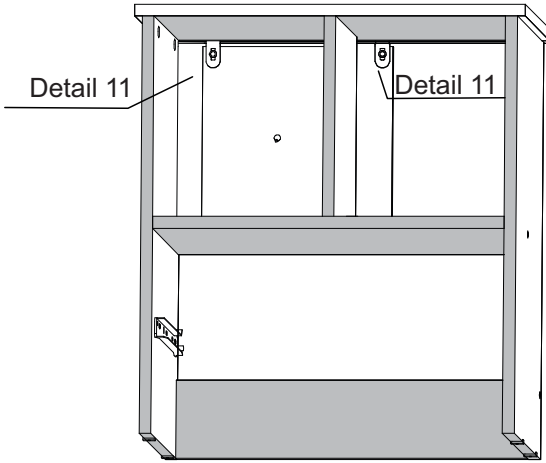
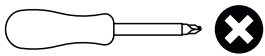

**Adjust the upper accessory,
Until it clicks into place
On the rail**

**After correctly positioned
Fix the upper accessory**

Detail 11

STEP 16

PARTS REQUIRED

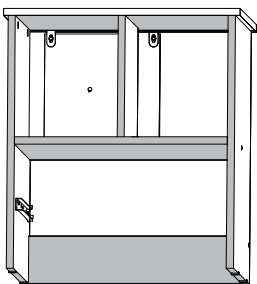

HARDWARE REQUIRED

TOOLS REQUIRED

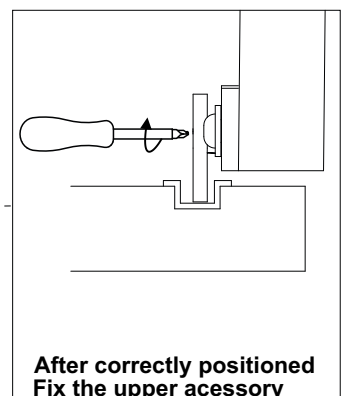
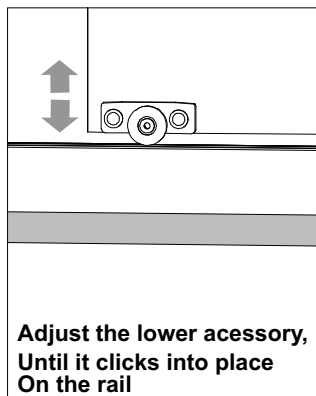
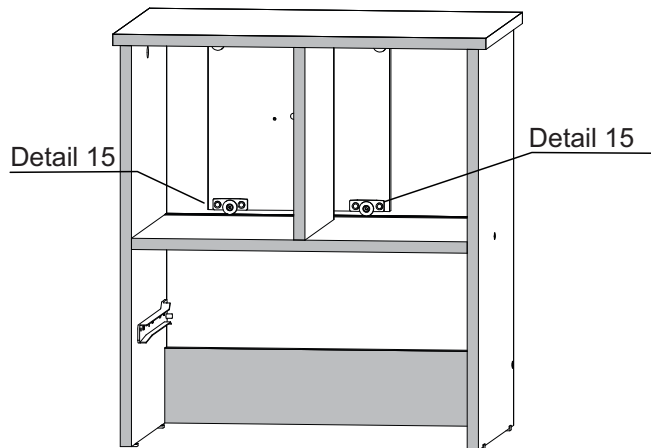
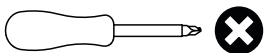

**Adjust the lower accessory,
Until it clicks into place
On the rail**

**After correctly positioned
Fix the upper accessory**

Detail 15

STEP 17

PARTS REQUIRED

8 - BACK PANEL x1

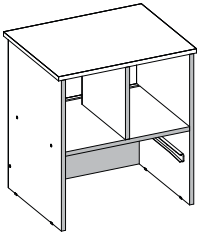

HARDWARE REQUIRED

K  10 x 10 10

TOOLS REQUIRED

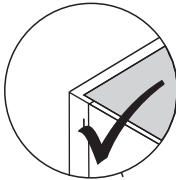
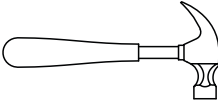

* For your future reference Order Number should be here

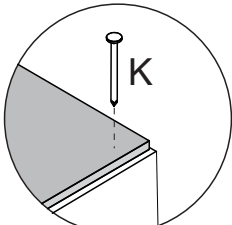
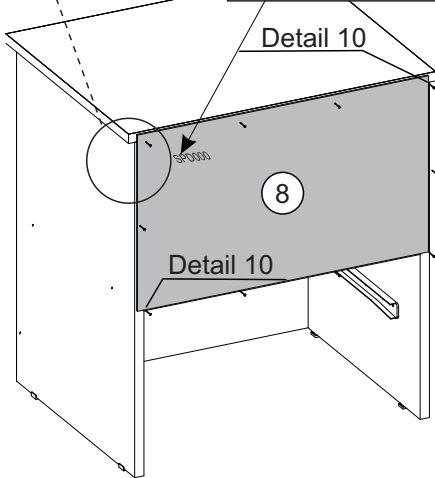

Detail 10

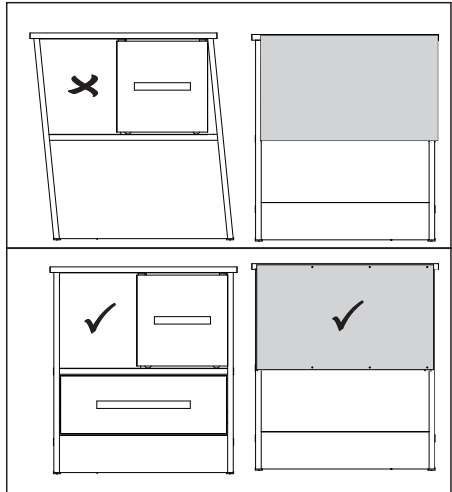



STEP 18

PARTS REQUIRED

10- DRAWER SIDE x2

HARDWARE REQUIRED

D  Ø6,0 x 30mm 08

M  Glue 01

TOOLS REQUIRED

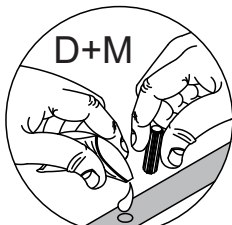
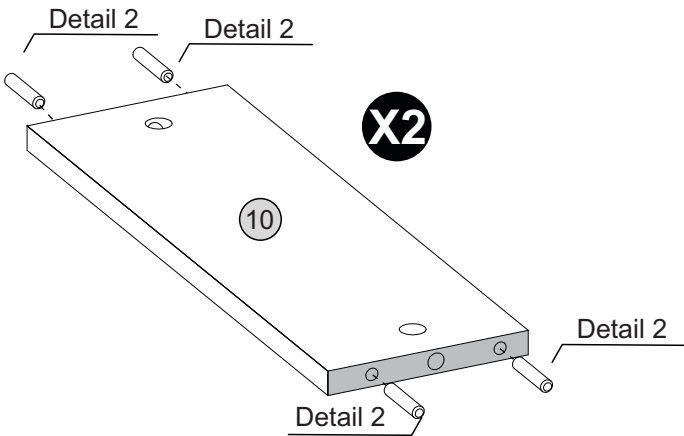
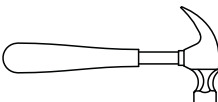

Detail 2

STEP 19

PARTS REQUIRED

11 - DRAWER BACK PANEL x1

HARDWARE REQUIRED

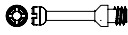
G  02

TOOLS REQUIRED

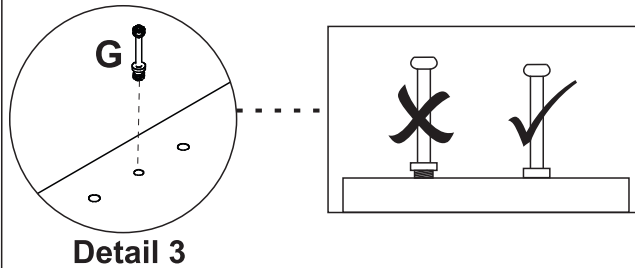
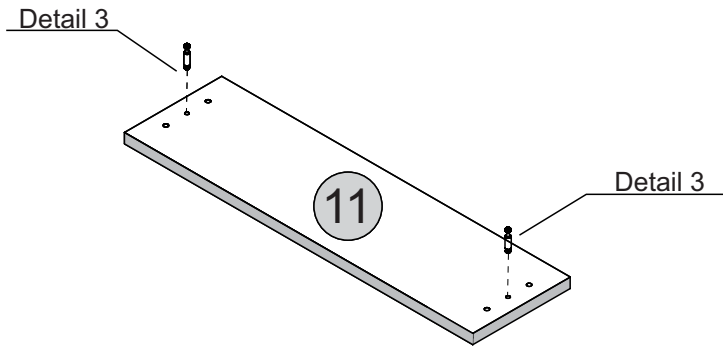
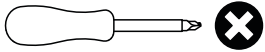

STEP 20

PARTS REQUIRED

9 - DRAWER FRONT x1

HARDWARE REQUIRED

G  02

TOOLS REQUIRED

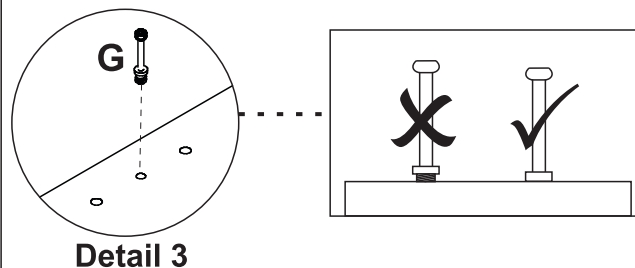
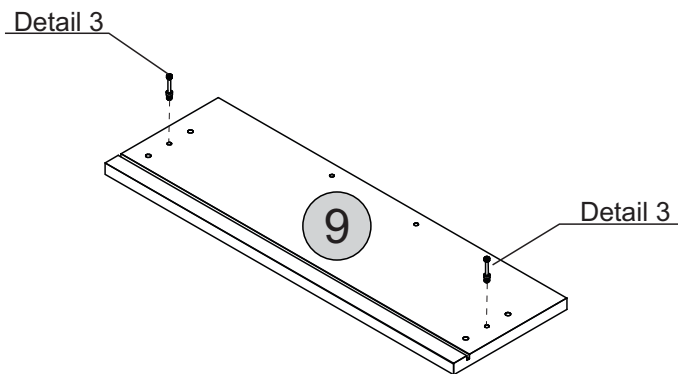
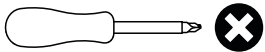

STEP 21

PARTS REQUIRED

10 - DRAWER SIDE x2

11 - DRAWER BACK PANEL x1

HARDWARE REQUIRED

I  02

M  01

H  02

TOOLS REQUIRED

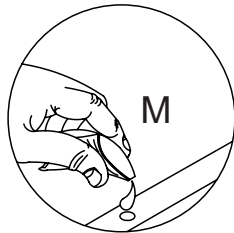
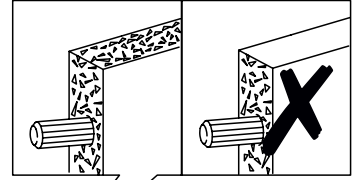
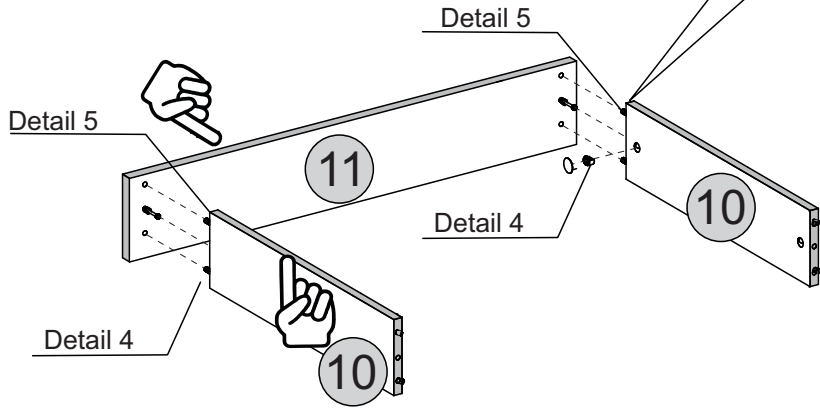
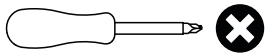

Detail 5

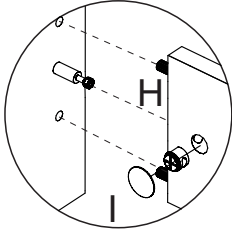

Detail 4

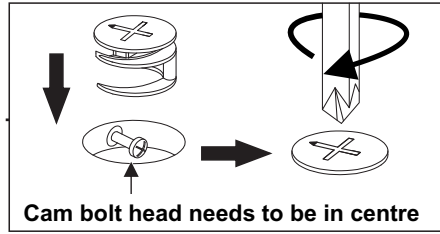

Cam bolt head needs to be in centre

STEP 22

PARTS REQUIRED

9 - DRAWER FRONT x1

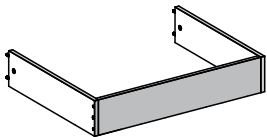

HARDWARE REQUIRED

I  02

M  01

H  02

TOOLS REQUIRED

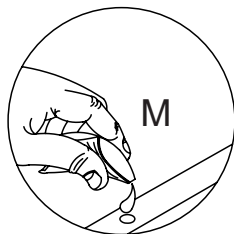
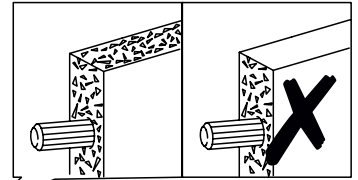
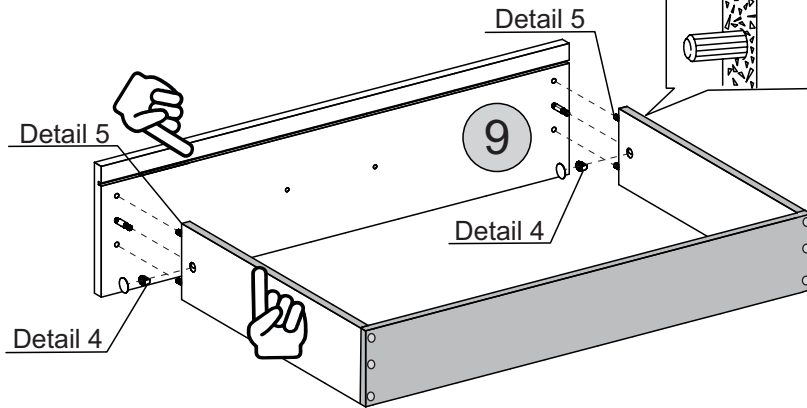
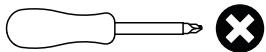

Detail 5

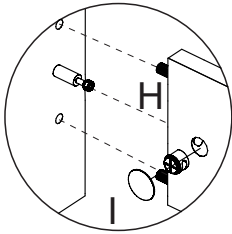

Detail 4

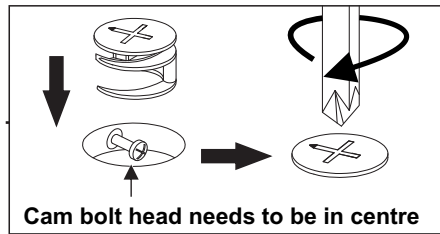

Cam bolt head needs to be in centre

STEP 23

PARTS REQUIRED

12 - DRAWER BOTTOM x1

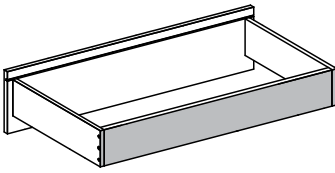

HARDWARE REQUIRED

K  06

TOOLS REQUIRED

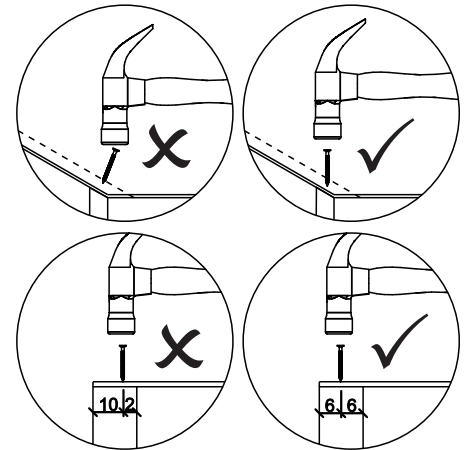
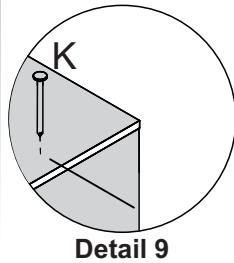
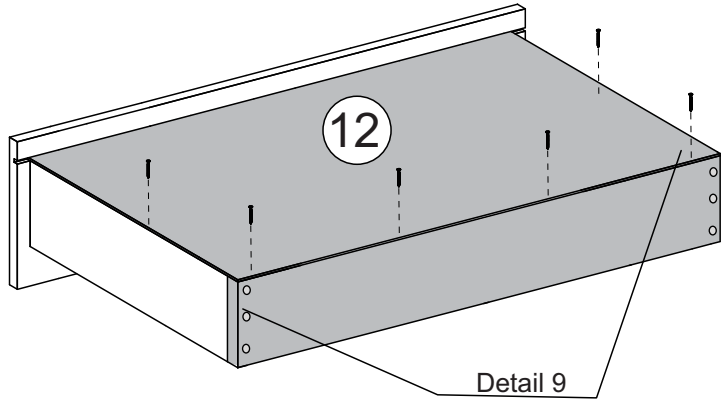
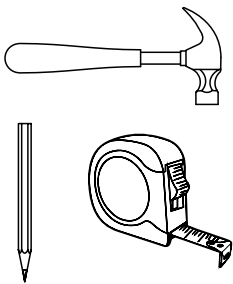

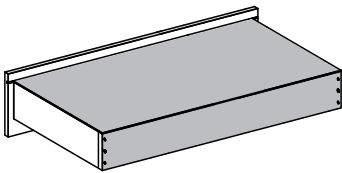

STEP 24

PARTS REQUIRED



HARDWARE REQUIRED

A  04
Ø3,0 x 12mm

J  01
LEFT

J  01
RIGHT

TOOLS REQUIRED

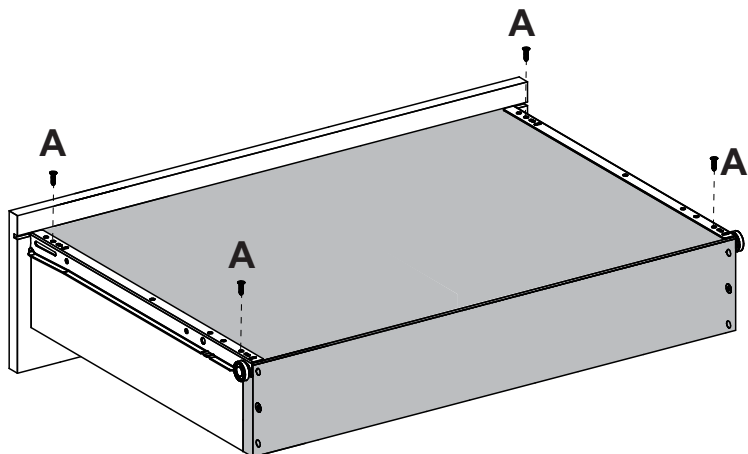
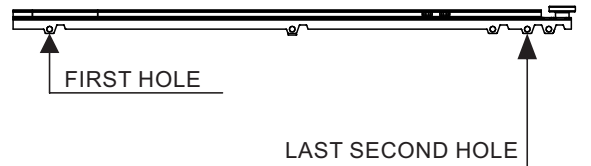
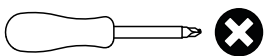

STEP 25

PARTS REQUIRED

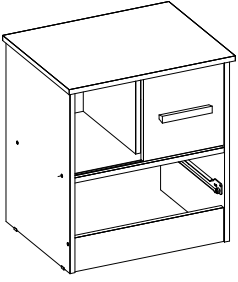

HARDWARE REQUIRED

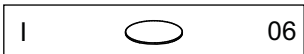
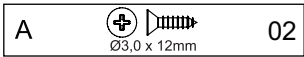

TOOLS REQUIRED

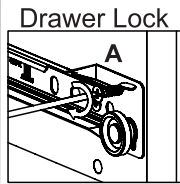
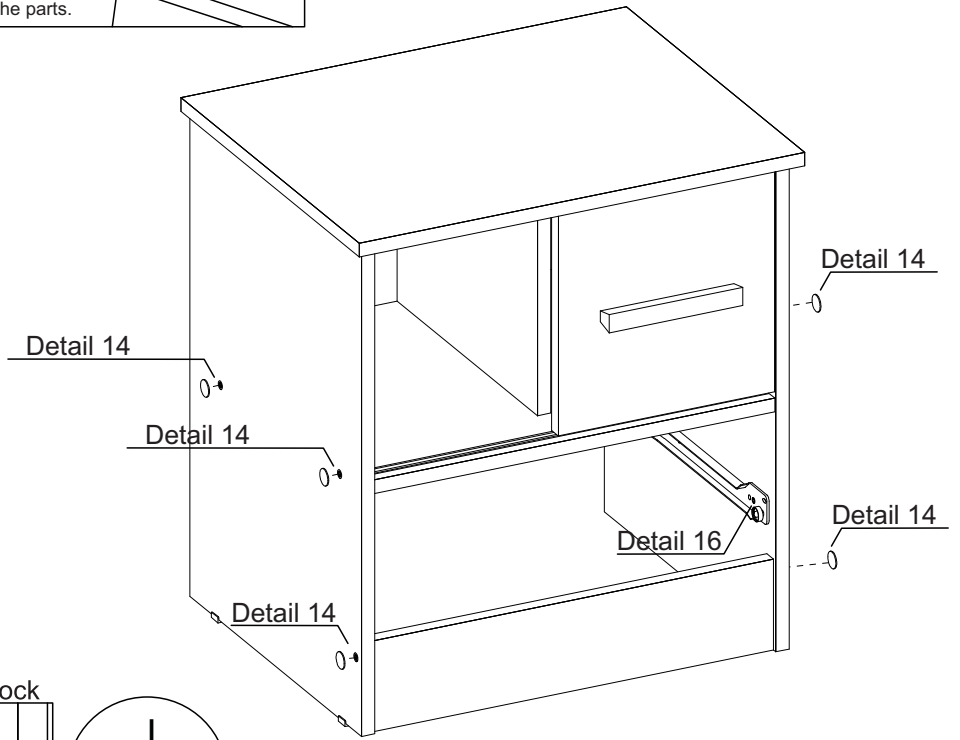
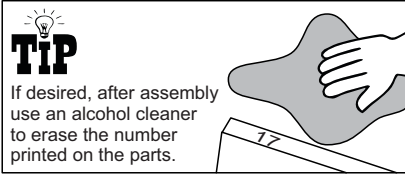
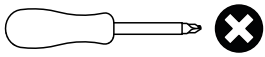

Detail 16

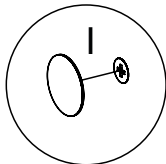

Detail 14

STEP 26

PARTS REQUIRED

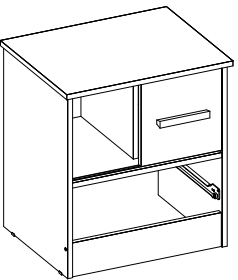

HARDWARE REQUIRED

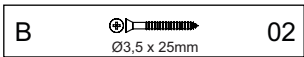

TOOLS REQUIRED

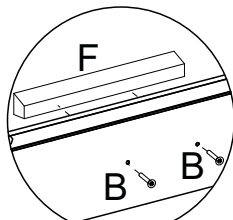
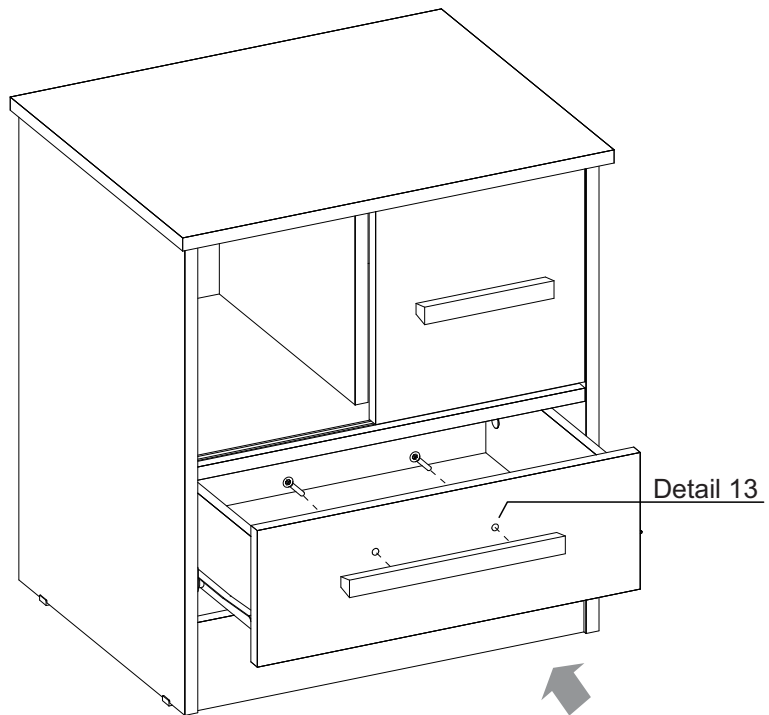
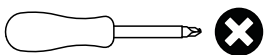

Detail 13