

# GREY/CHARCOAL CONCRETE EFFECT NORDIC 3 DRAWER BEDSIDE ASSEMBLY INSTRUCTIONS

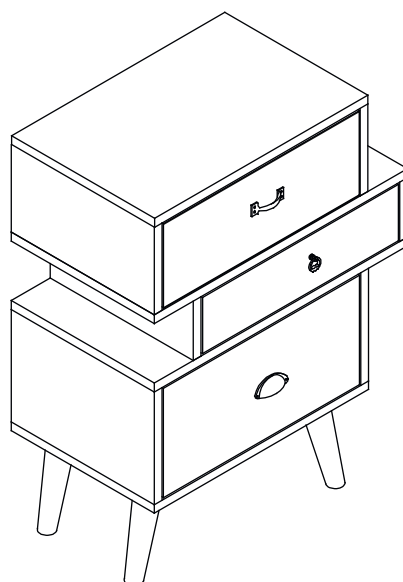

## FOR DOMESTIC USE ONLY IMPORTANT

### PLEASE READ BEFORE YOU CONTINUE FURTHER

THE PRODUCT YOU HAVE PURCHASED WILL GIVE YOU MANY YEARS OF SERVICE IF YOU FOLLOW THE GUIDELINES FOR ITS SAFE ASSEMBLY AND PERIODIC MAINTENANCE AND CLEANING.

ASSEMBLE ON A SOFT CLEAN SURFACE.

DO NOT USE ANY TOOLS OTHER THAN THOSE SHOWN.

ANY SPANNERS OR ALLEN KEYS REQUIRED ARE INCLUDED WITH THE FITTING KIT.

DO NOT FOR ANY REASON USE A POWER TOOL TO ASSEMBLE THIS PRODUCT. ITS USE WILL INVALIDATE ANY CLAIM YOU MAY HAVE AND COULD MAKE THIS PRODUCT UNSAFE.

DEPENDING ON THE AMOUNT OF USE THIS PRODUCT RECEIVES, IT MAY BE NECESSARY TO TIGHTEN UP THE FIXINGS FROM TIME TO TIME. THIS IS COMPLETELY NORMAL FOR ANY FLAT PACK FURNITURE. DO NOT OVERTIGHTEN FIXINGS.

FOR CLEANING, YOU MAY USE A DAMP CLOTH (NOT WET). DO NOT USE POLISH, DETERGENT OR CHEMICAL CLEANERS.

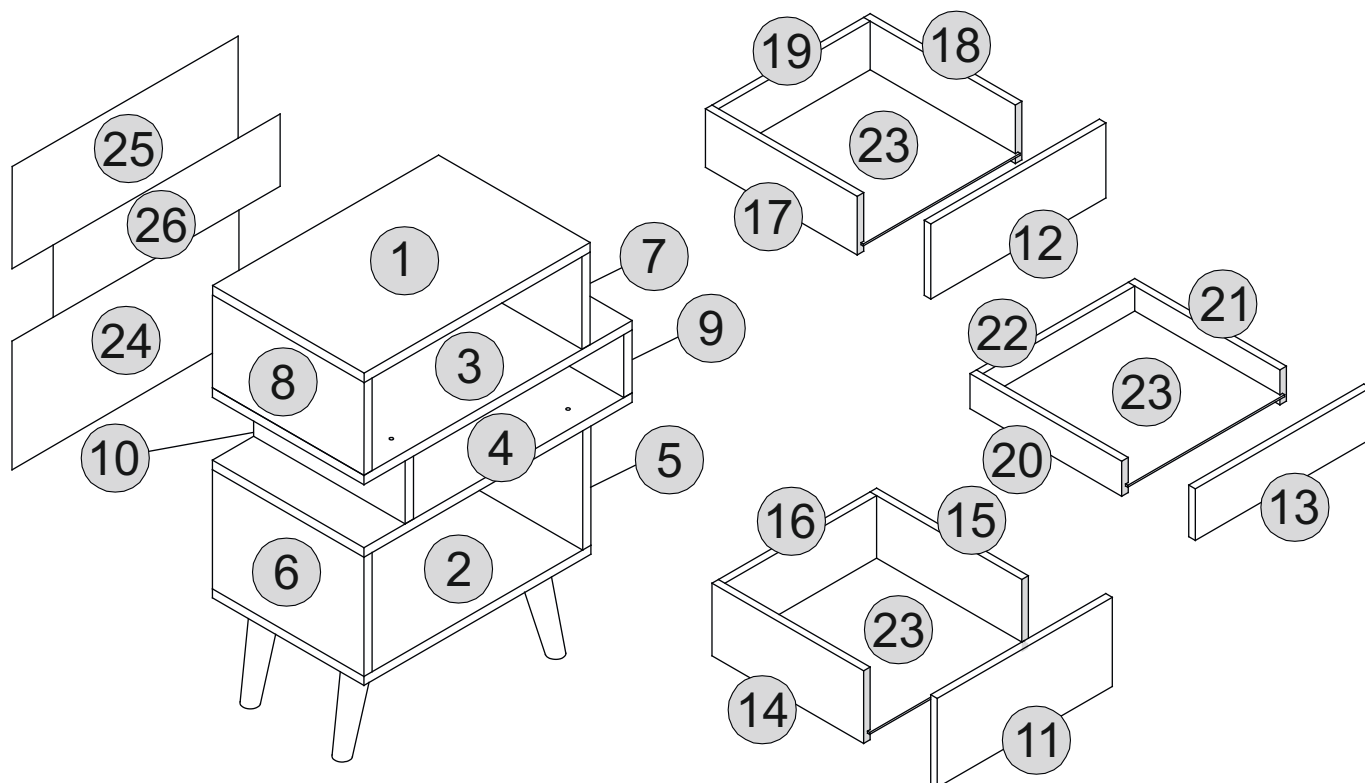

THIS SURFACE OF THIS ITEM IS NOT HEAT RESISTANT. ALWAYS USE A PLACE MAT UNDER HOT OR COLD ITEMS TO PREVENT MARKING.



## PART LIST

Part Number	Part Code	Part Description	Quantity	Carton
1	S100-103-086-TA1-01	Top Panel	1	1/1
2	S100-103-086-TA1-02	Bottom Panel	1	1/1
3	S100-103-086-TA1-03	Shelf Panel	1	1/1
4	S100-103-086-TA1-04	Shelf Panel	1	1/1
5	S100-103-086-TA1-05	Right Bottom Side Panel	1	1/1
6	S100-103-086-TA1-06	Left Bottom Side Panel	1	1/1
7	S100-103-086-TA1-07	Right Top Side Panel	1	1/1
8	S100-103-086-TA1-08	Left Top Side Panel	1	1/1
9	S100-103-086-TA1-09	Right Centre Side Panel	1	1/1
10	S100-103-086-TA1-10	Left Centre Side Panel	1	1/1
11	S100-103-086-TA1-11	Bottom Drawer Front	1	1/1
12	S100-103-086-TA1-12	Top Drawer Front	1	1/1
13	S100-103-086-TA1-13	Centre Drawer Front	1	1/1
14	S100-103-086-TA1-14	Left Bottom Drawer Side	1	1/1
15	S100-103-086-TA1-15	Right Bottom Drawer Side	1	1/1
16	S100-103-086-TA1-16	Bottom Drawer Back	1	1/1
17	S100-103-086-TA1-17	Left Top Drawer Side	1	1/1
18	S100-103-086-TA1-18	Right Top Drawer Side	1	1/1
19	S100-103-086-TA1-19	Top Drawer Back	1	1/1
20	S100-103-086-TA1-20	Left Centre Drawer Side	1	1/1
21	S100-103-086-TA1-21	Right Centre Drawer Side	1	1/1
22	S100-103-086-TA1-22	Centre Drawer Back	1	1/1
23	S100-103-086-TA1-23	Drawer Base	3	1/1
24	S100-103-086-TA1-24	Bottom Back Panel	1	1/1
25	S100-103-086-TA1-25	Top Back Panel	1	1/1
26	S100-103-086-TA1-26	Centre Back Panel	1	1/1

# HARDWARE LIST

No.	Part Name		Qty
A	Wooden Dowel (6x30mm)		x34
B	45mm Screw (4x45mm)		x16
C	16mm Screw (3.5x14mm)		x40
D	38mm Screw (4x38mm)		x12
E	Cam Bolt (8032T)		x14
F	Cam Nut (1510)		x14
G	Wood Leg + Plastic Foot		x4
H	6/8" Nail		x34
I	14" Drawer Slide		x3
J	Handle+Screw 1pc(M4x20mm)		x1
K	Handle+Screw 4pc(M3x16mm)		x1
L	Handle+Screw 2pc(M3x16mm)		x1

## TIPS FOR FITTINGS CAM-LOCKS

WHEN FITTING CAM NUT. ENSURE STARTING POSITION IS CORRECT BEFORE YOU INSERT CONNECTING CAM BOLT TURN CLOCKWISE UNTIL SECURE

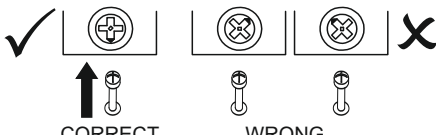

**CORRECT**      **WRONG**

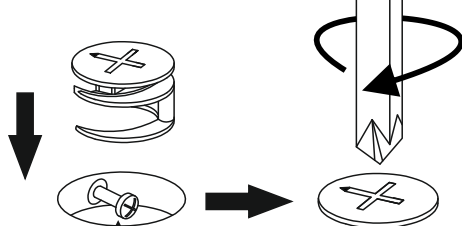

Cam bolt head needs to be in centre

### CAMBOLT

Tighten until shoulder in flush with panel. Do not overtighten or undertighten (see example below)

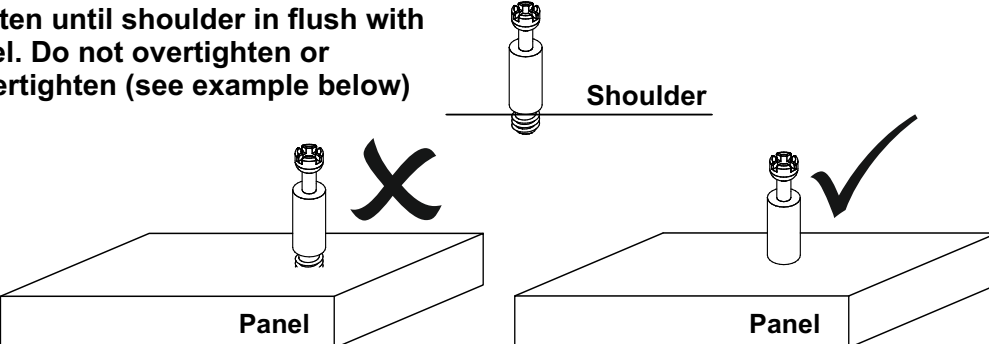

**Panel**      **Panel**

Shoulder

# STEP 1

## PARTS REQUIRED

1 - TOP PANEL	x1
3 - SHELF PANEL	x1
4 - SHELF PANEL	x1

## HARDWARE REQUIRED

E		08
---	---	----

## TOOLS REQUIRED

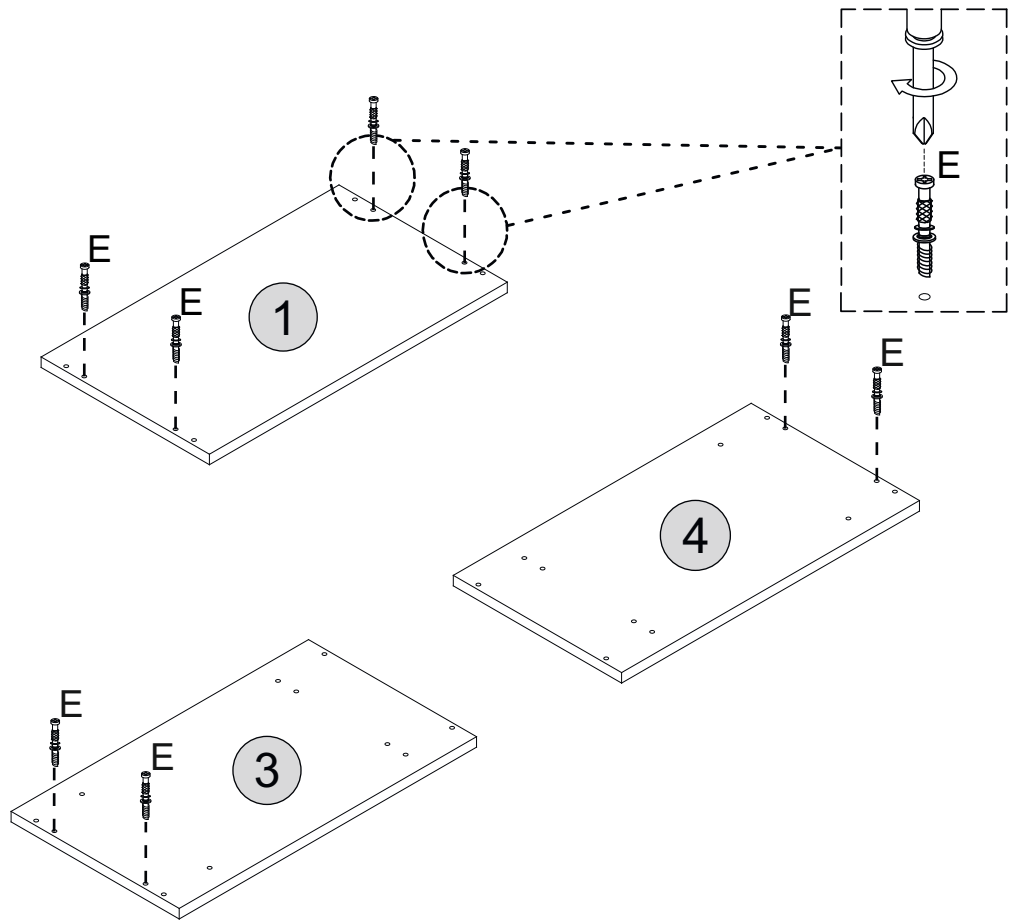
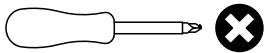

# STEP 2

## PARTS REQUIRED

5 - RIGHT BOTTOM SIDE PANEL	x1
6 - LEFT BOTTOM SIDE PANEL	x1

## HARDWARE REQUIRED

A		08
---	---	----

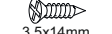
C		04
---	---	----

I		02
---	---	----

## TOOLS REQUIRED

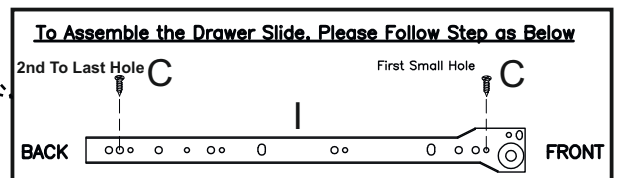
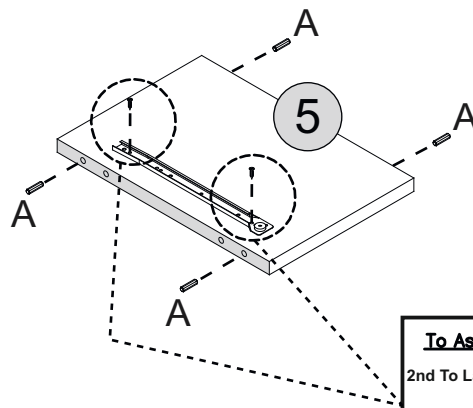
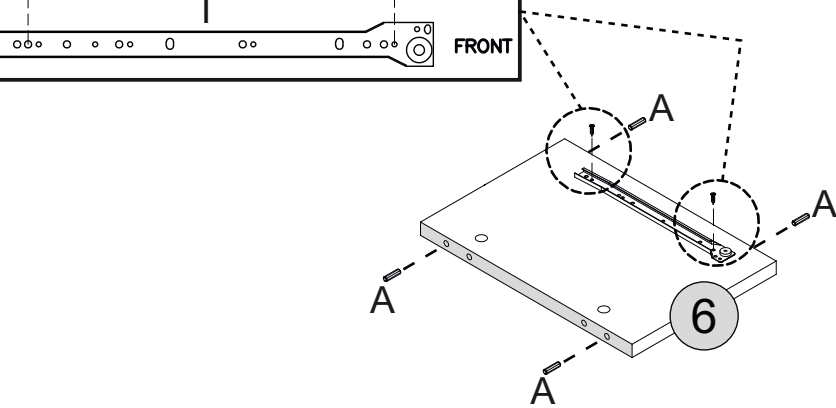
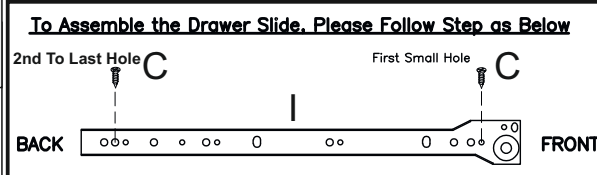
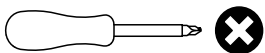

# STEP 3

## PARTS REQUIRED

7 - RIGHT TOP SIDE PANEL x1

8 - LEFT TOP SIDE PANEL x1

## HARDWARE REQUIRED

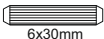
A  08

C  04

I  02

## TOOLS REQUIRED

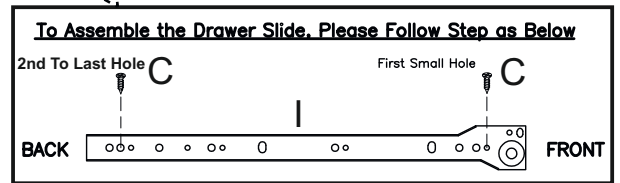
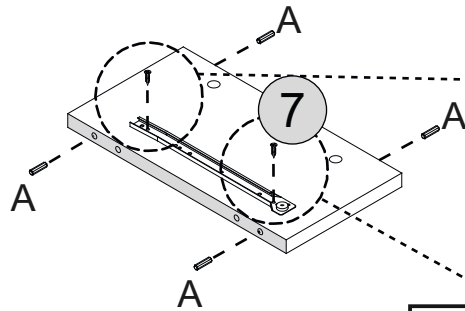
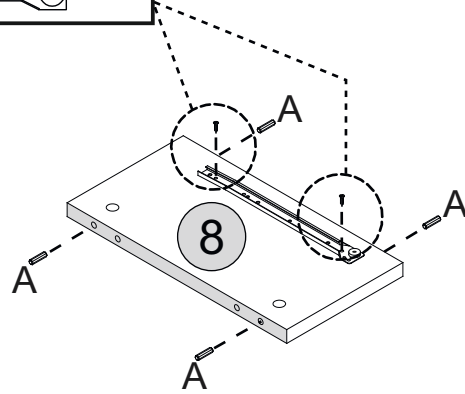
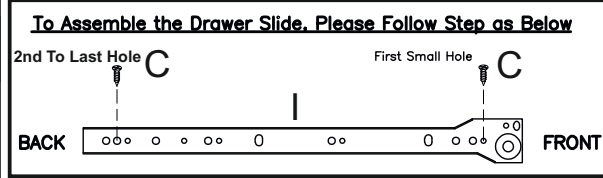
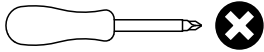

# STEP 4

## PARTS REQUIRED

9 - RIGHT CENTRE SIDE PANEL x1

10 - LEFT CENTRE SIDE PANEL x1

## HARDWARE REQUIRED

A  08

C  04

I  02

## TOOLS REQUIRED

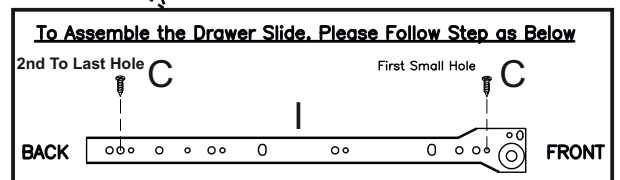
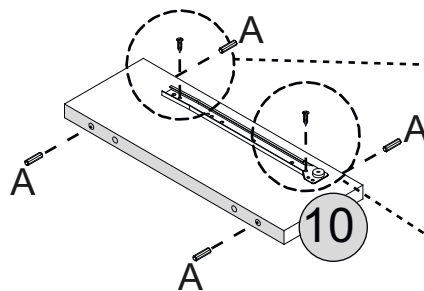
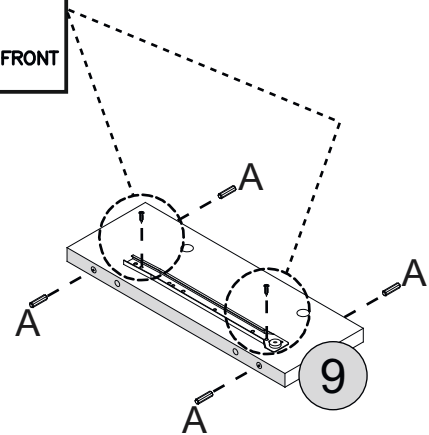
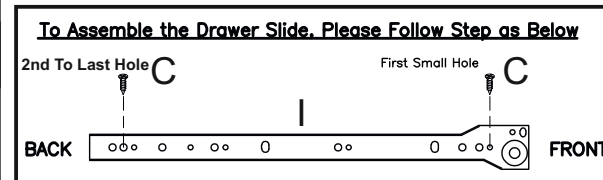
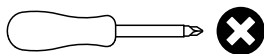

# STEP 5

## PARTS REQUIRED

6 - LEFT BOTTOM SIDE PANEL x1

7 - RIGHT TOP SIDE PANEL x1

8 - LEFT TOP SIDE PANEL x1

9 - RIGHT CENTRE SIDE PANEL x1

## HARDWARE REQUIRED

F  08

## TOOLS REQUIRED

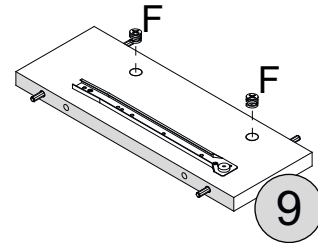
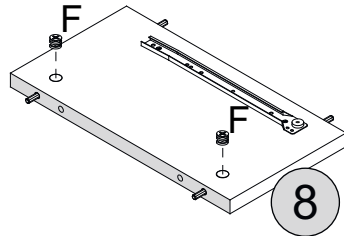
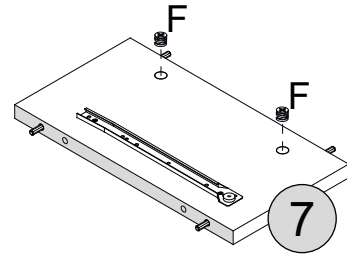
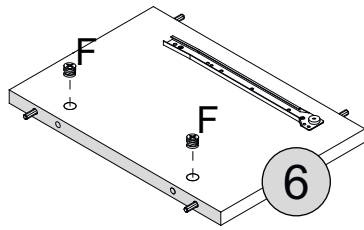
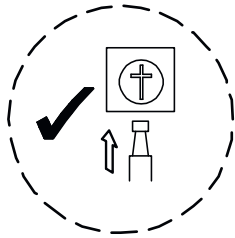

# STEP 6

## PARTS REQUIRED

3 - SHELF PANEL x1

9 - RIGHT CENTRE SIDE PANEL x1

10 - LEFT CENTRE SIDE PANEL x1

## HARDWARE REQUIRED

B  02  
4x45mm

## TOOLS REQUIRED

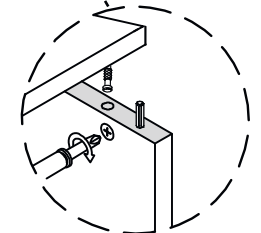
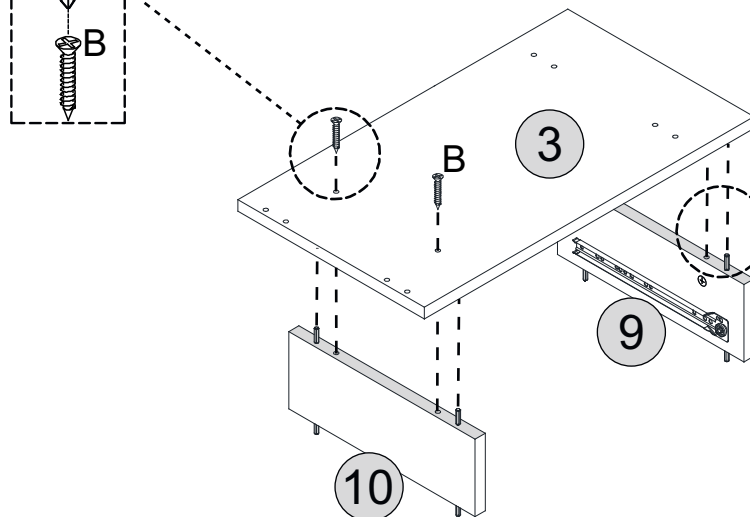
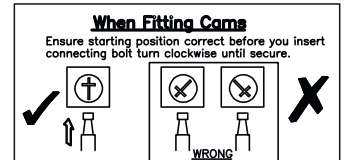
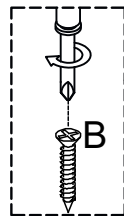
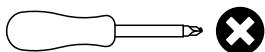

# STEP 7

## PARTS REQUIRED

7 - RIGHT TOP SIDE PANEL x1

8 - LEFT TOP SIDE PANEL x1

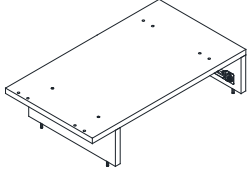

## HARDWARE REQUIRED

B  04

## TOOLS REQUIRED

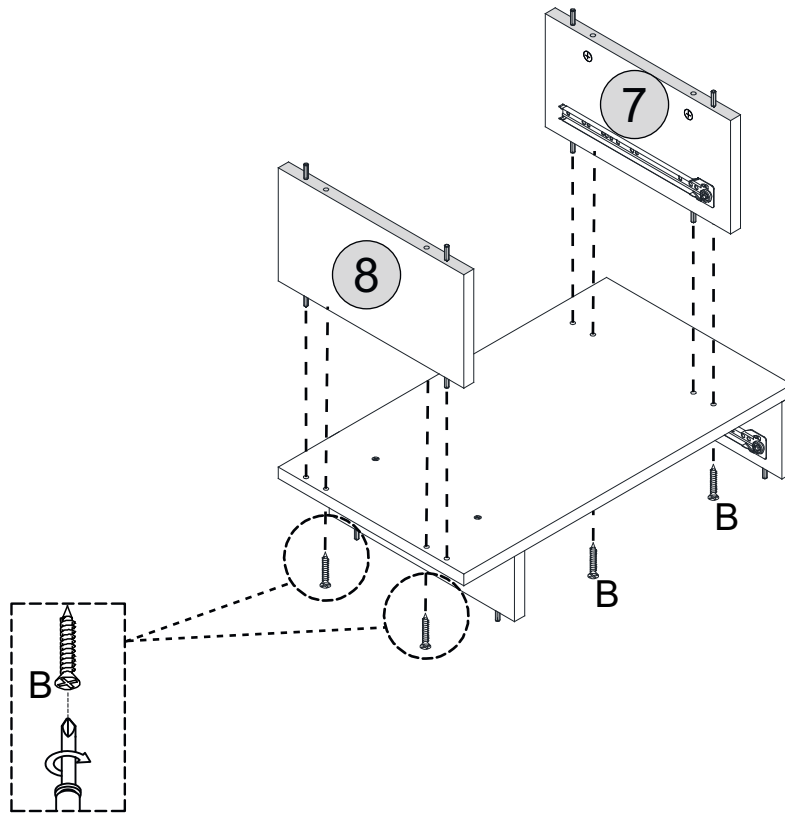
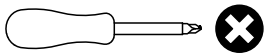

# STEP 8

## PARTS REQUIRED

4 - SHELF PANEL x1

5 - RIGHT BOTTOM SIDE PANEL x1

6 - LEFT BOTTOM SIDE PANEL x1

## HARDWARE REQUIRED

B  02

## TOOLS REQUIRED

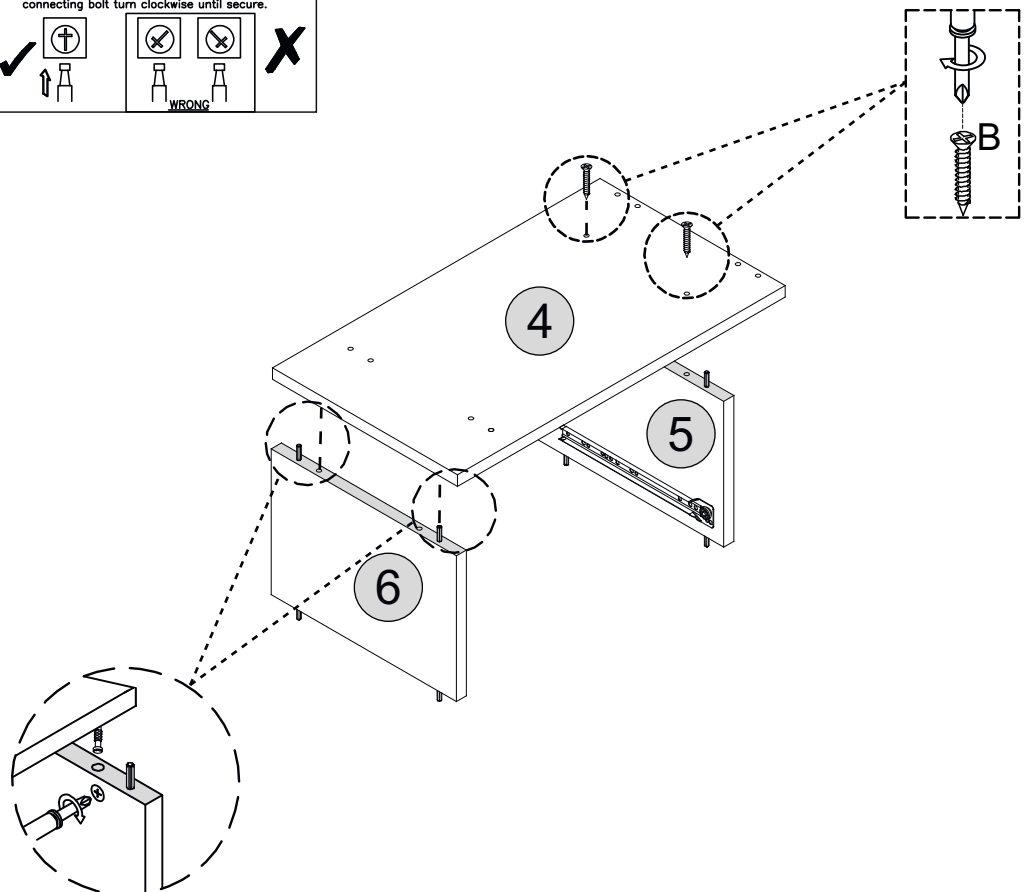
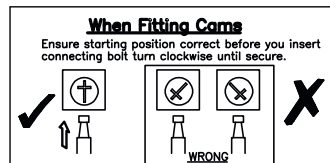
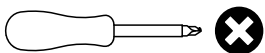

# STEP 9

**PARTS REQUIRED**

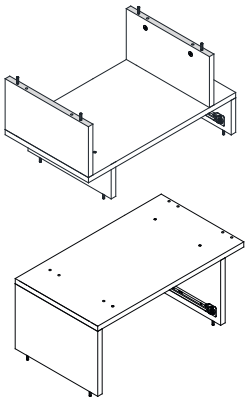

**HARDWARE REQUIRED**

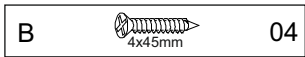

**TOOLS REQUIRED**

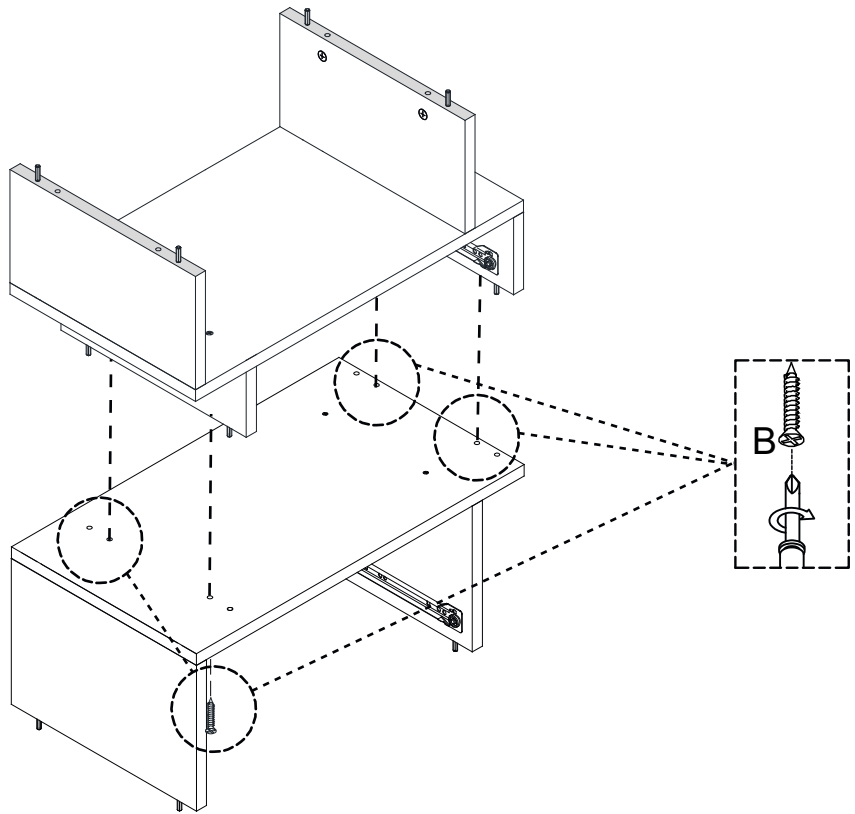
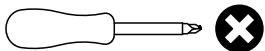

# STEP 10

**PARTS REQUIRED**

1 - TOP PANEL x1

2 - BOTTOM PANEL x1

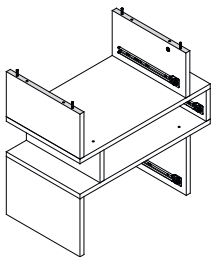

**HARDWARE REQUIRED**

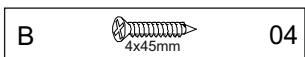

**TOOLS REQUIRED**

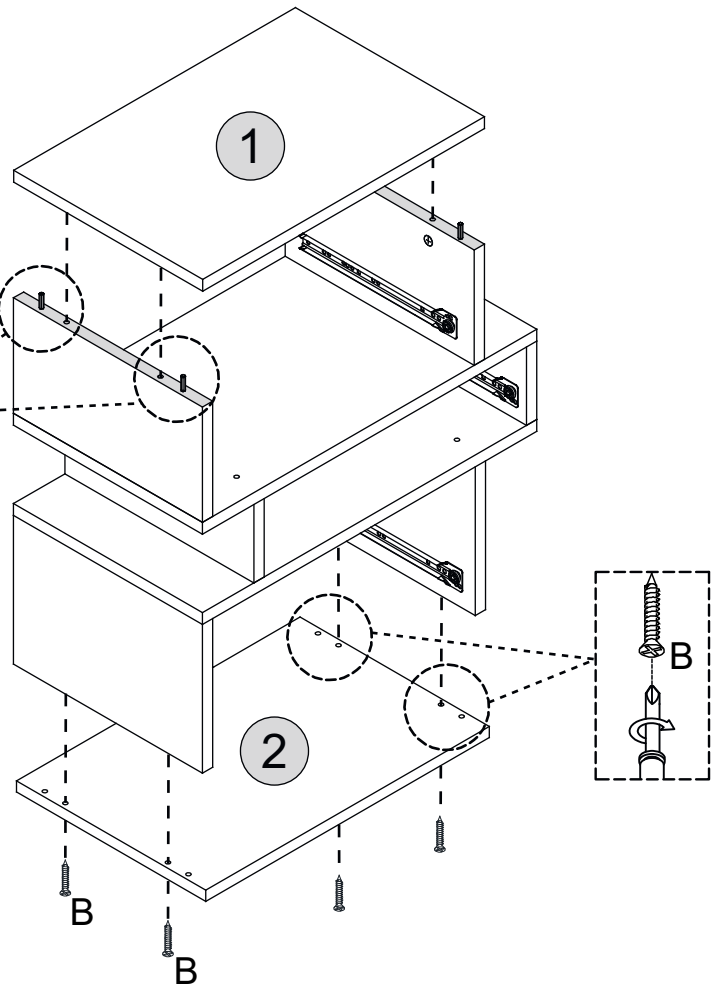
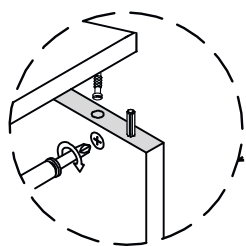
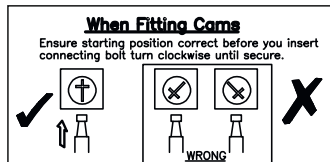
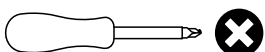



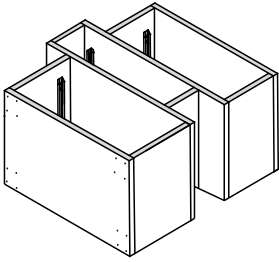

# STEP 11

**PARTS REQUIRED**



**HARDWARE REQUIRED**

C	 3.5x14mm	16
G		04

**TOOLS REQUIRED**

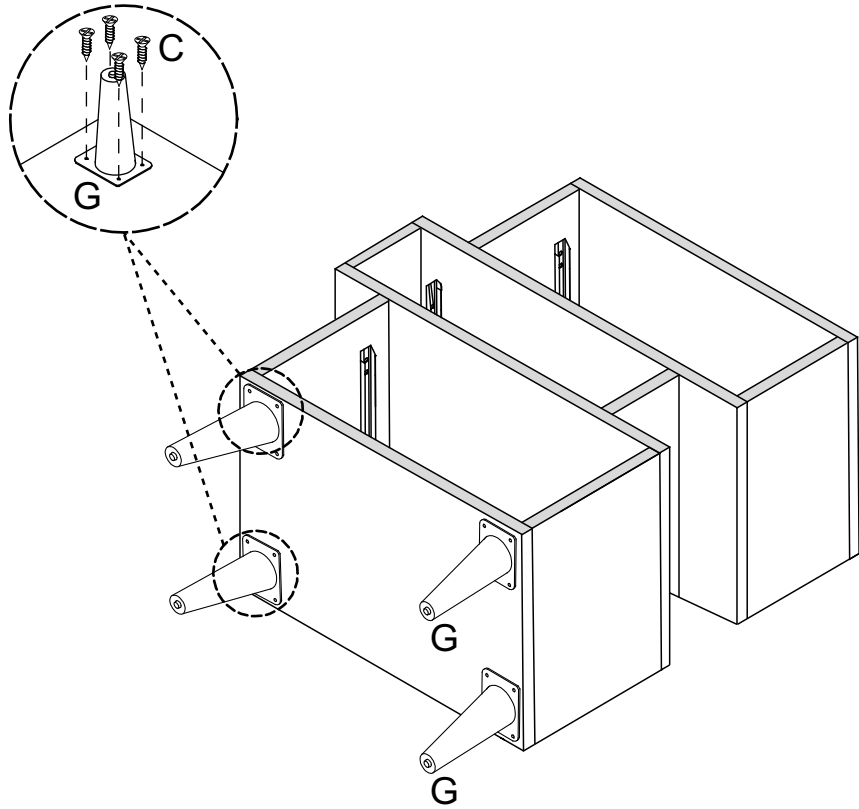
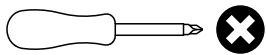

# STEP 12

**PARTS REQUIRED**

24 - BOTTOM BACK PANEL	x1
25 - TOP BACK PANEL	x1
26 - CENTRE BACK PANEL	x1

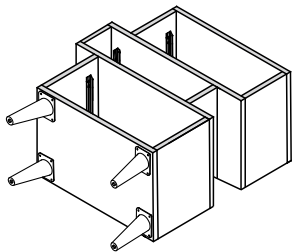

**HARDWARE REQUIRED**

H		34
---	---	----

**TOOLS REQUIRED**

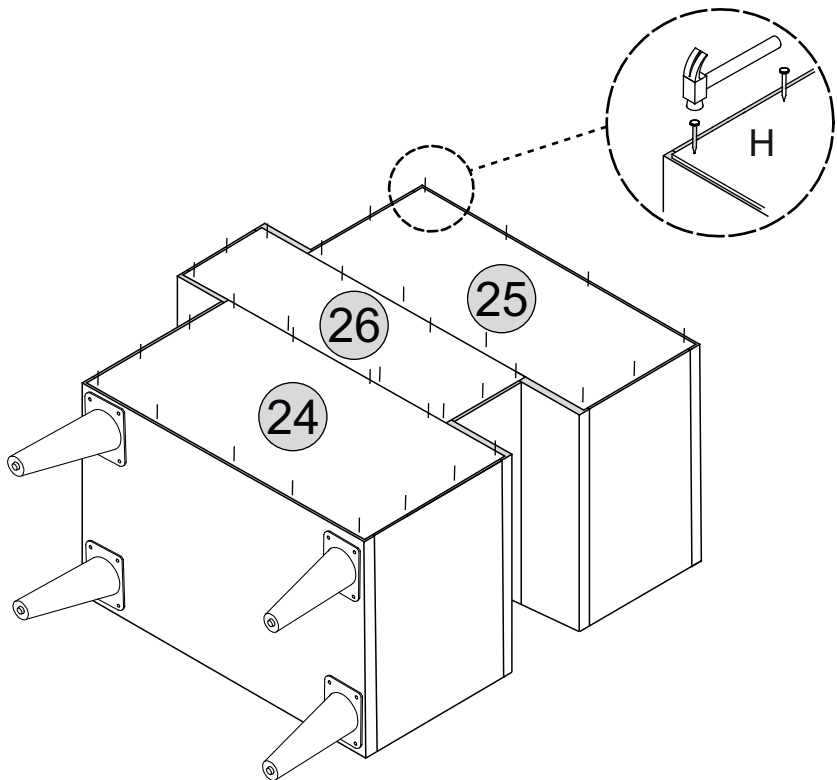
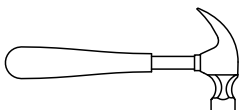

# STEP 13

## PARTS REQUIRED

11 - BOTTOM DRAWER FRONT x1

14 - LEFT BOTTOM DRAWER SIDE x1

15 - RIGHT BOTTOM DRAWER SIDE x1

## HARDWARE REQUIRED

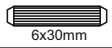
A  04

E  02

F  02

## TOOLS REQUIRED

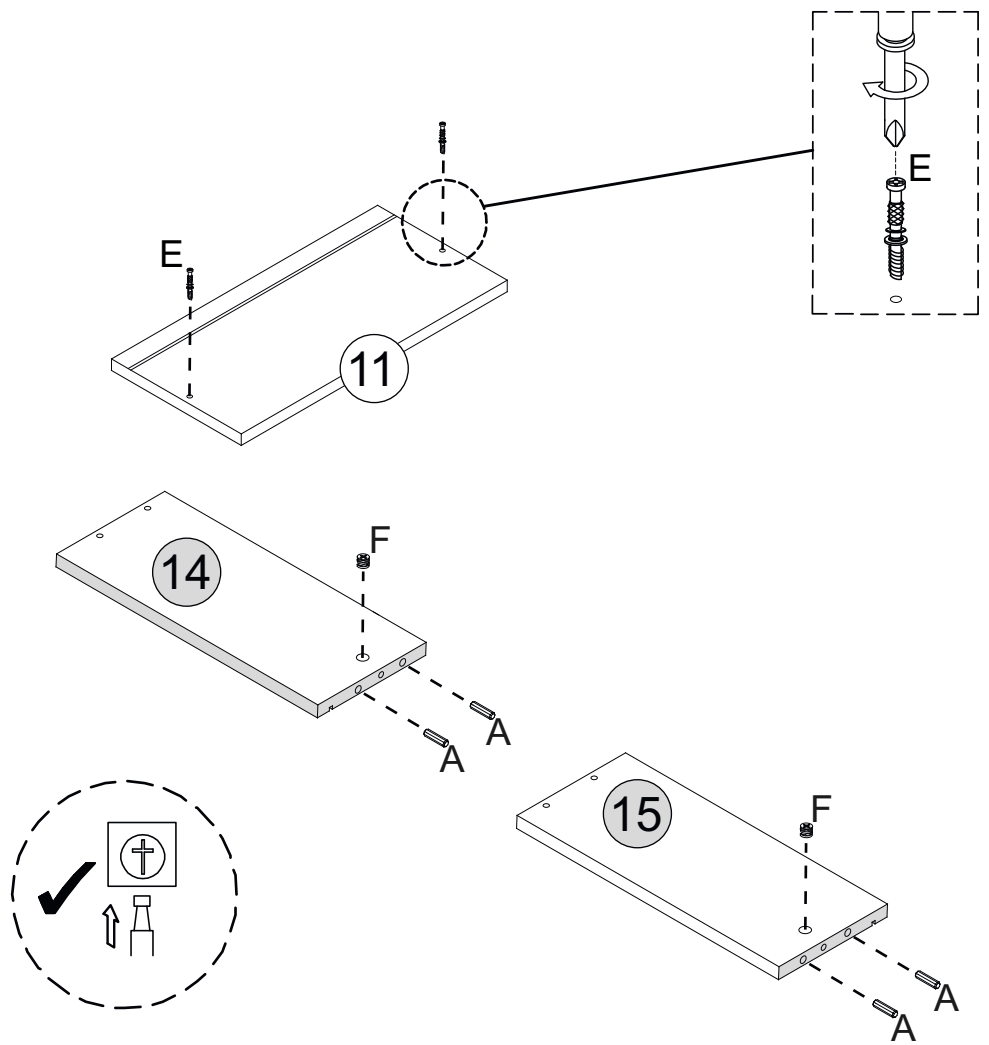
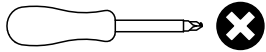

# STEP 14

## PARTS REQUIRED

11 - BOTTOM DRAWER FRONT x1

14 - LEFT BOTTOM DRAWER SIDE x1

15 - RIGHT BOTTOM DRAWER SIDE x1

16 - BOTTOM DRAWER BACK x1

23 - DRAWER BASE x1

## HARDWARE REQUIRED

D  04

## TOOLS REQUIRED

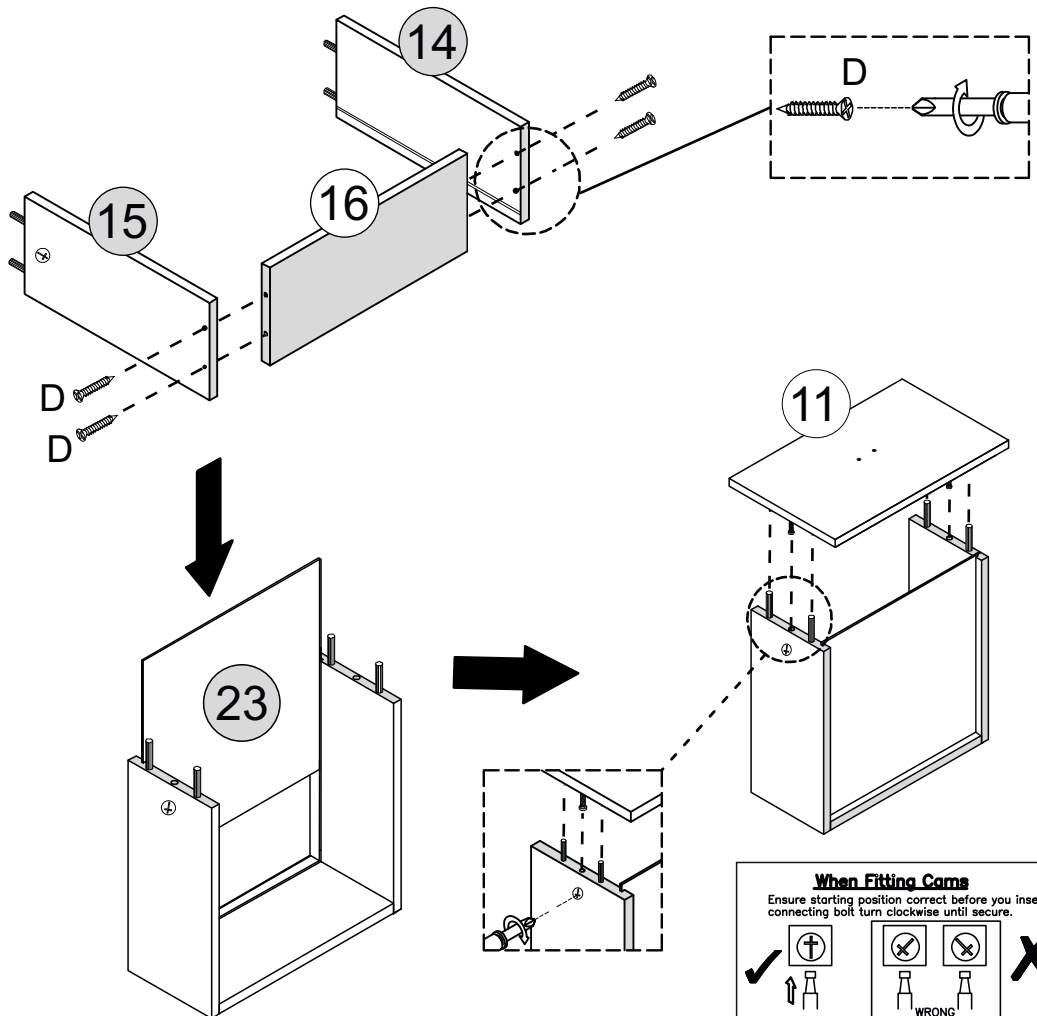
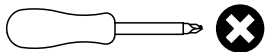

# STEP 15

## PARTS REQUIRED

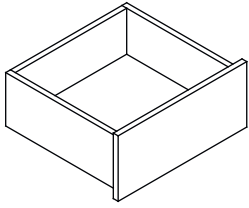

## HARDWARE REQUIRED

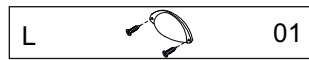
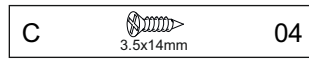

## TOOLS REQUIRED

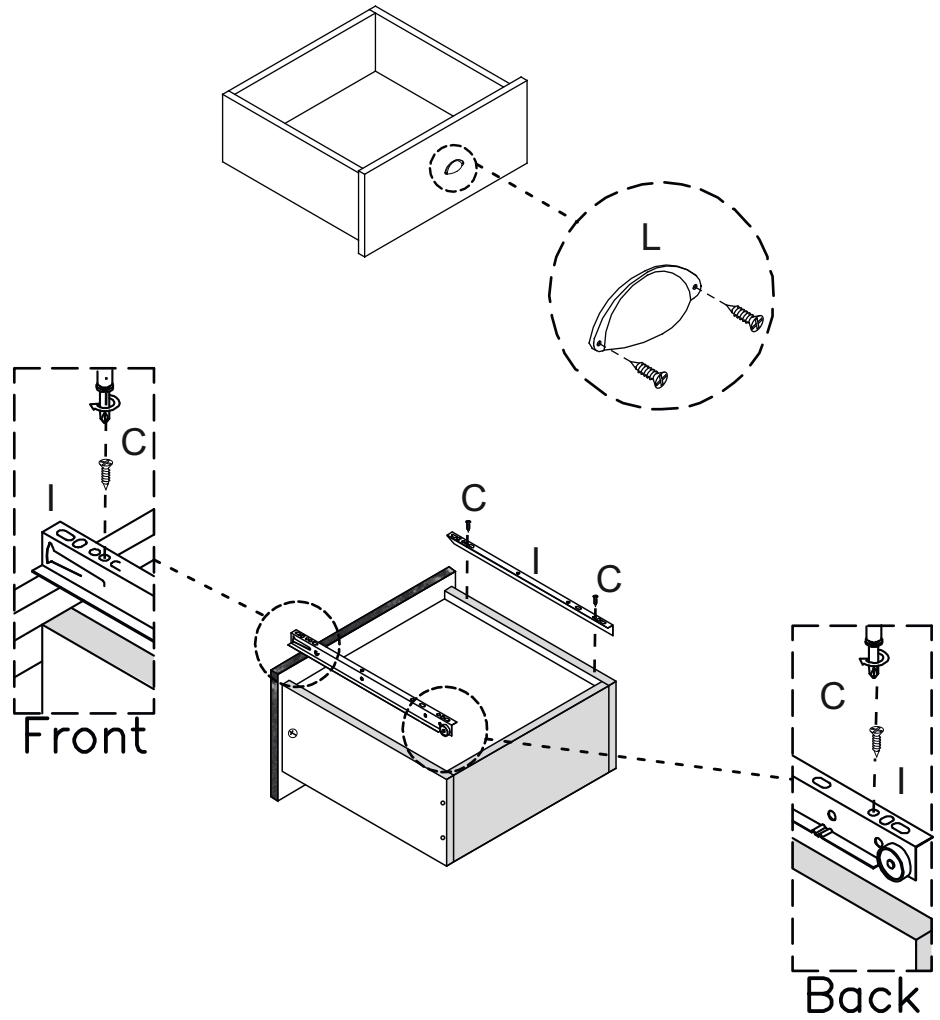
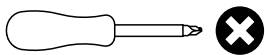

# STEP 16

## PARTS REQUIRED



## HARDWARE REQUIRED

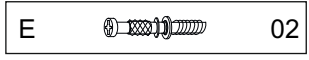
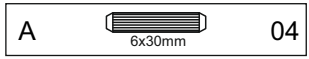

## TOOLS REQUIRED

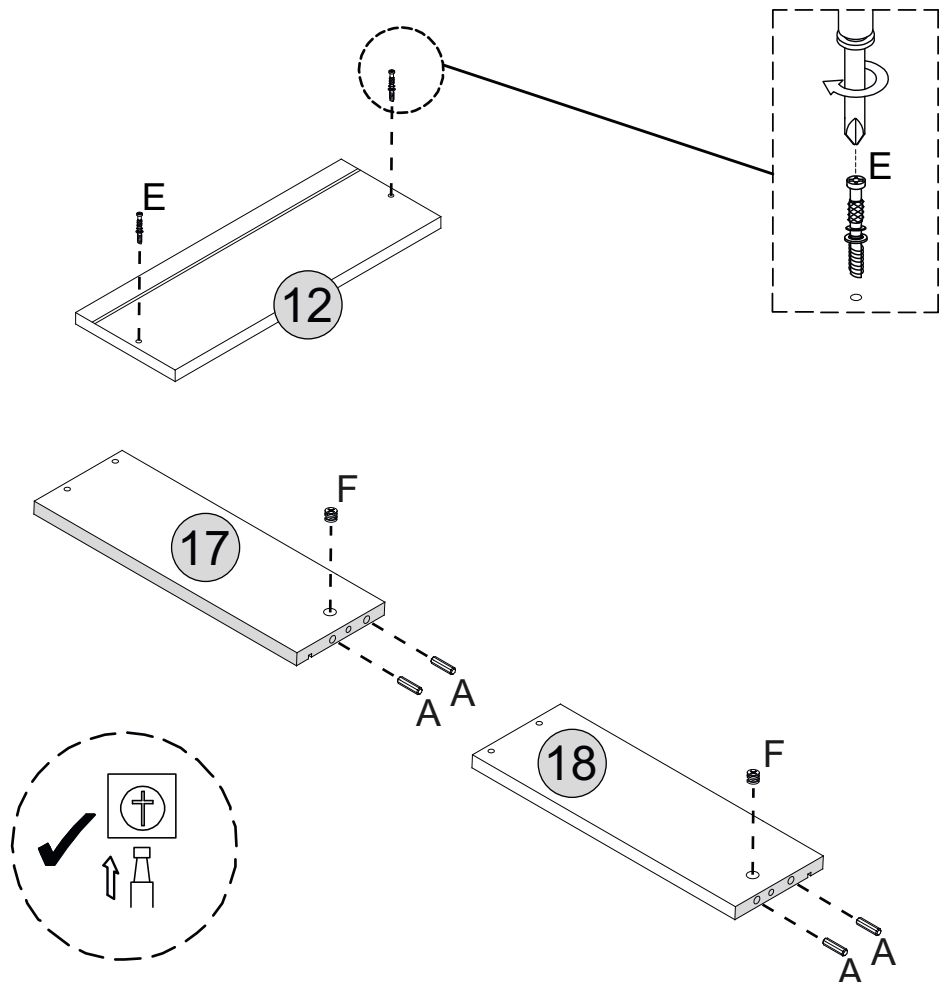
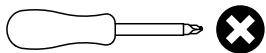

# STEP 17

## PARTS REQUIRED

12 - TOP DRAWER FRONT	x1
17 - LEFT TOP DRAWER SIDE	x1
18 - RIGHT TOP DRAWER SIDE	x1
19 - TOP DRAWER BACK	x1
23 - DRAWER BASE	x1

## HARDWARE REQUIRED

D		04
---	---	----

## TOOLS REQUIRED

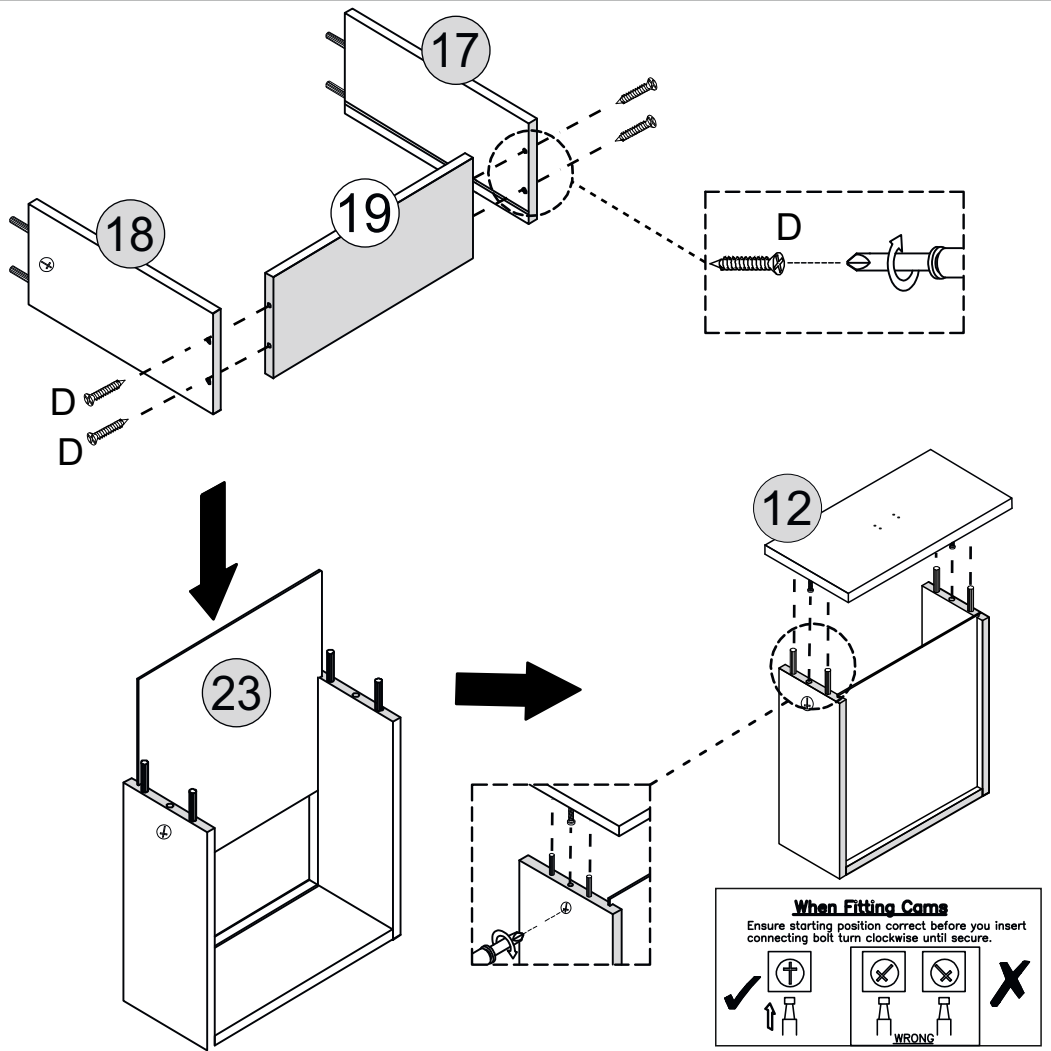
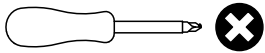

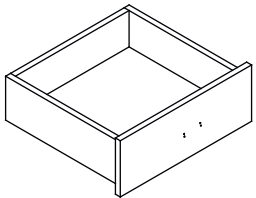

# STEP 18

## PARTS REQUIRED



## HARDWARE REQUIRED

C		04
I		01
K		01

## TOOLS REQUIRED

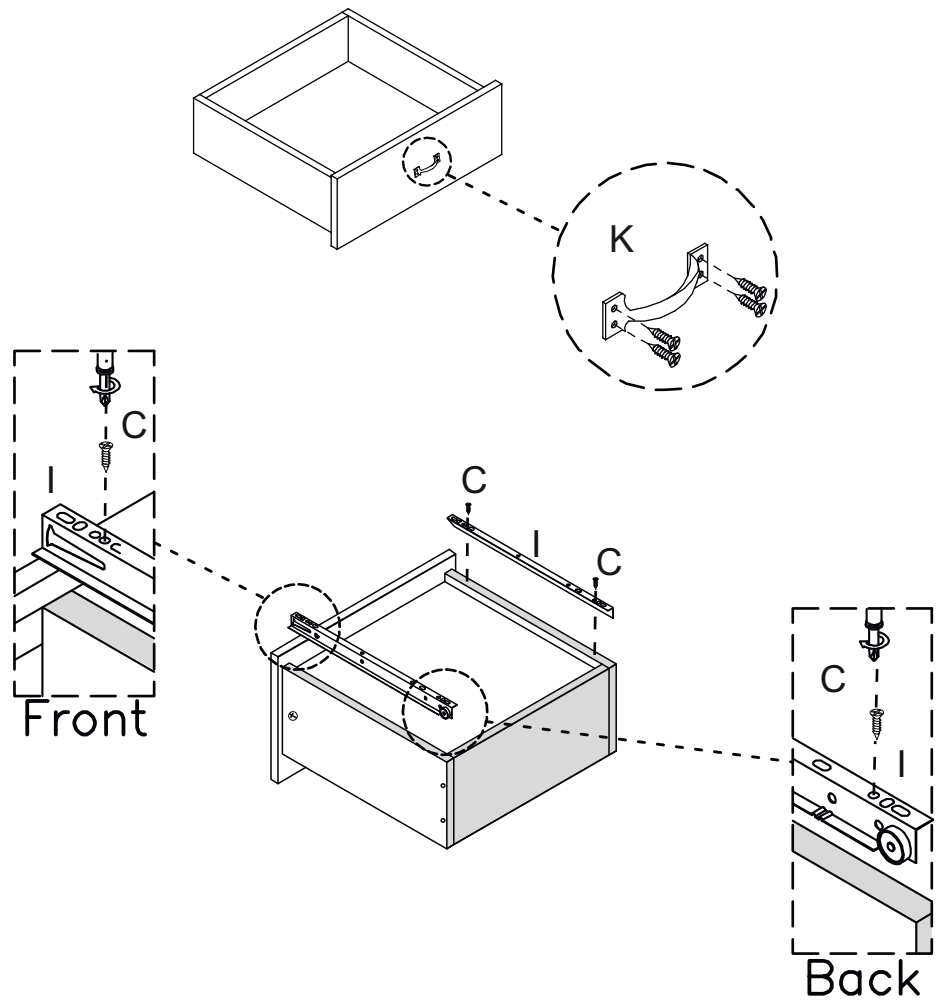
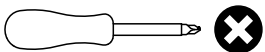

# STEP 19

## PARTS REQUIRED

13 - CENTRE DRAWER FRONT x1

20 - LEFT CENTRE DRAWER SIDE x1

21 - RIGHT CENTRE DRAWER SIDE x1

## HARDWARE REQUIRED

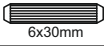
A  6x30mm 02

E  02

F  02

## TOOLS REQUIRED

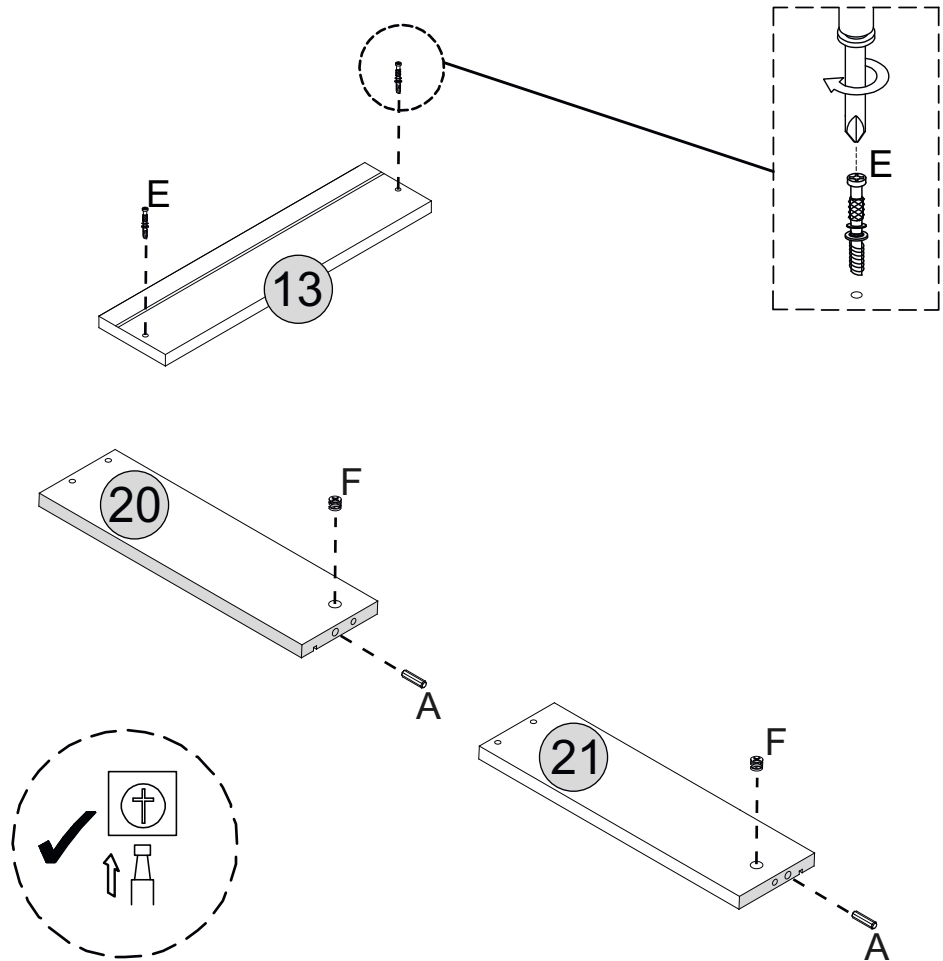
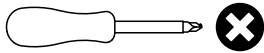

# STEP 20

## PARTS REQUIRED

13 - CENTRE DRAWER FRONT x1

20 - LEFT CENTRE DRAWER SIDE x1

21 - RIGHT CENTRE DRAWER SIDE x1

22 - CENTRE DRAWER BACK x1

23 - DRAWER BASE x1

## HARDWARE REQUIRED

D  4x38mm 04

## TOOLS REQUIRED

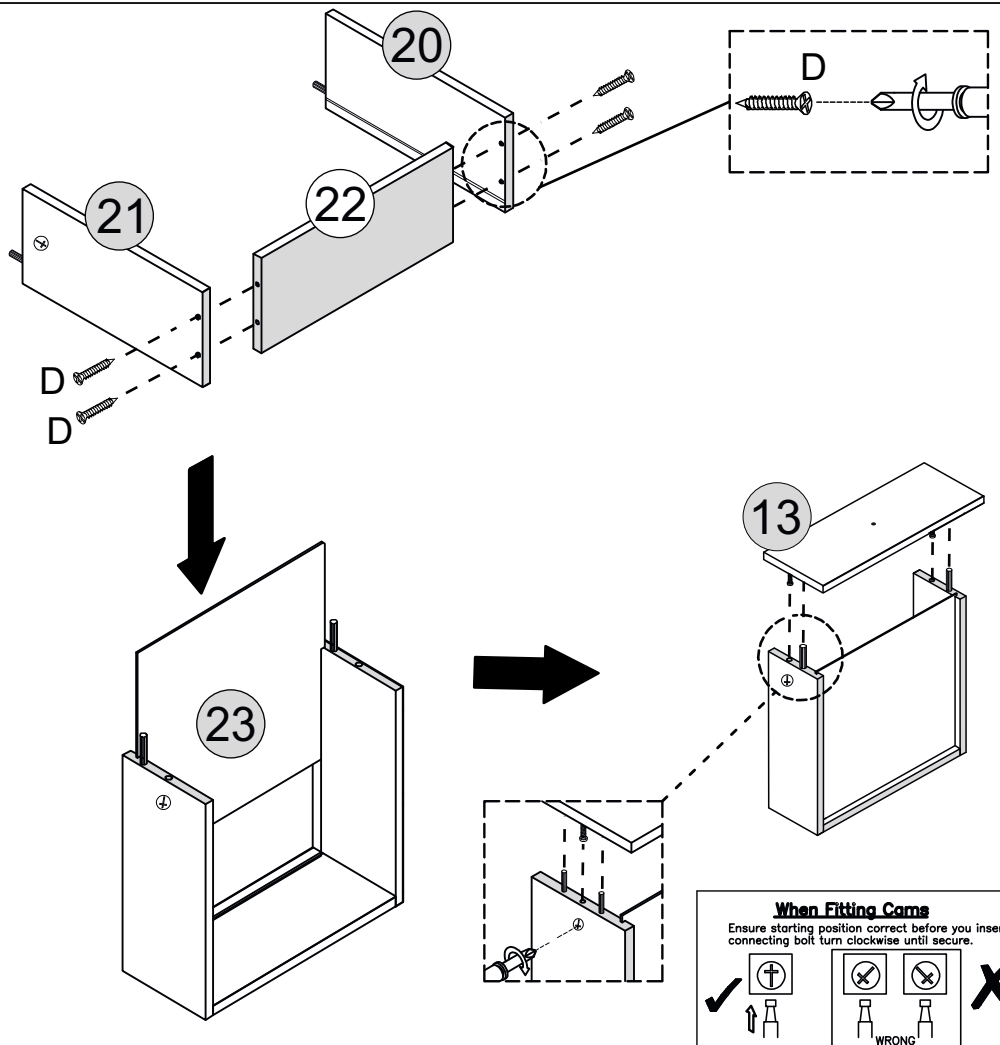
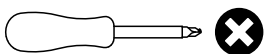

# STEP 21

## PARTS REQUIRED

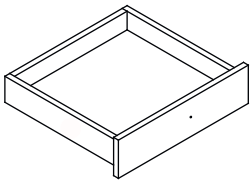

## HARDWARE REQUIRED

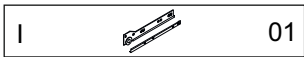
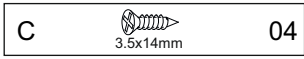

## TOOLS REQUIRED

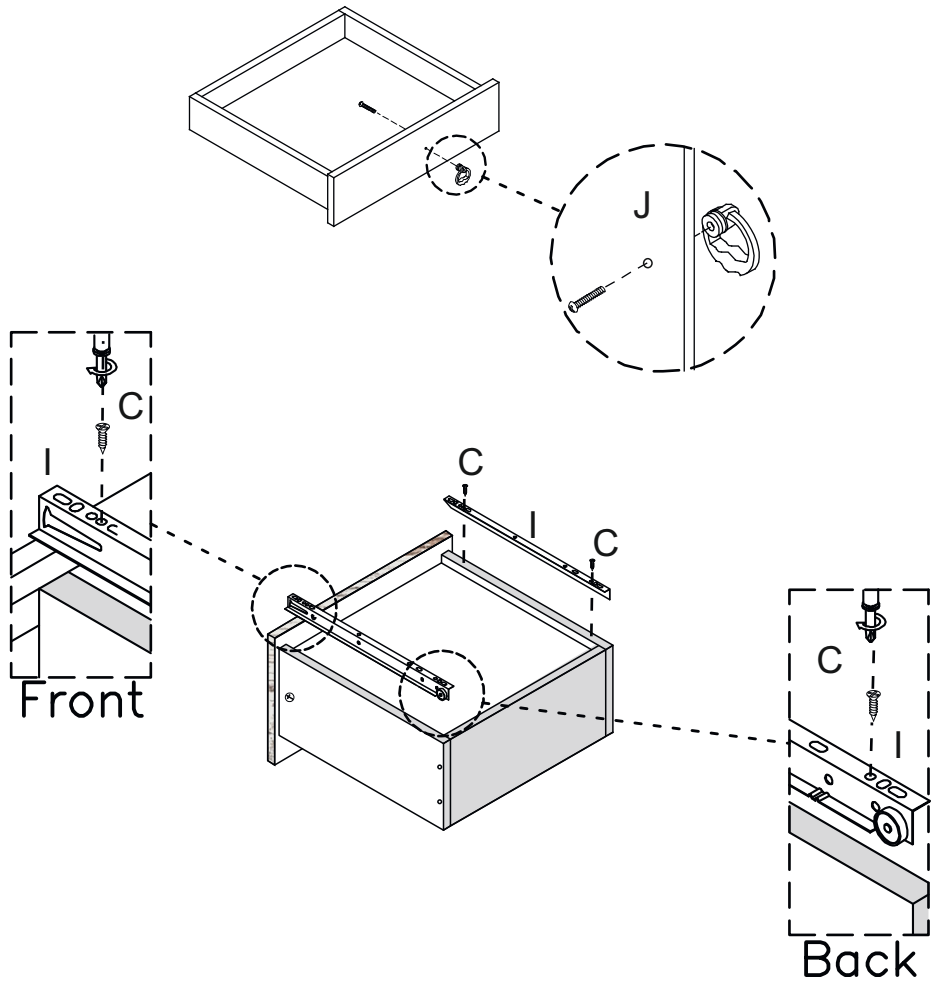
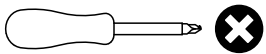

# STEP 22

## PARTS REQUIRED

