

FELIX 2 DOOR WARDROBE ASSEMBLY INSTRUCTIONS

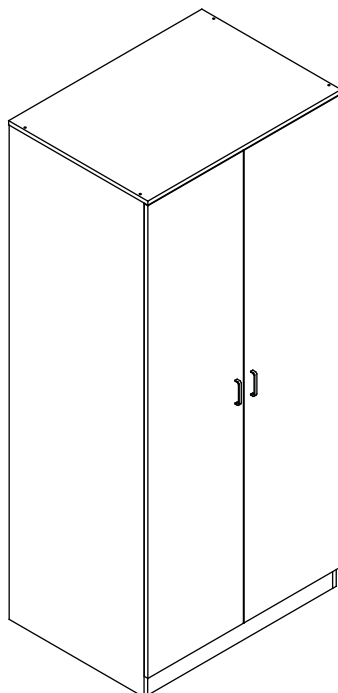

FOR DOMESTIC USE ONLY
IMPORTANT

PLEASE READ BEFORE YOU CONTINUE FURTHER

THE PRODUCT YOU HAVE PURCHASED WILL GIVE YOU MANY YEARS OF SERVICE IF YOU FOLLOW THE GUIDELINES FOR ITS SAFE ASSEMBLY AND PERIODIC MAINTENANCE AND CLEANING
ASSEMBLE ON A SOFT CLEAN SURFACE

DO NOT USE ANY TOOLS OTHER THAN THOSE SHOWN

ANY SPANNERS OR ALLEN KEYS REQUIRED ARE INCLUDED WITH THE FITTING KIT.

DO NOT FOR ANY REASON USE A POWER TOOL TO ASSEMBLE THIS PRODUCT. ITS USE WILL INVALIDATE ANY CLAIM YOU MAY HAVE AND COULD MAKE THIS PRODUCT UNSAFE.

DEPENDING ON THE AMOUNT OF USE THIS PRODUCT RECEIVES, IT MAY BE NECESSARY TO TIGHTEN UP THE FIXINGS FROM TIME TO TIME. THIS IS COMPLETELY NORMAL FOR ANY FLAT PACK FURNITURE. DO NOT OVERTIGHTEN FIXINGS.





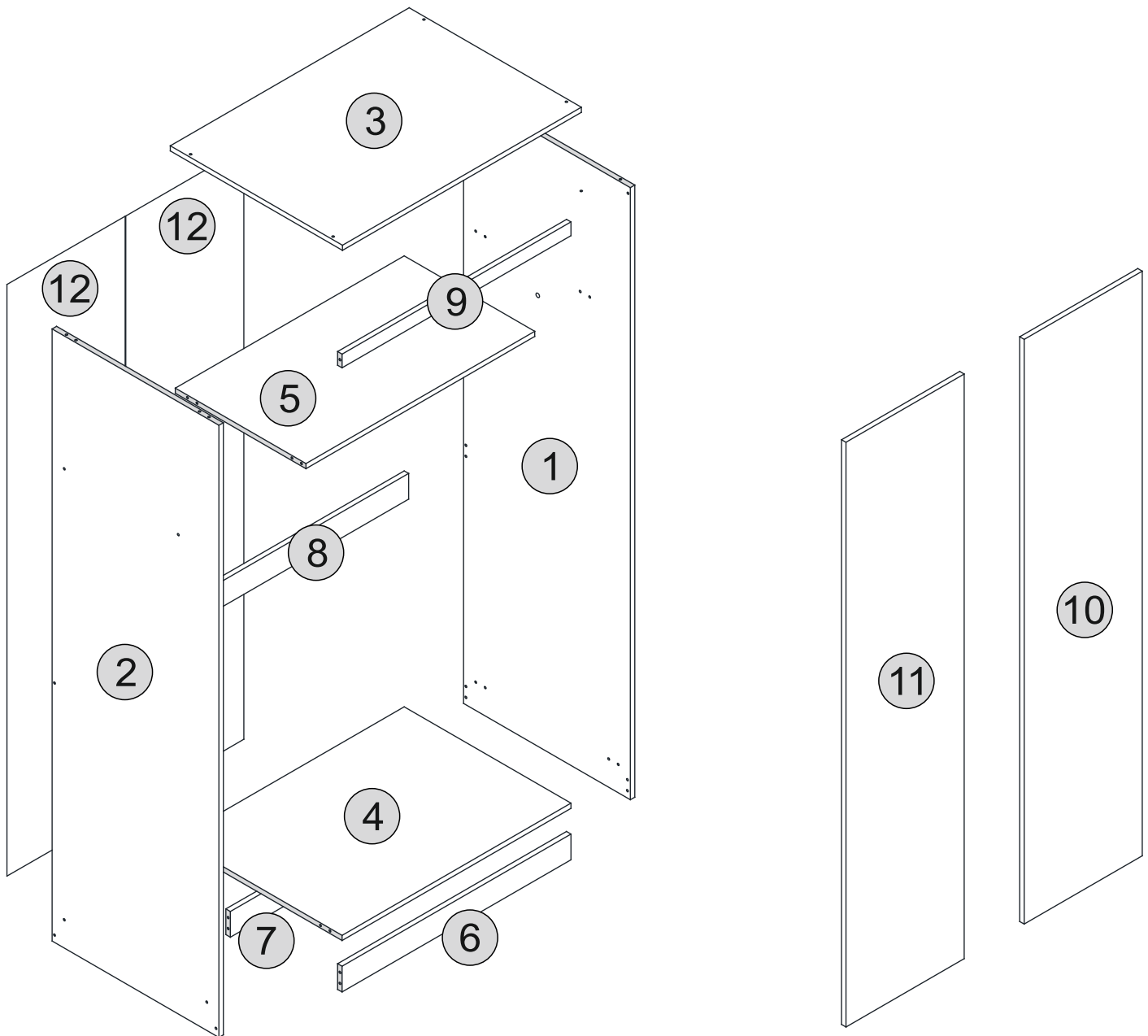





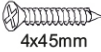

FOR CLEANING, YOU MAY USE A DAMP CLOTH (NOT WET). DO NOT USE POLISH, DETERGENT OR CHEMICAL CLEANERS.

THE SURFACE OF THIS ITEM IS NOT HEAT RESISTANT. ALWAYS USE A PLACE MAT UNDER HOT OR COLD ITEMS TO PREVENT MARKING.



Part Number	Part Code	Part Description	Quantity	Carton
1	S100-101-162-TA1-01	Right Side Panel	1	1/2
2	S100-101-162-TA1-02	Left Side Panel	1	1/2
3	S100-101-162-TA1-03	Top Panel	1	2/2
4	S100-101-162-TA1-04	Base	1	1/2
5	S100-101-162-TA1-05	Shelf	1	2/2
6	S100-101-162-TA1-06	Lower Front Crossbar	1	1/2
7	S100-101-162-TA1-07	Lower Back Crossbar	1	1/2
8	S100-101-162-TA1-08	Middle Back Crossbar	1	2/2
9	S100-101-162-TA1-09	Top Front Crossbar	1	2/2
10	S100-101-162-TA1-10	Right Door	1	2/2
11	S100-101-162-TA1-11	Left Door	1	2/2
12	S100-101-162-TA1-12	Back Panel	2	1/2

HARDWARE LIST

No.	Part Name		Qty
A	Wooden Dowel (6x25mm)		20
B	45mm Screw (4x45mm)		18
C	14mm Screw (3.5x14mm)		40
D	Hanging Rail (765mm)		1
E	5" Hinge		6
F	Hanging Rail Support		2
G	Handle (AL96mm)		2
H	Handle Screw		4
I	PVC L-Bracket		2
J	Plastic Foot		4
K	Nail		46
L	Screw Cover (Sticker 15mm)		14
M	Wall Fixings (4x20mm=1pc)		1

TIPS FOR FITTING CAM-LOCKS

WHEN FITTING THE CAM-LOCK
ENSURE STARTING POSITION IS CORRECT
BEFORE YOU INSERT CONNECTING CAM BOLT
TURN CLOCKWISE UNTIL SECURE

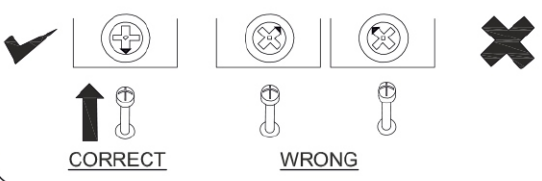

CORRECT **WRONG**

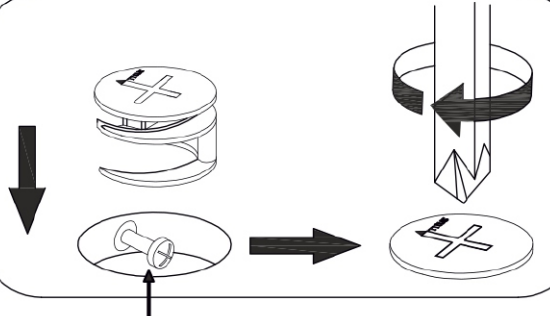

Cam bolt head needs to be in centre

CAMBOLT

Tighten until shoulder is flush with panel. Do not overtighten or undertighten (see example below)

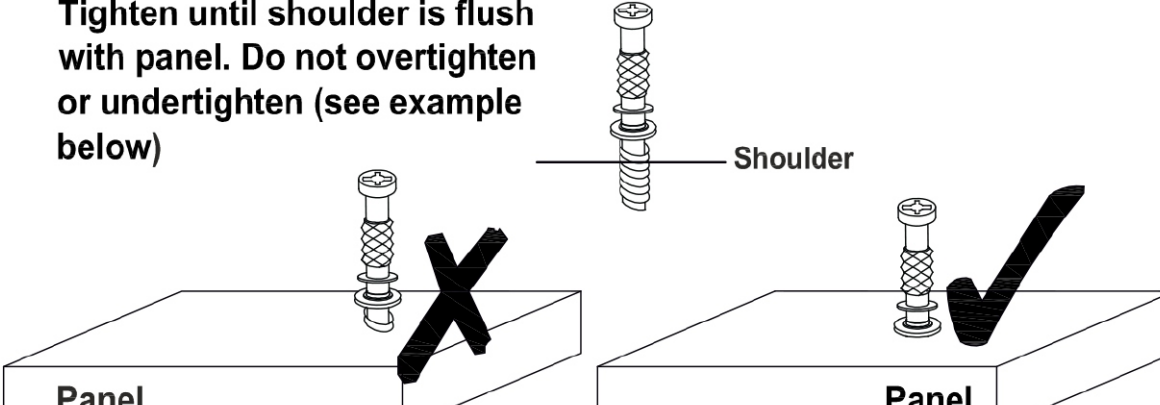

Shoulder

Panel

Panel

STEP 1

PARTS REQUIRED

- 4 - BASE x1
- 5 - SHELF x1
- 6 - LOWER FRONT CROSSBAR x1
- 7 - LOWER BACK CROSSBAR x1
- 8 - MIDDLE BACK CROSSBAR x1
- 9 - TOP FRONT CROSSBAR x1

HARDWARE REQUIRED

- A  16

TOOLS REQUIRED

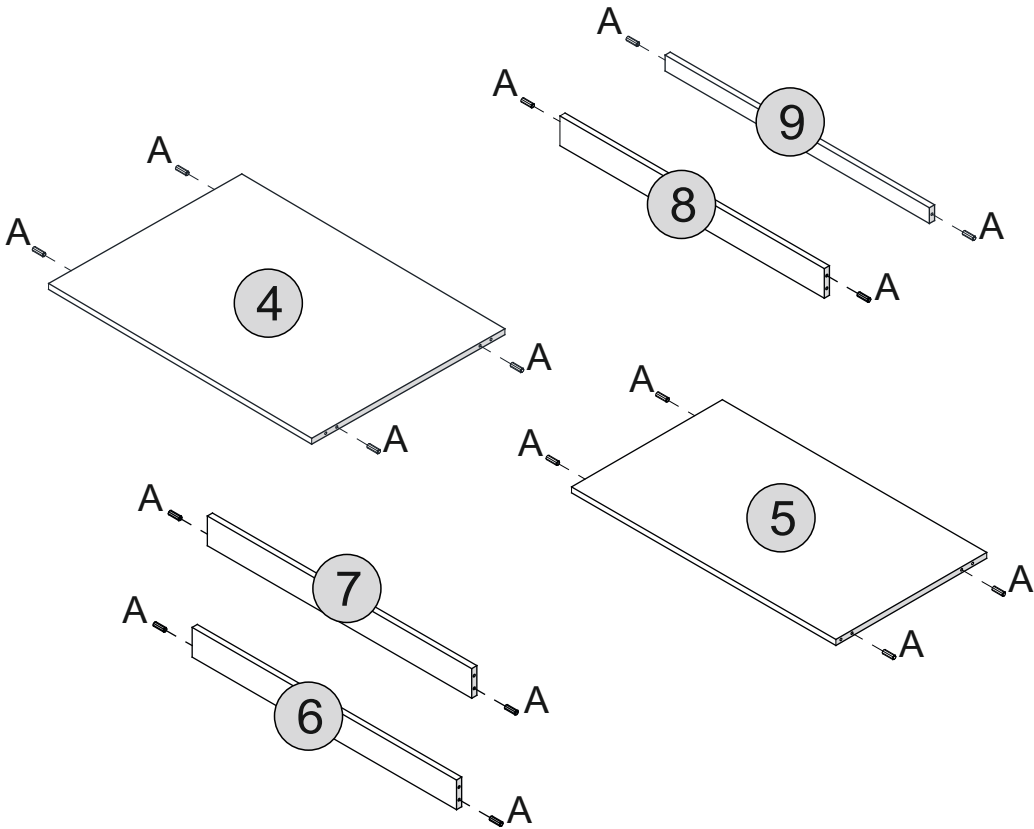
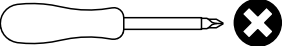





STEP 2

PARTS REQUIRED

- 1 - RIGHT SIDE PANEL x1
- 2 - LEFT SIDE PANEL x1

HARDWARE REQUIRED

- A  04
- C  04
- F  02
- J  04

TOOLS REQUIRED

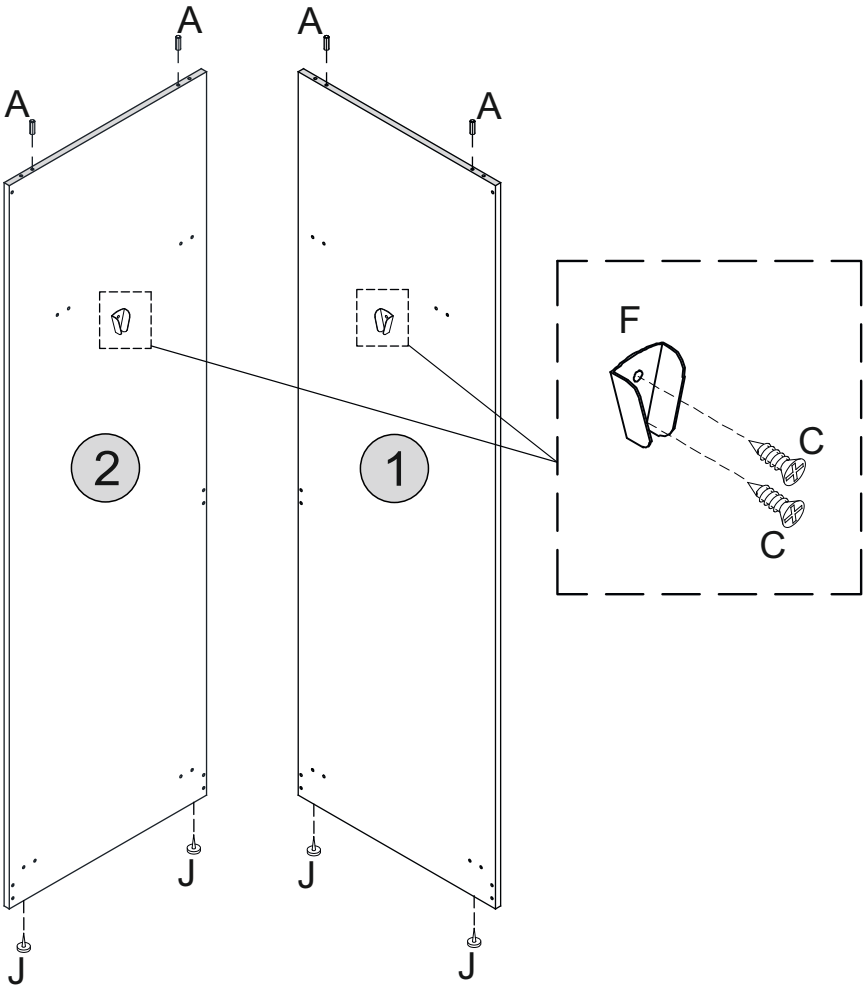
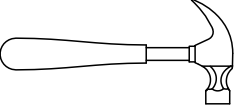
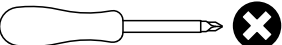



STEP 3

PARTS REQUIRED

- 2 - LEFT SIDE PANEL x1
- 4 - BASE x1
- 5 - SHELF x1
- 7 - LOWER BACK CROSSBAR x1
- 8 - MIDDLE BACK CROSSBAR x1

HARDWARE REQUIRED

- B  06
- L  06

TOOLS REQUIRED

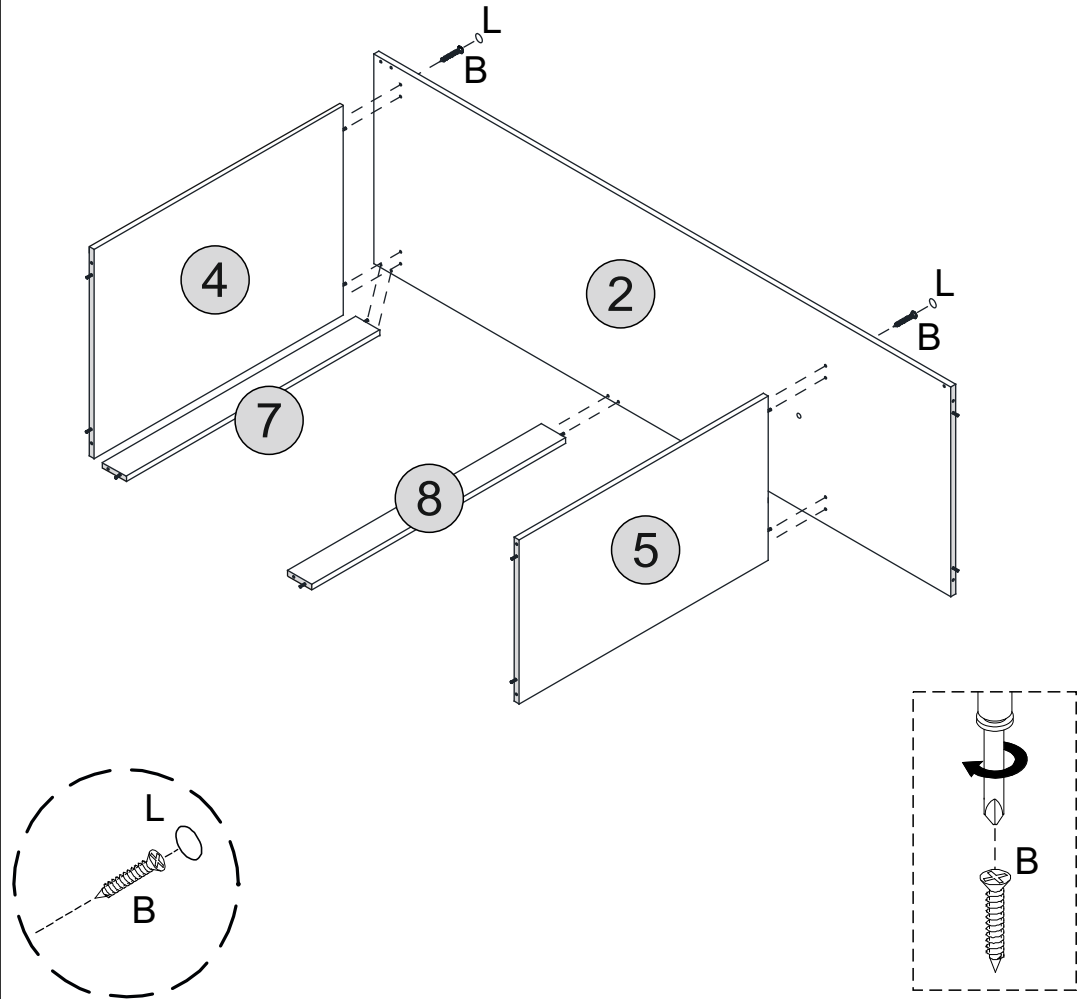
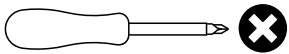



STEP 4

PARTS REQUIRED

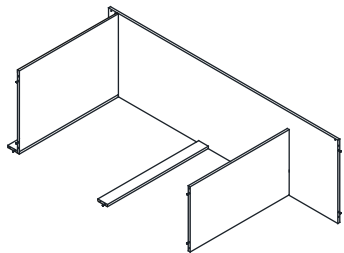
- 1 - RIGHT SIDE PANEL x1
- 6 - LOWER FRONT CROSSBAR x1
- 9 - TOP FRONT CROSSBAR x1



HARDWARE REQUIRED

- B  08
- L  08

TOOLS REQUIRED

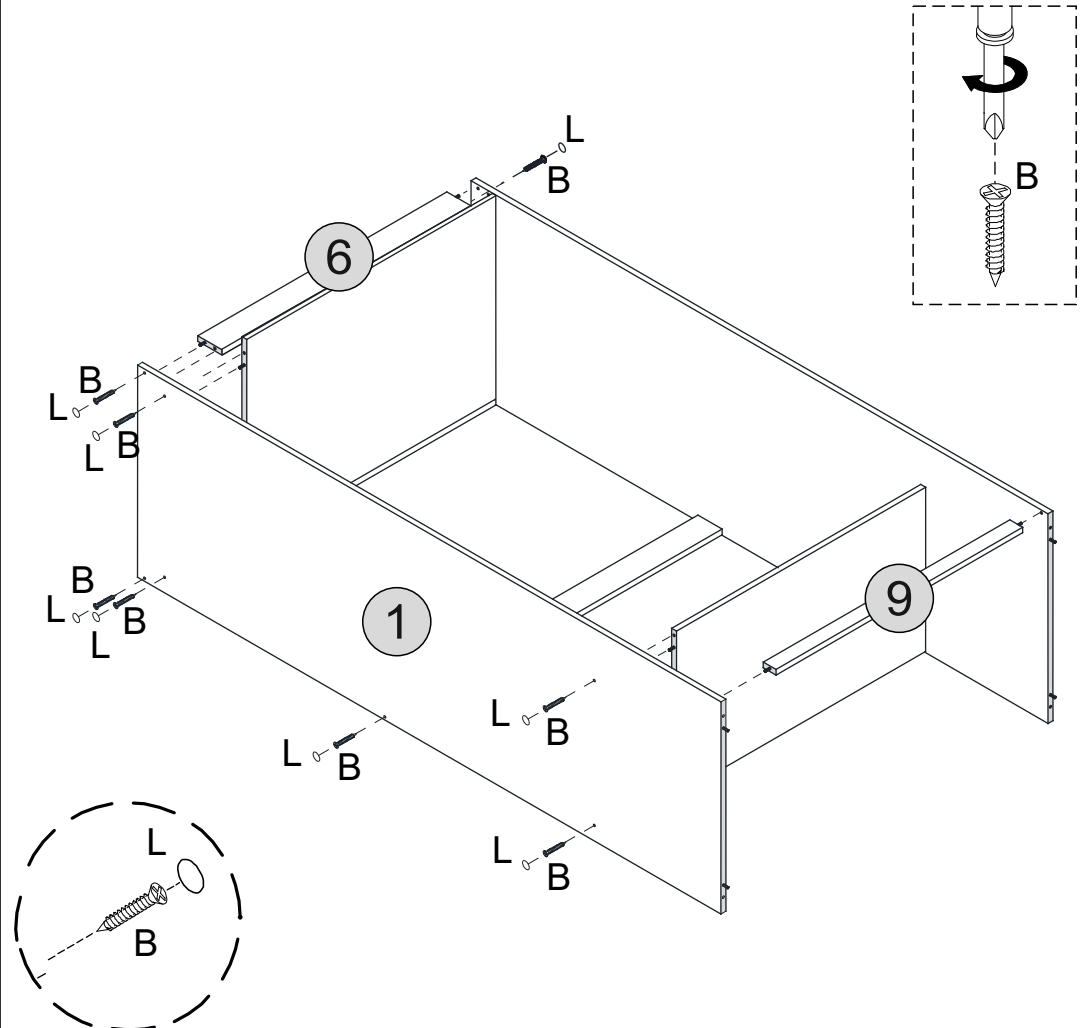
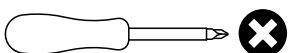

STEP 5

PARTS REQUIRED

3 - TOP PANEL x1

HARDWARE REQUIRED

C  02

I  01

TOOLS REQUIRED

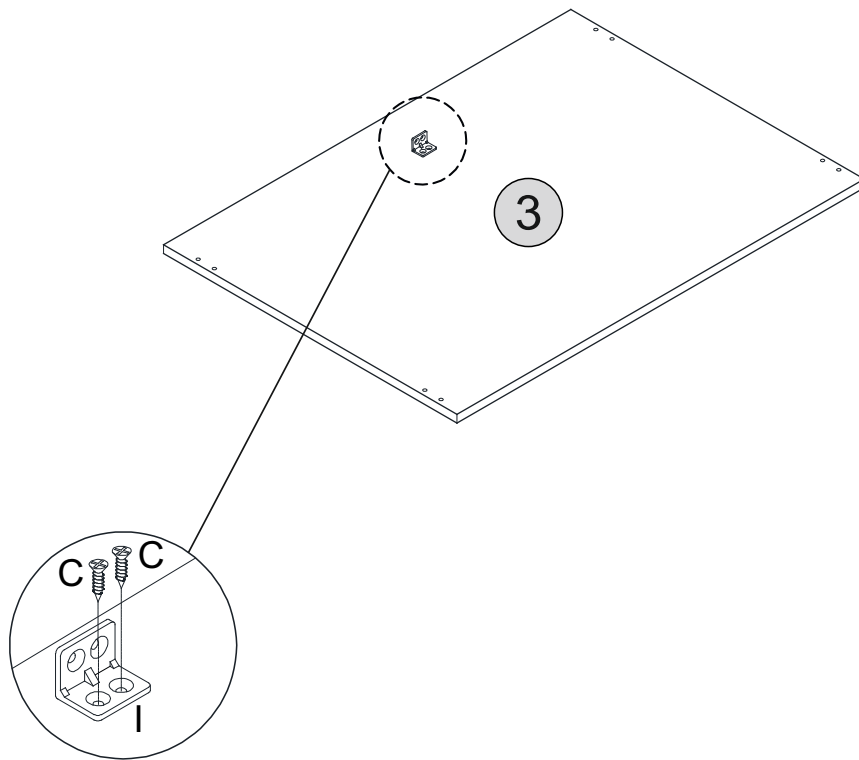
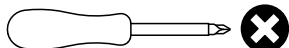

STEP 6

PARTS REQUIRED

3 - TOP PANEL x1

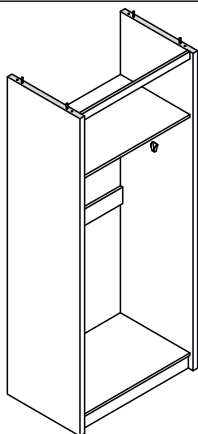

HARDWARE REQUIRED

B  04

C  06

I  01

TOOLS REQUIRED

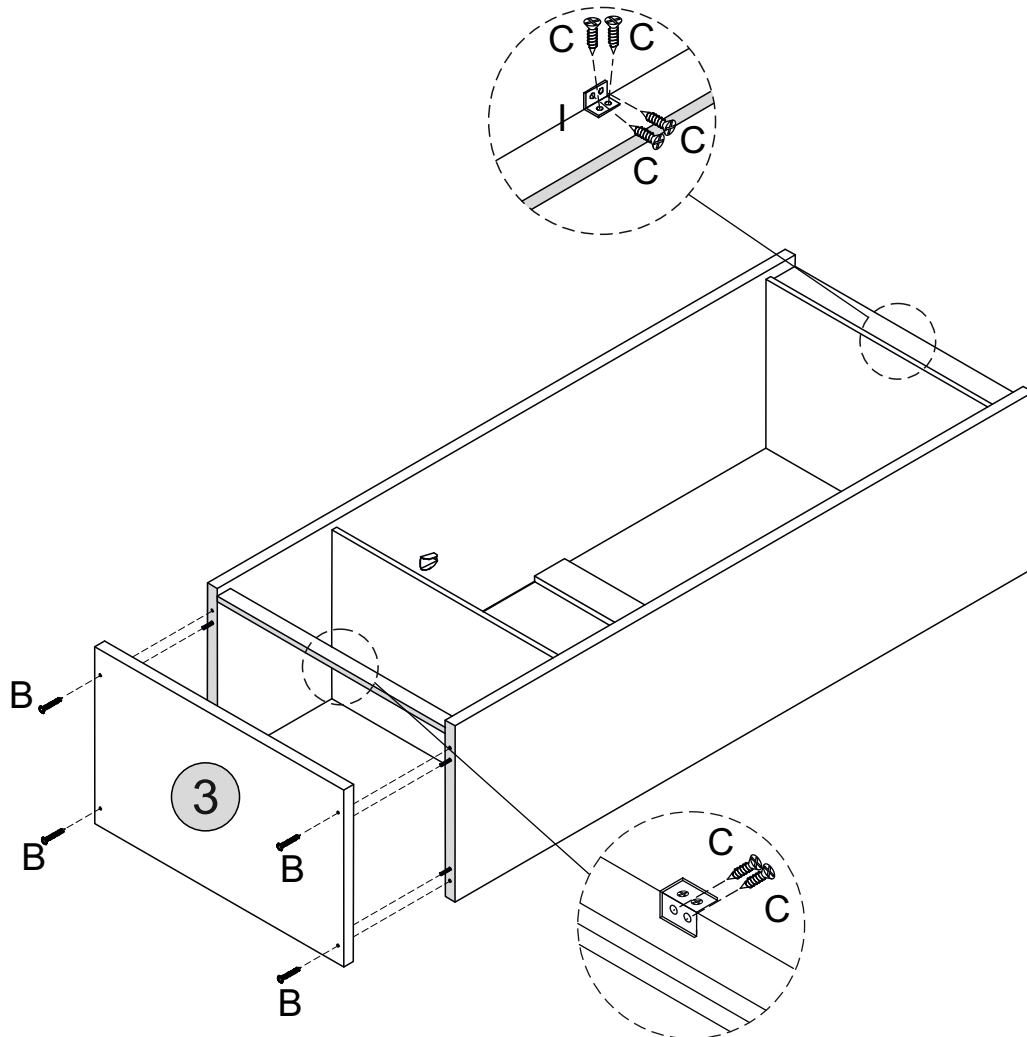
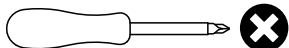

STEP 7

PARTS REQUIRED

12 - BACK PANEL x2

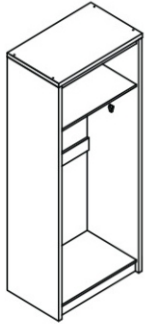

HARDWARE REQUIRED

C  4

K  46

TOOLS REQUIRED

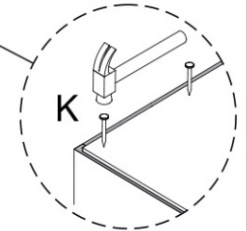
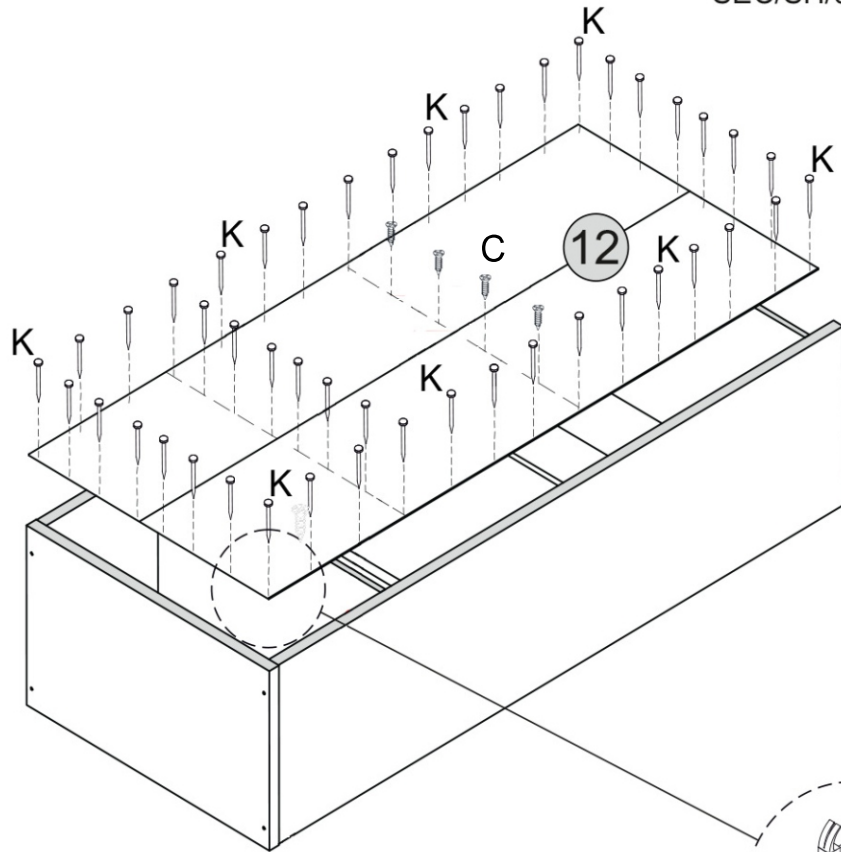

STEP 8

PARTS REQUIRED

10 - RIGHT DOOR x1

11 - LEFT DOOR x1

HARDWARE REQUIRED

C  12

E  06

TOOLS REQUIRED

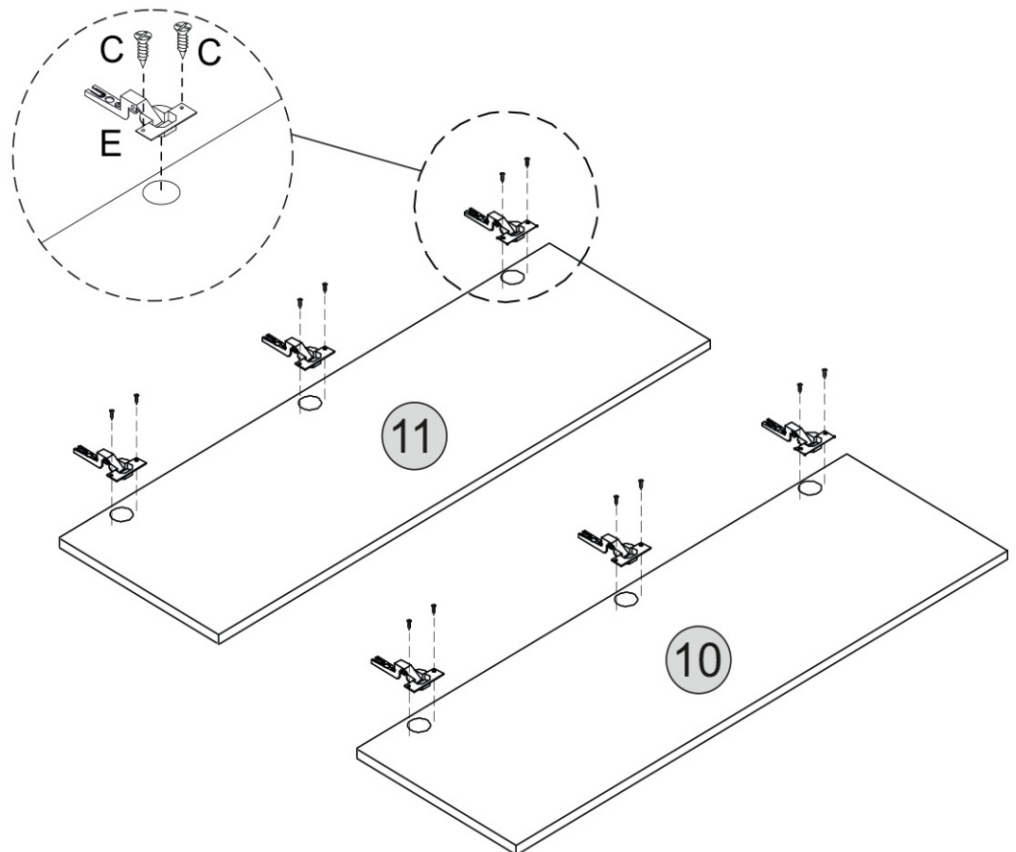

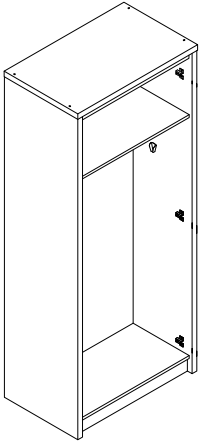

STEP 9

PARTS REQUIRED



HARDWARE REQUIRED

C		12
---	---	----

E		06
---	---	----

TOOLS REQUIRED

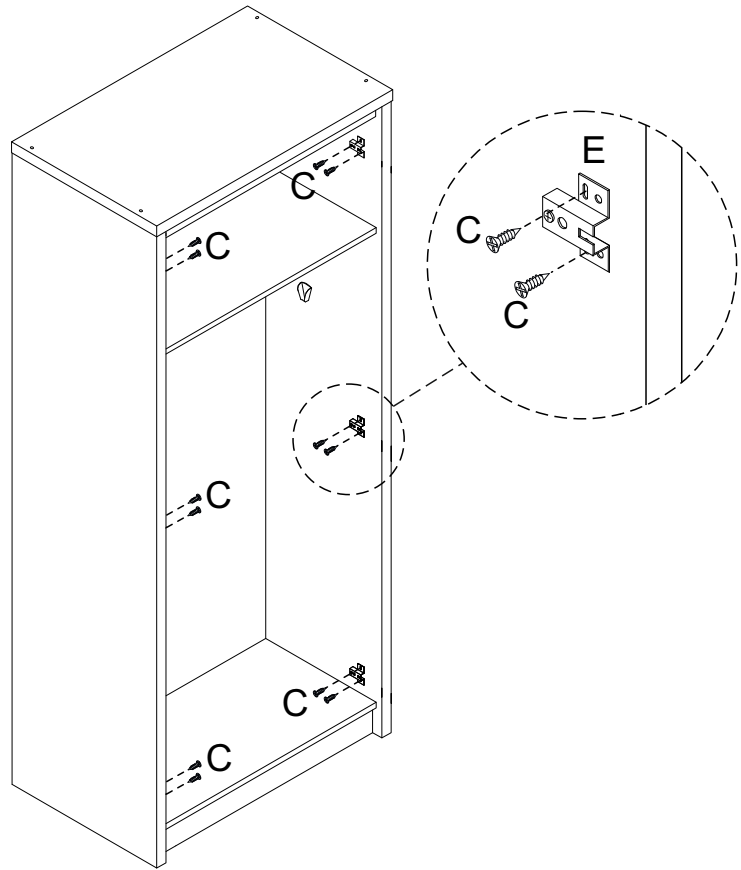
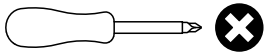

STEP 10

PARTS REQUIRED

10 - RIGHT DOOR	x1
-----------------	----

11 - LEFT DOOR	x1
----------------	----

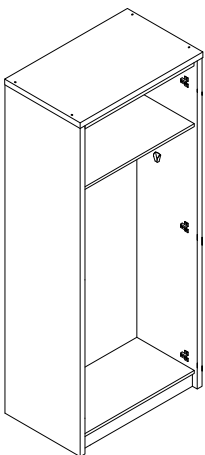

HARDWARE REQUIRED

TOOLS REQUIRED

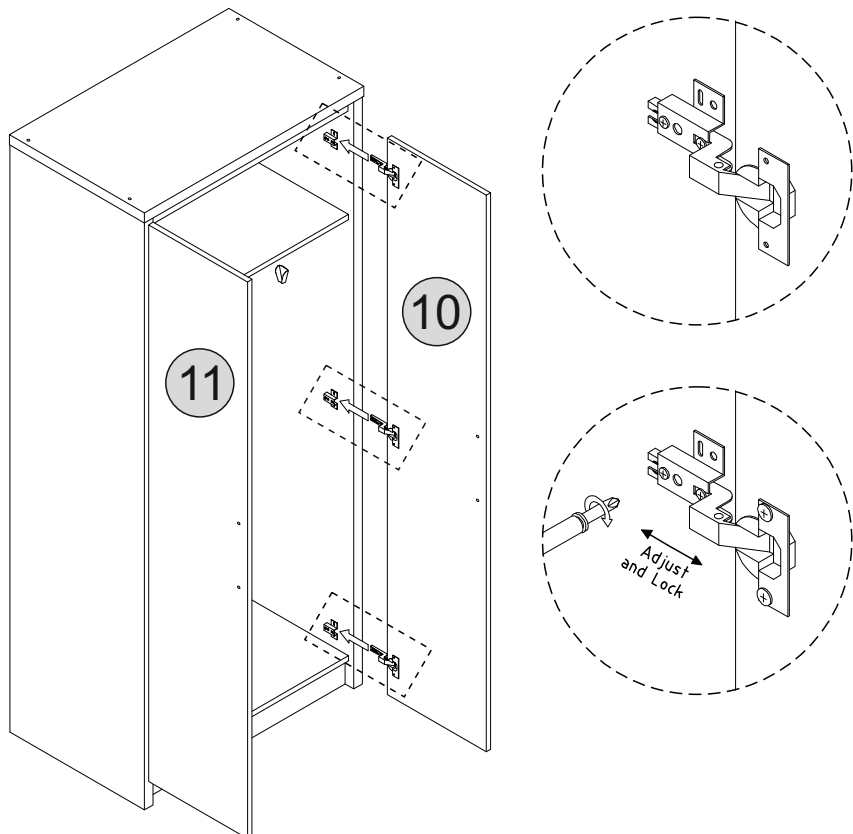
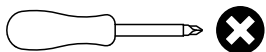

STEP 11

PARTS REQUIRED

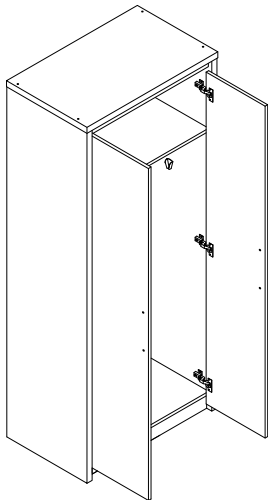

HARDWARE REQUIRED

D		01
G		02
H		04

TOOLS REQUIRED

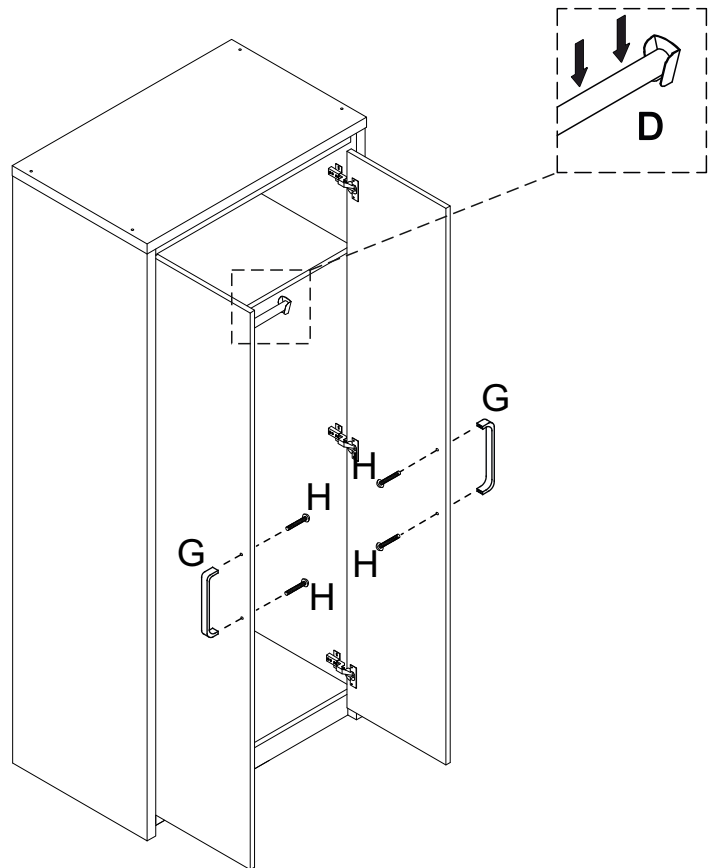
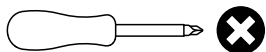

STEP 12

PARTS REQUIRED

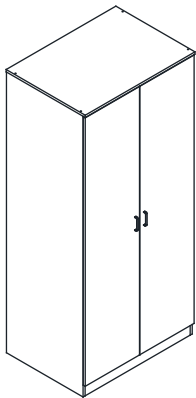

HARDWARE REQUIRED

M		01
---	--	----

TOOLS REQUIRED

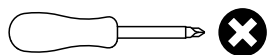

WARNING

Serious or fatal injuries can occur from furniture tipping over. To prevent the furniture from tipping over we recommend that it is permanently fixed to the wall.

Wall fixings are not supplied with this product as different wall materials require different types of fixing devices. Please make sure you use fixings suitable for the walls in your home.

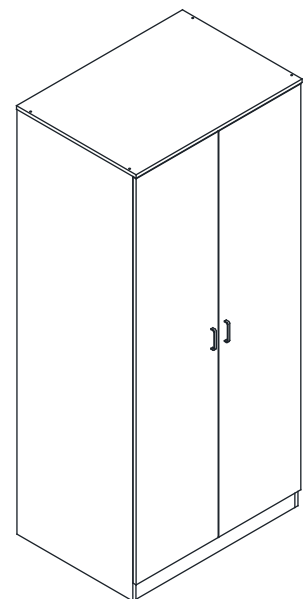
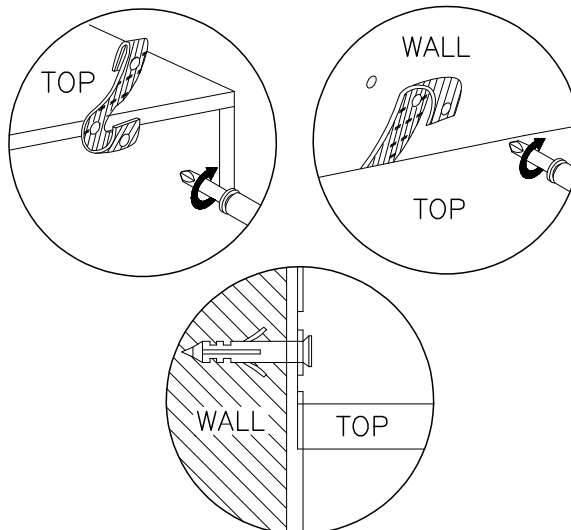

FELIX 3 DRAWER CHEST ASSEMBLY INSTRUCTIONS

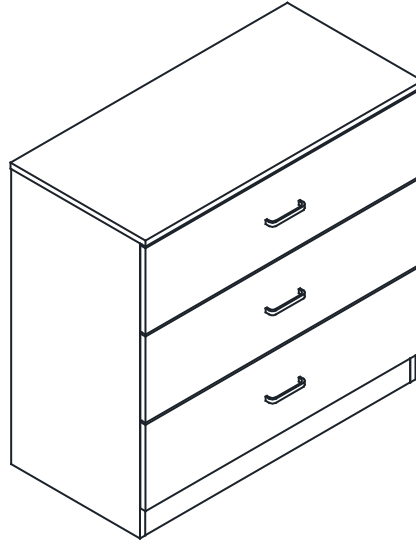

**FOR DOMESTIC USE ONLY
IMPORTANT**

PLEASE READ BEFORE YOU CONTINUE FURTHER

THE PRODUCT YOU HAVE PURCHASED WILL GIVE YOU MANY YEARS OF SERVICE IF YOU FOLLOW THE GUIDELINES FOR ITS SAFE ASSEMBLY AND PERIODIC MAINTENANCE AND CLEANING

ASSEMBLE ON A SOFT CLEAN SURFACE

DO NOT USE ANY TOOLS OTHER THAN THOSE SHOWN

ANY SPANNERS OR ALLEN KEYS REQUIRED ARE INCLUDED WITH THE FITTING KIT.

DO NOT FOR ANY REASON USE A POWER TOOL TO ASSEMBLE THIS PRODUCT. ITS USE WILL INVALIDATE ANY CLAIM YOU MAY HAVE AND COULD MAKE THIS PRODUCT UNSAFE.

DEPENDING ON THE AMOUNT OF USE THIS PRODUCT RECEIVES, IT MAY BE NECESSARY TO TIGHTEN UP THE FIXINGS FROM TIME TO TIME. THIS IS COMPLETELY NORMAL FOR ANY FLAT PACK FURNITURE. DO NOT OVERTIGHTEN FIXINGS.



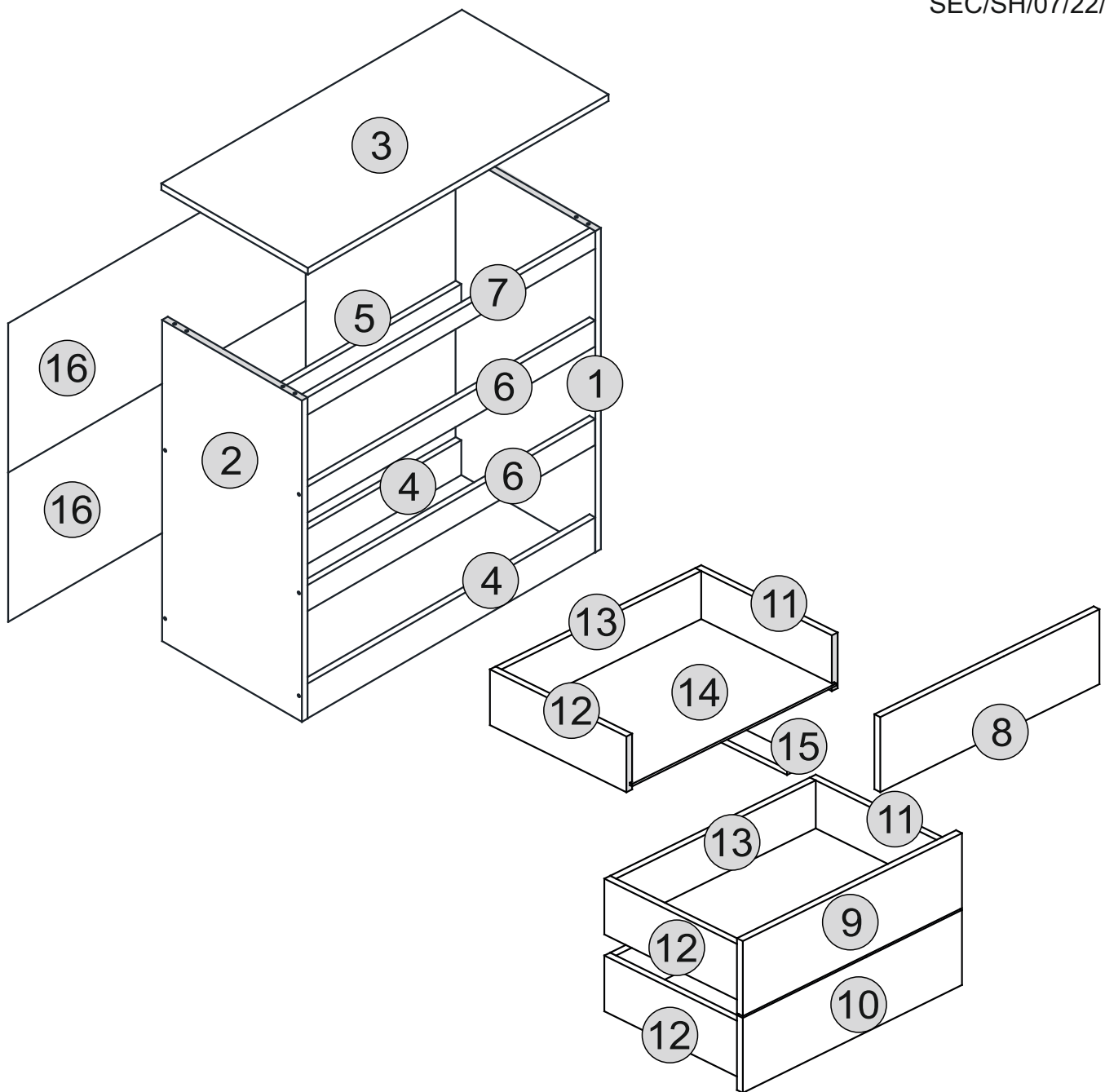

FOR CLEANING, YOU MAY USE A DAMP CLOTH (NOT WET). DO NOT USE POLISH, DETERGENT OR CHEMICAL CLEANERS.

THE SURFACE OF THIS ITEM IS NOT HEAT RESISTANT. ALWAYS USE A PLACE MAT UNDER HOT OR COLD ITEMS TO PREVENT MARKING.



Part Number	Part Code	Part Description	Quantity	Carton
1	S100-102-112-TA1-01	Right Side Panel	1	1/1
2	S100-102-112-TA1-02	Left Side Panel	1	1/1
3	S100-102-112-TA1-03	Top Panel	1	1/1
4	S100-102-112-TA1-04	Bottom Support Panel	2	1/1
5	S100-102-112-TA1-05	Back Support Panel	1	1/1
6	S100-102-112-TA1-06	Front Support Panel	2	1/1
7	S100-102-112-TA1-07	Top Support Panel	1	1/1
8	S100-102-112-TA1-08	Top Drawer Front	1	1/1
9	S100-102-112-TA1-09	Centre Drawer Front	1	1/1
10	S100-102-112-TA1-10	Bottom Drawer Front	1	1/1
11	S100-102-112-TA1-11	Right Drawer Side	3	1/1
12	S100-102-112-TA1-12	Left Drawer Side	3	1/1
13	S100-102-112-TA1-13	Drawer Back	3	1/1
14	S100-102-112-TA1-14	Drawer Base	3	1/1
15	S100-102-112-TA1-15	Drawer Support	3	1/1
16	S100-102-112-TA1-16	Back Panel	2	1/1

HARDWARE LIST

No.	Part Name		Qty
A	Wooden Dowel (6x25mm)		28
B	45mm Screw (4x45mm)		10
C	16mm Screw (3.5x14mm)		34
D	38mm Screw (4x38mm)		15
E	Cam Bolt (8032T)		13
F	Cam Nut (1510)		13
G	Handle (AL96mm)		3
H	Handle Screw		6
I	PVC L-Bracket		1
J	Plastic Foot		4
K	Nail		20
L	Screw Cover (Sticker 12mm)		10
M	Wall Fixings (4x20mm=1pc)		1
N	14" Drawer Slide (0.9mm)		3

TIPS FOR FITTING CAM-LOCKS

WHEN FITTING THE CAM-LOCK
ENSURE STARTING POSITION IS CORRECT
BEFORE YOU INSERT CONNECTING CAM BOLT
TURN CLOCKWISE UNTIL SECURE

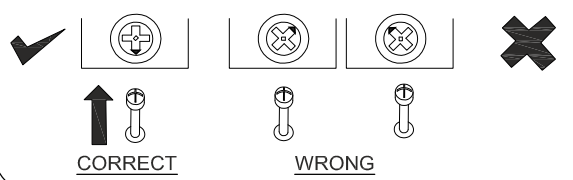

CORRECT **WRONG**

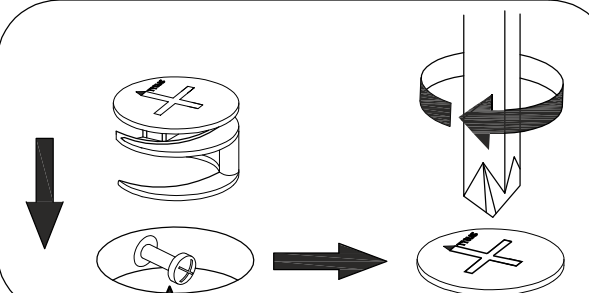

CAMBOLT

Tighten until shoulder is flush with panel. Do not overtighten or undertighten (see example below)

Cam bolt head needs to be in centre

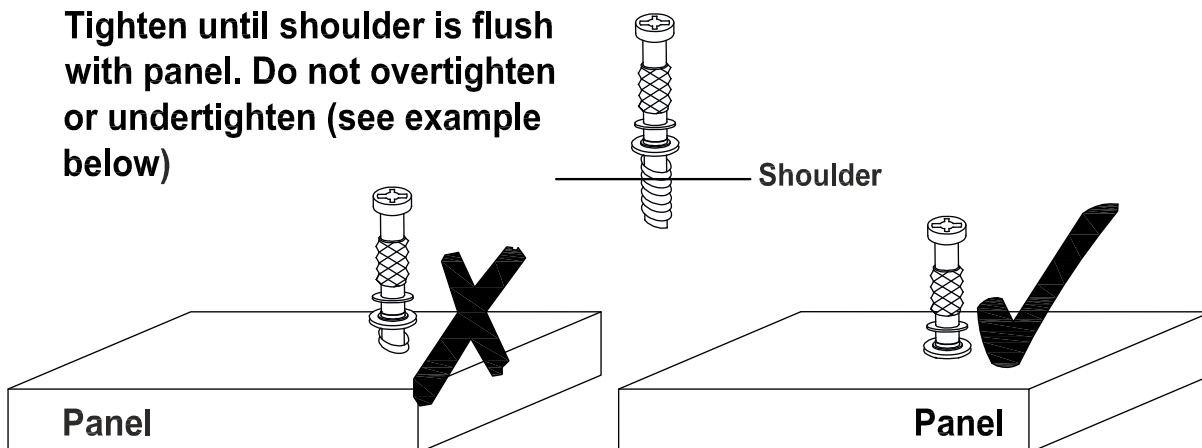

Panel Panel

Shoulder

STEP 1

PARTS REQUIRED

4 - BOTTOM SUPPORT PANEL x1

5 - BACK SUPPORT PANEL x1

6 - FRONT SUPPORT PANEL x1

7 - TOP SUPPORT PANEL x1

HARDWARE REQUIRED

A  12

TOOLS REQUIRED

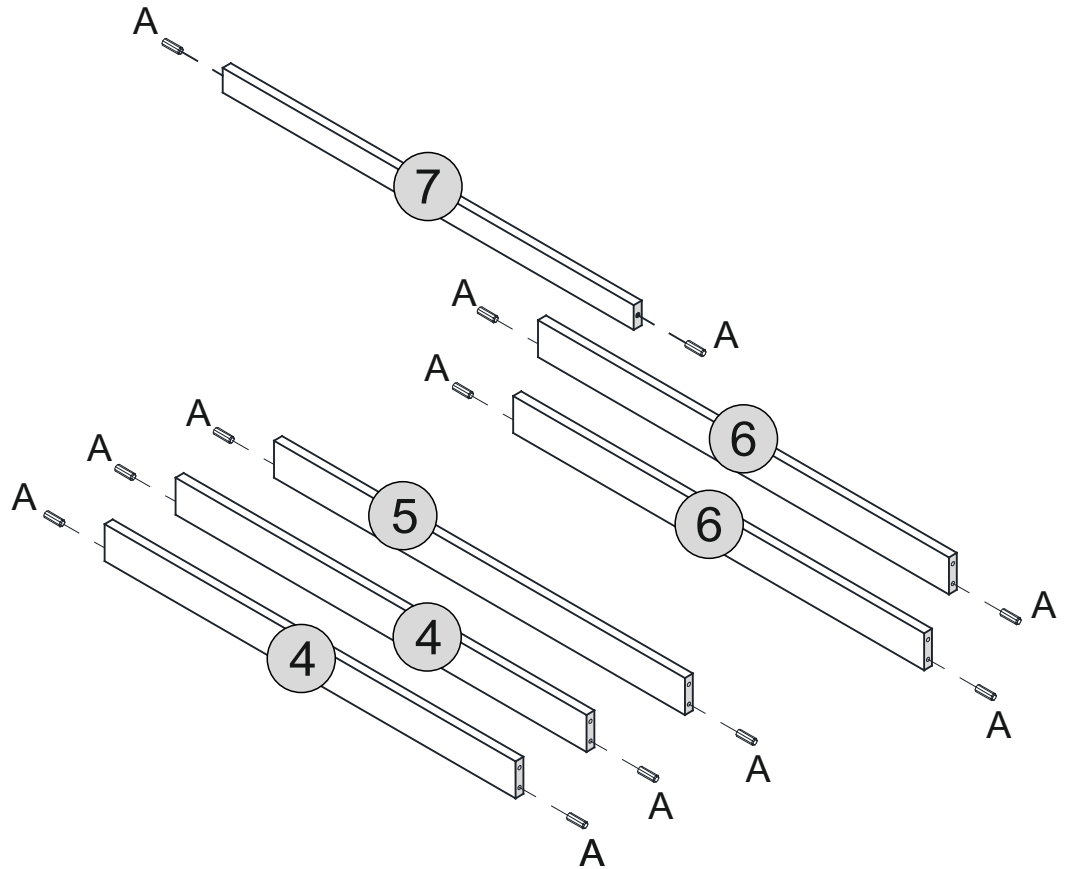

STEP 2

PARTS REQUIRED

1 - RIGHT SIDE PANEL x1

2 - LEFT SIDE PANEL x1

HARDWARE REQUIRED

A  04

C  12

F  04

J  04

N  06

TOOLS REQUIRED

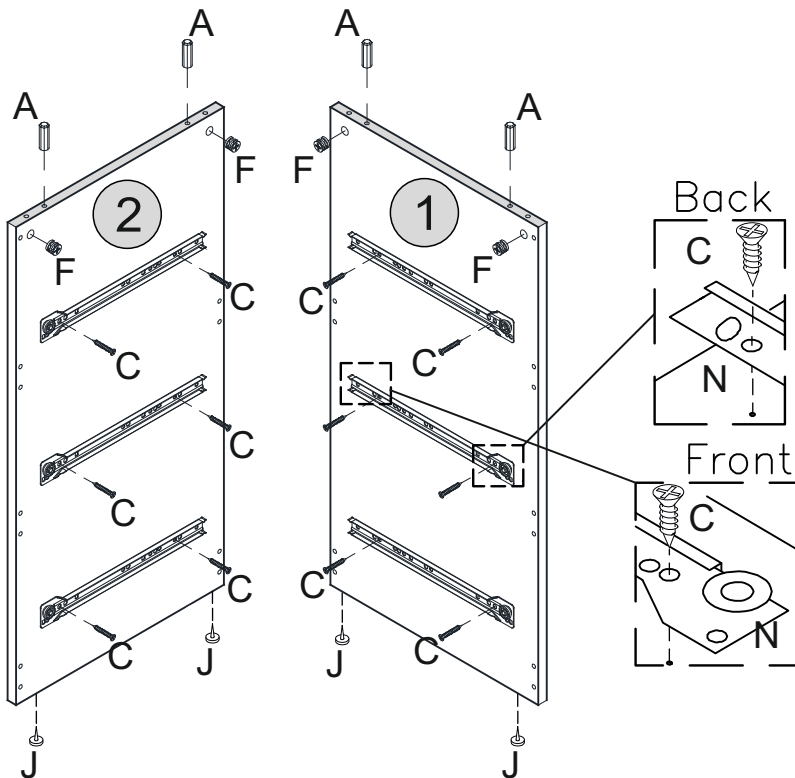
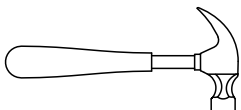
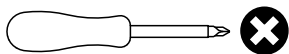

To Assemble the Drawer Slide, Please Follow Step as Below

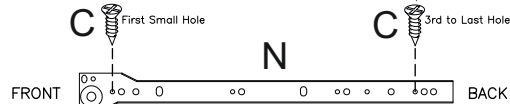

STEP 3

PARTS REQUIRED

3 - TOP PANEL x1

HARDWARE REQUIRED

C  02

E  04

I  01

TOOLS REQUIRED

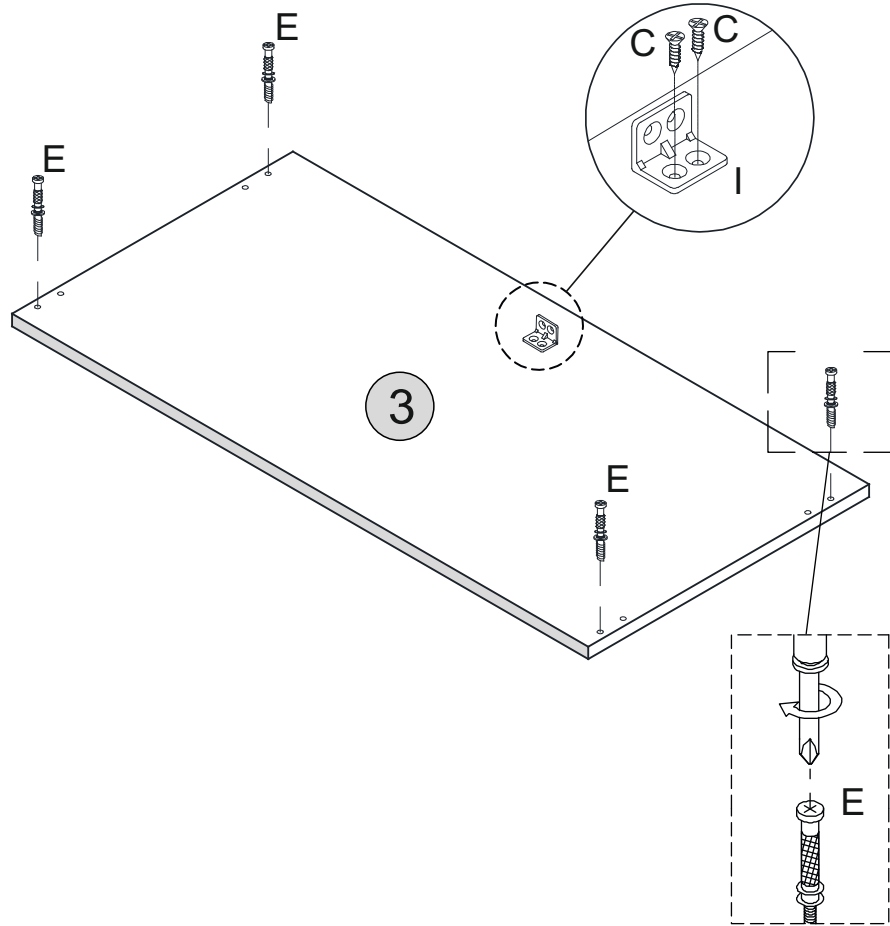
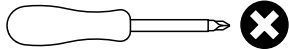

STEP 4

PARTS REQUIRED

2 - LEFT SIDE PANEL x1

4 - BOTTOM SUPPORT PANEL x2

5 - BACK SUPPORT PANEL x1

6 - FRONT SUPPORT PANEL x2

7 - TOP SUPPORT PANEL x1

HARDWARE REQUIRED

B  05

L  05

TOOLS REQUIRED

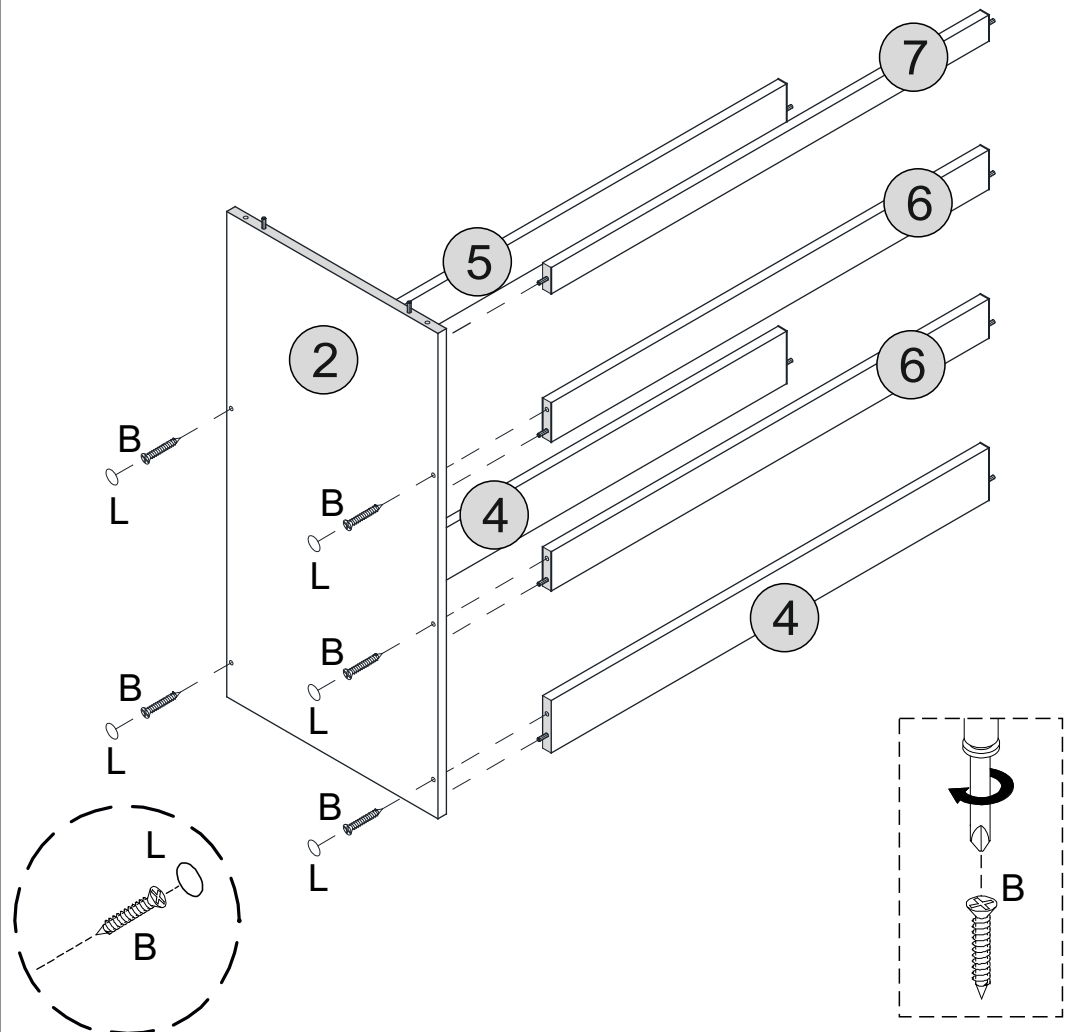
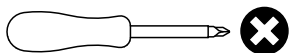

STEP 5

PARTS REQUIRED

1 - RIGHT SIDE PANEL x1

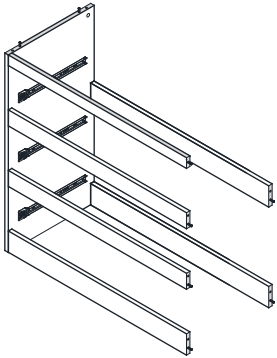

HARDWARE REQUIRED

B  05

L  05

TOOLS REQUIRED

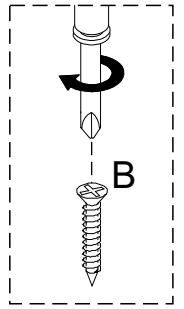
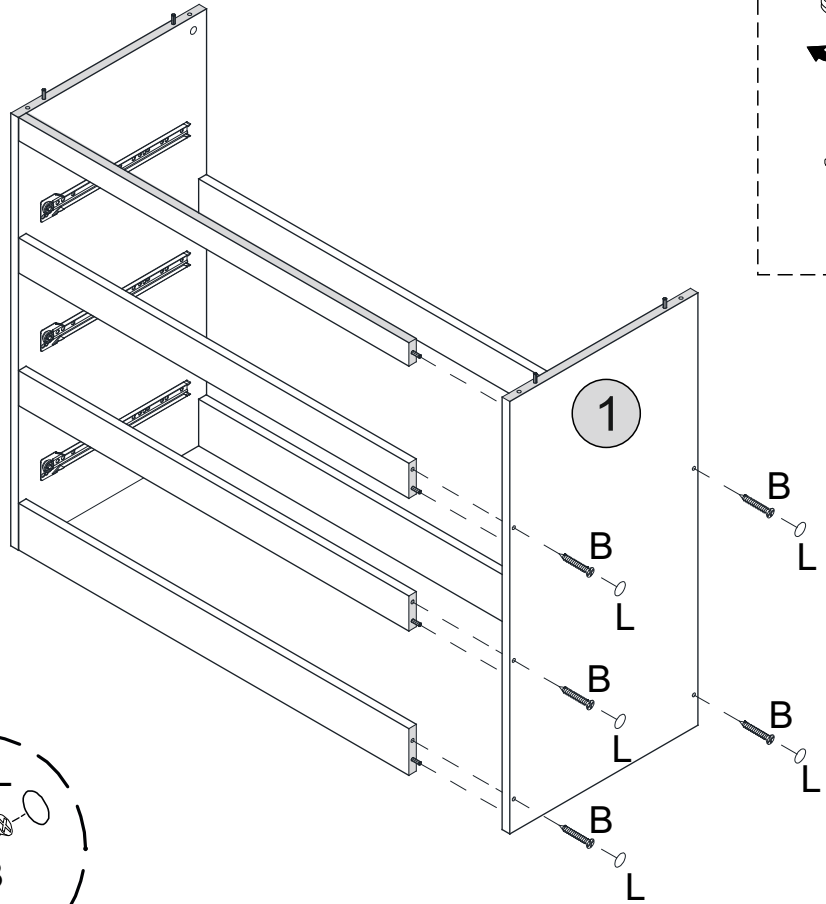
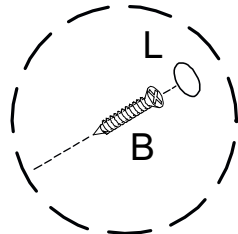
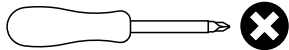

STEP 6

PARTS REQUIRED

3 - TOP PANEL x1

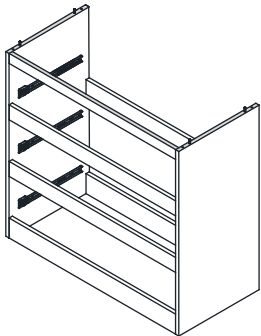

HARDWARE REQUIRED

C  02

TOOLS REQUIRED

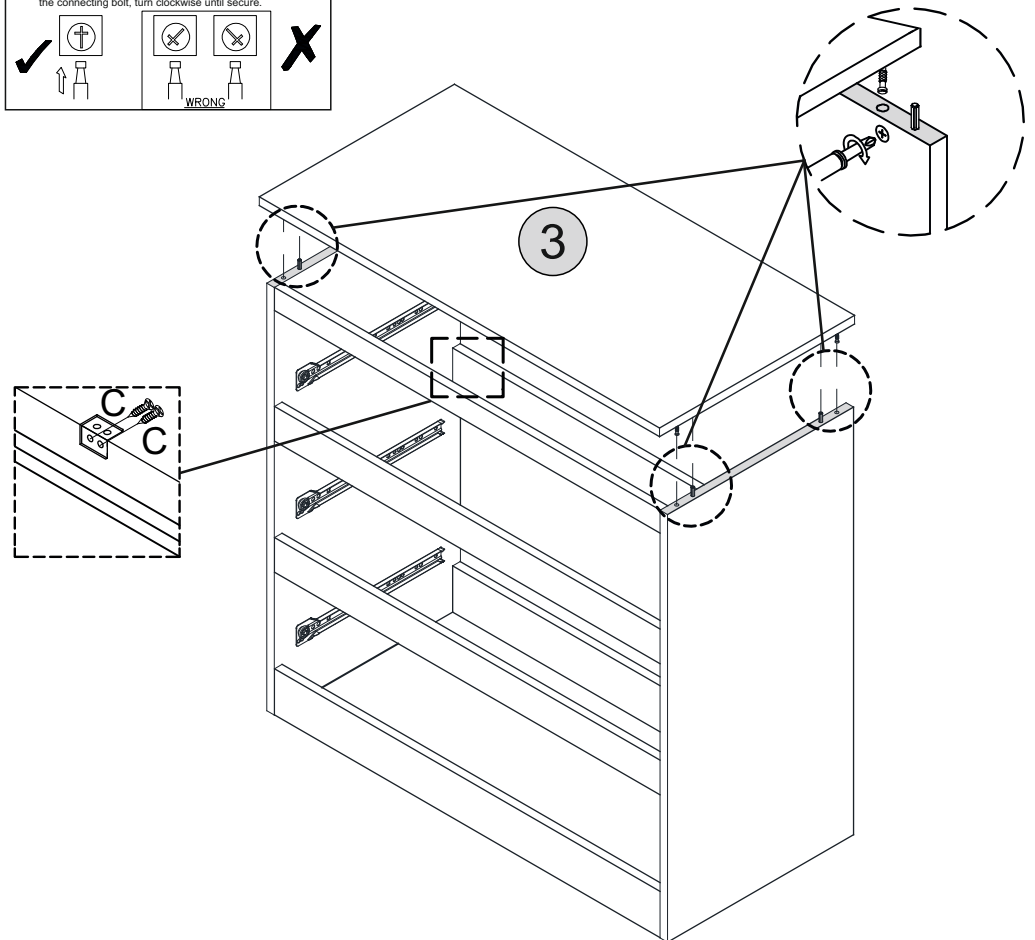
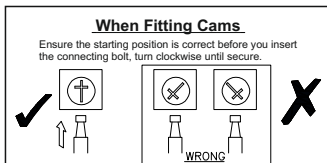
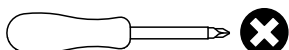

STEP 7

PARTS REQUIRED

16 - BACK PANEL x2

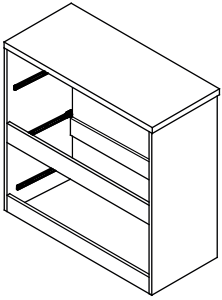

HARDWARE REQUIRED

C  06

K  22

TOOLS REQUIRED

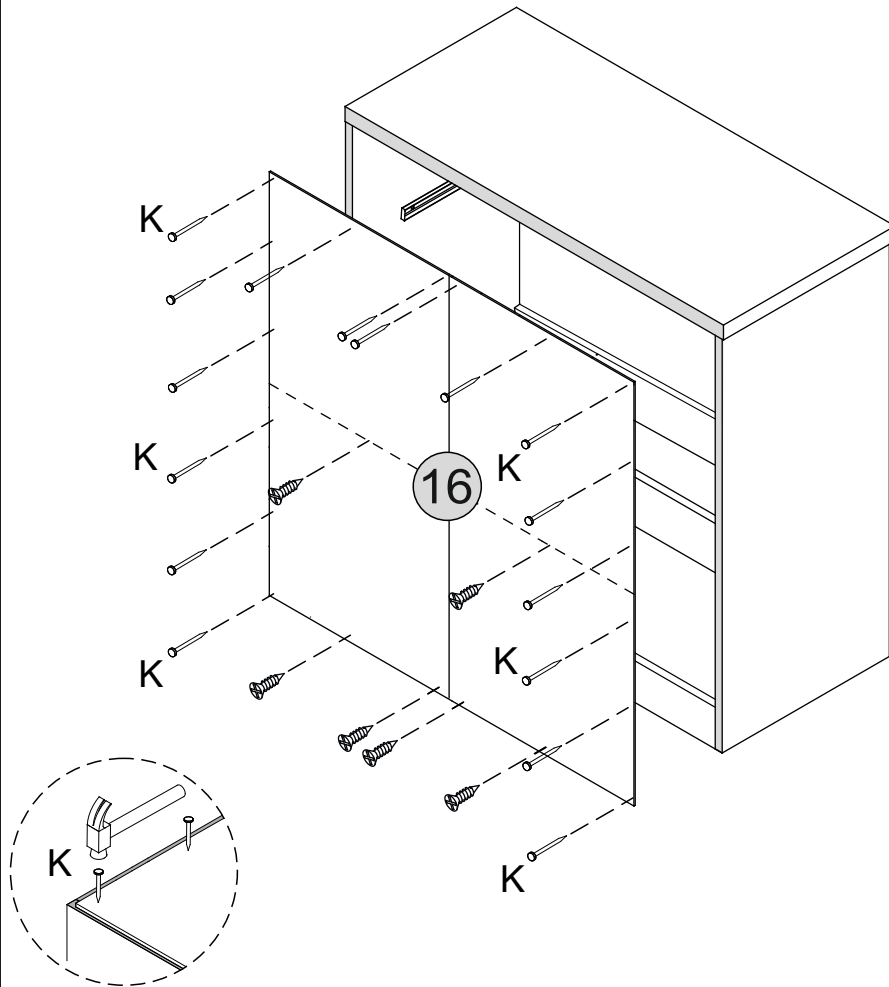
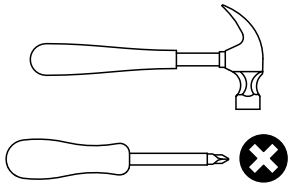

STEP 8

PARTS REQUIRED

8 - TOP DRAWER FRONT x1

9 - CENTRE DRAWER FRONT x1

10 - BOTTOM DRAWER FRONT x1

11 - RIGHT DRAWER SIDE x3

12 - LEFT DRAWER SIDE x3

15 - DRAWER SUPPORT x3

HARDWARE REQUIRED

A  12





E  09

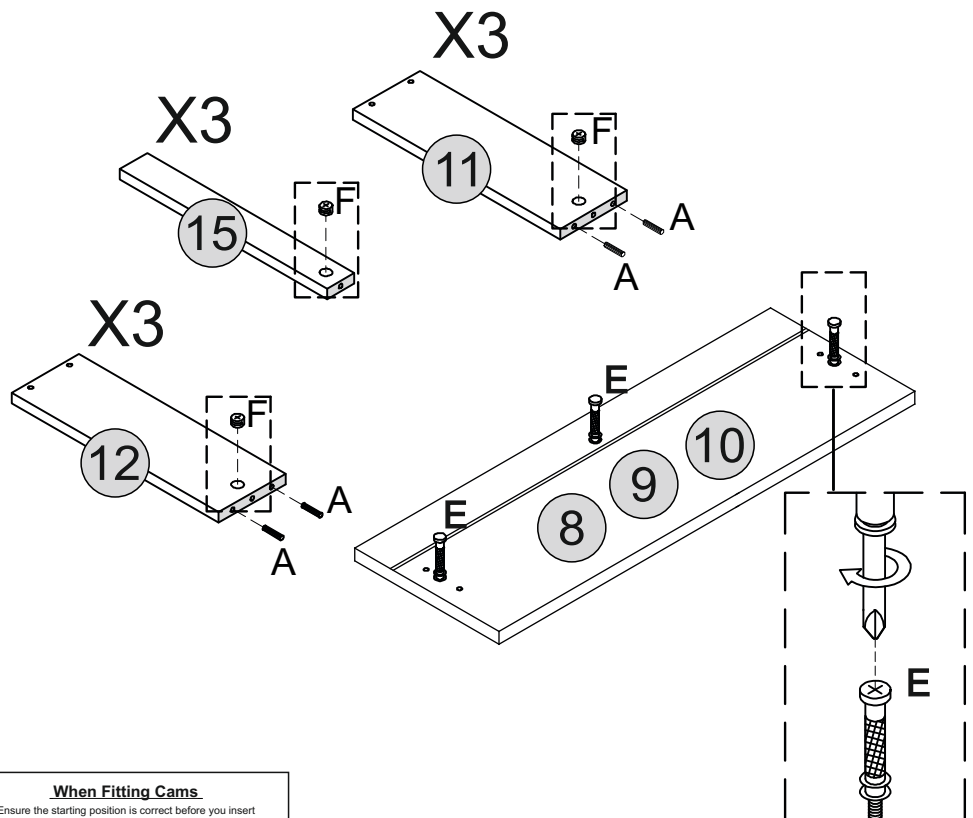
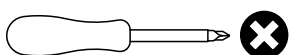



F  09





TOOLS REQUIRED







When Fitting Cams
 Ensure the starting position is correct before you insert the connecting bolt, turn clockwise until secure.

↑    

↑    

↑    

↑    

STEP 9

PARTS REQUIRED

- 11 - RIGHT DRAWER SIDE x3
- 12 - LEFT DRAWER SIDE x3
- 13 - DRAWER BACK x3
- 14 - DRAWER BASE x3
- 15 - DRAWER SUPPORT x3

HARDWARE REQUIRED



TOOLS REQUIRED

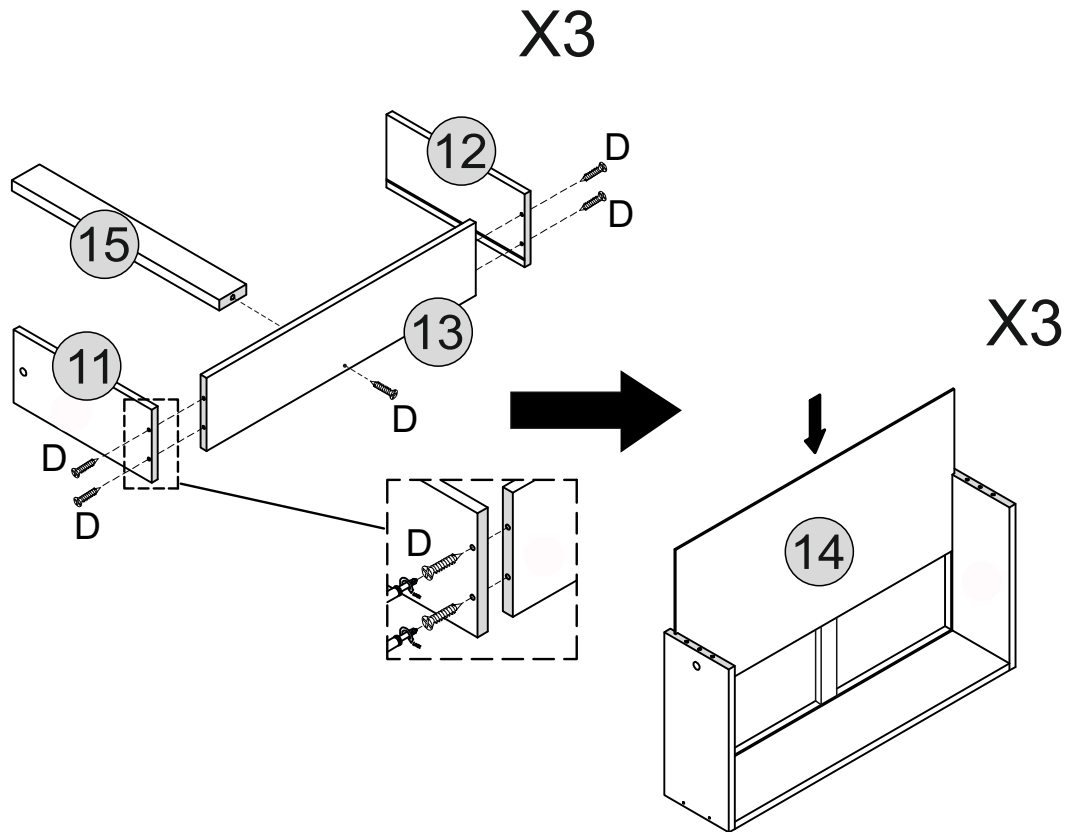
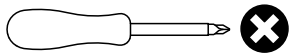

STEP 10

PARTS REQUIRED

- 8 - TOP DRAWER FRONT x1
- 9 - CENTRE DRAWER FRONT x1
- 10 - BOTTOM DRAWER FRONT x1

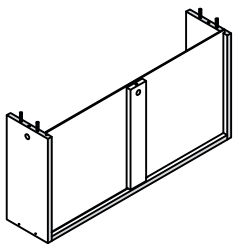

HARDWARE REQUIRED

TOOLS REQUIRED

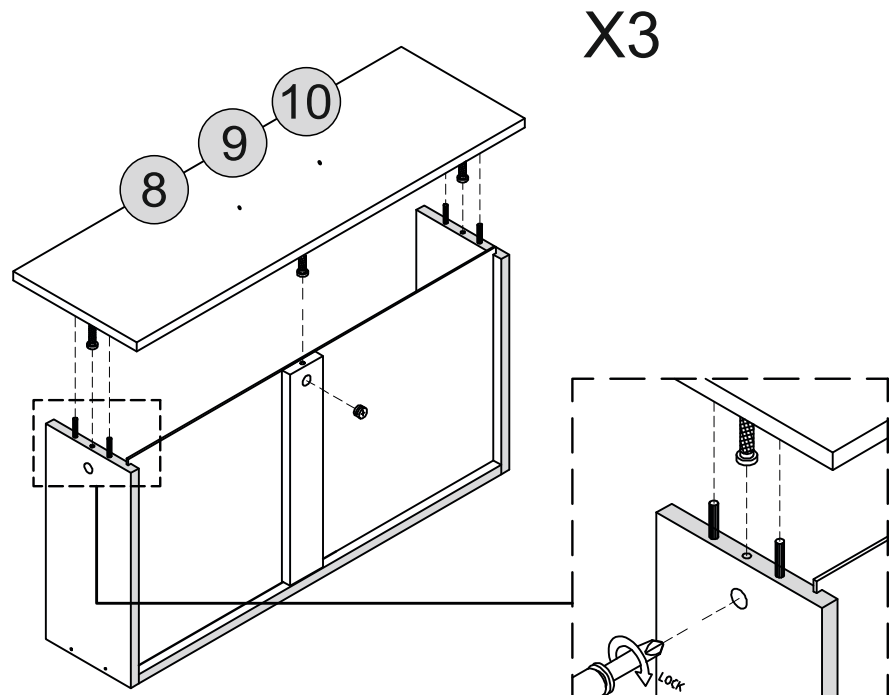
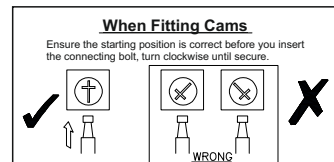
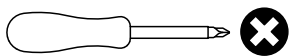

STEP 11

PARTS REQUIRED

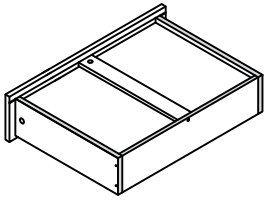

HARDWARE REQUIRED

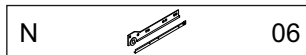
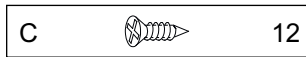

TOOLS REQUIRED

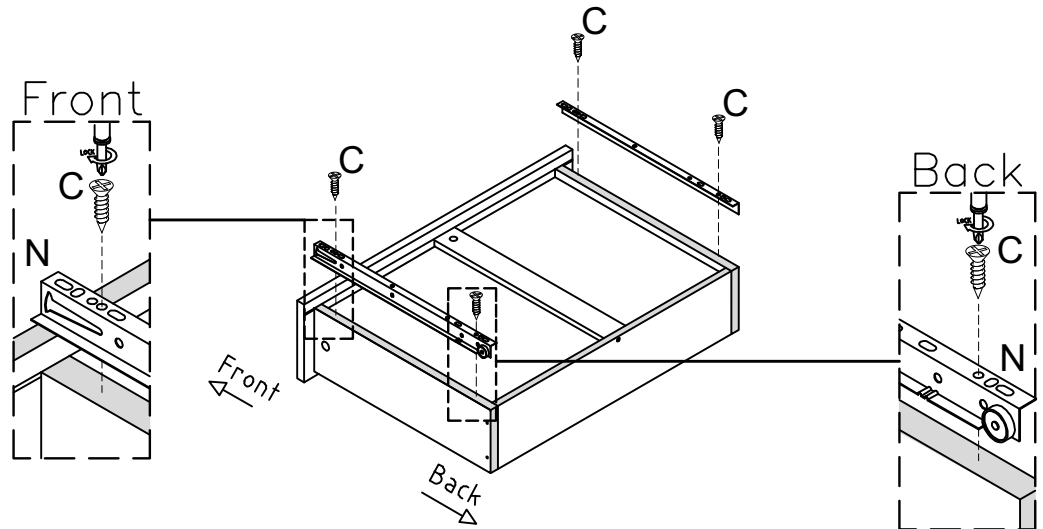
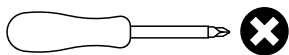

STEP 12

PARTS REQUIRED

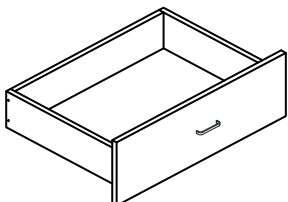

HARDWARE REQUIRED

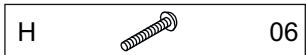
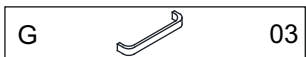

TOOLS REQUIRED

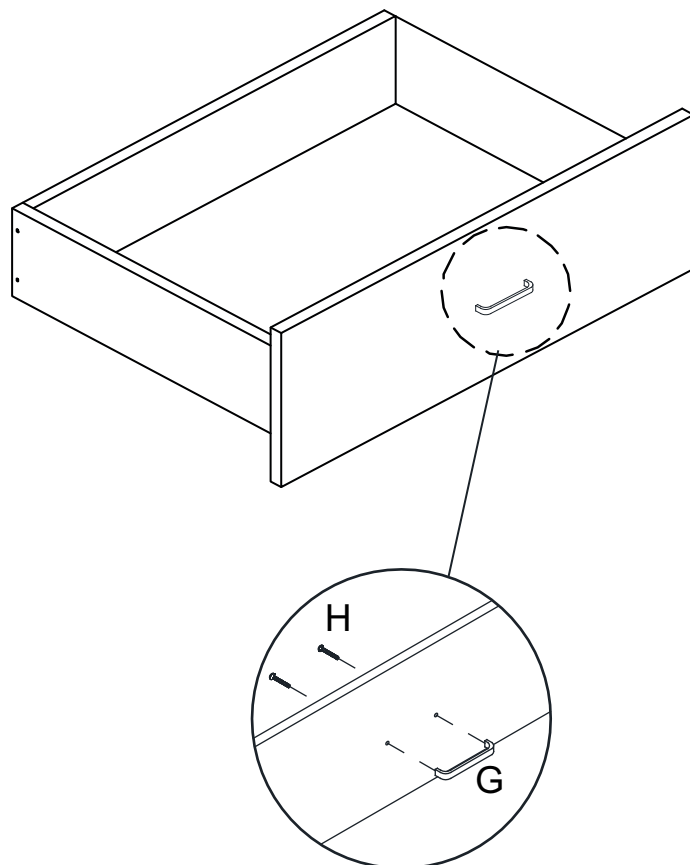
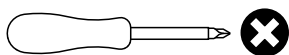

STEP 13

PARTS REQUIRED

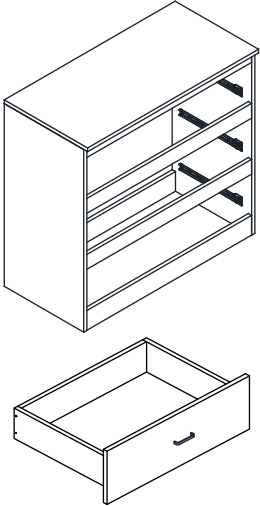

HARDWARE REQUIRED

TOOLS REQUIRED

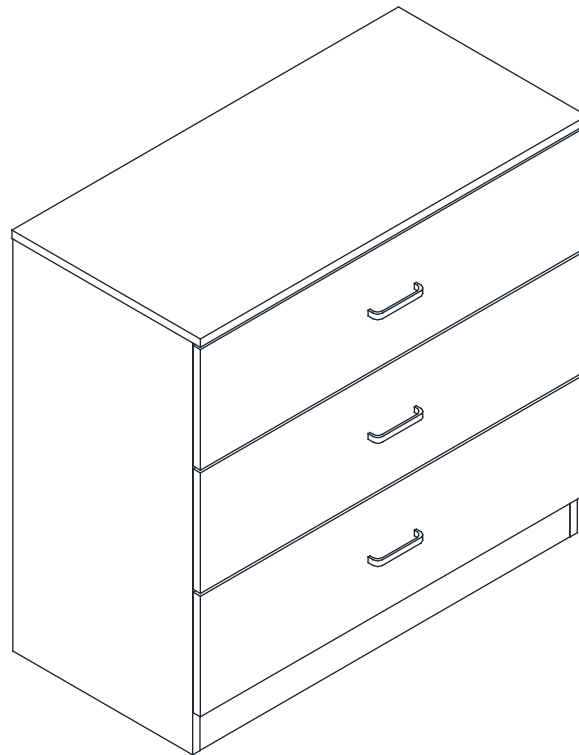

FINISH

STEP 14

PARTS REQUIRED

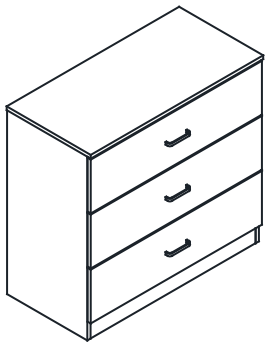

HARDWARE REQUIRED



TOOLS REQUIRED

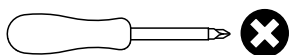

WARNING

Serious or fatal injuries can occur from furniture tipping over. To prevent the furniture from tipping over we recommend that it is permanently fixed to the wall.

Wall fixings are not supplied with this product as different wall materials require different types of fixing devices. Please make sure you use fixings suitable for the walls in your home.

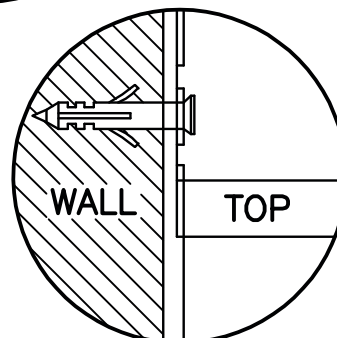
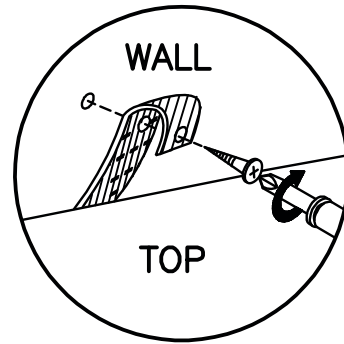
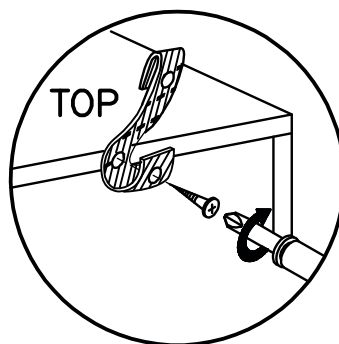

FELIX 2 DRAWER BEDSIDE ASSEMBLY INSTRUCTIONS

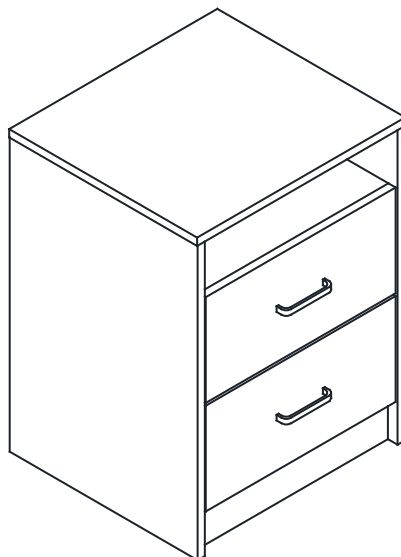

FOR DOMESTIC USE ONLY IMPORTANT

PLEASE READ BEFORE YOU CONTINUE FURTHER

THE PRODUCT YOU HAVE PURCHASED WILL GIVE YOU MANY YEARS OF SERVICE IF YOU FOLLOW THE GUIDELINES FOR ITS SAFE ASSEMBLY AND PERIODIC MAINTENANCE AND CLEANING

ASSEMBLE ON A SOFT CLEAN SURFACE

DO NOT USE ANY TOOLS OTHER THAN THOSE SHOWN

ANY SPANNERS OR ALLEN KEYS REQUIRED ARE INCLUDED WITH THE FITTING KIT.

DO NOT FOR ANY REASON USE A POWER TOOL TO ASSEMBLE THIS PRODUCT. ITS USE WILL INVALIDATE ANY CLAIM YOU MAY HAVE AND COULD MAKE THIS PRODUCT UNSAFE.

DEPENDING ON THE AMOUNT OF USE THIS PRODUCT RECEIVES, IT MAY BE NECESSARY TO TIGHTEN UP THE FIXINGS FROM TIME TO TIME. THIS IS COMPLETELY NORMAL FOR ANY FLAT PACK FURNITURE. DO NOT OVERTIGHTEN FIXINGS.





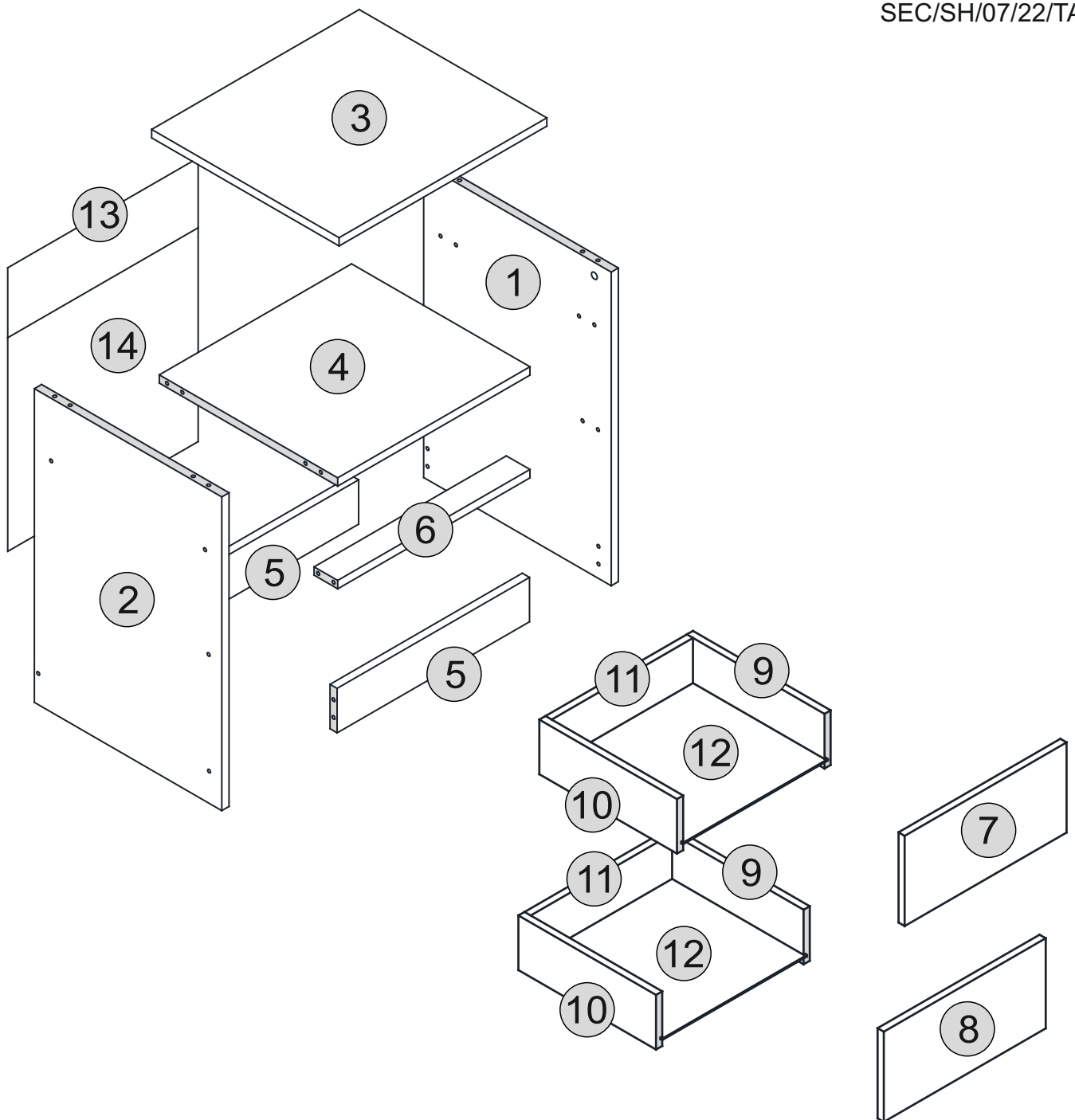



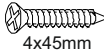

FOR CLEANING, YOU MAY USE A DAMP CLOTH (NOT WET). DO NOT USE POLISH, DETERGENT OR CHEMICAL CLEANERS.

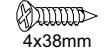
THE SURFACE OF THIS ITEM IS NOT HEAT RESISTANT. ALWAYS USE A PLACE MAT UNDER HOT OR COLD ITEMS TO PREVENT MARKING.



Part Number	Part Code	Part Description	Quantity	Carton
1	S100-103-061-TA1-01	Right Side Panel	1	1/1
2	S100-103-061-TA1-02	Left Side Panel	1	1/1
3	S100-103-061-TA1-03	Top Panel	1	1/1
4	S100-103-061-TA1-04	Shelf	1	1/1
5	S100-103-061-TA1-05	Lower Crossbar	2	1/1
6	S100-103-061-TA1-06	Middle Crossbar	1	1/1
7	S100-103-061-TA1-07	Top Drawer Front	1	1/1
8	S100-103-061-TA1-08	Bottom Drawer Front	1	1/1
9	S100-103-061-TA1-09	Right Drawer Side	2	1/1
10	S100-103-061-TA1-10	Left Drawer Side	2	1/1
11	S100-103-061-TA1-11	Drawer Back	2	1/1
12	S100-103-061-TA1-12	Drawer Base	2	1/1
13	S100-103-061-TA1-13	Back Panel (Small)	1	1/1
14	S100-103-061-TA1-14	Back Panel	1	1/1

HARDWARE LIST

No.	Part Name		Qty
A	Wooden Dowel (6x25mm)		22
B	45mm Screw (4x45mm)		10
C	16mm Screw (3.5x14mm)		16
D	38mm Screw (4x38mm)		8
E	Cam Bolt (8032T)		8
F	Cam Nut		8
G	Handle (AL96mm)		2
H	Handle Screw		4
I	14" Drawer Slide		2
J	Plastic Foot		4
K	Nail		20
L	Screw Cover		10

TIPS FOR FITTING CAM-LOCKS

WHEN FITTING THE CAM-LOCK
ENSURE STARTING POSITION IS CORRECT
BEFORE YOU INSERT CONNECTING CAM BOLT
TURN CLOCKWISE UNTIL SECURE

CORRECT **WRONG**

Cam bolt head needs to be in centre

CAMBOLT

Tighten until shoulder is flush with panel. Do not overtighten or undertighten (see example below)

Panel **Panel**



Shoulder

STEP 1

PARTS REQUIRED

3 - TOP PANEL	x1
4 - SHELF	x1
5 - LOWER CROSSBAR	x2
6 - MIDDLE CROSSBAR	x1

HARDWARE REQUIRED

A		10
E		04

TOOLS REQUIRED

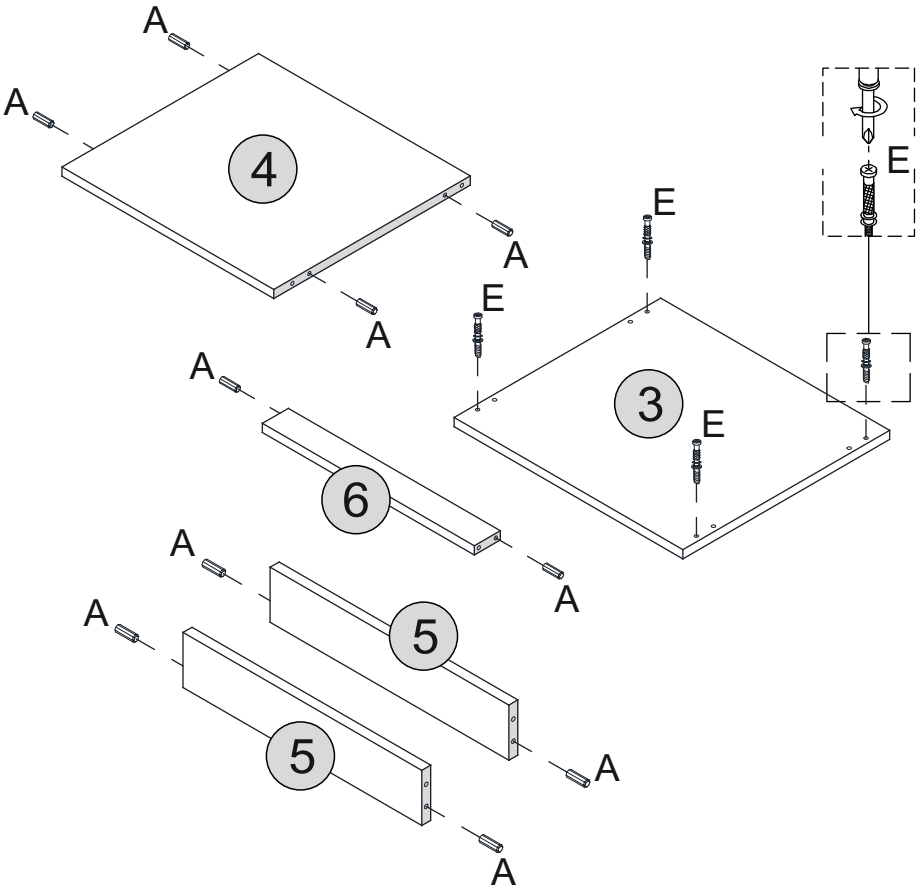
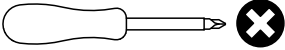





STEP 2

PARTS REQUIRED

1 - RIGHT SIDE PANEL	x1
2 - LEFT SIDE PANEL	x1

HARDWARE REQUIRED

A		04
C		08
F		04
I		04
J		04

TOOLS REQUIRED

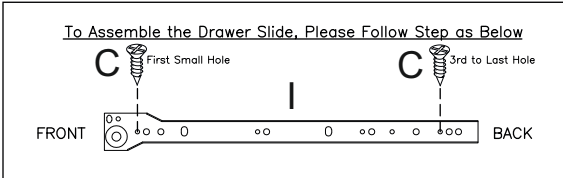
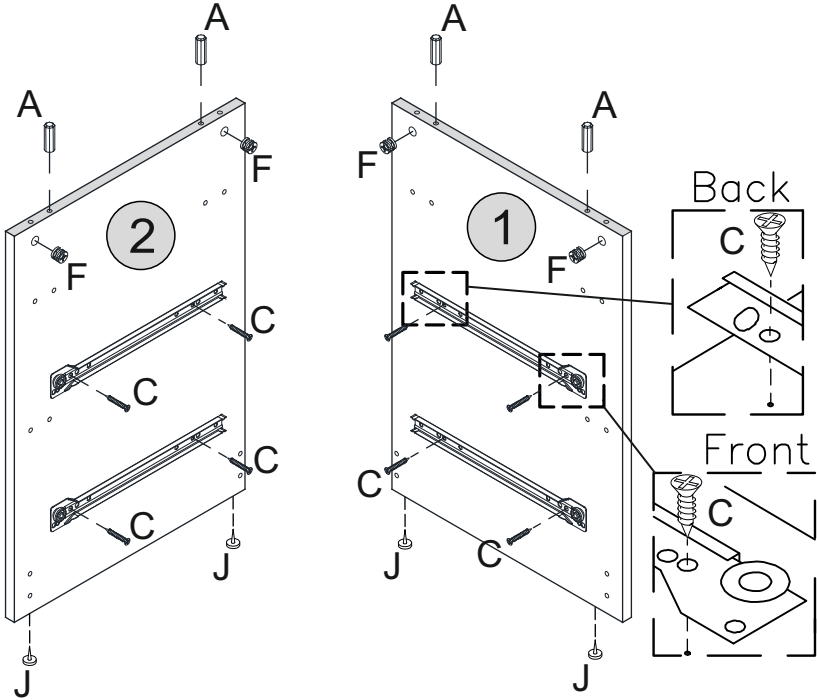
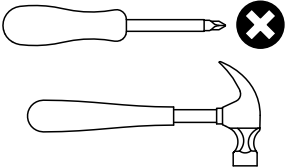

STEP 3

PARTS REQUIRED

2 - LEFT SIDE PANEL x1

4 - SHELF x1

5 - LOWER CROSSBAR x2

6 - MIDDLE CROSSBAR x1

HARDWARE REQUIRED

B  05

L  05

TOOLS REQUIRED

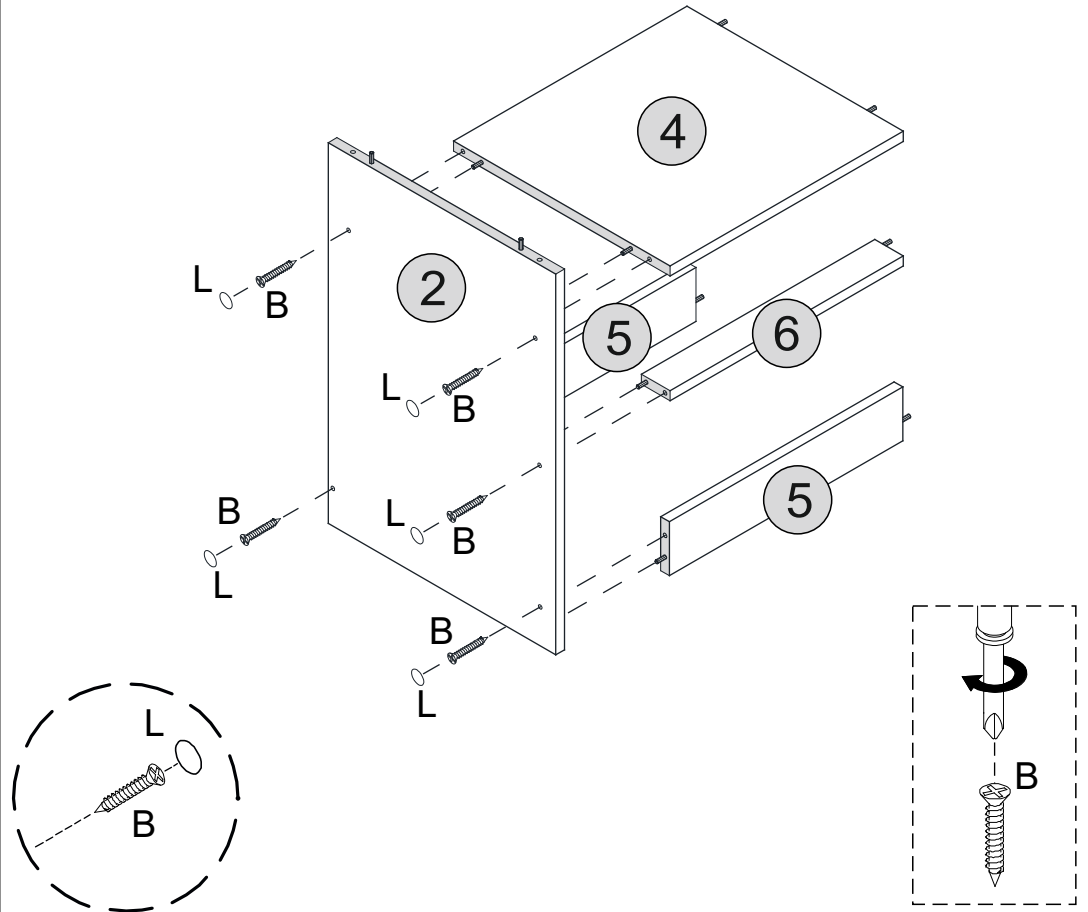
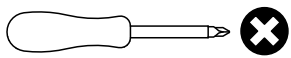

STEP 4

PARTS REQUIRED

1 - RIGHT SIDE PANEL x1

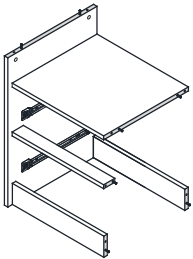

HARDWARE REQUIRED

B  05

L  05

TOOLS REQUIRED

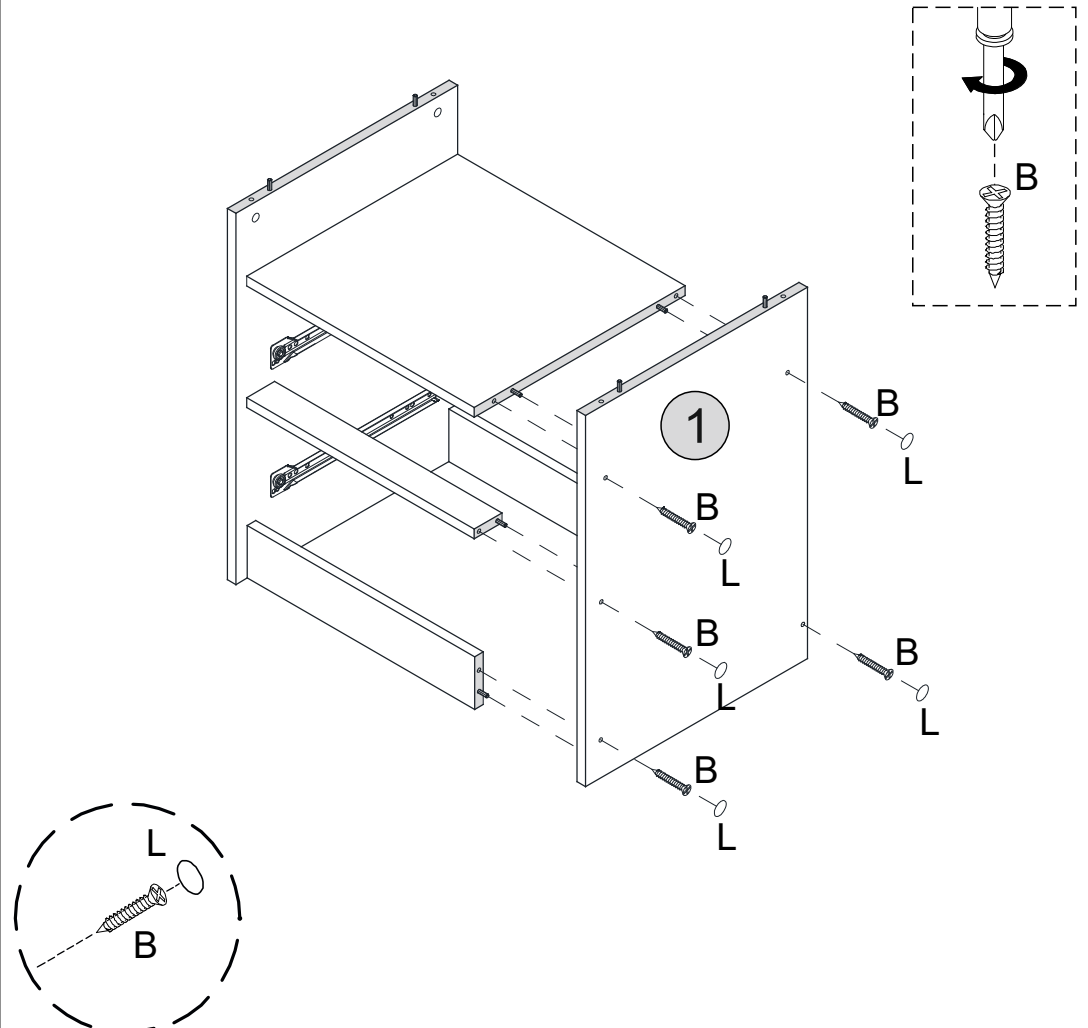
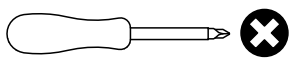

STEP 5

PARTS REQUIRED

1 - TOP PANEL x1

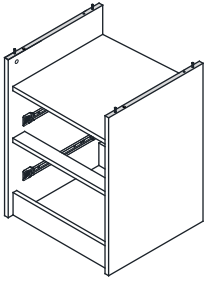

HARDWARE REQUIRED

TOOLS REQUIRED

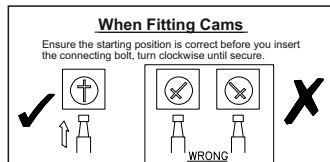
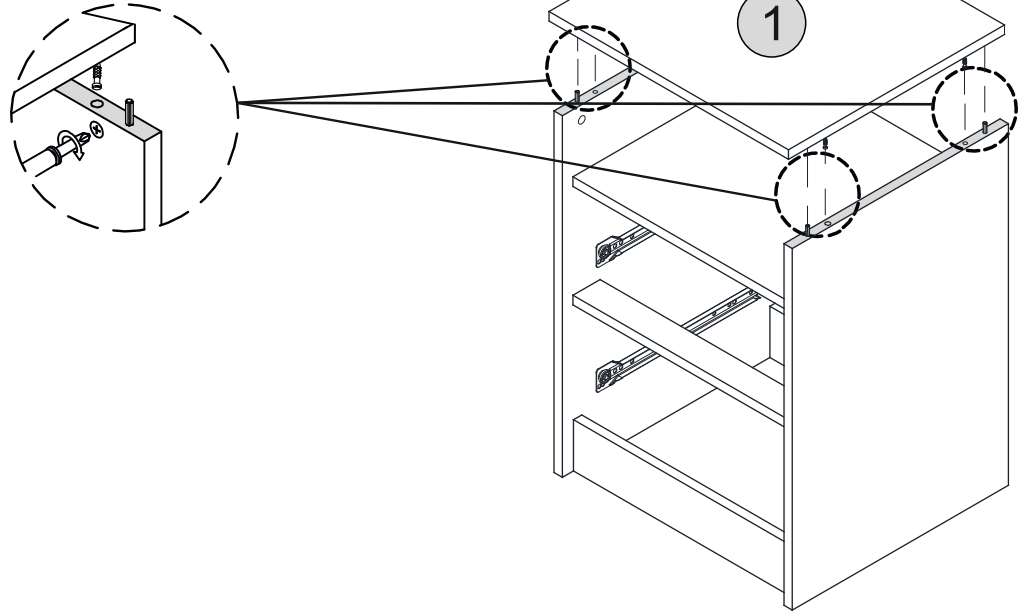
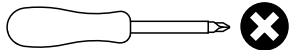

STEP 6

PARTS REQUIRED

13 - BACK PANEL (SMALL) x1

14 - BACK PANEL x1

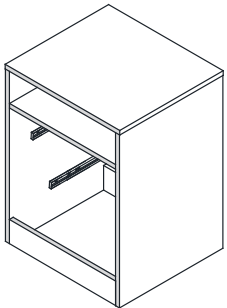

HARDWARE REQUIRED

K  20

TOOLS REQUIRED

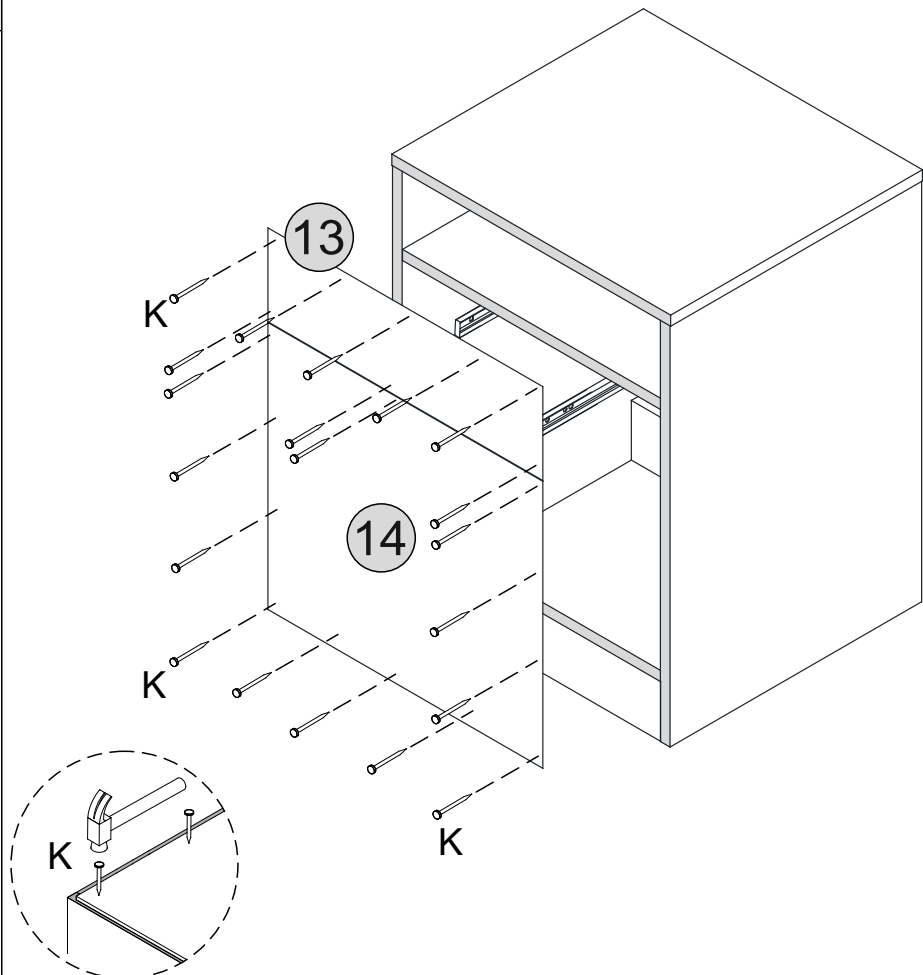
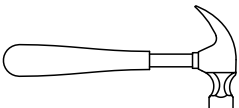



STEP 7

PARTS REQUIRED

7 - TOP DRAWER FRONT	x1
8 - BOTTOM DRAWER FRONT	x1
9 - RIGHT DRAWER SIDE	x2
10 - LEFT DRAWER SIDE	x2

HARDWARE REQUIRED

A		08
E		04
F		04

TOOLS REQUIRED

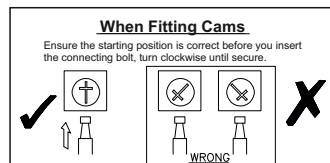
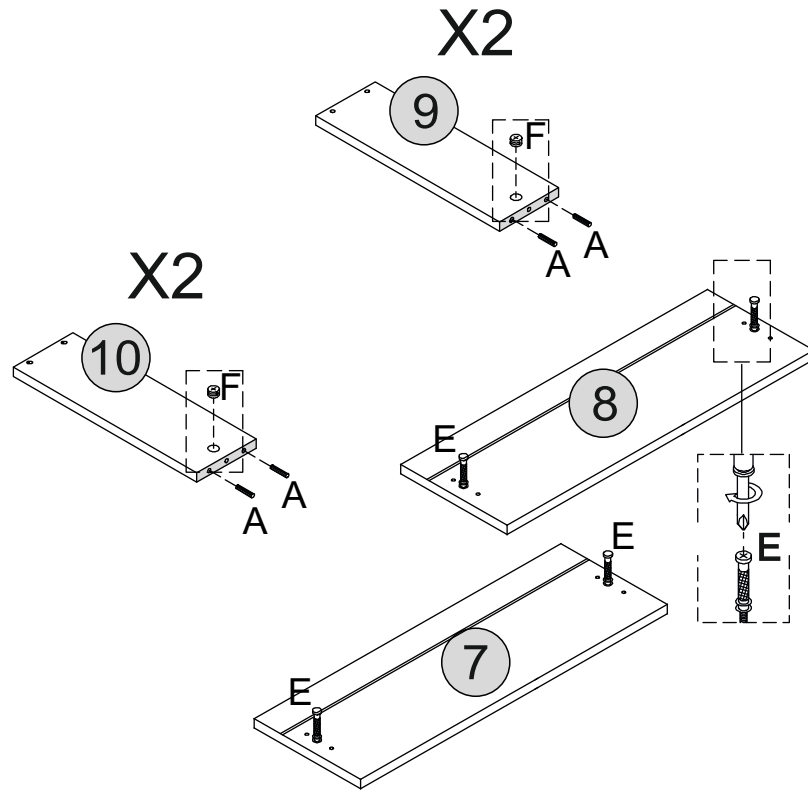
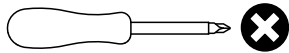

STEP 8

PARTS REQUIRED

9 - RIGHT DRAWER SIDE	x2
10 - LEFT DRAWER SIDE	x2
11 - DRAWER BACK	x2
12 - DRAWER BASE	x2

HARDWARE REQUIRED

D		08
---	---	----

TOOLS REQUIRED

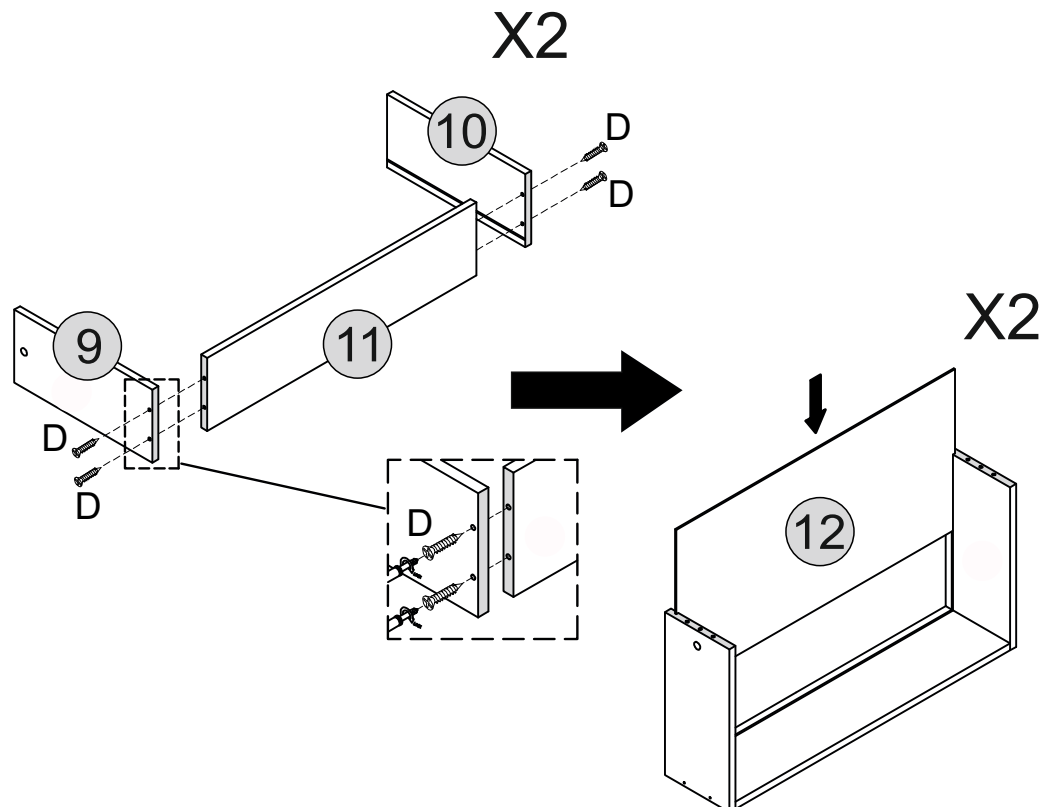
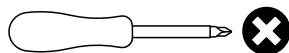

STEP 9

PARTS REQUIRED

7 - TOP DRAWER FRONT x1

8 - BOTTOM DRAWER FRONT x1

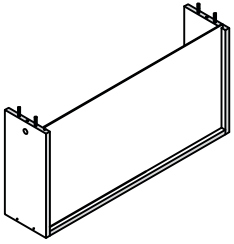

HARDWARE REQUIRED

TOOLS REQUIRED

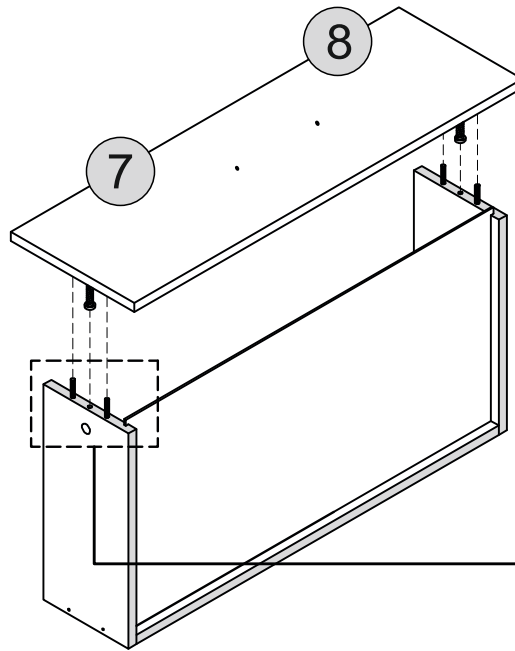
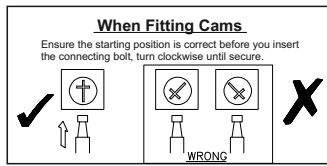
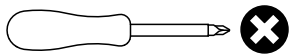

X2

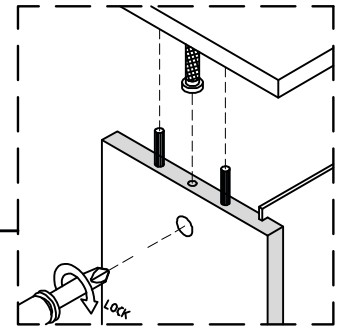

STEP 10

PARTS REQUIRED

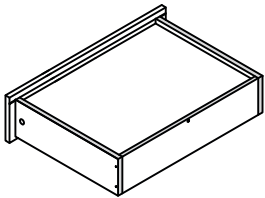

HARDWARE REQUIRED

C  08

I  04

TOOLS REQUIRED

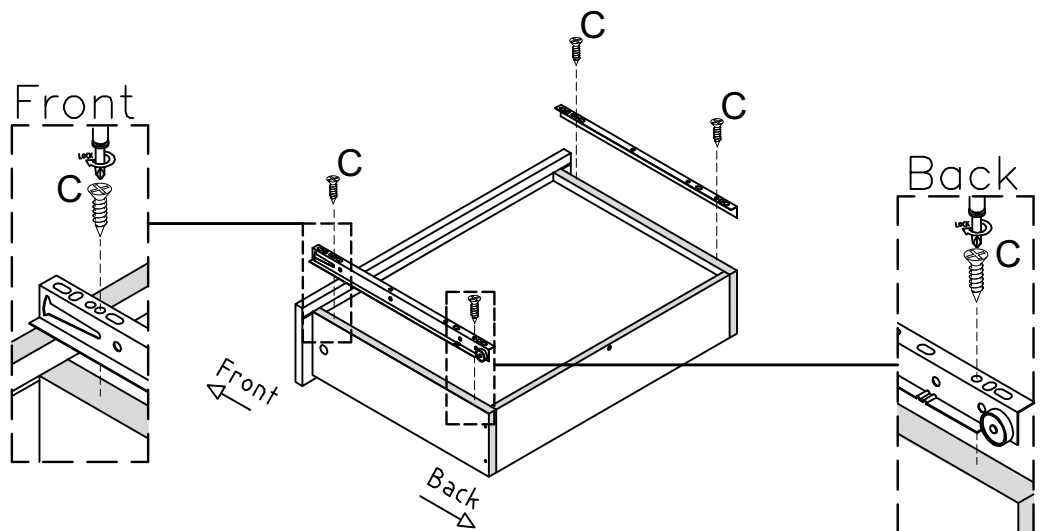
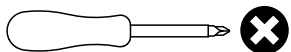

X2

STEP 11

PARTS REQUIRED

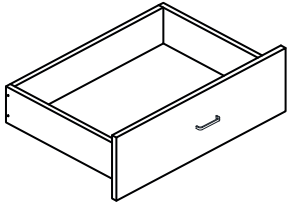

HARDWARE REQUIRED

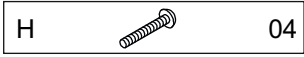

TOOLS REQUIRED

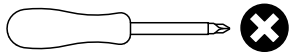

X2

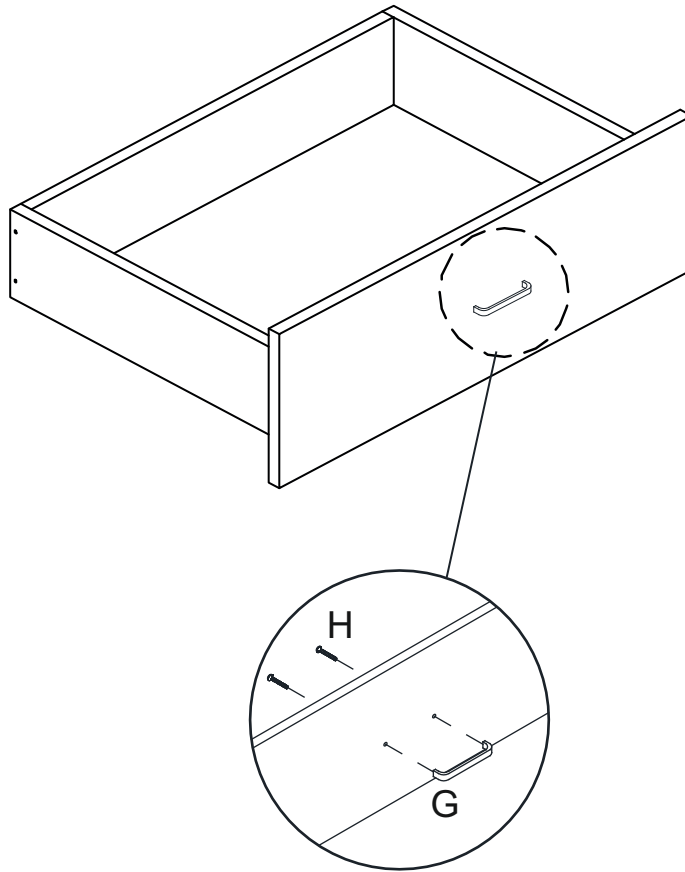

STEP 12

PARTS REQUIRED

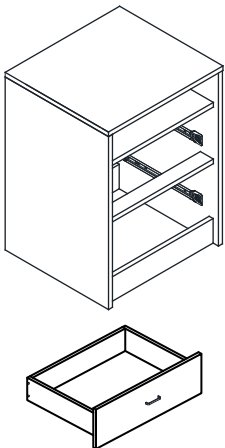

HARDWARE REQUIRED

TOOLS REQUIRED

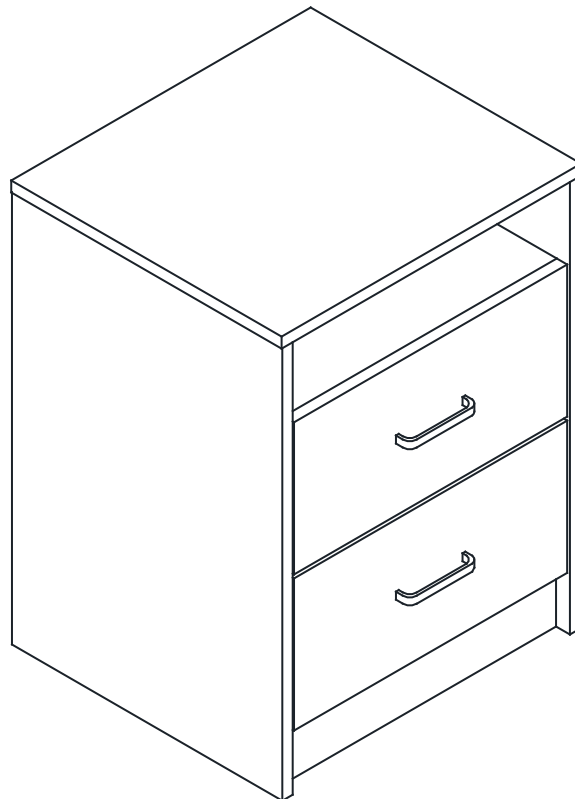

FINISH