

NEVADA 4 DOOR 2 DRAWER WARDROBE ASSEMBLY INSTRUCTIONS

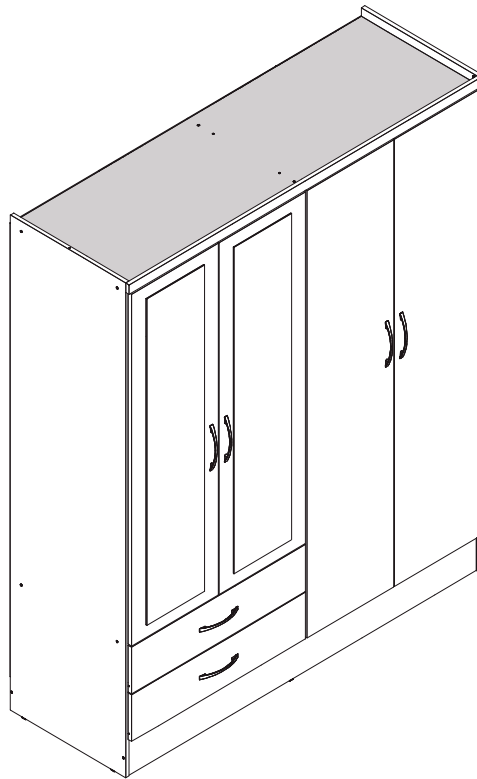

IMPORTANT FOR DOMESTIC USE ONLY PLEASE READ BEFORE YOU CONTINUE FURTHER CARE AND MAINTENANCE

After unpacking this product please keep the original packaging in case it needs to be returned for any reason.



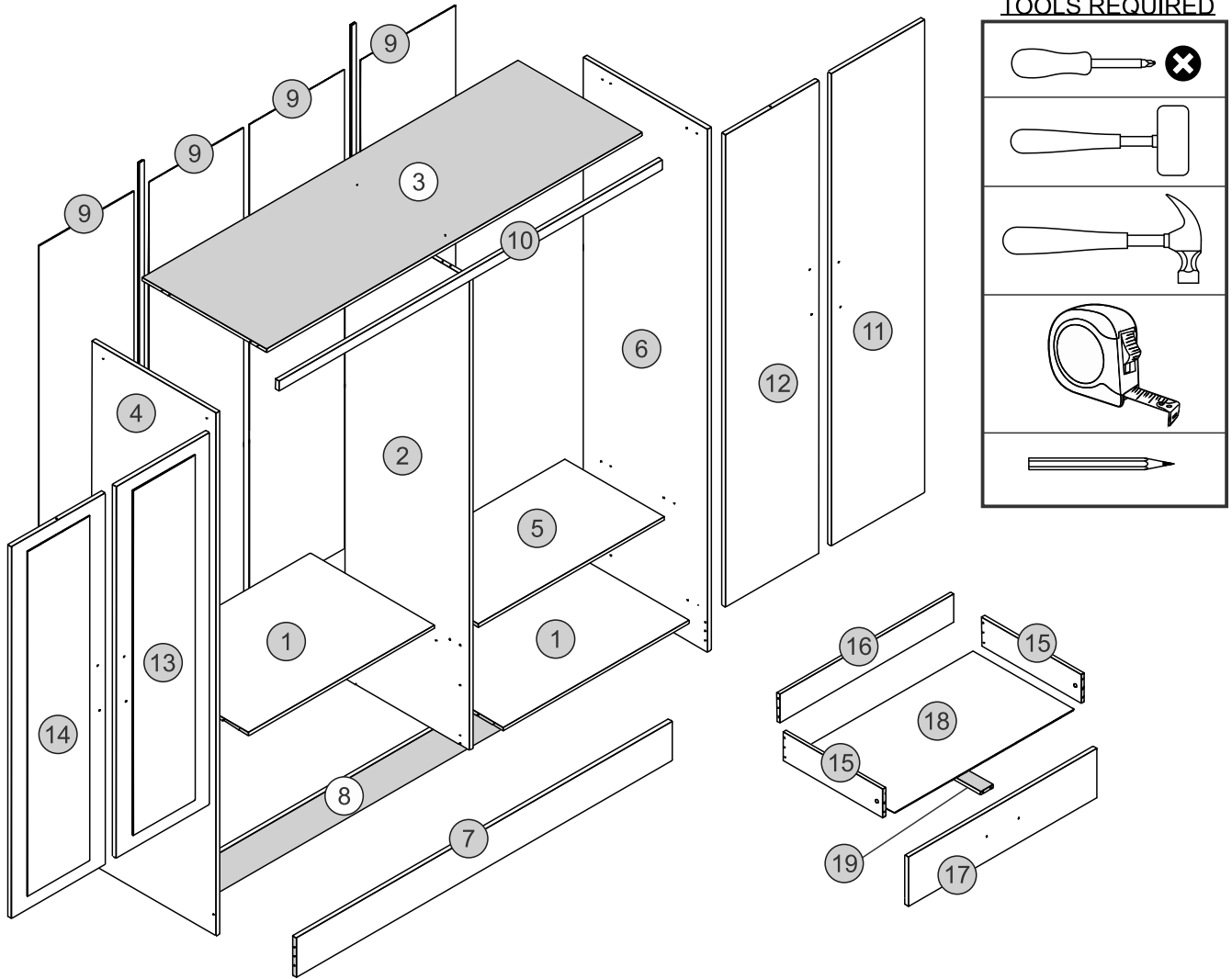





- Please ensure all fittings and parts are present before commencing with assembly.
- Never drag or push products as this could cause damage to the joints making it inferior.
- We strongly recommend that you keep children away from your work area.
- We recommend that you lay a blanket or sheet on the floor to avoid damage to both your floor and the product.
- Assemble this product as close to its final position as possible.
- Do not place this product next to a radiator or in direct sunlight.
- Do not drag or push items across your high gloss furniture as this may cause the surface to scratch
- Wood is a natural product and may expand if subjected to damp and may shrink or crack if subjected to heat. Therefore it is recommended that room temperature is maintained, with no sudden temperature fluctuations.
- Make sure any spillage is wiped off immediately.
- Do not place hot or chilled items directly on to the surface, use a place mat or marking will occur.
- For general cleaning use a soft cotton or micro fibre cloth, and do not use detergents of any kind.
- From time to time it may be necessary to tighten fittings, regular inspections should be carried out.
- Do not place on a wet or damp floor as staining may occur to your floor.

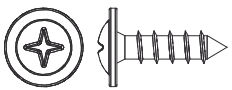
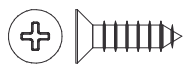
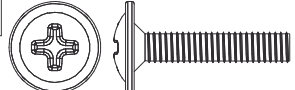

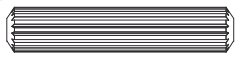
Please Note:
The below parts have all been stamped with the part number to help identify them during assembly.

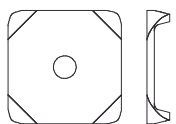
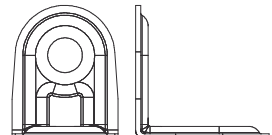
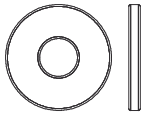
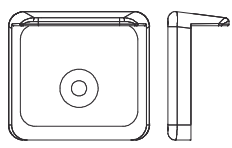
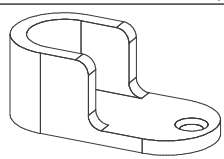
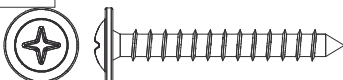
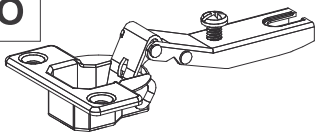
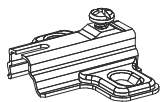
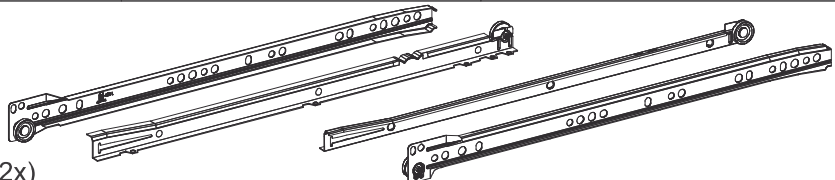
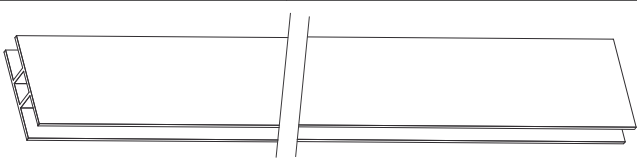
Part Number	Part Description	Quantity	Carton
01	Base Panel	2	1/3
02	Division Panel	1	2/3
03	Top Panel	1	2/3
04	Left Side Panel	1	1/3
05	Shelf	1	1/3
06	Right Side Panel	1	1/3
07	Front Baseboard	1	2/3
08	Back Baseboard	1	2/3
09	Back Panel	4	2/3
10	Frame	2	2/3
11	Right Large Door	2	3/3
12	Left Large Door	1	3/3
13	Right Small Door	1	3/3
14	Left Small Door	1	3/3
15	Drawer Side	4	1/3
16	Drawer Back Panel	2	1/3
17	Drawer Front	2	2/3
18	Drawer Bottom	2	2/3
19	Drawer Bottom Support Bar	2	2/3

FITTINGS LIST

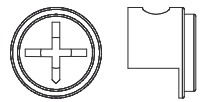
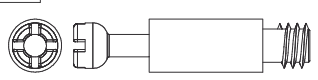
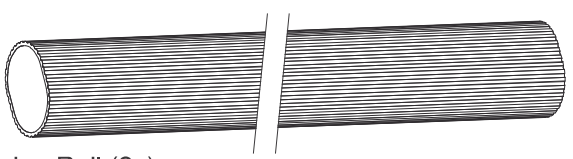
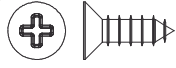
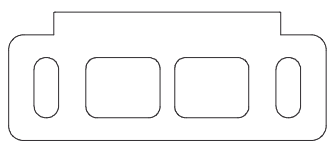
<p>A</p>  <p>Flat Head Screw Ø6,0 x 10mm (8x)</p> <p>+1</p>	<p>B</p>  <p>Flan Head Screw Ø4,0 x 14mm (12x)</p> <p>+2</p>	<p>C</p>  <p>Flat Head Screw Ø4,0 x 14mm (68x)</p> <p>+2</p>	<p>D</p>  <p>Flan Head Screw Ø4,0 x 20mm (12x)</p> <p>+2</p>
<p>E</p>  <p>Flat Head Screw Ø3,5 x 40mm (4x)</p> <p>+1</p>	<p>F</p>  <p>Flat Head Screw Ø4,0 x 50mm (26x)</p> <p>+2</p>		<p>G</p>  <p>Dowel Ø6,0 x 30mm (46x)</p> <p>+2</p>
<p>H</p>  <p>Nail 10 x 10 (100x)</p> <p>+2</p>	<p>I</p>  <p>Back Panel Bracket (16x)</p> <p>+2</p>	<p>J</p>  <p>'L' Metallic Support (10x)</p> <p>+2</p>	<p>K</p>  <p>Washer (4x)</p> <p>+1</p>
<p>L</p>  <p>Plastic Foot (6x)</p> <p>+1</p>	<p>M</p>  <p>Hanging Rail Support (4x)</p>	<p>N</p>  <p>Flan Head Screw Ø3,5 x 30mm (2x)</p> <p>+1</p>	<p>O</p>  <p>Hinge (12x)</p>
<p>P</p>  <p>Hinge Plate (12x)</p>	<p>Q</p>  <p>Drawer Runners (2x)</p>		
<p>R</p>  <p>Back Panel Strip (2x)</p>	<p>S</p>  <p>Strap (2x)</p>	<p>T</p>  <p>Handle (6x)</p>	
<p>U</p>  <p>Hole Plugs (26x)</p> <p>+2</p>	<p>V</p>  <p>Glue (2x)</p>	<p>W</p>  <p>Cam Nut (4x)</p> <p>+1</p>	<p>X</p>  <p>Cam Bolt (4x)</p> <p>+1</p>
<p>Y</p>  <p>Hanging Rail (2x)</p>	<p>Z</p>  <p>Flat Head Screw Ø4,0 x 12mm (28x)</p> <p>+2</p>	<p>A1</p>  <p>Door Support (4x)</p>	

TIPS FOR FITTINGS CAM-LOCKS

<p>B1</p>  <p>Hole Plugs Líneo 19mm (4x)</p> <p>+2</p>
--

WHEN FITTING CAM NUT, ENSURE STARTING POSITION IS CORRECT BEFORE YOU INSERT CONNECTING CAM BOLT TURN CLOCKWISE UNTIL SECURE

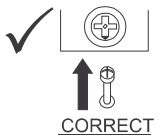

✓

↑

CORRECT

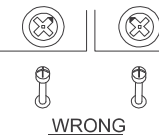

✗

↑

WRONG

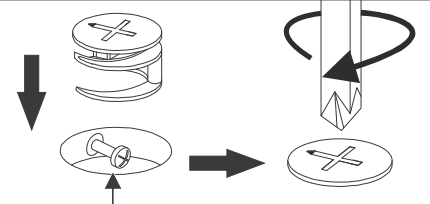

Cam bolt head needs to be in centre

CAMBOLT
Tighten until shoulder in flush with panel. Do not overtighten or undertighten (see example beside)



Shoulder

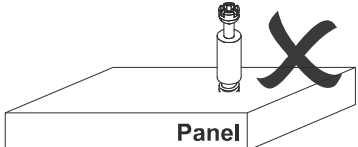

Panel

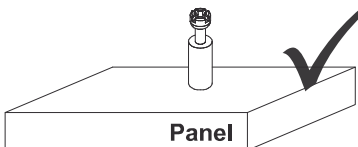

Panel

STEP 1

PARTS REQUIRED

4 - LEFT SIDE PANEL x1

HARDWARE REQUIRED

C  08
Ø4,0 x 14mm

H  02

L  02

M  01

P  03

TOOLS REQUIRED

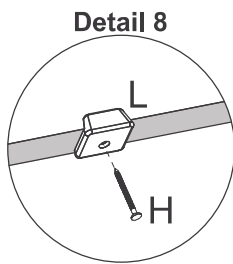
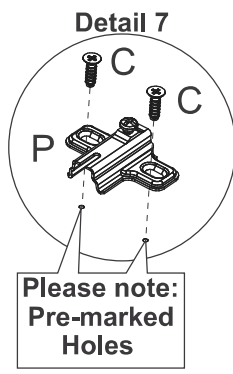
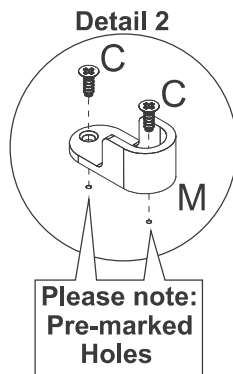
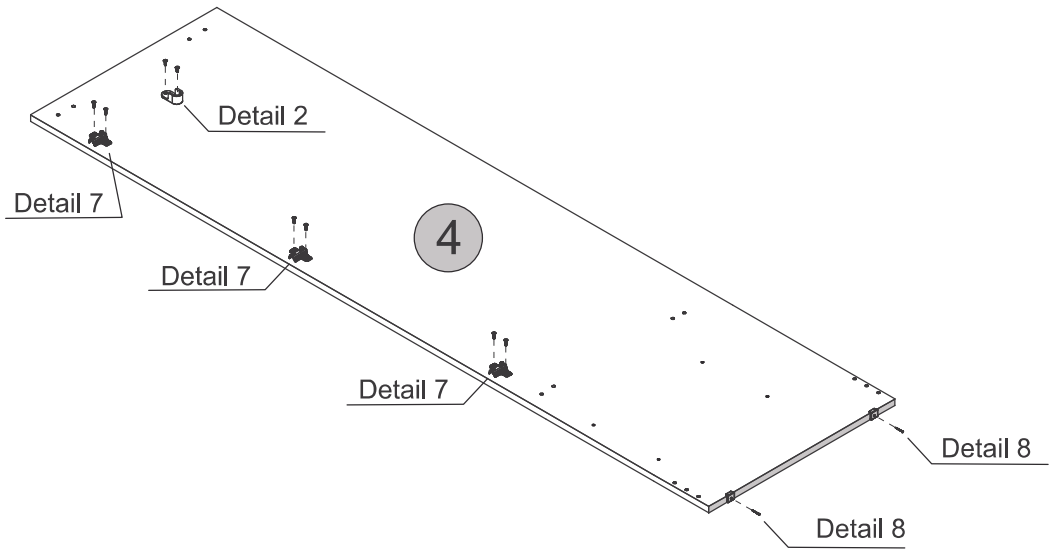
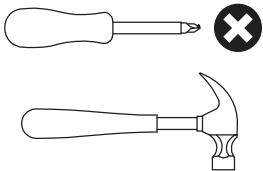



STEP 2

PARTS REQUIRED

4 - LEFT SIDE PANEL x1

HARDWARE REQUIRED

A  04
Ø6,0 x 10mm

Q  02

TOOLS REQUIRED

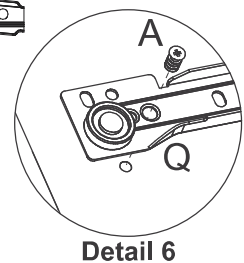
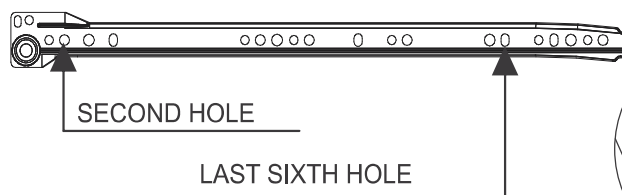
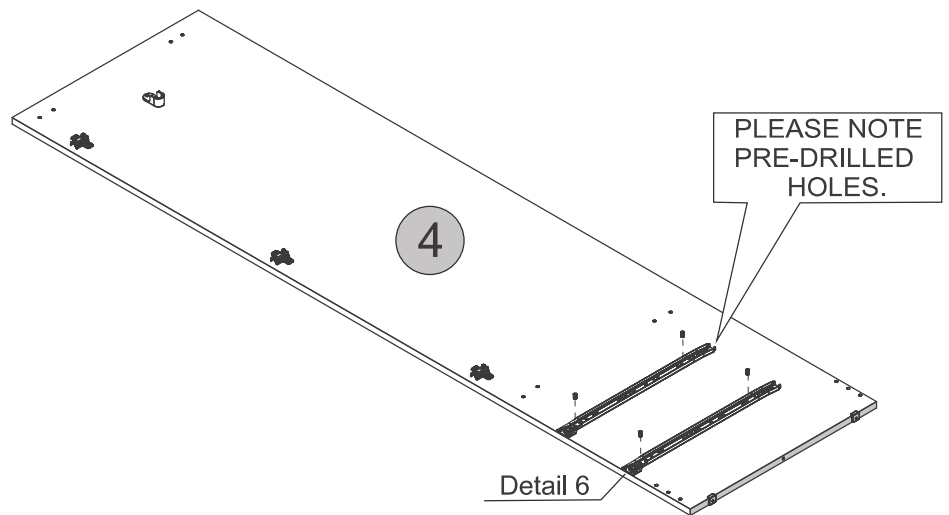
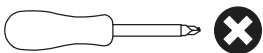

STEP 3

PARTS REQUIRED

2 - DIVISION PANEL x1

HARDWARE REQUIRED

C  08
Ø4,0 x 14mm

G  02
Ø6,0 x 30mm

M  01

P  03

V  01
Glue

TOOLS REQUIRED

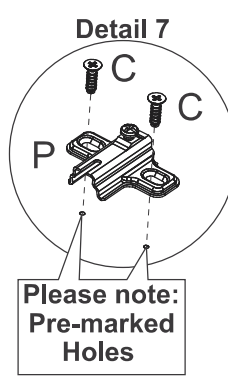
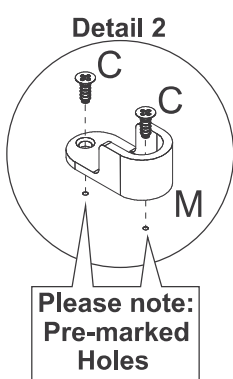
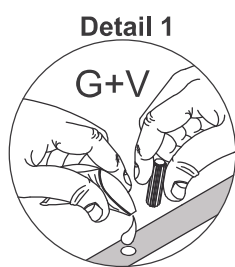
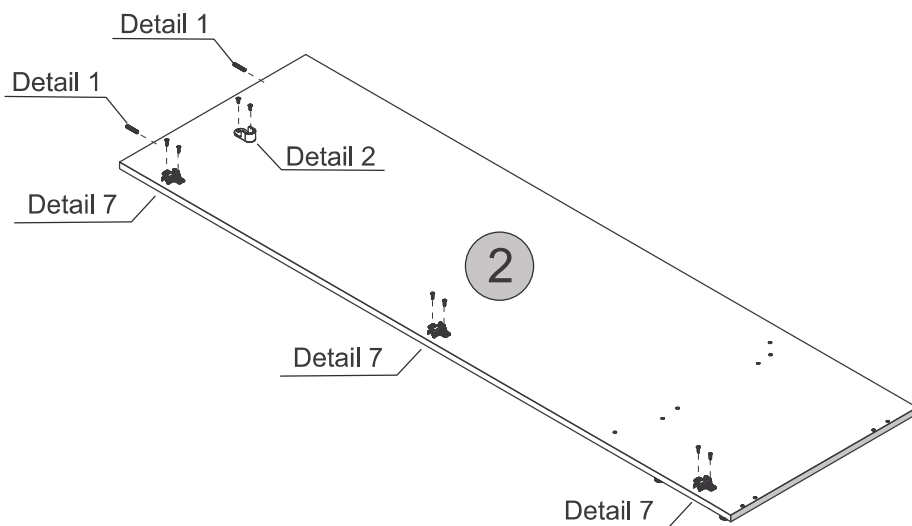
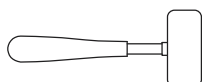
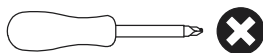

STEP 4

PARTS REQUIRED

2 - DIVISION PANEL x1

HARDWARE REQUIRED

C  08
Ø4,0 x 14mm

M  01

P  03

TOOLS REQUIRED

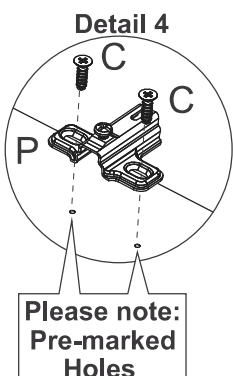
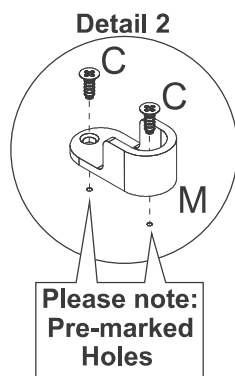
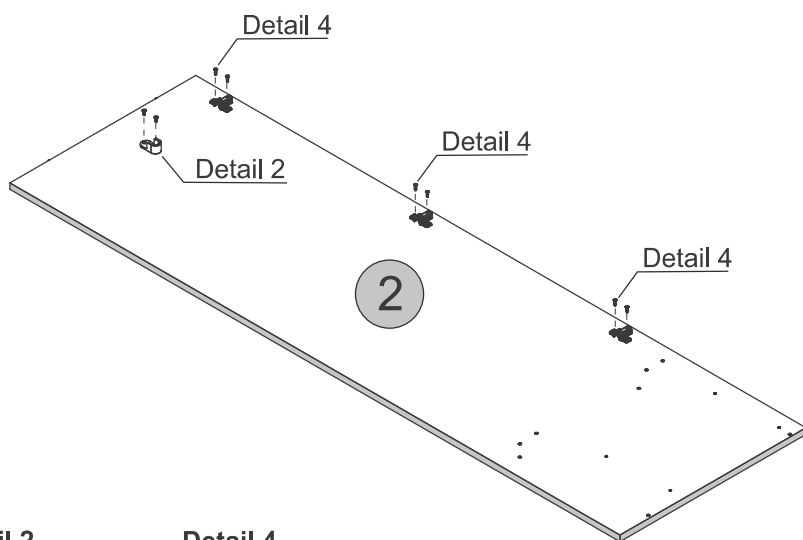
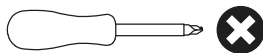

STEP 5

PARTS REQUIRED

2 - DIVISION PANEL x1

HARDWARE REQUIRED

A  04
Ø6,0 x 10mm

Q  02
Right

TOOLS REQUIRED

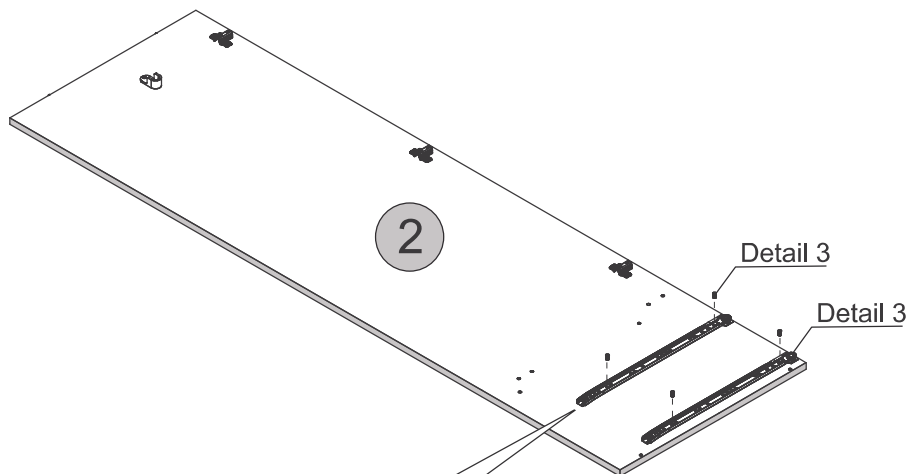
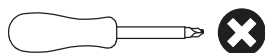

PLEASE NOTE
PRE-DRILLED
HOLES.

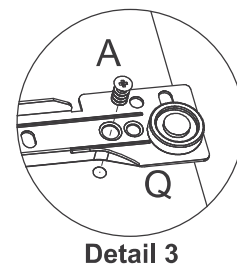
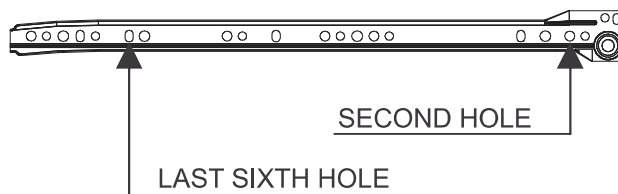

STEP 6

PARTS REQUIRED

6 - RIGHT SIDE PANEL x1

HARDWARE REQUIRED

C  08
Ø4,0 x 14mm

H  02

L  02

M  01

P  03

TOOLS REQUIRED

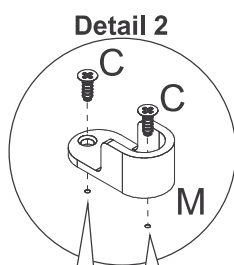
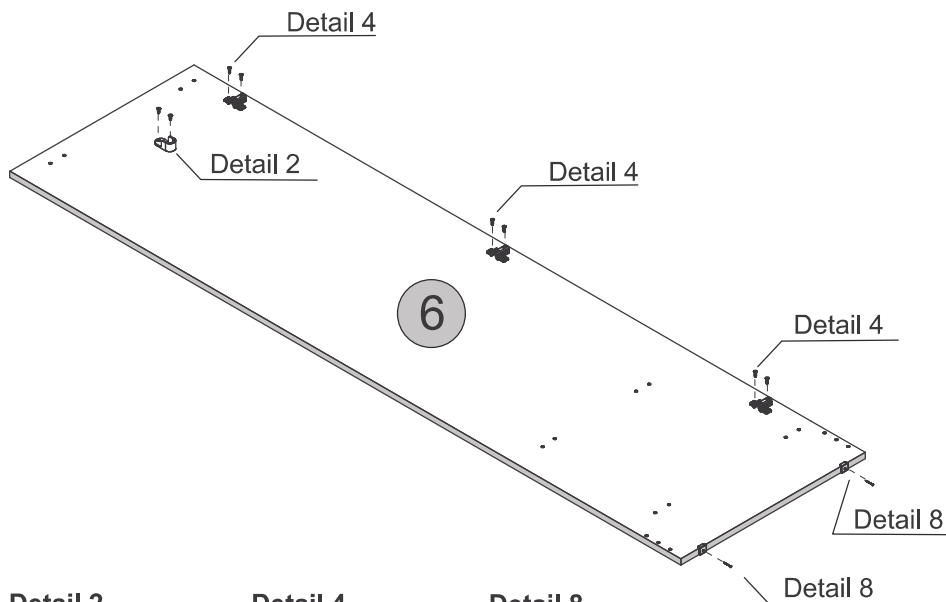
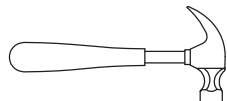
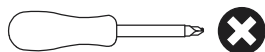

Please note:
Pre-marked
Holes

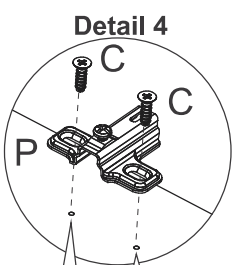

Please note:
Pre-marked
Holes

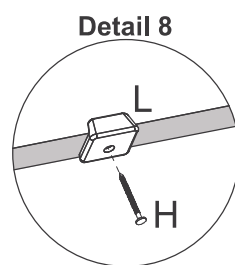





STEP 7

PARTS REQUIRED

- 7 - FRONT BASEBOARD x1
- 8 - BACK BASEBOARD x1

HARDWARE REQUIRED

- H  02
- L  02
- G  Ø6,0 x 30mm 08
- V  01

TOOLS REQUIRED

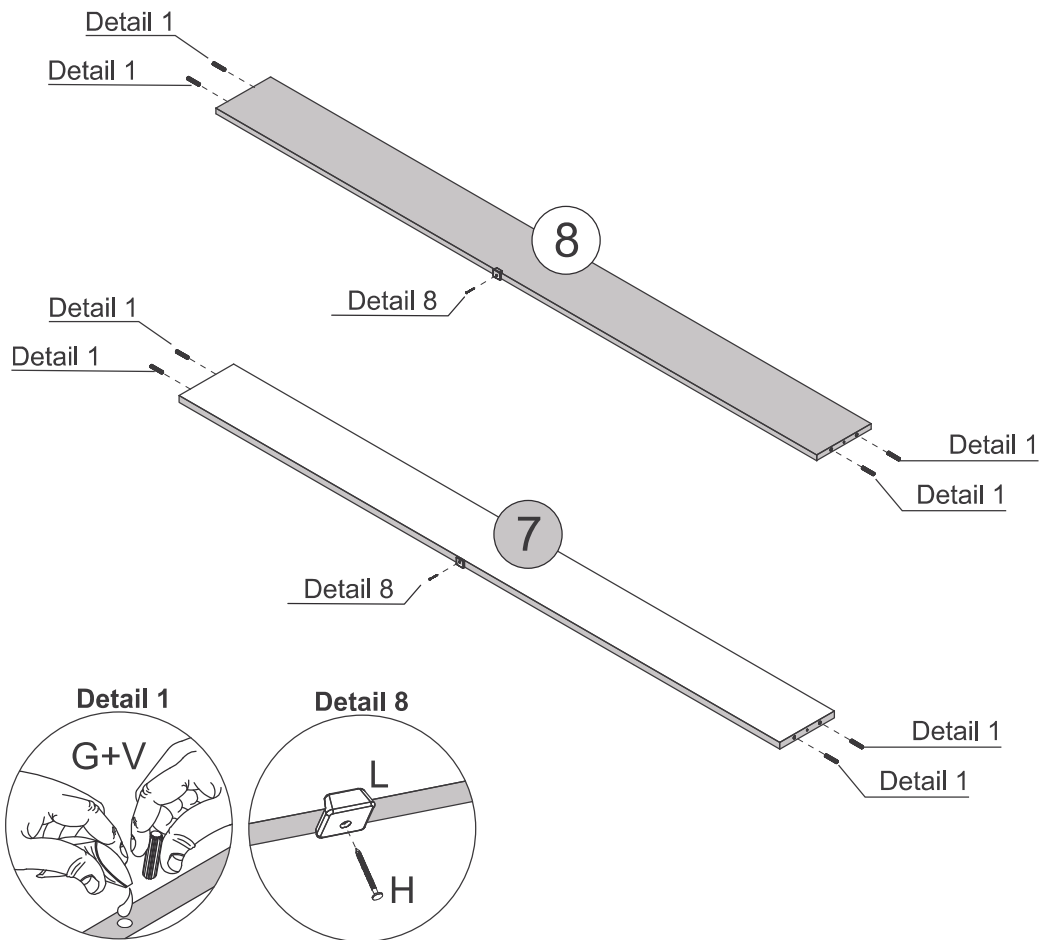
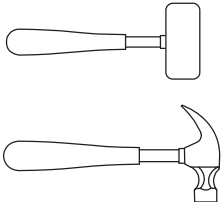





STEP 8

PARTS REQUIRED

- 1 - BASE PANEL x2
- 5 - SHELF x1

HARDWARE REQUIRED

- G  Ø6,0 x 30mm 12
- V  01
- Z  Ø4,0 x 12mm 04
- A1  02

TOOLS REQUIRED

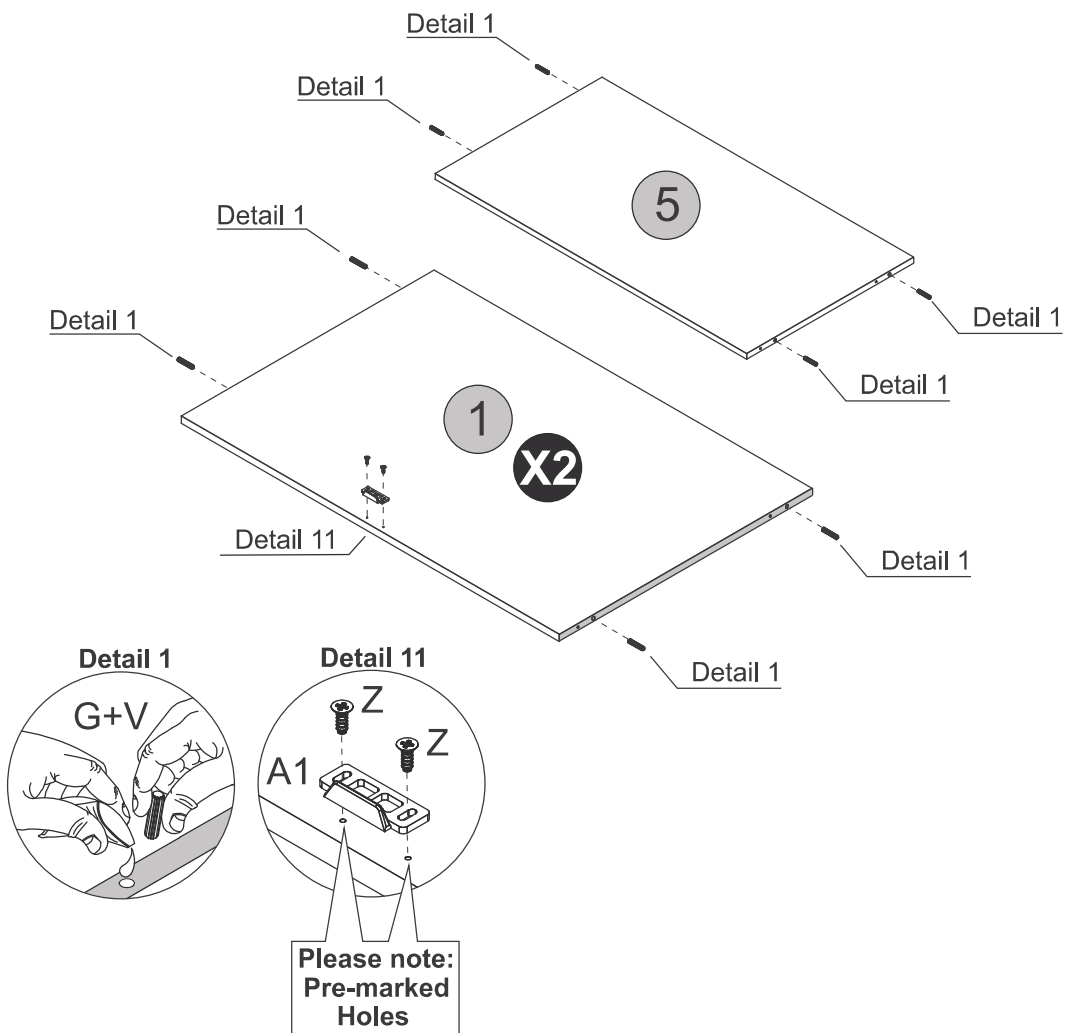
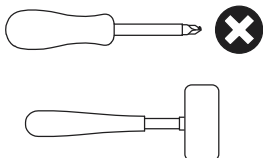

STEP 9

PARTS REQUIRED

3 - TOP PANEL x1

HARDWARE REQUIRED

G  04
Ø6,0 x 30mm

J  04

V  01

Z  08
Ø4,0 x 12mm

A1  02

TOOLS REQUIRED

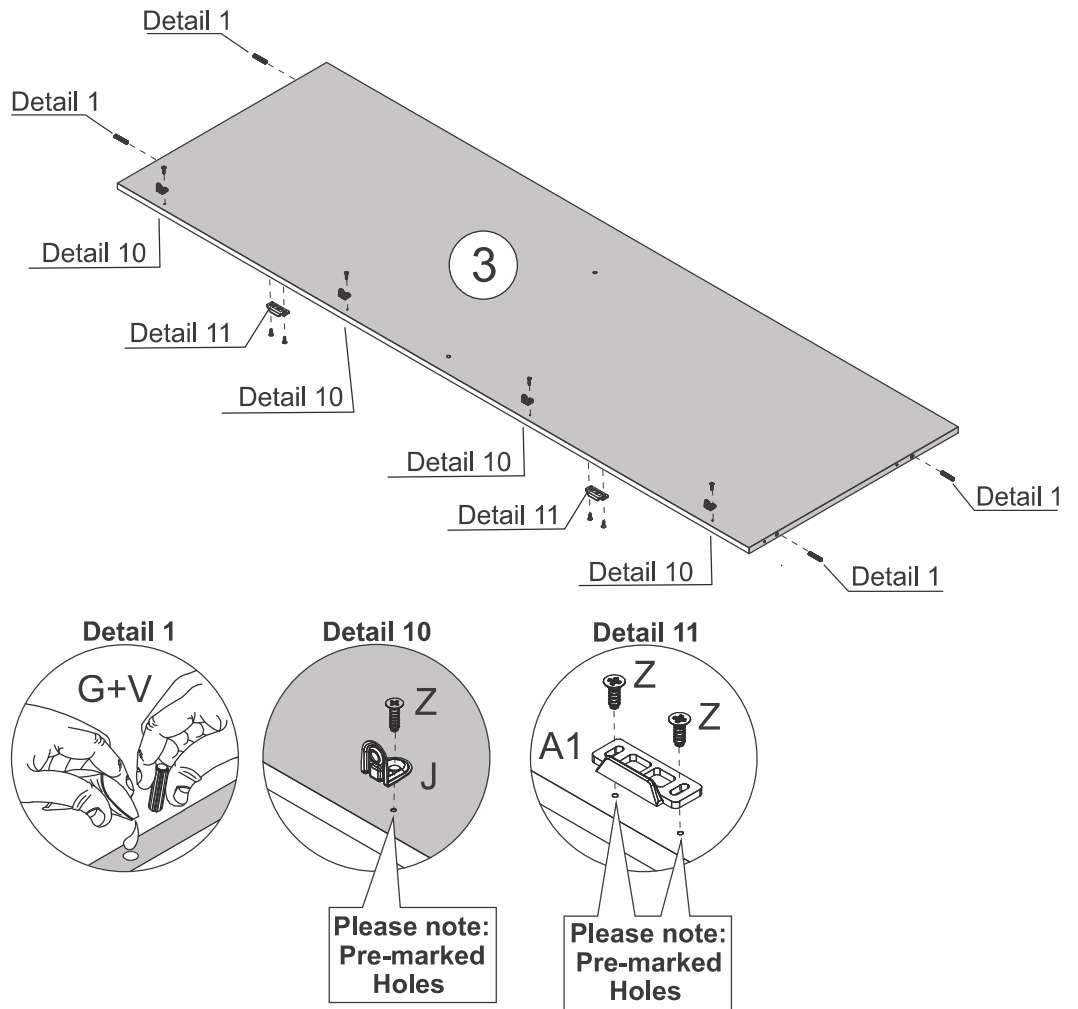
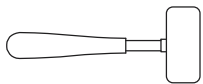
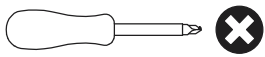

STEP 10

PARTS REQUIRED

1 - BASE PANEL x2

2 - DIVISION PANEL x1

3 - TOP PANEL x1

HARDWARE REQUIRED

F  06
Ø4,0 x 50mm

V  01

TOOLS REQUIRED

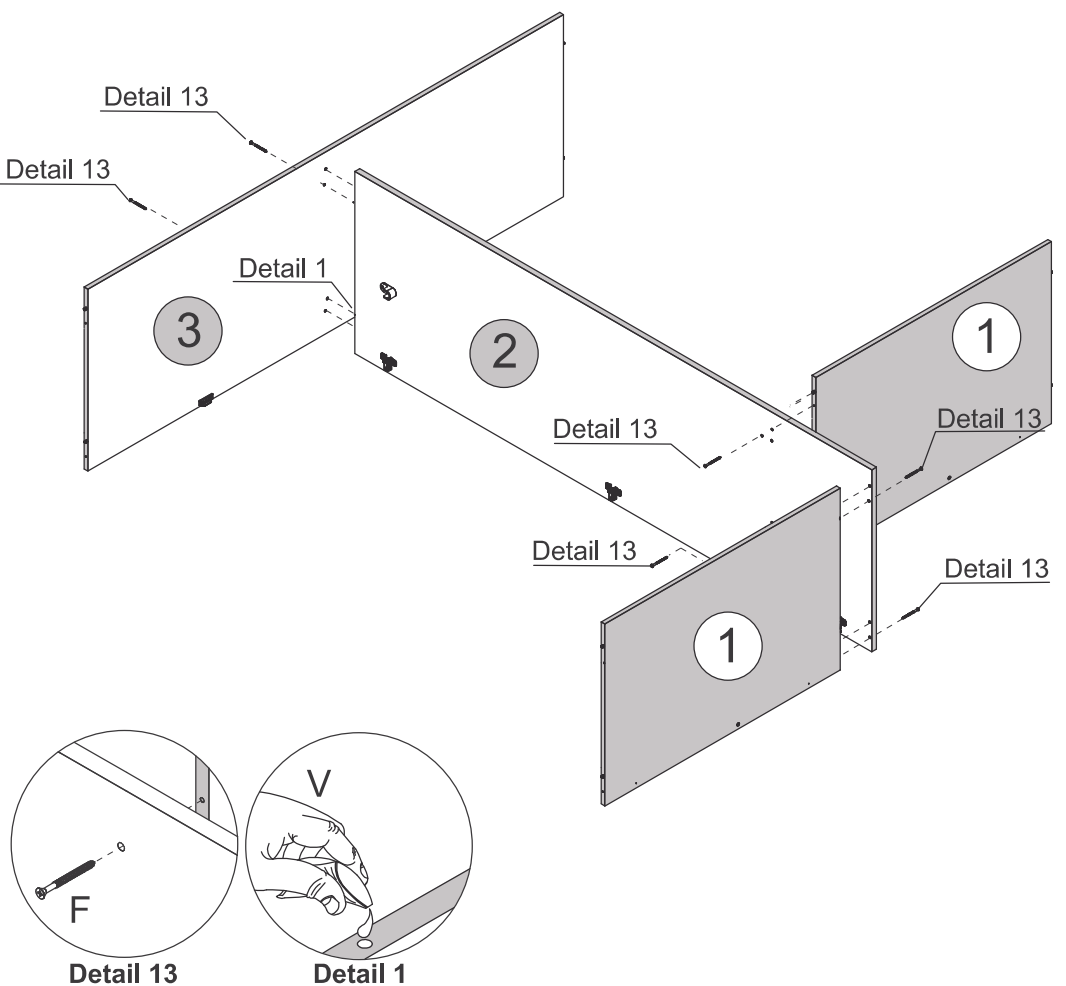
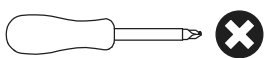

STEP 11

PARTS REQUIRED

4 - LEFT SIDE PANEL x1

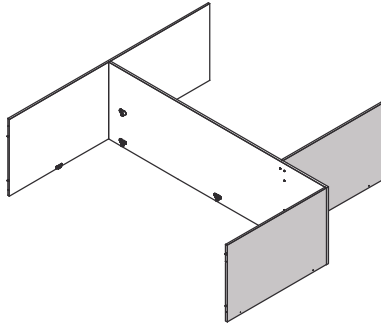

HARDWARE REQUIRED

F  04
Ø4,0 x 50mm

V  01

TOOLS REQUIRED

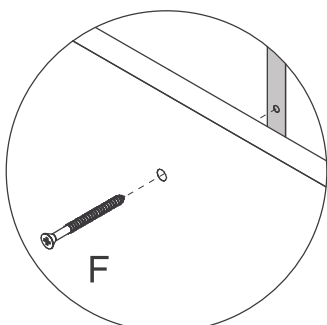
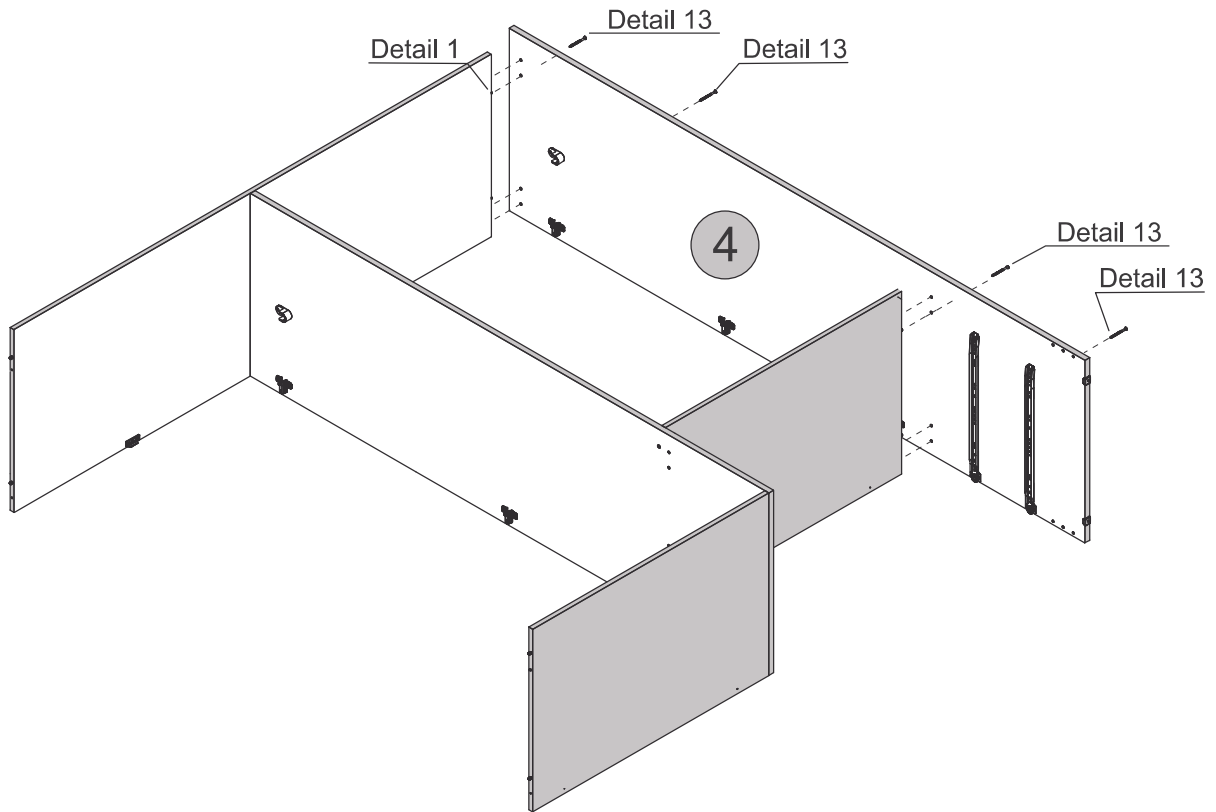
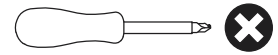

Detail 13

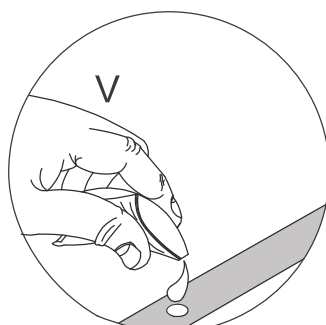



Detail 1

STEP 12

PARTS REQUIRED

5 - SHELF	x1
6 - RIGHT SIDE PANEL	x1
7 - FRONT BASEBOARD	x1
8 - BACK BASEBOARD	x1

HARDWARE REQUIRED

F	 Ø4,0 x 50mm	12
V	 Glue	01

TOOLS REQUIRED

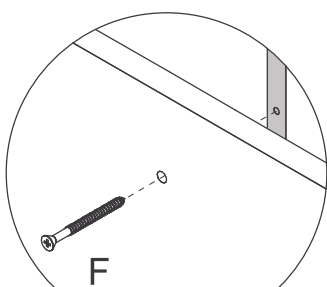
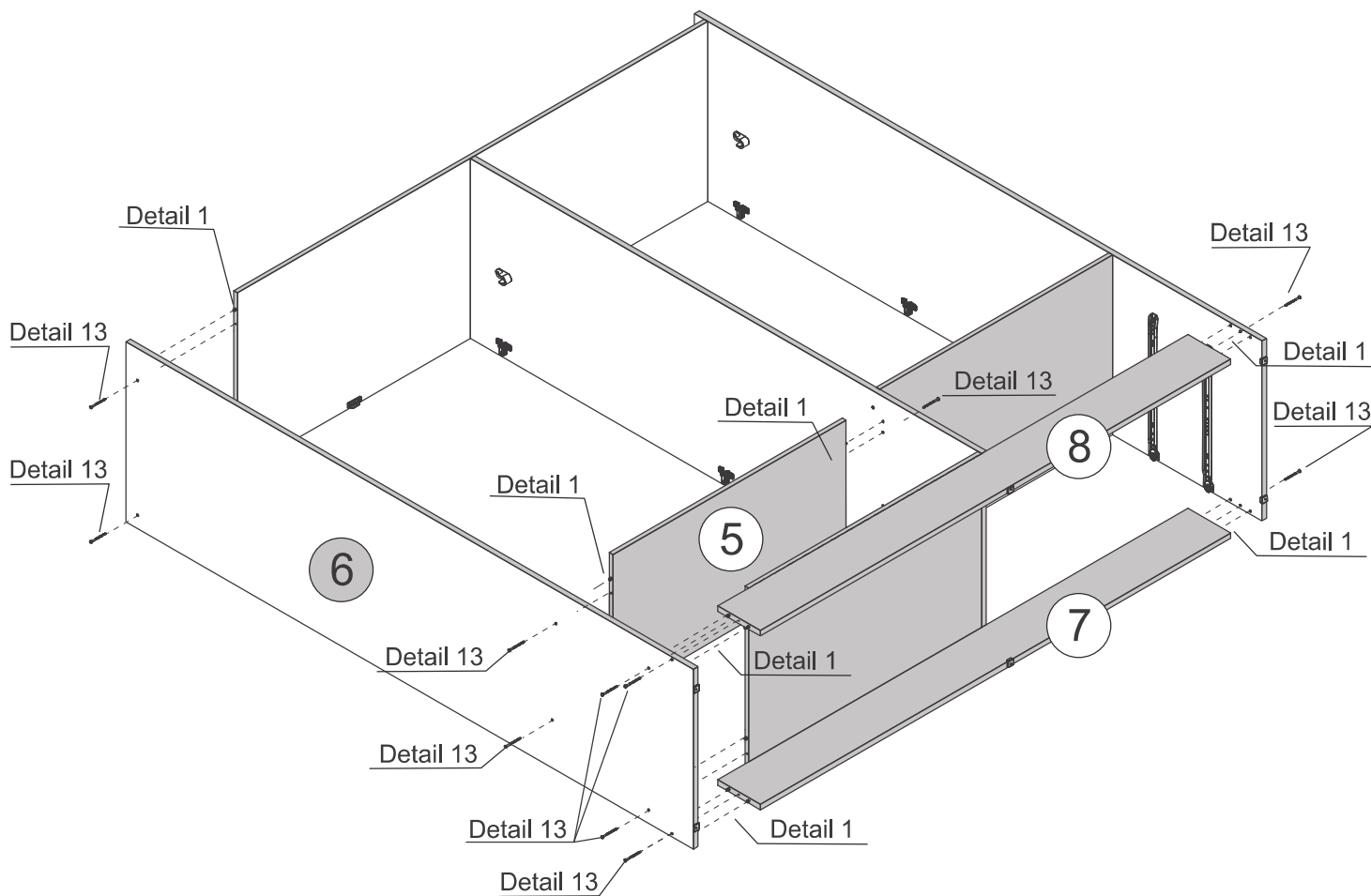
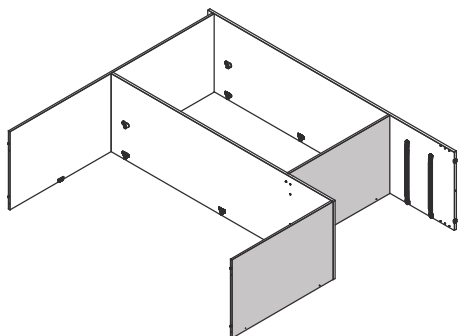
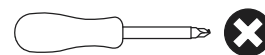

Detail 13

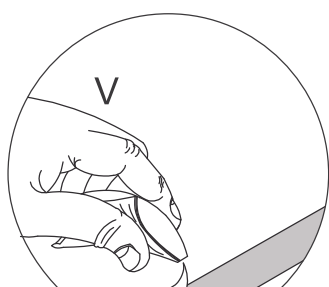



Detail 1

STEP 13

PARTS REQUIRED

9 - BACK PANEL x4

HARDWARE REQUIRED

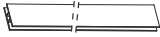
B		12
H		12
R		02

TOOLS REQUIRED

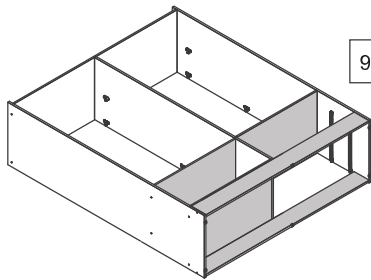
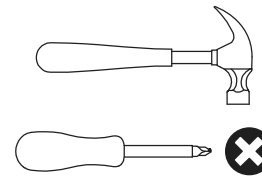

IMPORTANT PLEASE FOLLOW !

Please make sure Part 9 is lined up correctly at the top before placing fitting H into the panel as this can affect the alignment of the doors once assembled.

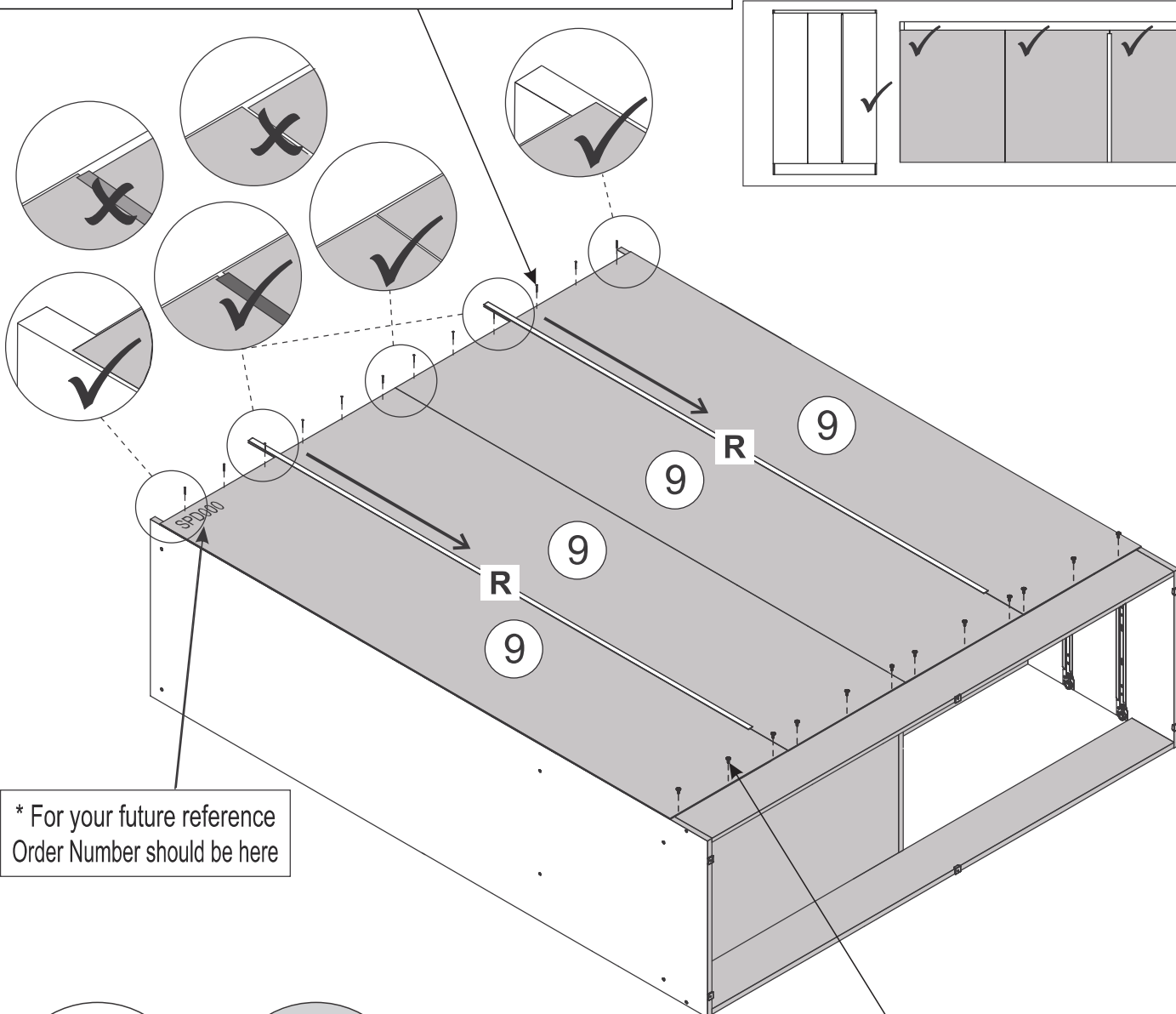
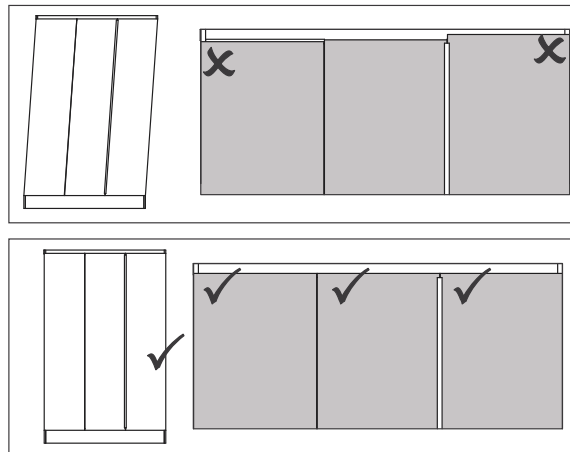

* For your future reference
Order Number should be here

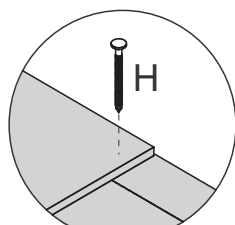

Detail 15

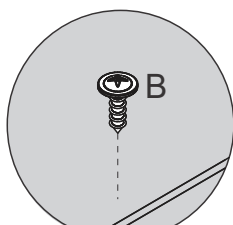

Detail 16

IMPORTANT PLEASE FOLLOW !



Please make sure Part 9 isn't overhanging at the sides before you screw fitting B into the plinth.

STEP 14

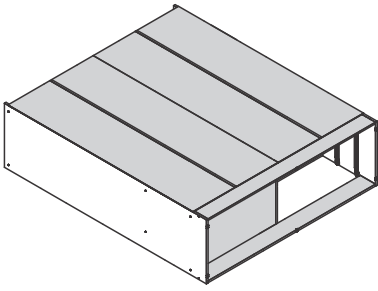
PARTS REQUIRED



HARDWARE REQUIRED

H	 10 x 10	50
I		16

TOOLS REQUIRED

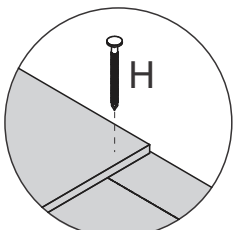
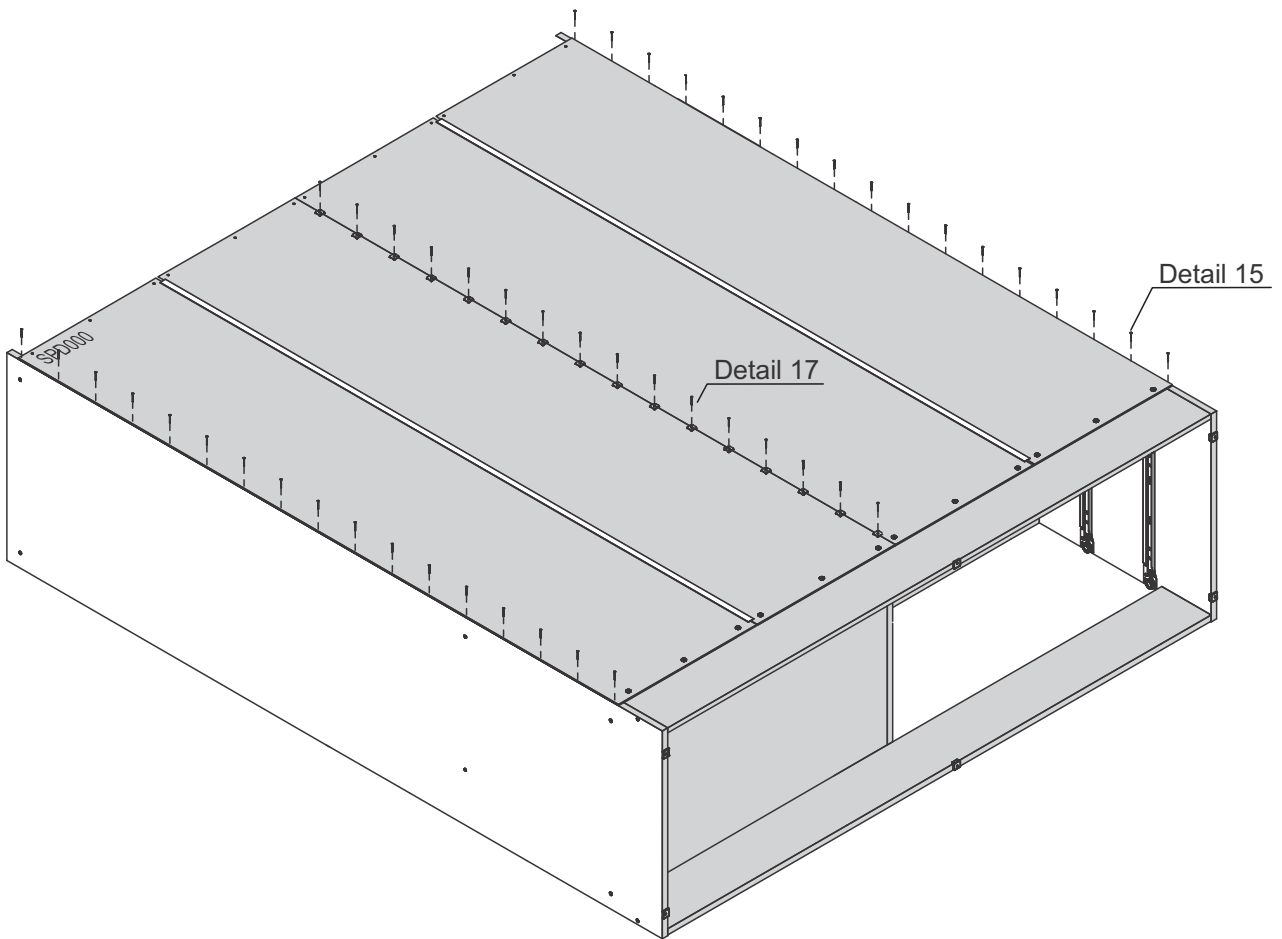
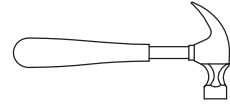

Detail 15

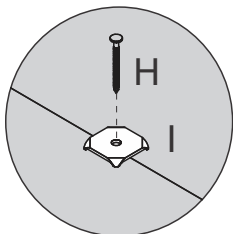

Detail 17

STEP 15

PARTS REQUIRED

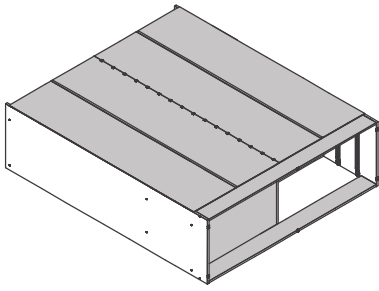

HARDWARE REQUIRED

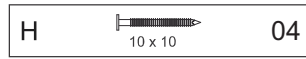

TOOLS REQUIRED

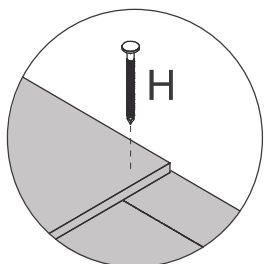
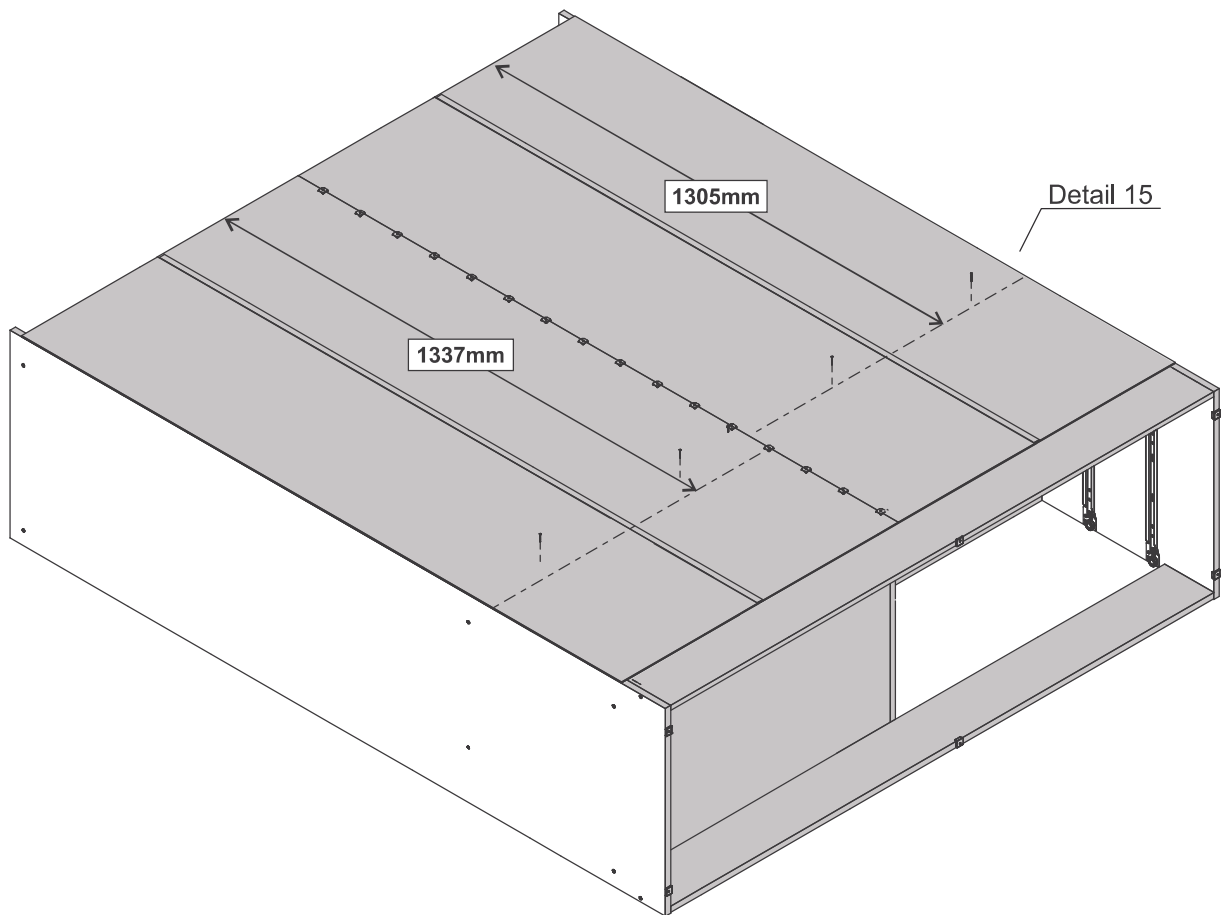
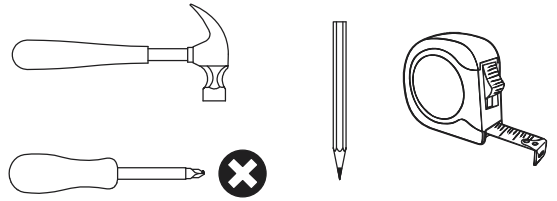

Detail 15

STEP 16

PARTS REQUIRED

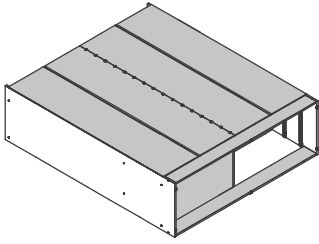

HARDWARE REQUIRED

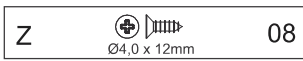

TOOLS REQUIRED

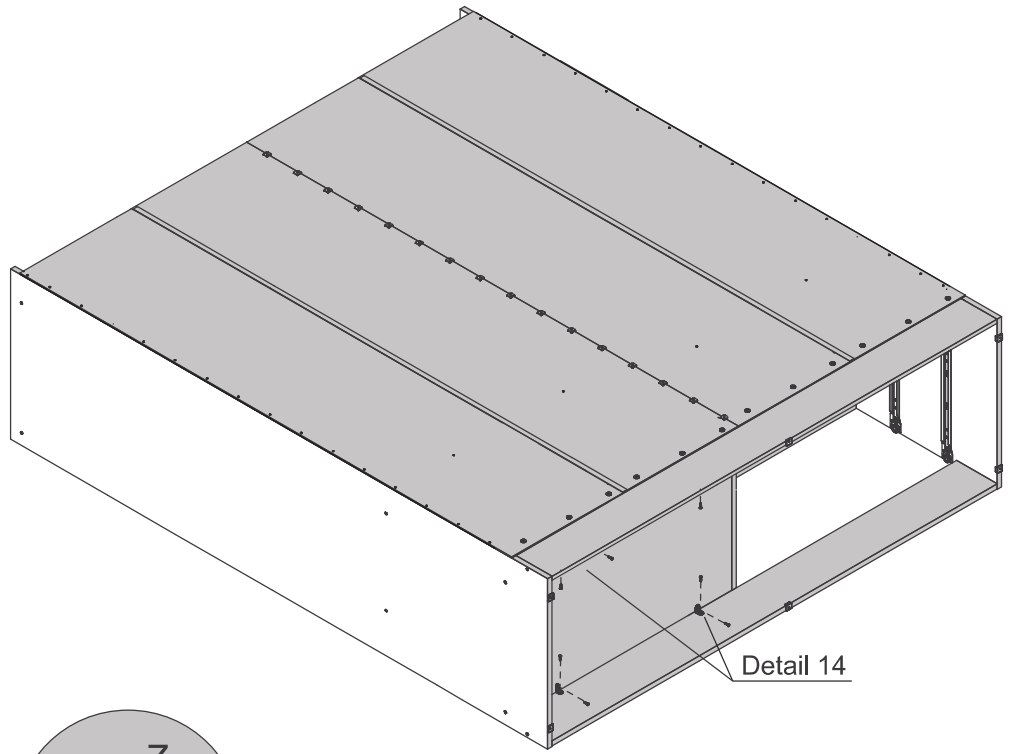
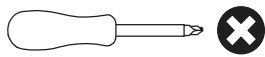

Detail 14

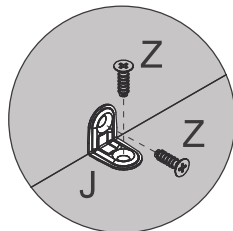

Detail 14

STEP 17

PARTS REQUIRED

10 - FRAME	x1
------------	----

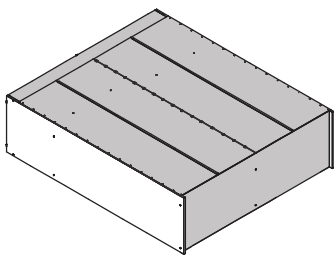

HARDWARE REQUIRED

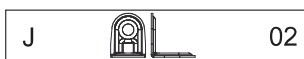

TOOLS REQUIRED

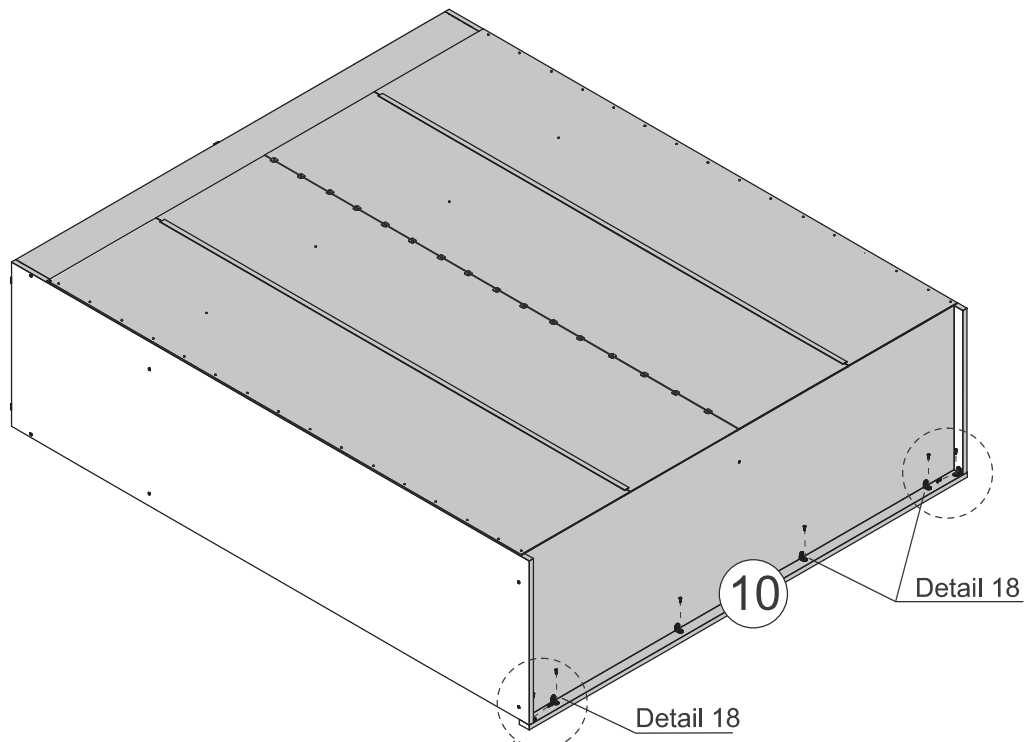
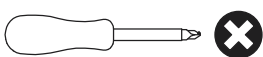

10

Detail 18

Detail 18

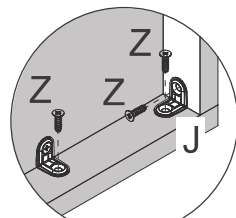

Detail 18

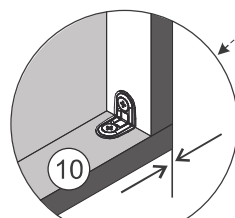

Align corners

STEP 18

PARTS REQUIRED

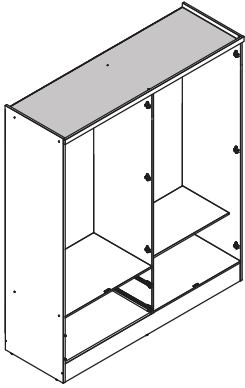

HARDWARE REQUIRED

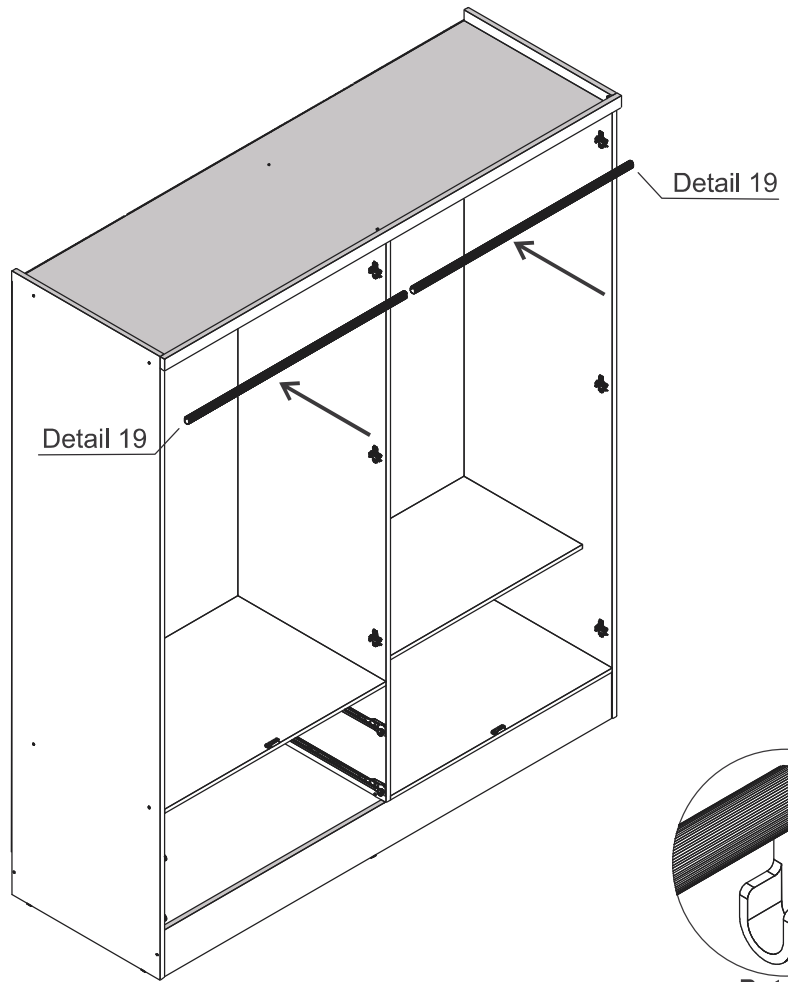

STEP 19

PARTS REQUIRED

15 - DRAWER SIDE x4

16 - DRAWER BACK PANEL x2

19 - DRAWER BOTTOM SUPPORT BAR x2

HARDWARE REQUIRED

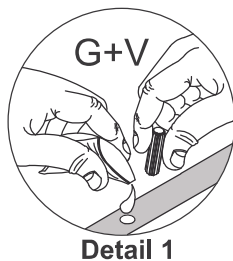
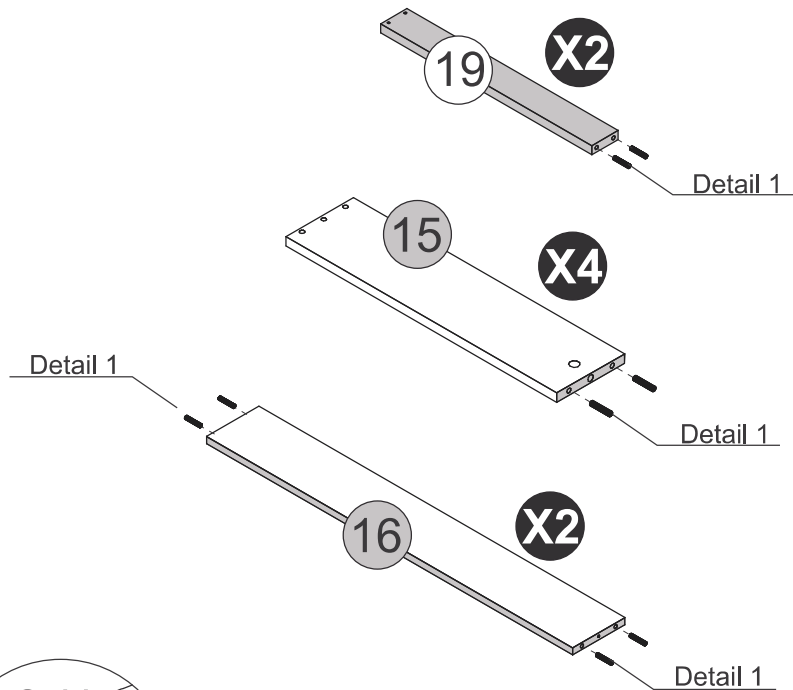
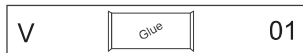
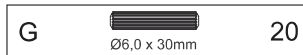

STEP 20

PARTS REQUIRED

17 - DRAWER FRONT x2

HARDWARE REQUIRED

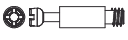
X  04

TOOLS REQUIRED

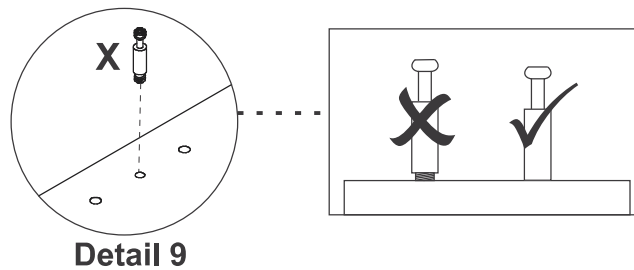
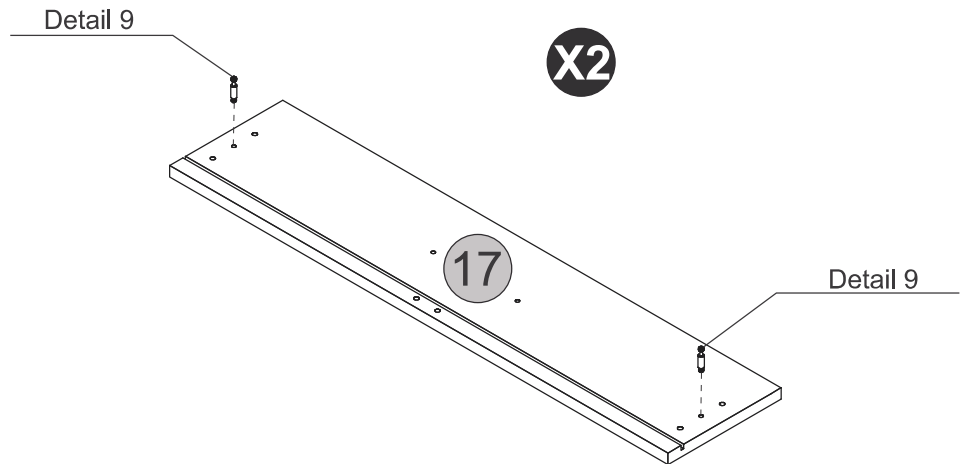
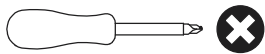

STEP 21

PARTS REQUIRED

15 - DRAWER SIDE x4

16 - DRAWER BACK PANEL x2

HARDWARE REQUIRED

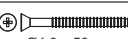
F  04
Ø4,0 x 50mm

TOOLS REQUIRED

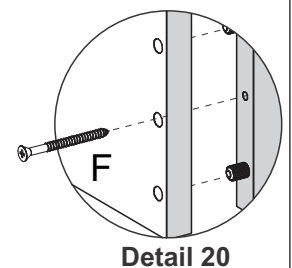
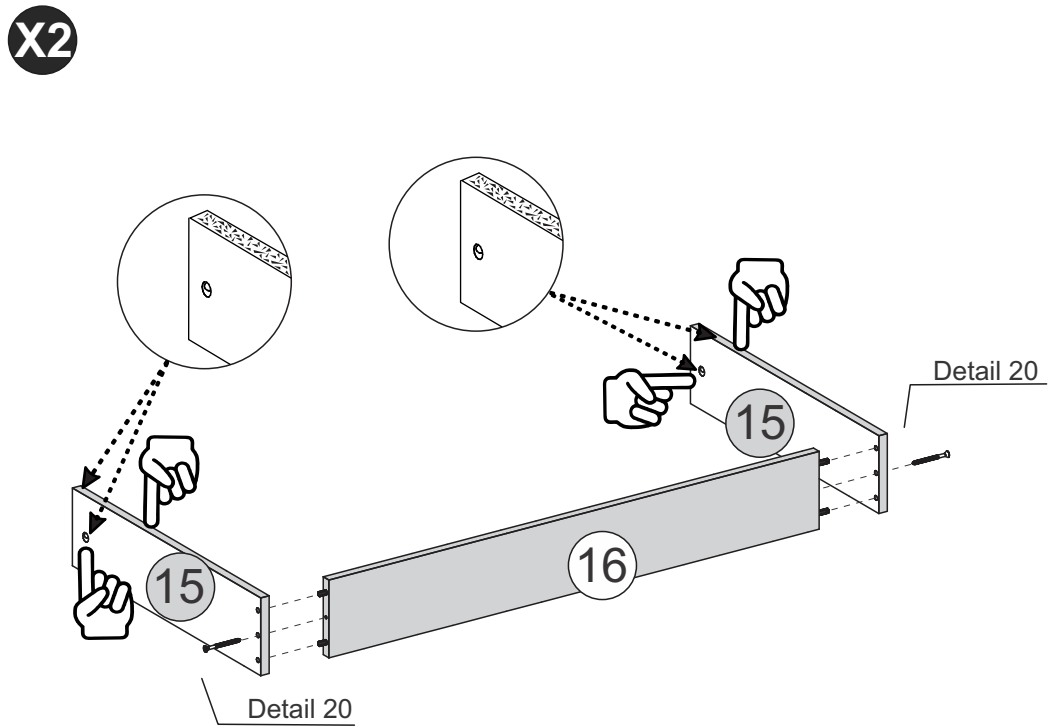
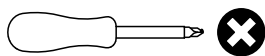

STEP 22

PARTS REQUIRED

17 - DRAWER FRONT x2

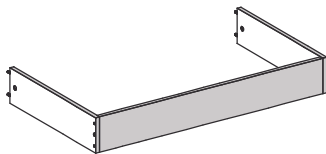

HARDWARE REQUIRED

B1  04

V  01

W  04

TOOLS REQUIRED

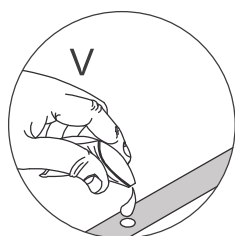
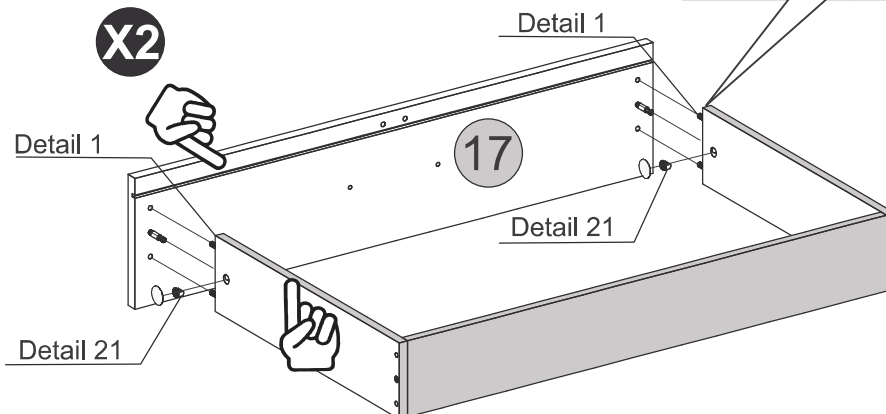
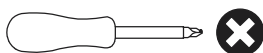

Detail 1

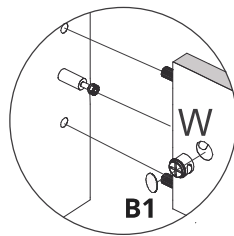

Detail 21

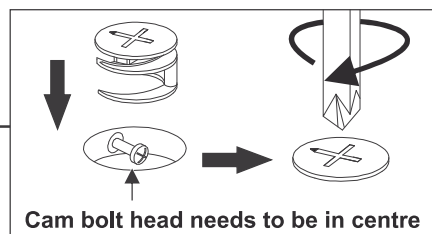

Cam bolt head needs to be in centre

STEP 23

PARTS REQUIRED

18 - DRAWER BOTTOM x2

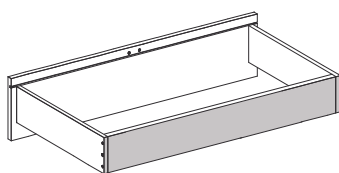

HARDWARE REQUIRED

H  08

TOOLS REQUIRED

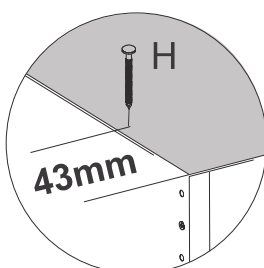
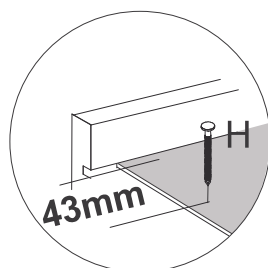
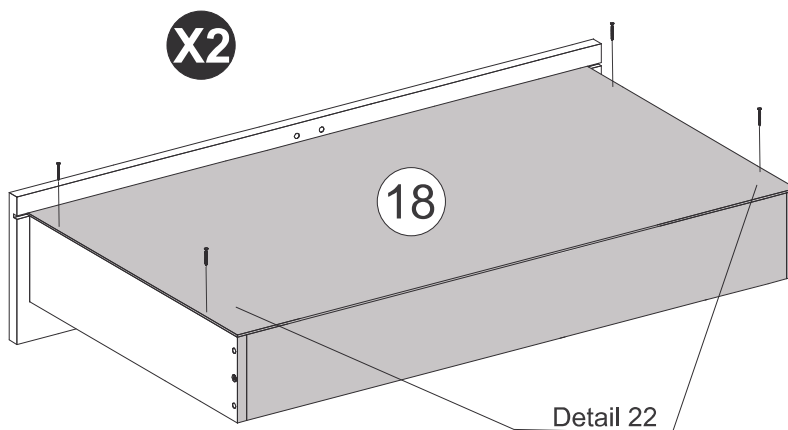
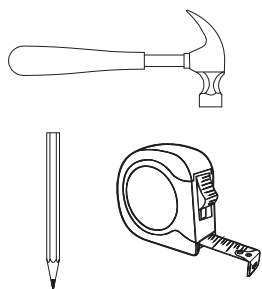

Detail 22

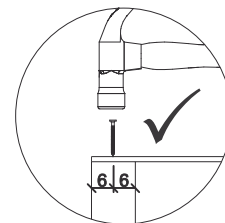
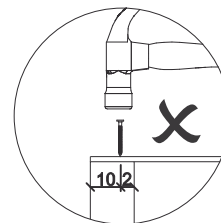
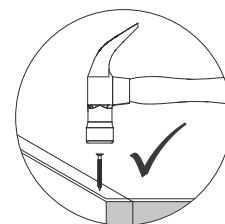
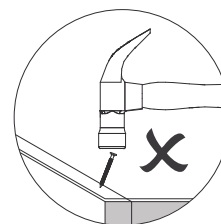

STEP 24

PARTS REQUIRED

19 - DRAWER BOTTOM SUPPORT BAR x2

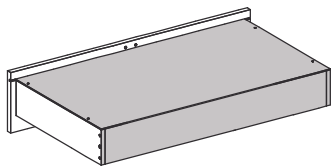

HARDWARE REQUIRED

H  12
10 x 10

V  01
GLUE

TOOLS REQUIRED

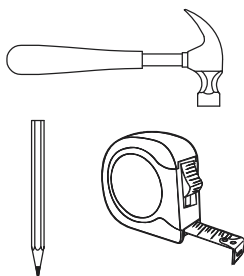

X2

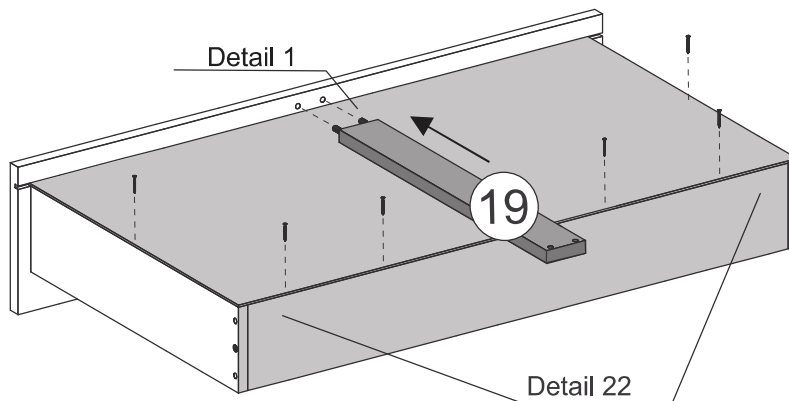

Detail 1

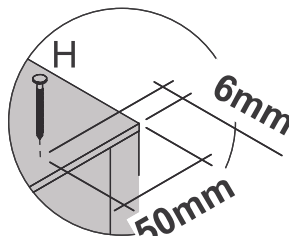

Detail 22

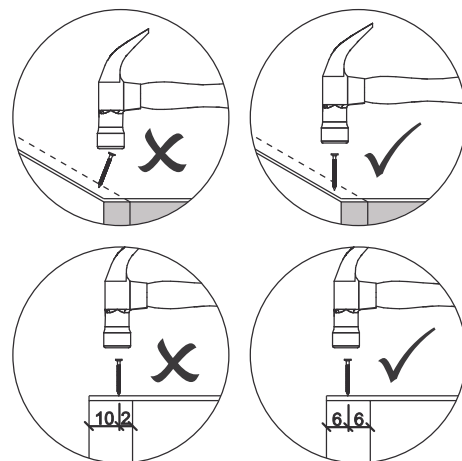

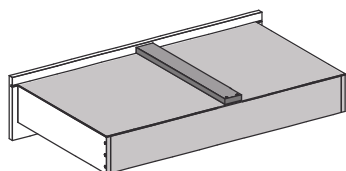

STEP 25

PARTS REQUIRED



HARDWARE REQUIRED

C  08
Ø4,0 x 14mm

E  04
Ø3,5 x 40mm

Q  02
LEFT

Q  02
RIGHT

TOOLS REQUIRED

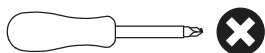

X2

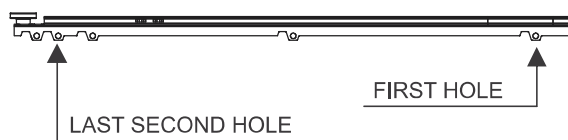
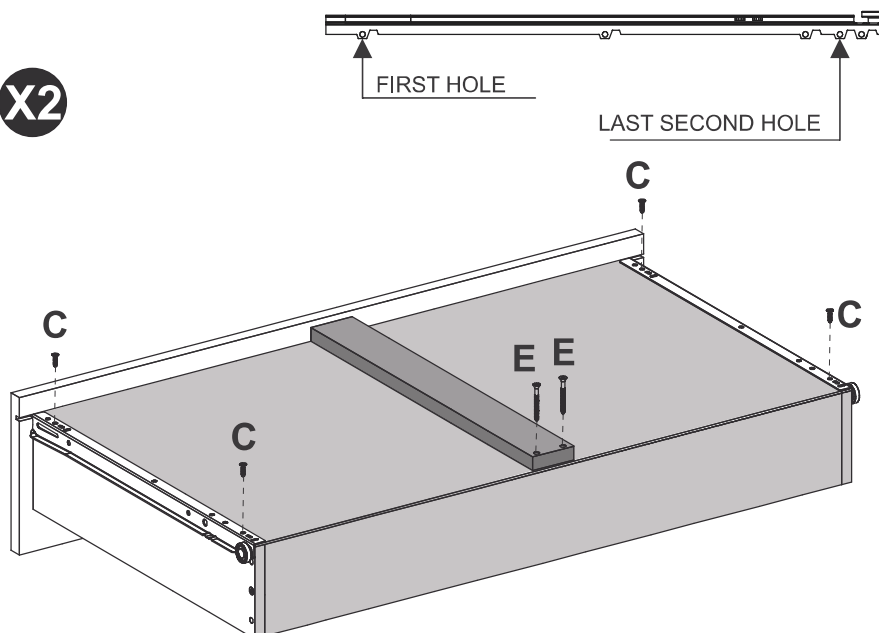

STEP 26

PARTS REQUIRED

11 - RIGHT LARGE DOOR x1

12 - LEFT LARGE DOOR x1

13 - RIGHT SMALL DOOR x1

14 - LEFT SMALL DOOR x1

HARDWARE REQUIRED

C  24
Ø4,0 x 14mm

O  12

TOOLS REQUIRED

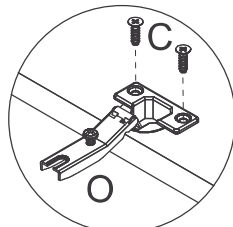
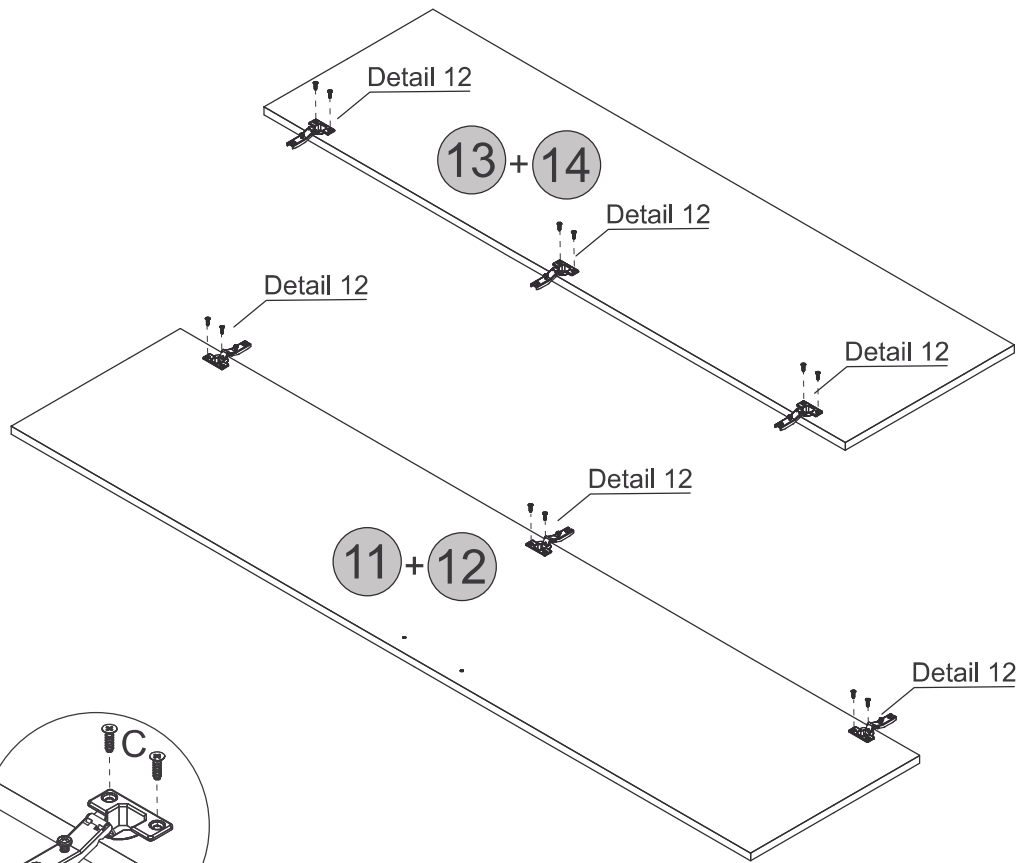
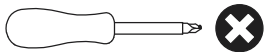

Detail 12

STEP 27

PARTS REQUIRED

11 - RIGHT LARGE DOOR x1

12 - LEFT LARGE DOOR x1

13 - RIGHT SMALL DOOR x1

14 - LEFT SMALL DOOR x1

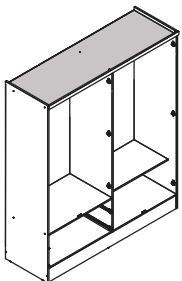

HARDWARE REQUIRED

U  26

TOOLS REQUIRED

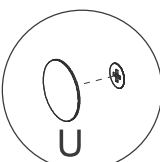
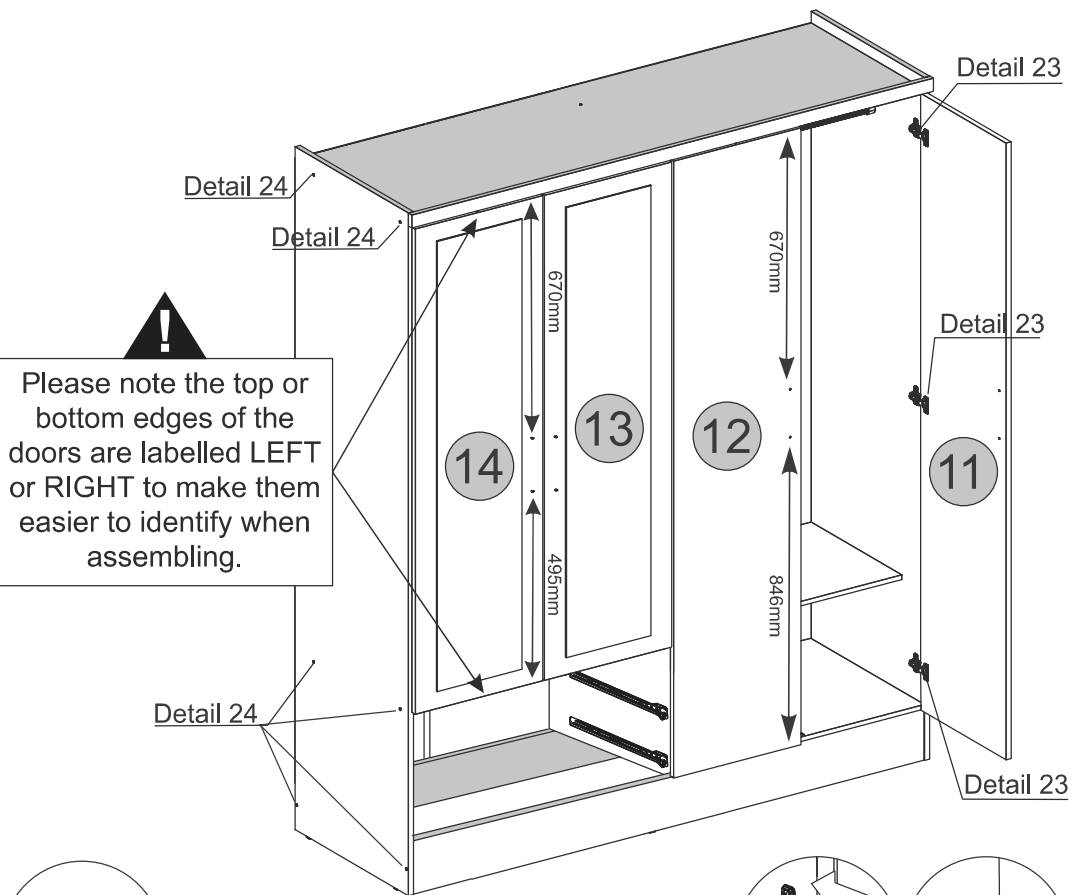
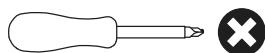

Detail 24

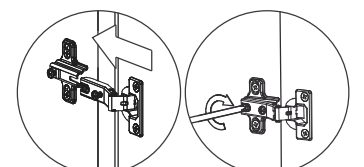

Detail 23

STEP 28

PARTS REQUIRED

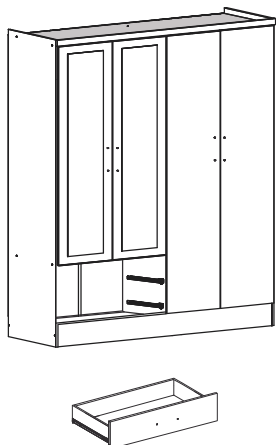

HARDWARE REQUIRED

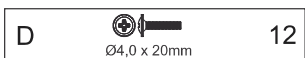

TOOLS REQUIRED

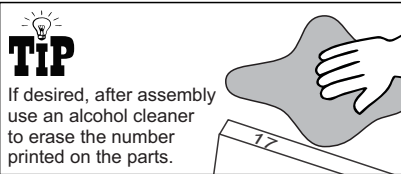

See the last page

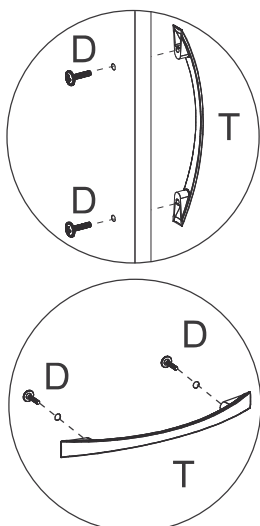

Detail 25

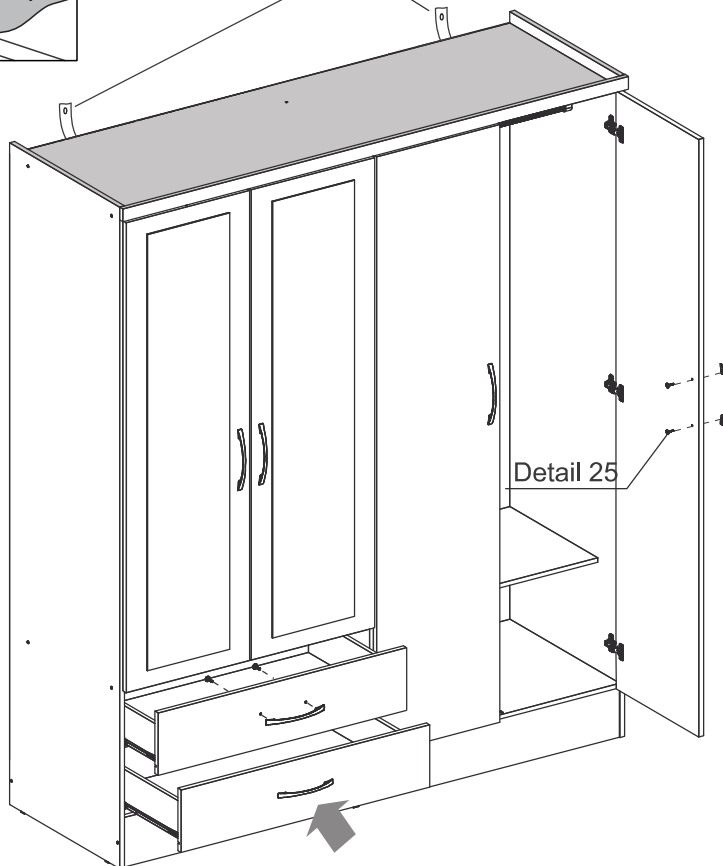

STEP 29

PARTS REQUIRED

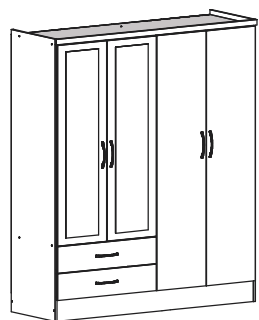

HARDWARE REQUIRED

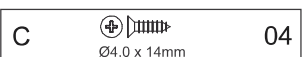

TOOLS REQUIRED

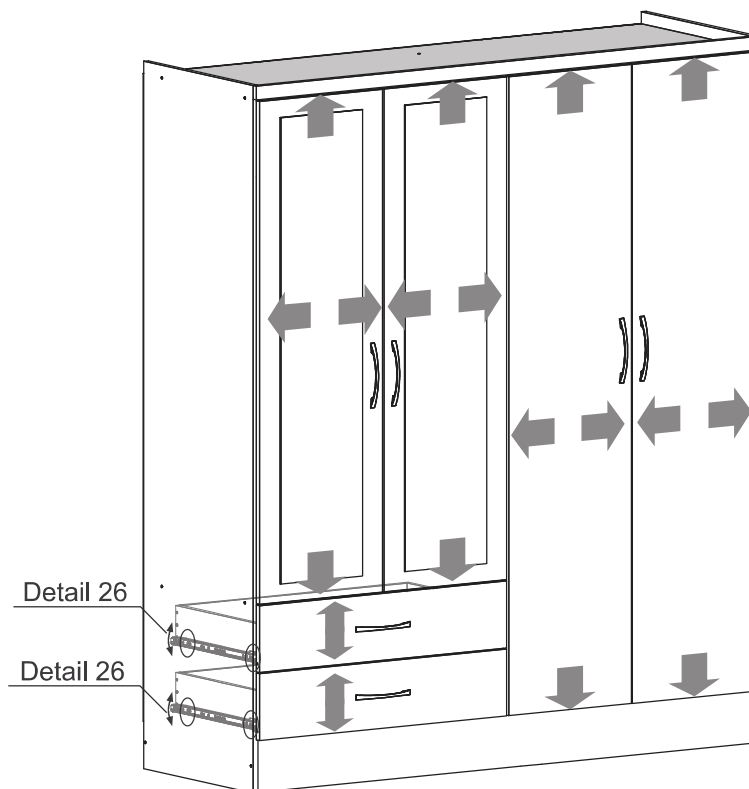

Drawer Adjustment

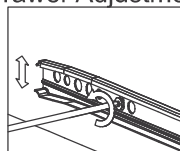

Drawer Lock

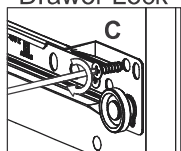

Detail 26

Height Adjustment

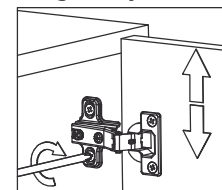

Internal Adjustment

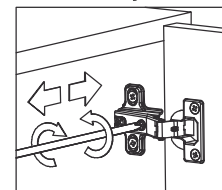

Depth Adjustment

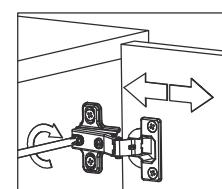
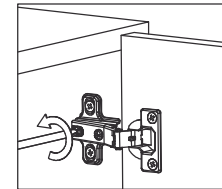

WARNING

Serious or fatal injuries can occur from furniture tipping over. To prevent the furniture from tipping over we recommend that it is permanently fixed to the wall.

Wall fixings are not supplied with this product as different wall materials require different types of fixing devices.
Please make sure you use fixings suitable for the walls in your home.

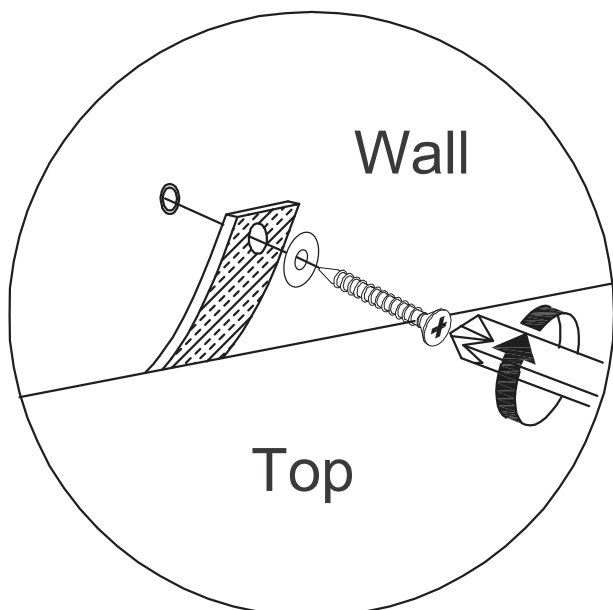
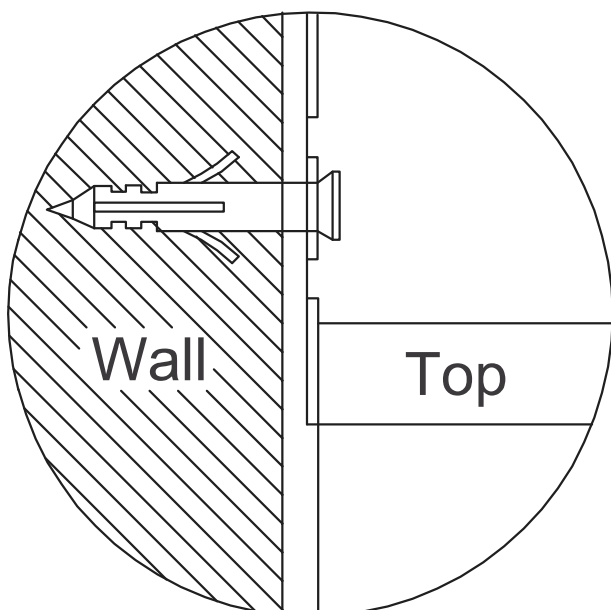
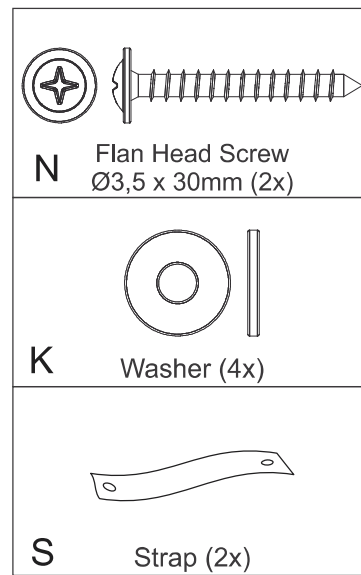
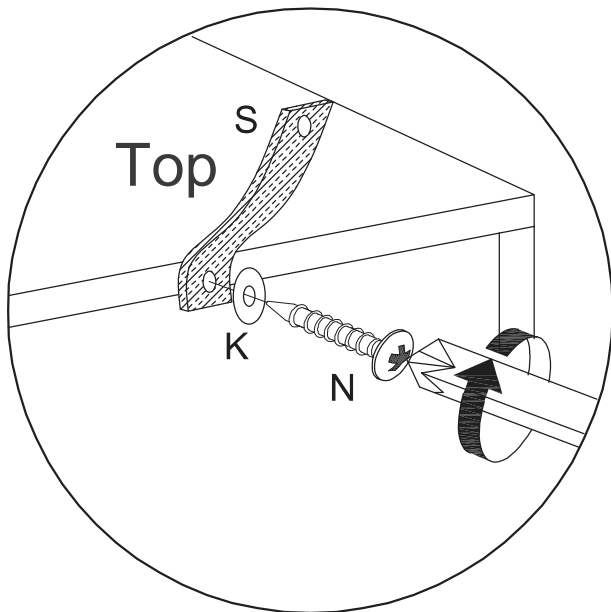

NEVADA 3+2 DRAWER CHEST ASSEMBLY INSTRUCTIONS

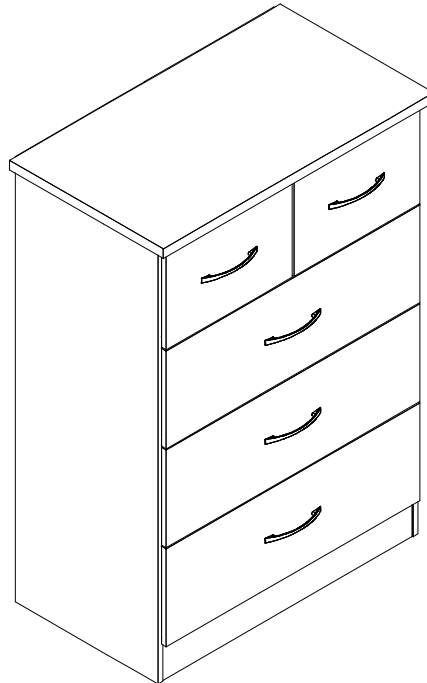

IMPORTANT FOR DOMESTIC USE ONLY PLEASE READ BEFORE YOU CONTINUE FURTHER CARE AND MAINTENANCE

After unpacking this product please keep the original packaging in case it needs to be returned for any reason.

- Please ensure all fittings and parts are present before commencing with assembly.
- Never drag or push products as this could cause damage to the joints making it inferior.
- We strongly recommend that you keep children away from your work area.
- We recommend that you lay a blanket or sheet on the floor to avoid damage to both your floor and the product.
- Assemble this product as close to its final position as possible.
- Do not place this product next to a radiator or in direct sunlight.
- Do not drag or push items across your high gloss furniture as this may cause the surface to scratch
- Wood is a natural product and may expand if subjected to damp and may shrink or crack if subjected to heat. Therefore it is recommended that room temperature is maintained, with no sudden temperature fluctuations.
- Make sure any spillage is wiped off immediately.
- Do not place hot or chilled items directly on to the surface, use a place mat or marking will occur.
- For general cleaning use a soft cotton or micro fibre cloth, and do not use detergents of any kind.
- From time to time it may be necessary to tighten fittings, regular inspections should be carried out.
- Do not place on a wet or damp floor as staining may occur to your floor.

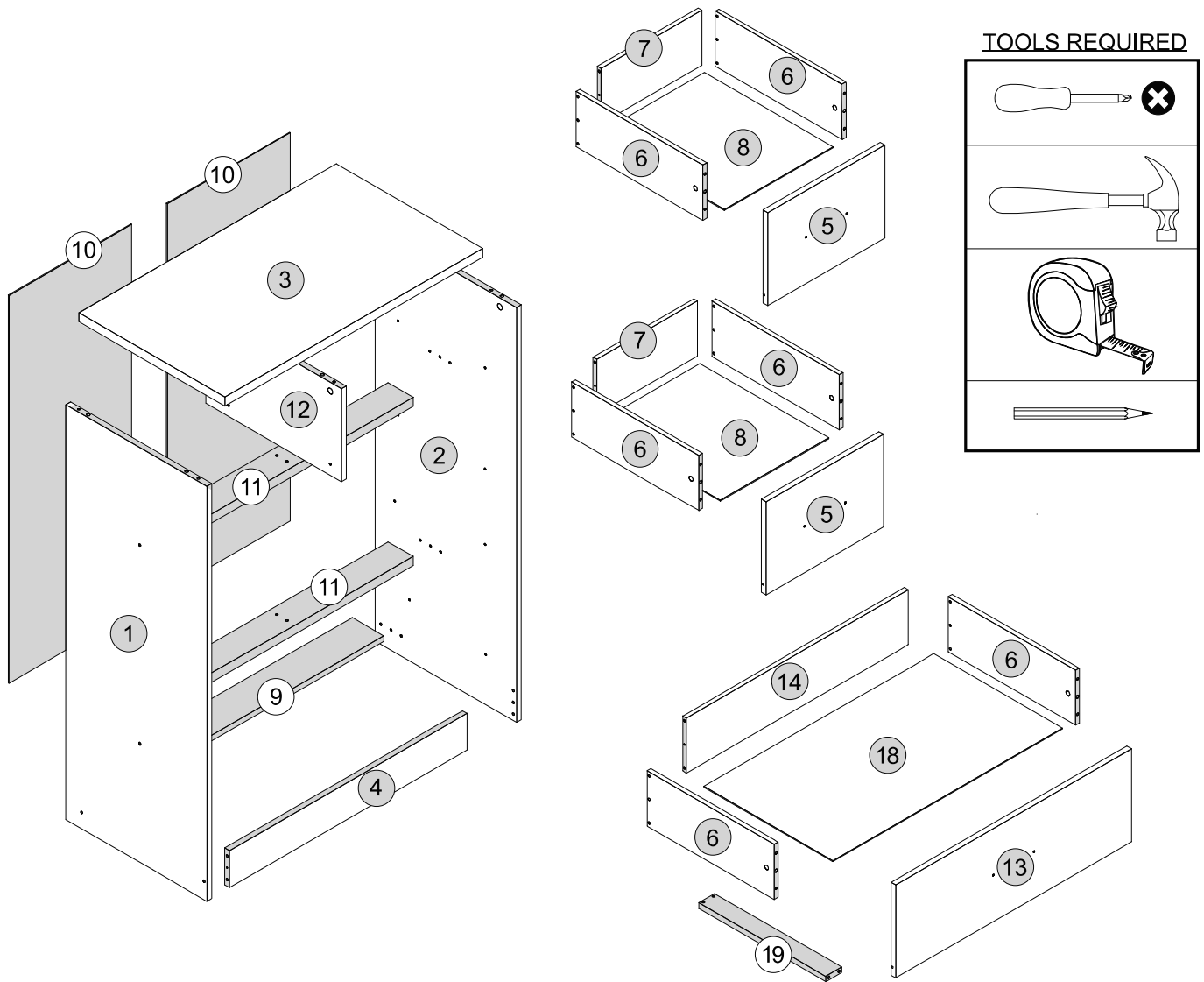









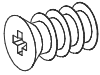
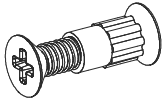
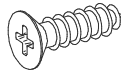
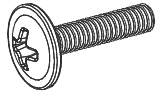
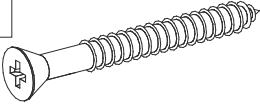
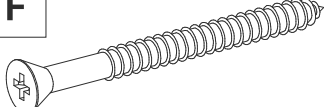
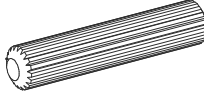

PARTS LIST

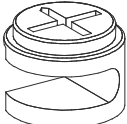
Please Note:
The below parts have all been stamped with the part number to help identify them during assembly.

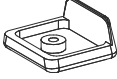
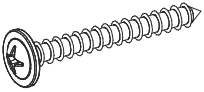
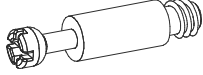
Part Number	Part Description	Quantity	Carton
01	Left Side Panel	1	1/2
02	Right Side Panel	1	1/2
03	Top Panel	1	2/2
04	Front Baseboard	1	1/2
05	Small Drawer Front	1	2/2
06	Drawer Side	10	1/2
07	Small Drawer Back Panel	2	1/2
08	Small Drawer Bottom	2	1/2
09	Back Baseboard	1	1/2
10	Back Panel	1	1/2
11	Crossbar	2	2/2
12	Division Panel	1	1/2
13	Large Drawer Front	3	2/2
14	Large Drawer Back Panel	3	1/2
18	Large Drawer Bottom	3	2/2
19	Drawer Bottom Support Bar	3	1/2

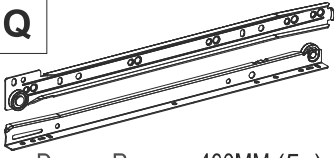
FITTINGS LIST

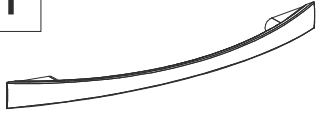
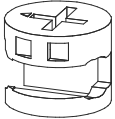
SEC/SH/09/21/HV1

<p>A</p>  <p>Flat Head Screw 2/+ Ø6,0 x 10mm (16x)</p>	<p>B</p>  <p>Double Flat Head Screw 1/+ Ø4,0 x 18mm (2x)</p>	<p>C</p>  <p>Flat Head Screw 2/+ Ø4,0 x 14mm (30x)</p>	<p>D</p>  <p>Flan Head Screw 2/+ Ø4,0 x 20mm (10x)</p>
<p>E</p>  <p>Flat Head Screw 1/+ Ø3,5 x 40mm (6x)</p>	<p>F</p>  <p>Flat Head Screw 2/+ Ø4,0 x 50mm (19x)</p>	<p>G</p>  <p>2/+ Dowel Ø6,0 x 30mm (69x)</p>	<p>H</p>  <p>2/+ Nail 10x10 Ringed-1,5x23mm (84x)</p>
<p>I</p>  <p>1/+ Back Panel Bracket 14x14mm (2x)</p>	<p>J</p>  <p>2/+ Cam Nut Ø12x8,8MM (10x)</p>	<p>K</p>  <p>1/+ Washer Ø16x7 (4x)</p>	<p>L</p>  <p>1/+ Plastic Foot L 19x17x8mm Ø2 (6x)</p>
<p>M</p>  <p>Flan Head Screw 1/+ Ø3,5 x 30mm (2x)</p>	<p>N</p>  <p>2/+ Cam Bolt (16x)</p>	<p>O</p>  <p>2/+ Hole Plugs 19MM (9x)</p>	<p>P</p>  <p>Glue 10Gr (3x)</p>
<p>Q</p>  <p>Drawer Runners 400MM (5x)</p>	<p>R</p>  <p>Back Panel Strip H 799x19x3,8mm (1x)</p>	<p>S</p>  <p>Strap 200x20x1MM (2x)</p>	<p>T</p>  <p>Handle (5x)</p>
<p>U</p>  <p>1/+ Cam Nut Ø14,9x11MM (6x)</p>	<p>V</p>  <p>+2 Hole Plugs Líneo 19mm (9x)</p>		

TIPS FOR FITTINGS CAM-LOCKS

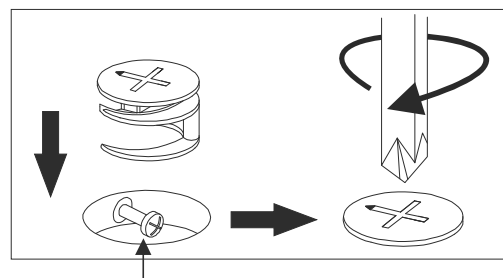
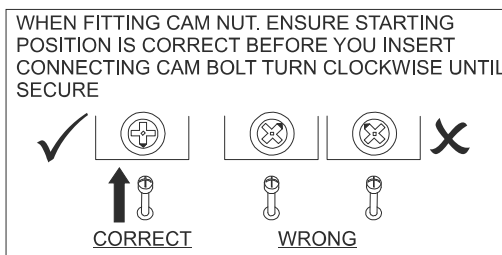

Cam bolt head needs to be in centre

CAMBOLT

Tighten until shoulder is flush with panel. Do not overtighten or undertighten (see example below)

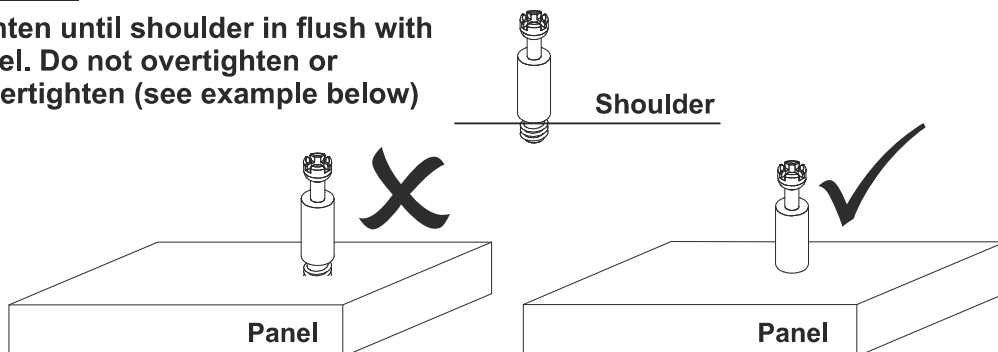

STEP 1

PARTS REQUIRED

1 - LEFT SIDE PANEL x1

HARDWARE REQUIRED

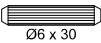
G  02
Ø6 x 30

H  02
10 x 10

L  02

P  01
GLUE

TOOLS REQUIRED

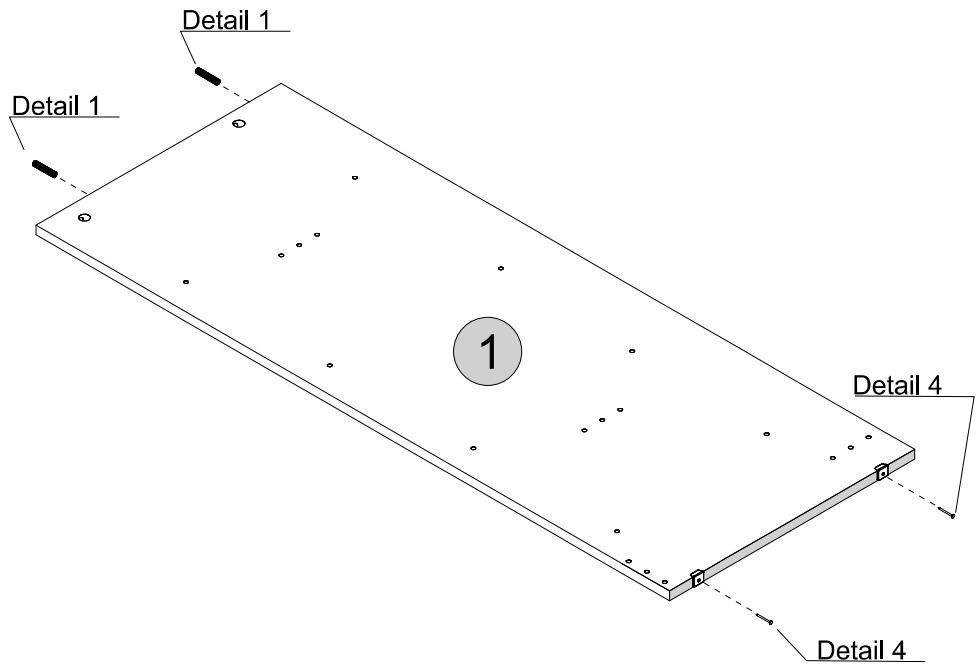
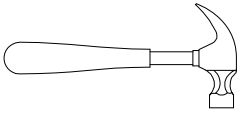

Detail 1

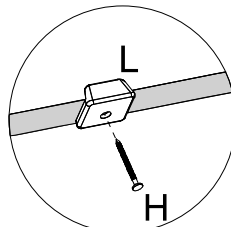

Detail 4

STEP 2

PARTS REQUIRED

2 - RIGHT SIDE PANEL x1

HARDWARE REQUIRED

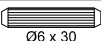
G  02
Ø6 x 30

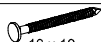
H  02
10 x 10

L  02

P  01
GLUE

TOOLS REQUIRED

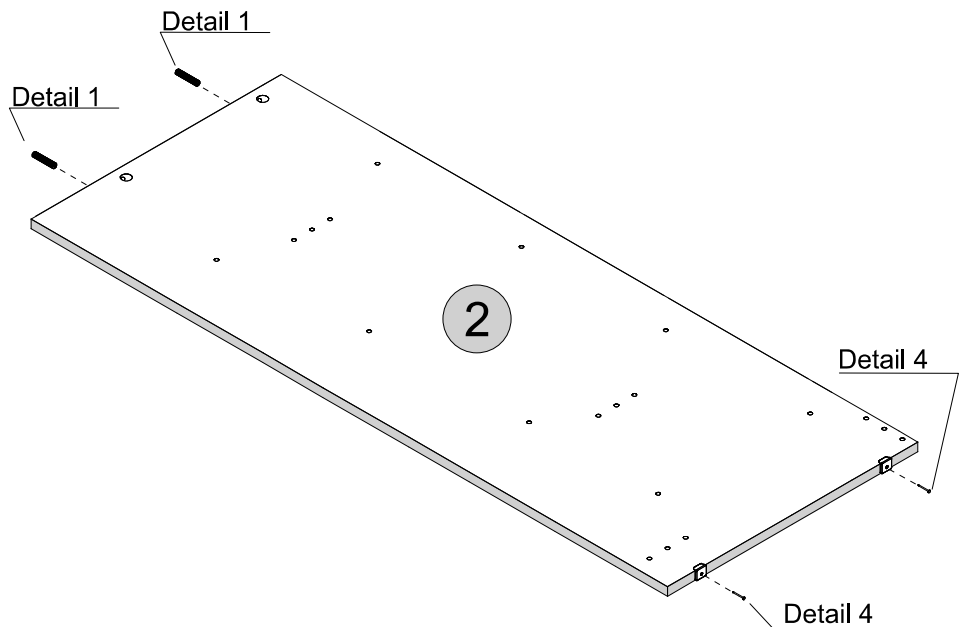
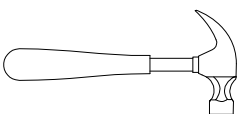

Detail 1

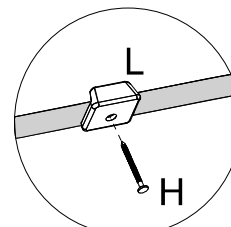

Detail 4

STEP 3

PARTS REQUIRED

1 - LEFT SIDE PANEL x1

HARDWARE REQUIRED

A  08
Ø6 x 10

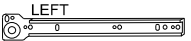
Q  04
LEFT

TOOLS REQUIRED

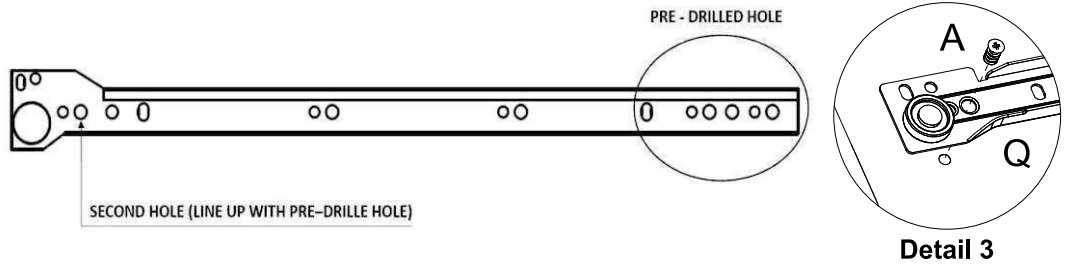
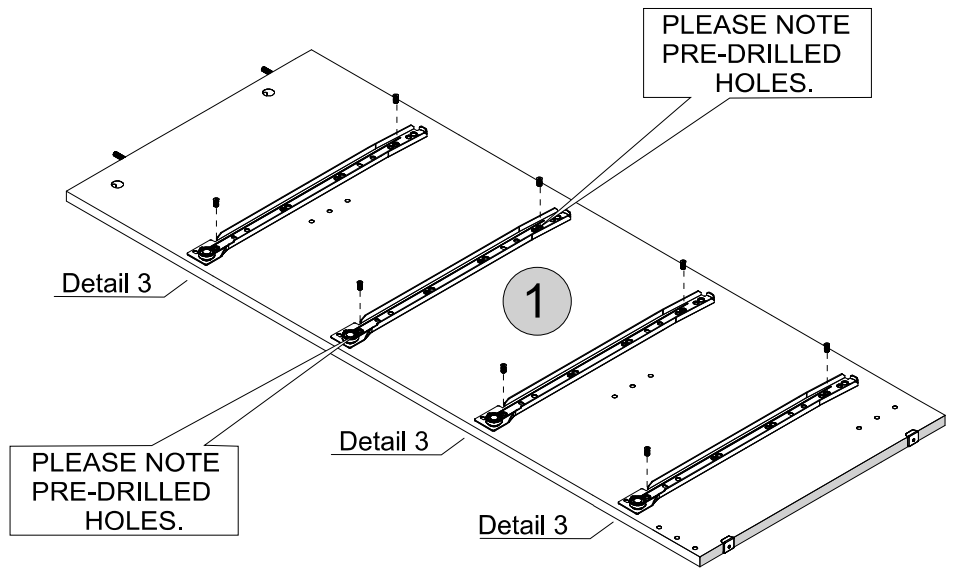
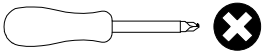



STEP 4

PARTS REQUIRED

2 - RIGHT SIDE PANEL x1

HARDWARE REQUIRED

A  08
Ø6 x 10

Q  04
RIGHT

TOOLS REQUIRED

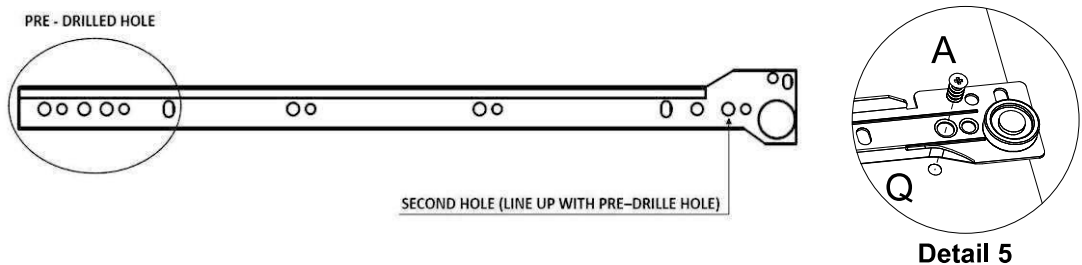
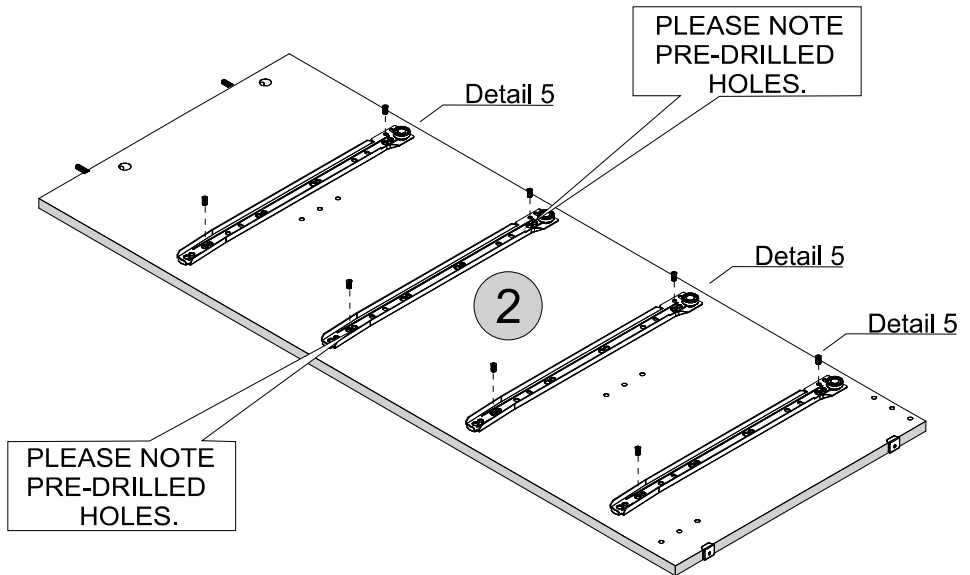
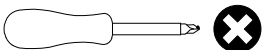

STEP 5

PARTS REQUIRED

4 - FRONT BASEBOARD x1

9 - BACK BASEBOARD x1

11 - CROSSBAR x2

HARDWARE REQUIRED

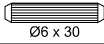
G  16
Ø6 x 30

H  02
10 x 10

L  02

P  01
GLUE

TOOLS REQUIRED

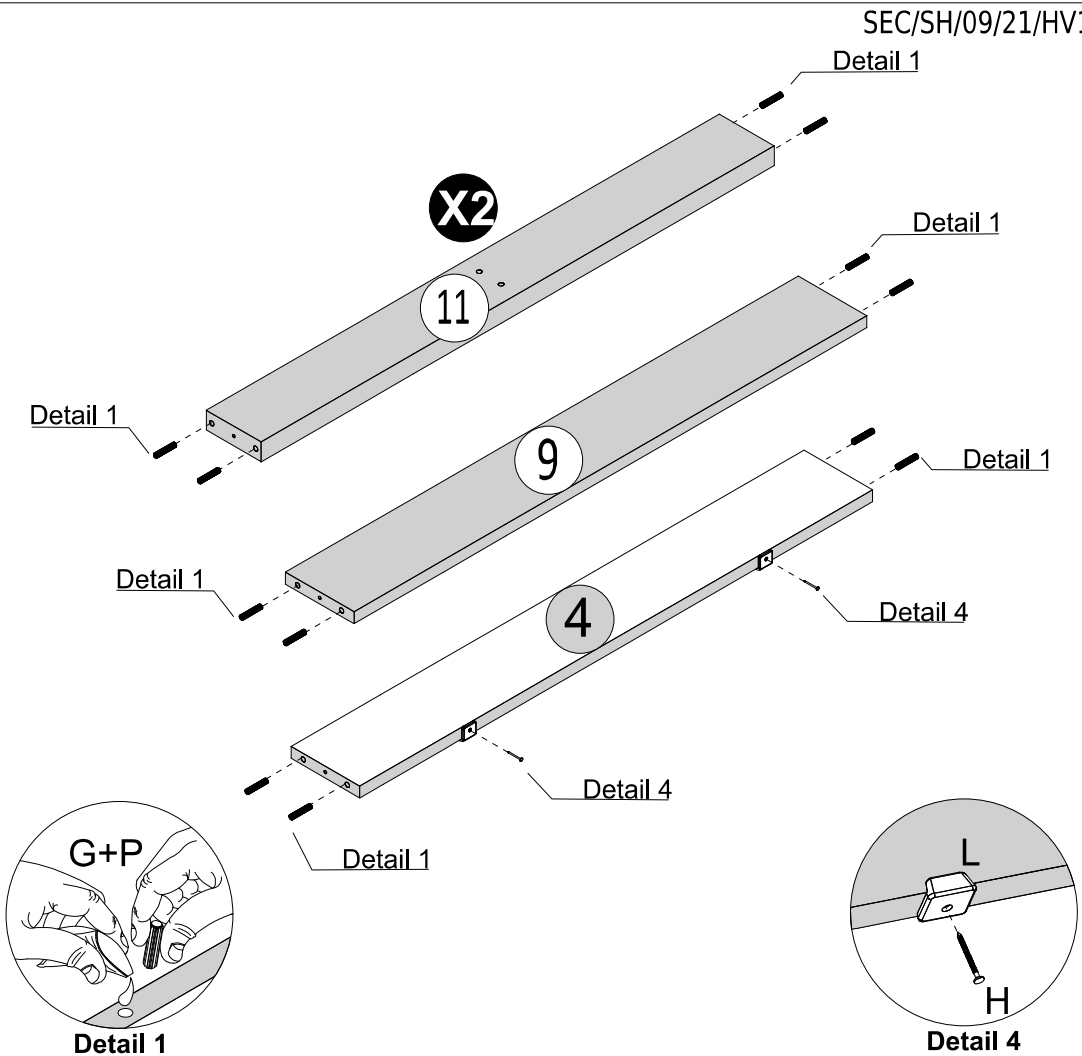
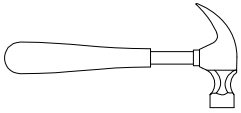

STEP 6

PARTS REQUIRED

12 - DIVISION PANEL x1

HARDWARE REQUIRED

B  02
Ø4.0 x 18mm

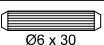
G  03
Ø6 x 30

P  01
GLUE

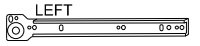
Q  01
LEFT

Q  01
RIGHT

TOOLS REQUIRED

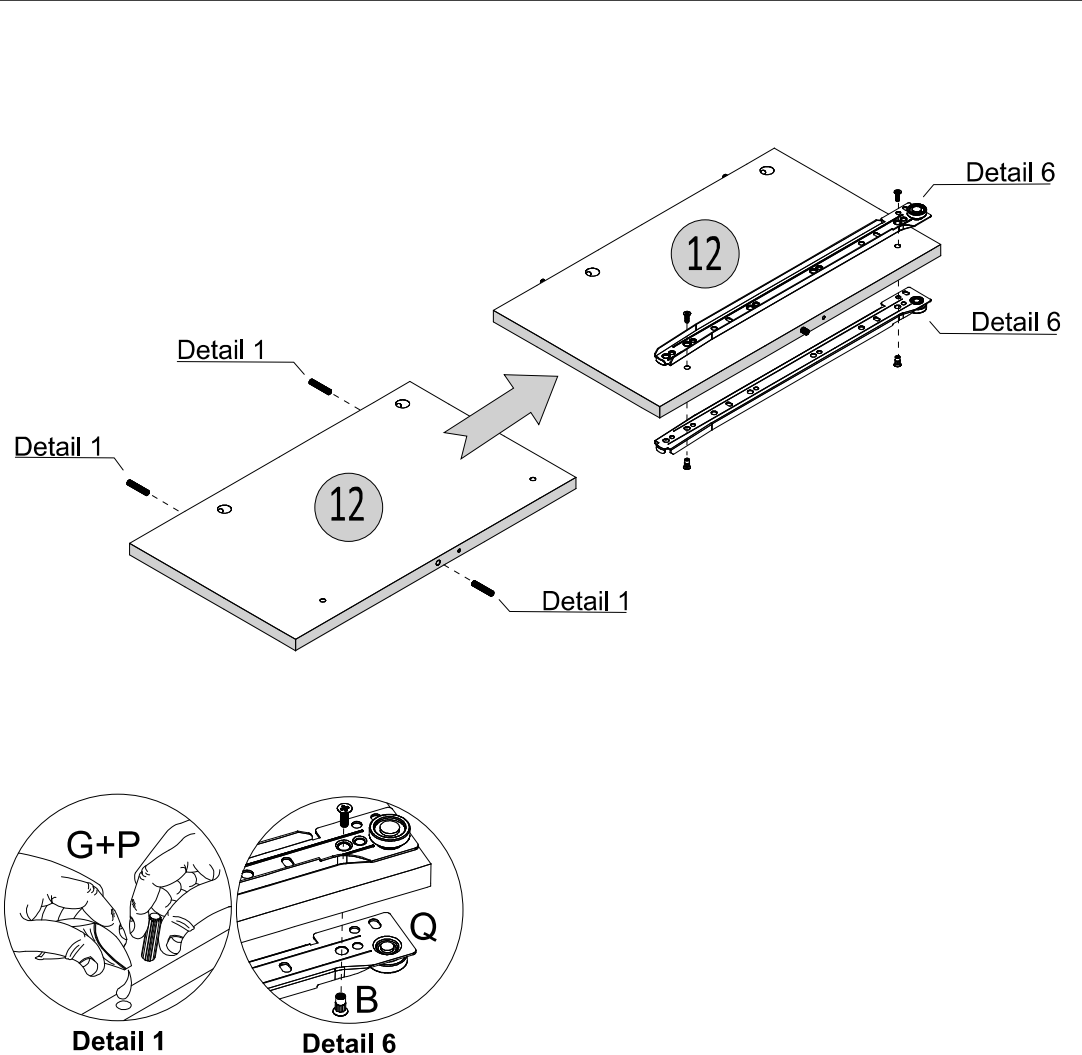
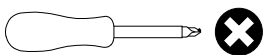



STEP 7

PARTS REQUIRED

- 2 - RIGHT SIDE PANEL x1
- 4 - FRONT BASEBOARD x1
- 9 - BACK BASEBOARD x1
- 11 - CROSSBAR x2

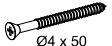
HARDWARE REQUIRED

- F  04
Ø4 x 50
- P  01
GLUE

TOOLS REQUIRED

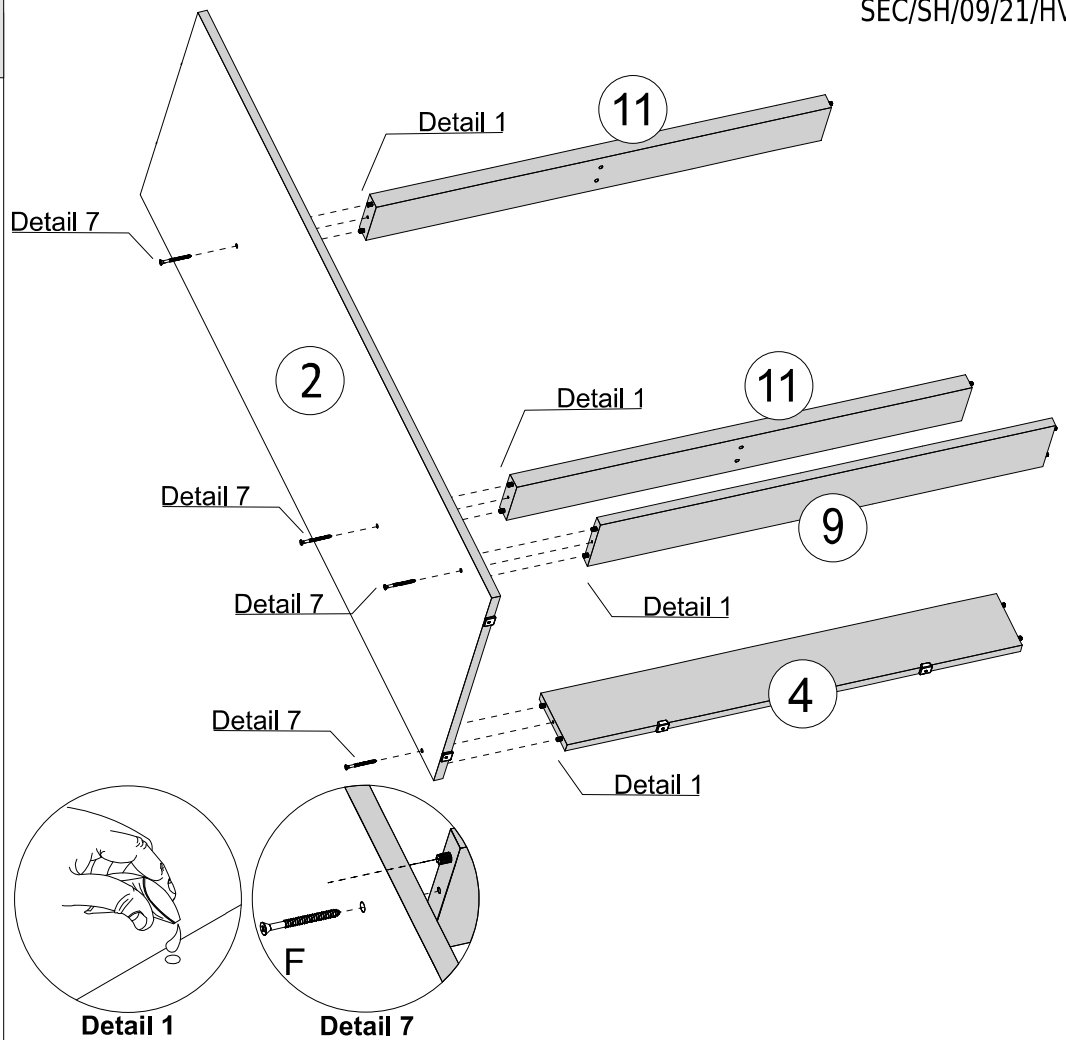
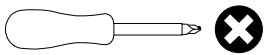



STEP 8

PARTS REQUIRED

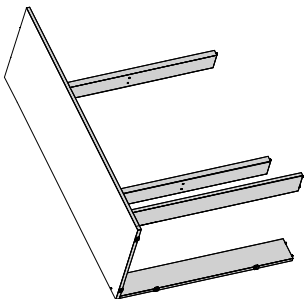
- 1 - LEFT SIDE PANEL x1

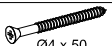

HARDWARE REQUIRED

- F  04
Ø4 x 50
- P  01
GLUE

TOOLS REQUIRED

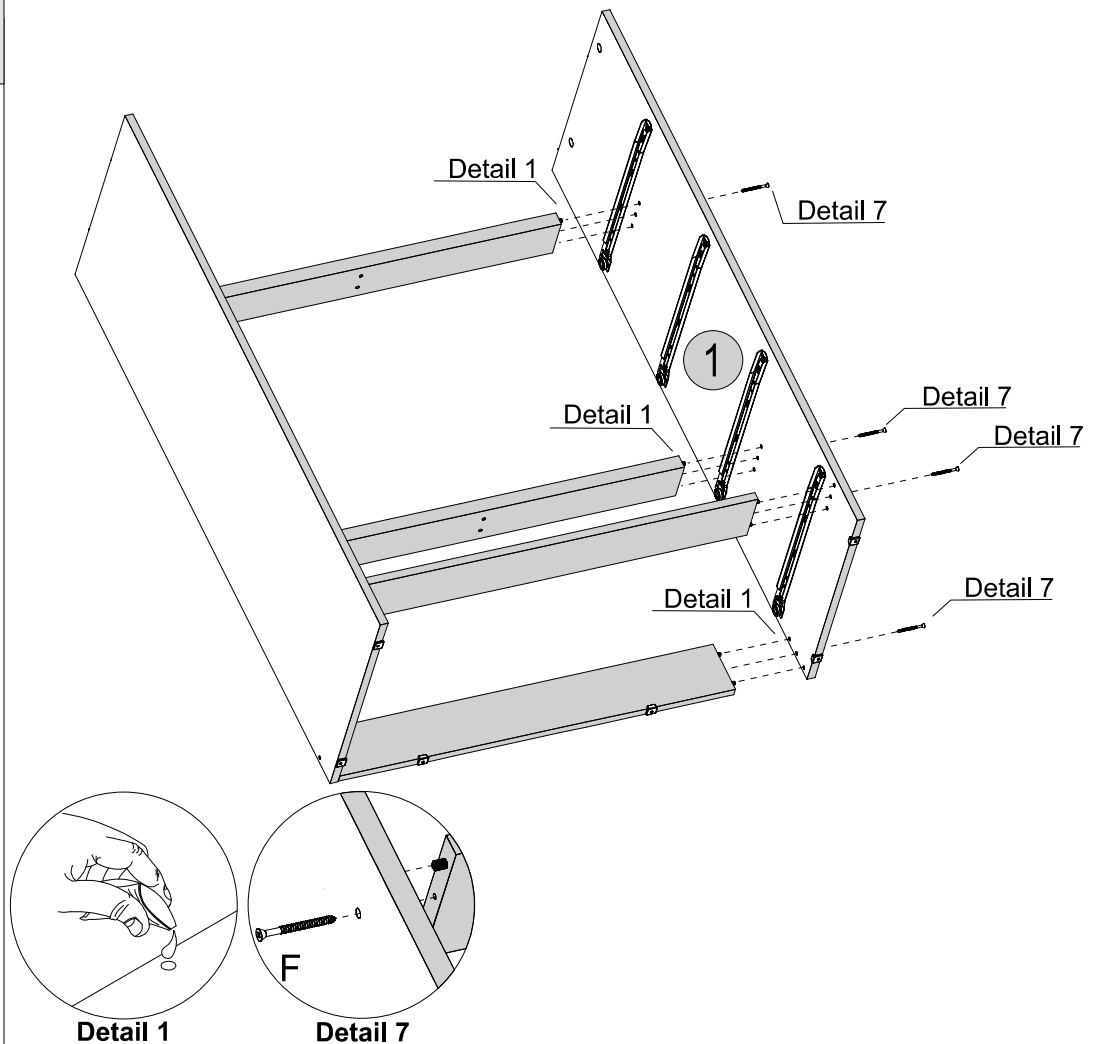
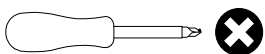

STEP 9

PARTS REQUIRED

3 - TOP PANEL x1

HARDWARE REQUIRED

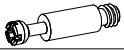
N  06

TOOLS REQUIRED

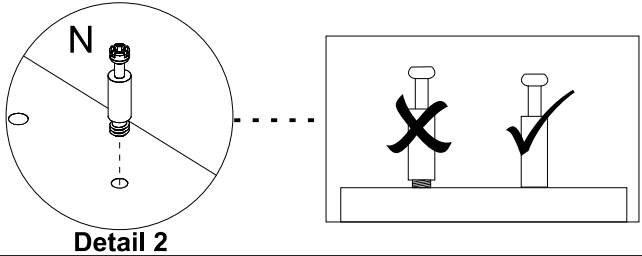
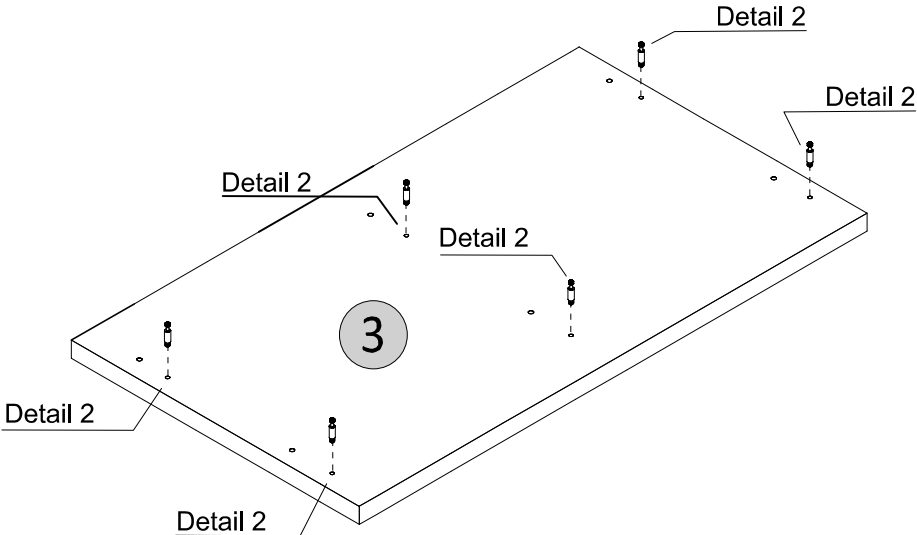
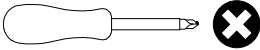

STEP 10

PARTS REQUIRED

3 - TOP PANEL x1

12 - DIVISION PANEL x1

HARDWARE REQUIRED

U  02

TOOLS REQUIRED

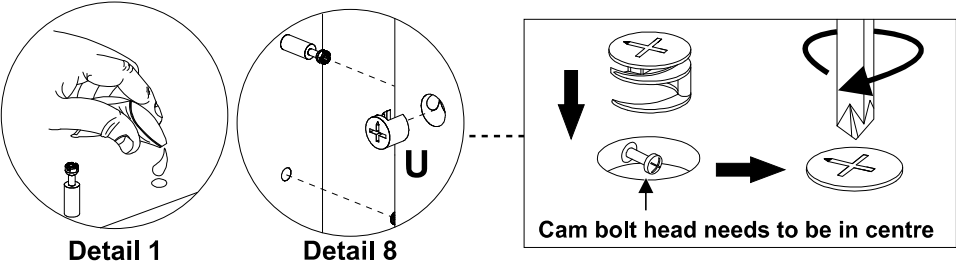
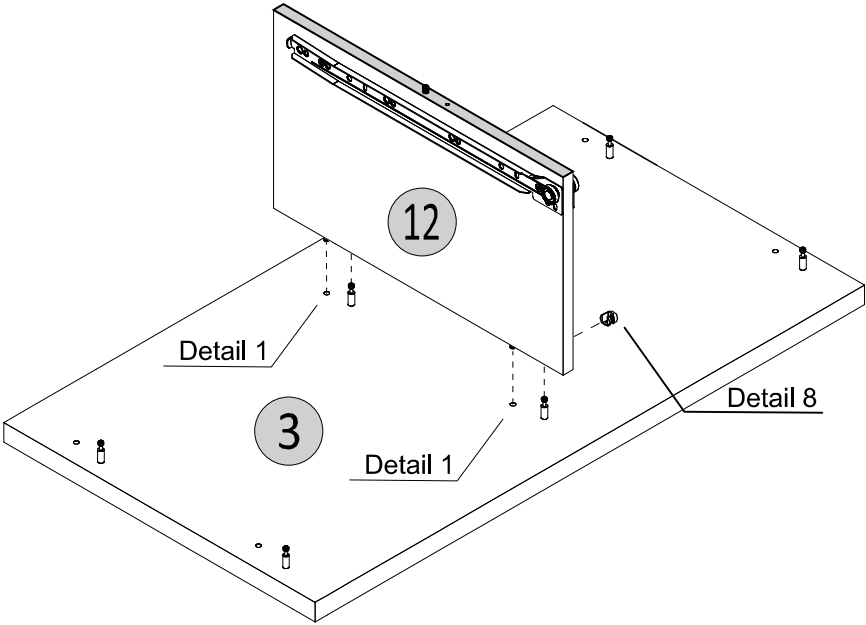
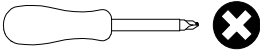

STEP 11

PARTS REQUIRED

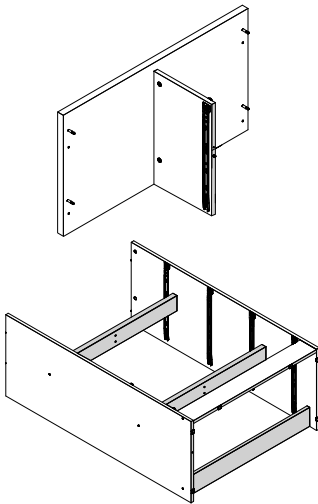

HARDWARE REQUIRED



TOOLS REQUIRED

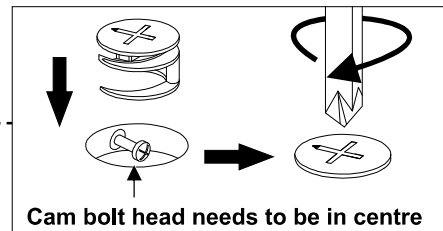
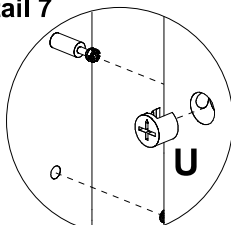
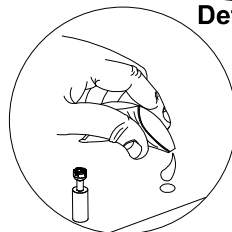
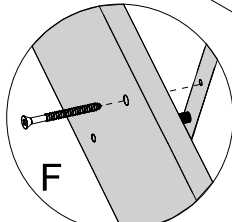
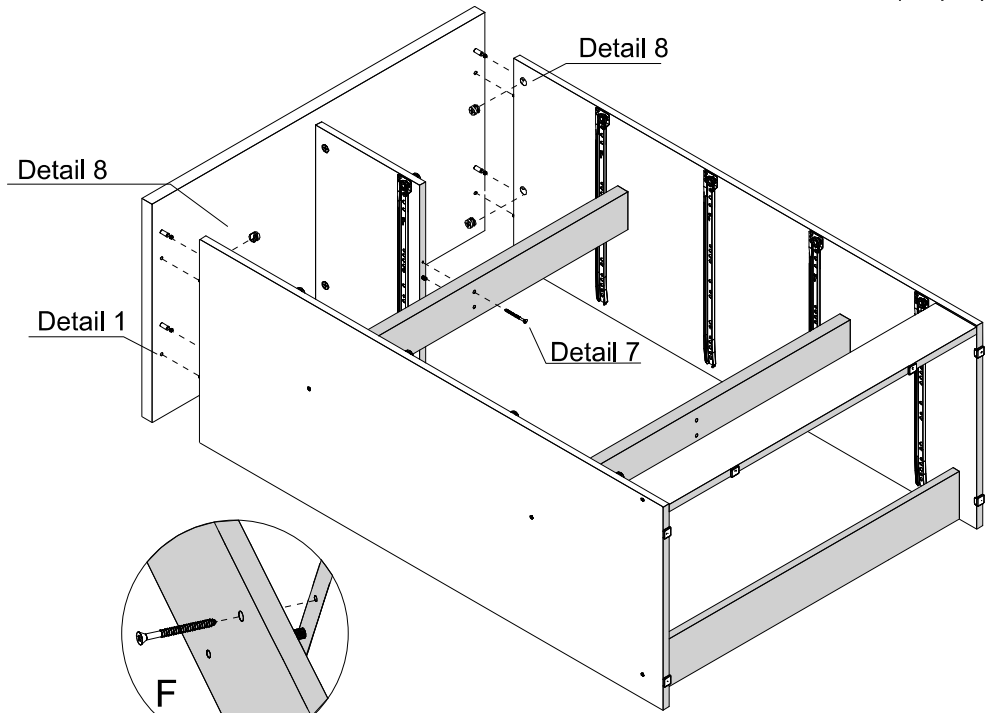
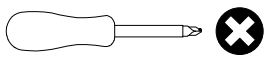

STEP 12

PARTS REQUIRED

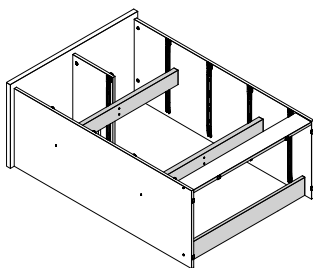

HARDWARE REQUIRED

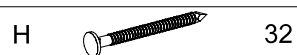

TOOLS REQUIRED

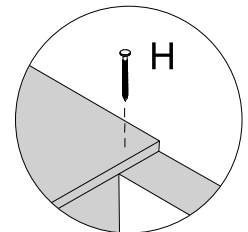
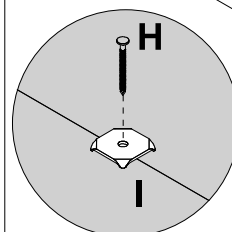
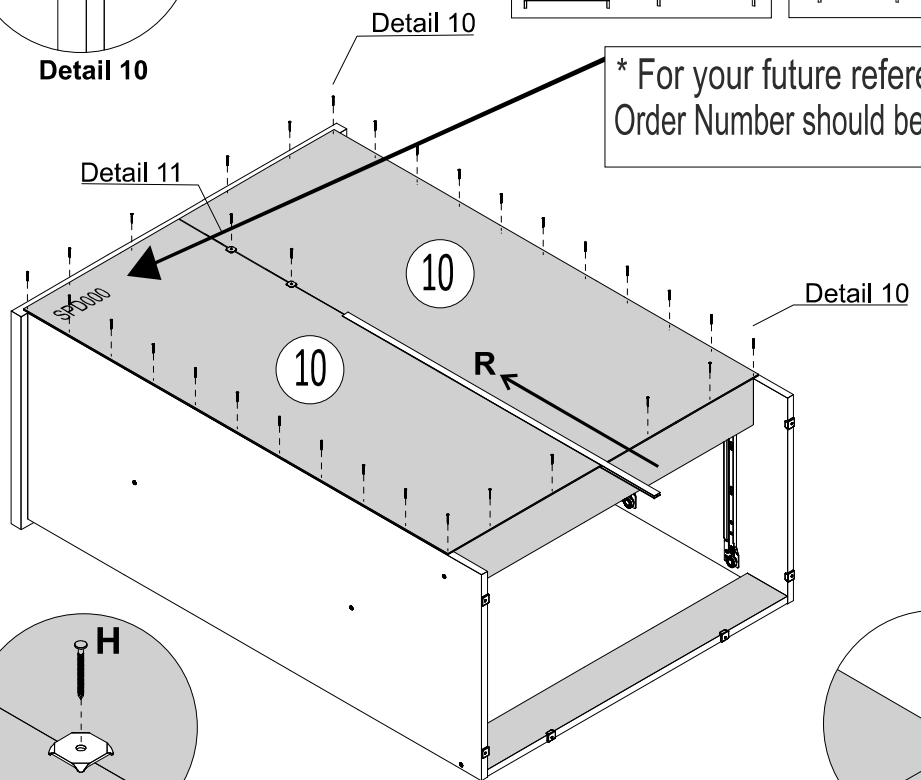
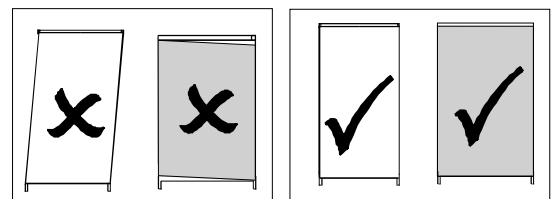
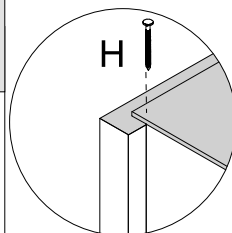
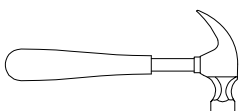



STEP 13

PARTS REQUIRED

- 6 - DRAWER SIDE x10
- 7 - SMALL DRAWER BACK PANEL x2
- 14 -LARGE DRAWER BACK PANEL x3
- 19 -DRAWER BOTTOM SUPPORT BAR x3

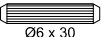
HARDWARE REQUIRED

- G  46
- P  01

TOOLS REQUIRED



Detail 1

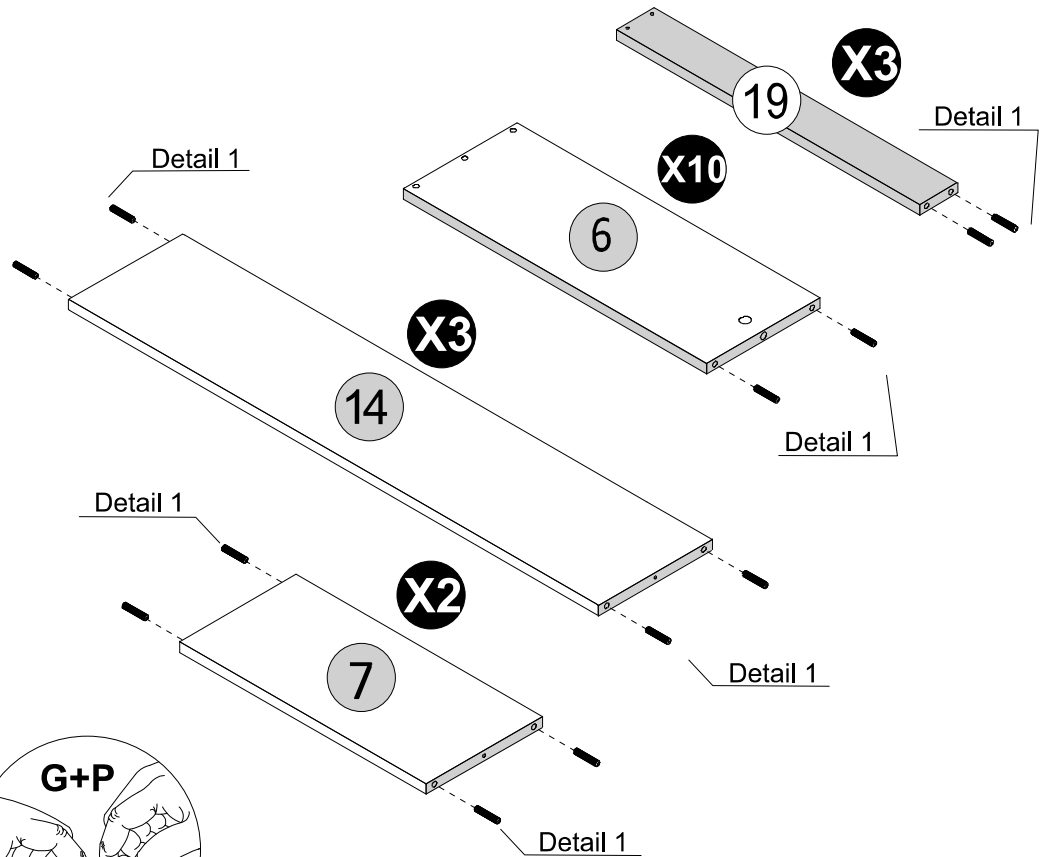

STEP 14

PARTS REQUIRED

- 13 -LARGE DRAWER FRONT x3
- 5 - SMALL DRAWER FRONT x2

HARDWARE REQUIRED

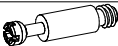
- N  10

TOOLS REQUIRED

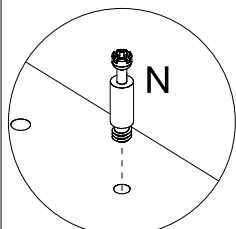
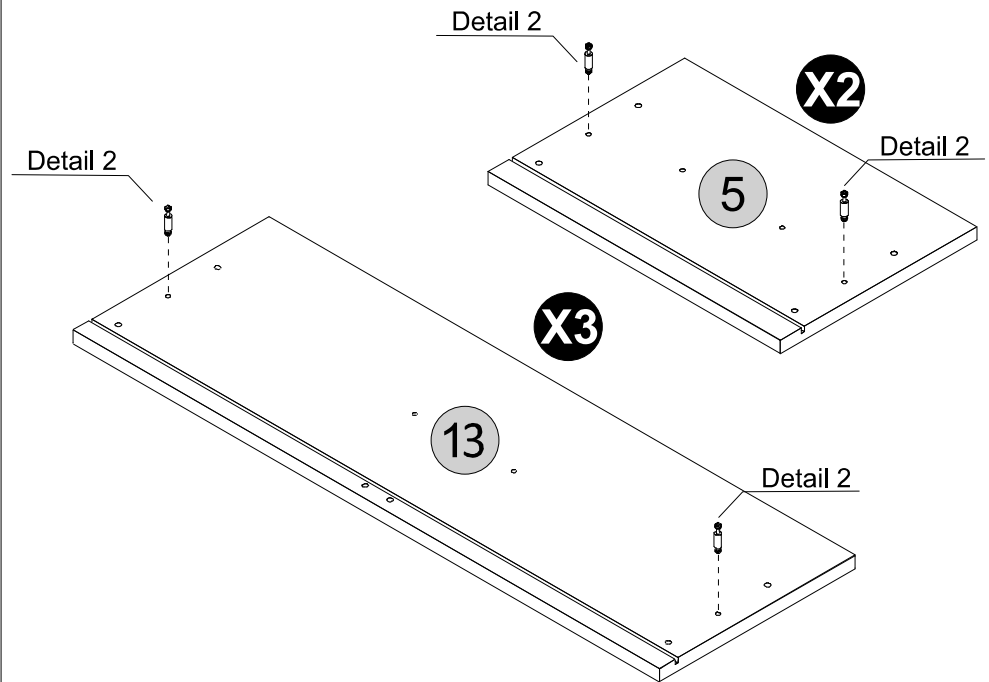
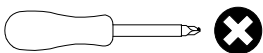

Detail 2

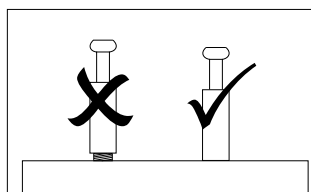

STEP 15

PARTS REQUIRED

6 - DRAWER SIDE x6

14 - LARGE DRAWER BACK PANEL x3

HARDWARE REQUIRED

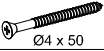
F  06
Ø4 x 50

TOOLS REQUIRED

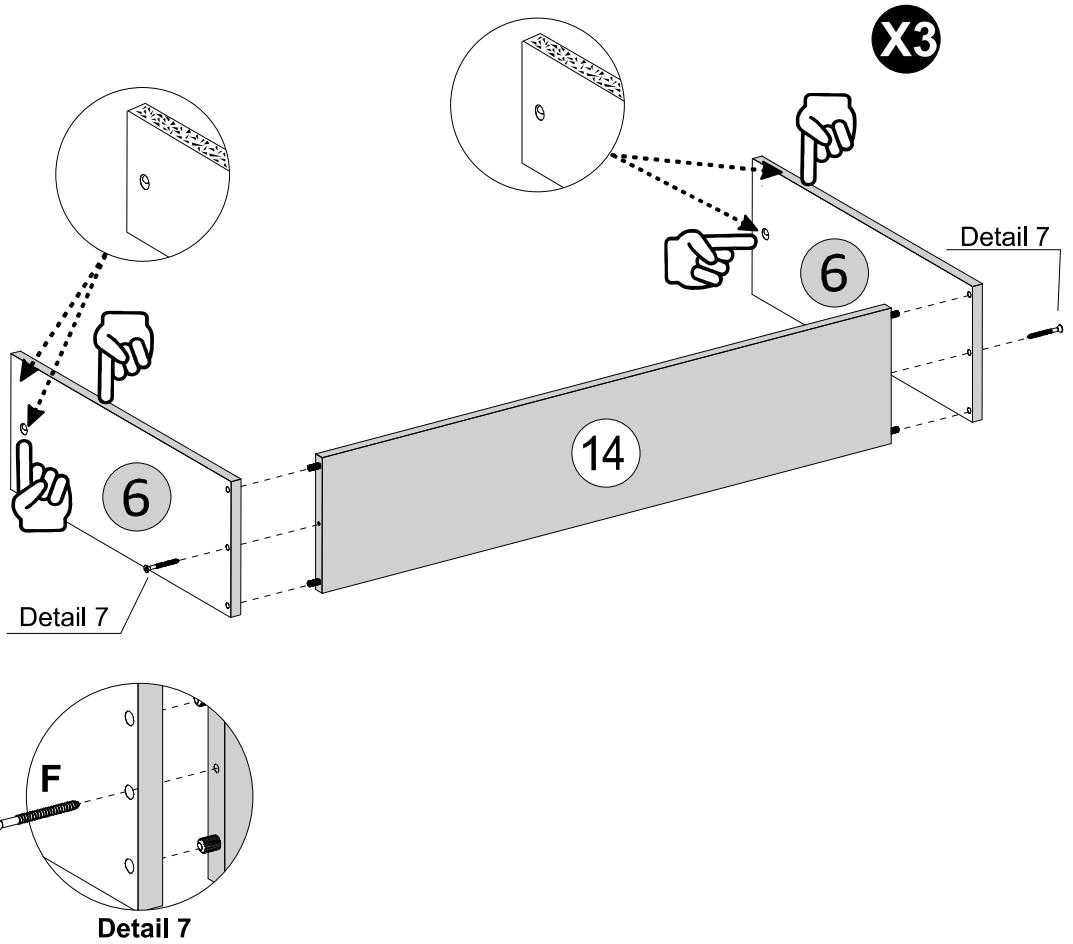
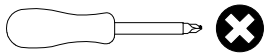

STEP 16

PARTS REQUIRED

13 - LARGE DRAWER FRONT x3

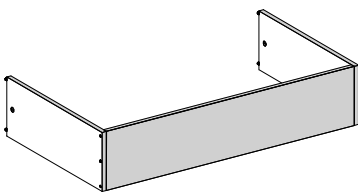

HARDWARE REQUIRED

J  06

P  01
GLUE

TOOLS REQUIRED

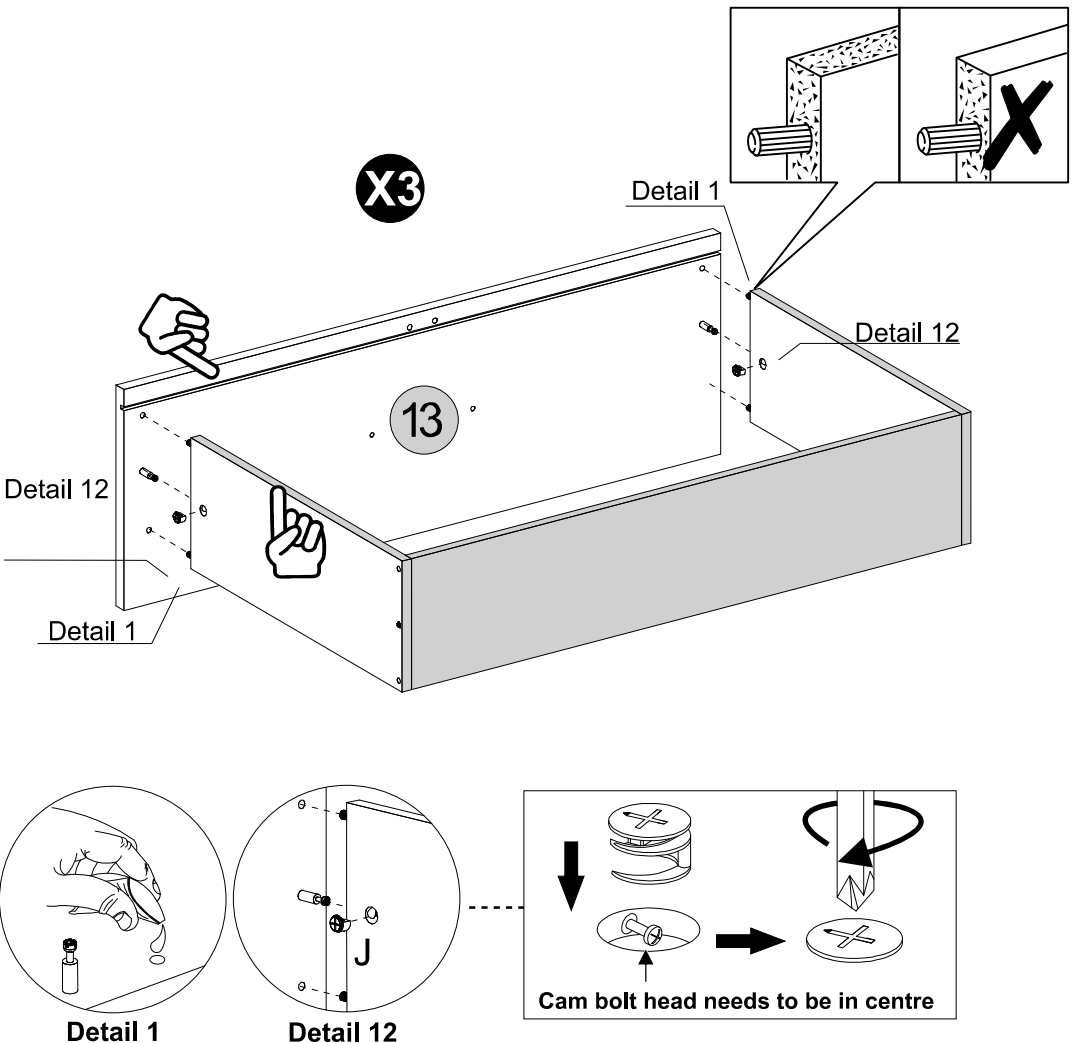
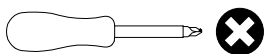

STEP 17

PARTS REQUIRED

18 -LARGE DRAWER BOTTOM x3

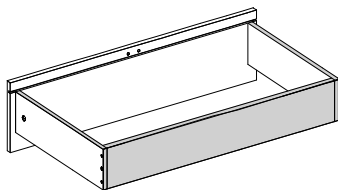

HARDWARE REQUIRED

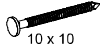
H  12

TOOLS REQUIRED

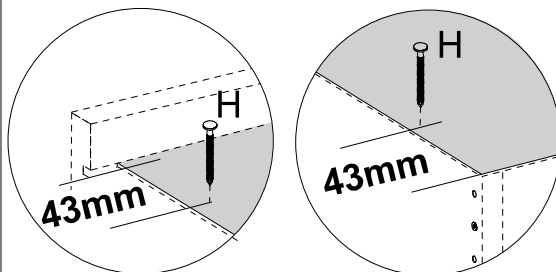
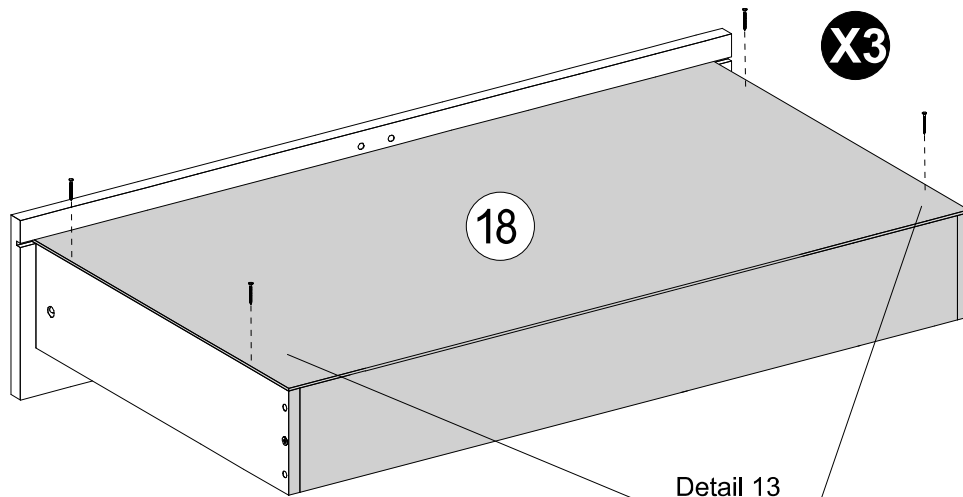
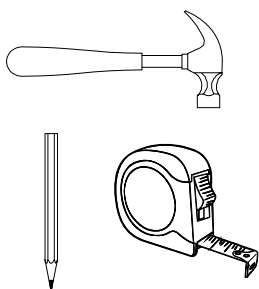

Detail 13

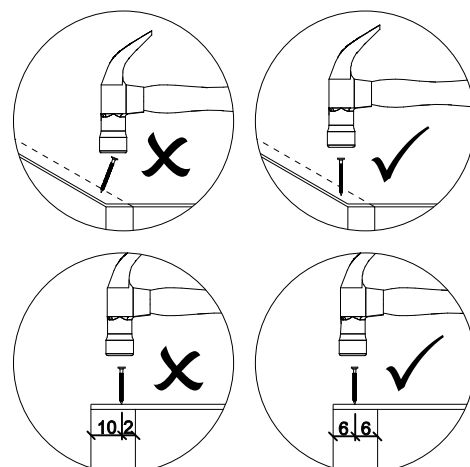

STEP 18

PARTS REQUIRED

19 -DRAWER BOTTOM SUPPORT BAR x3

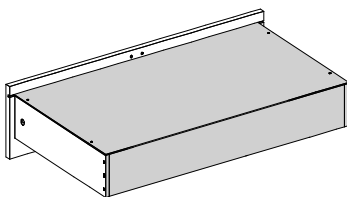

HARDWARE REQUIRED

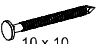
H  18

P  01

TOOLS REQUIRED

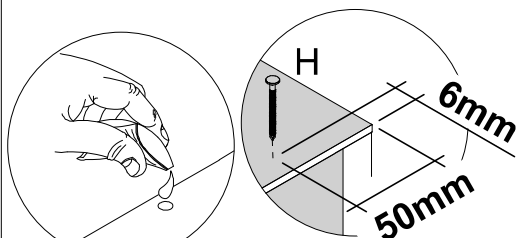
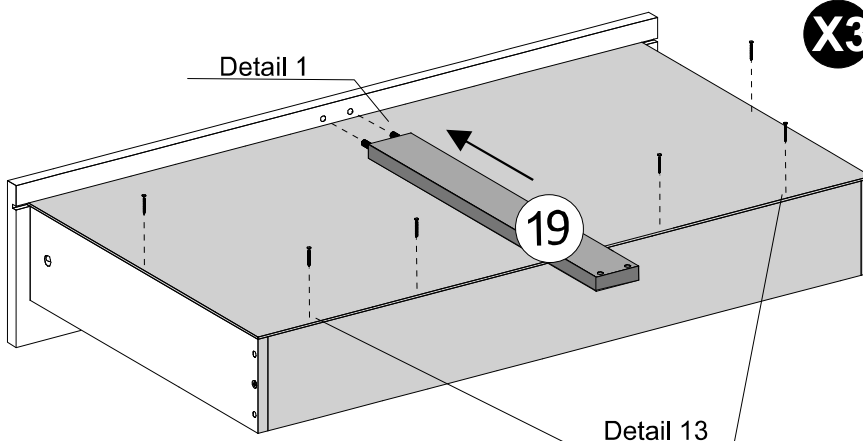
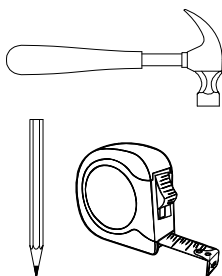

Detail 1

Detail 13

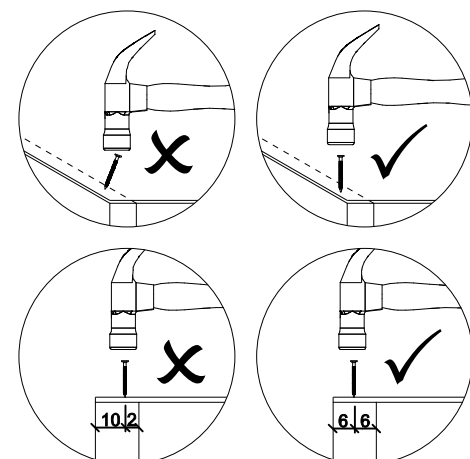

STEP 19

PARTS REQUIRED

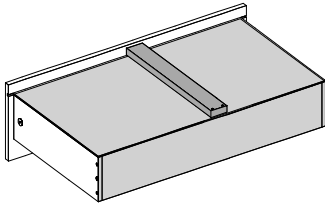

HARDWARE REQUIRED

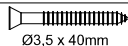
C	 Ø4,0 x 14mm	12
E	 Ø3,5 x 40mm	06
Q	LEFT	03
Q	RIGHT	03

TOOLS REQUIRED

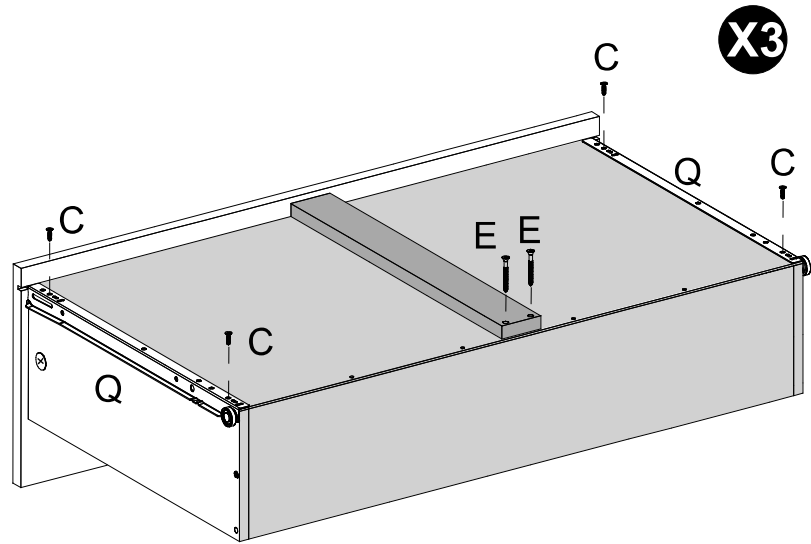
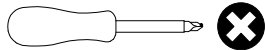

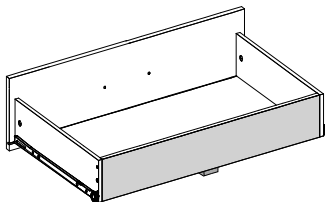

STEP 20

PARTS REQUIRED



HARDWARE REQUIRED

D	 4 x 22	06
T		03
V		06

TOOLS REQUIRED

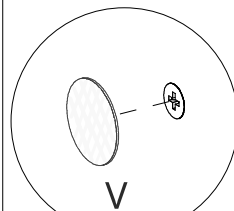
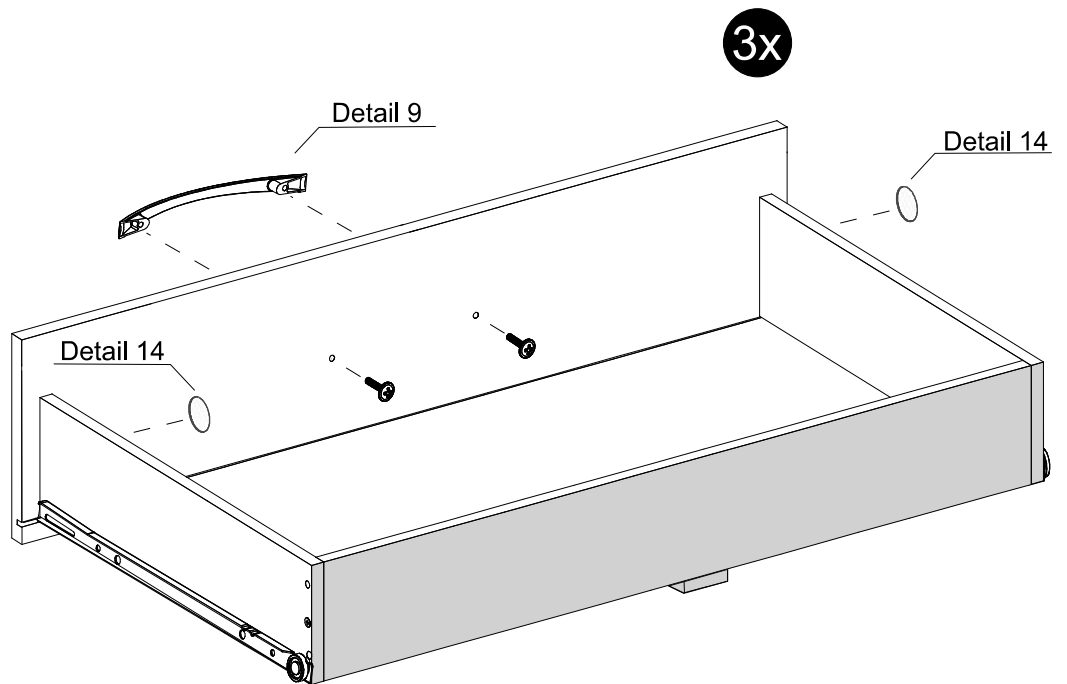
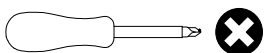

Detail 14

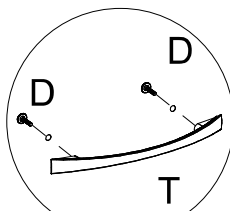

Detail 9

STEP 21

PARTS REQUIRED

6 - DRAWER SIDE x6

7 - DRAWER BACK PANEL x3

HARDWARE REQUIRED

F  04
Ø4 x 50

TOOLS REQUIRED

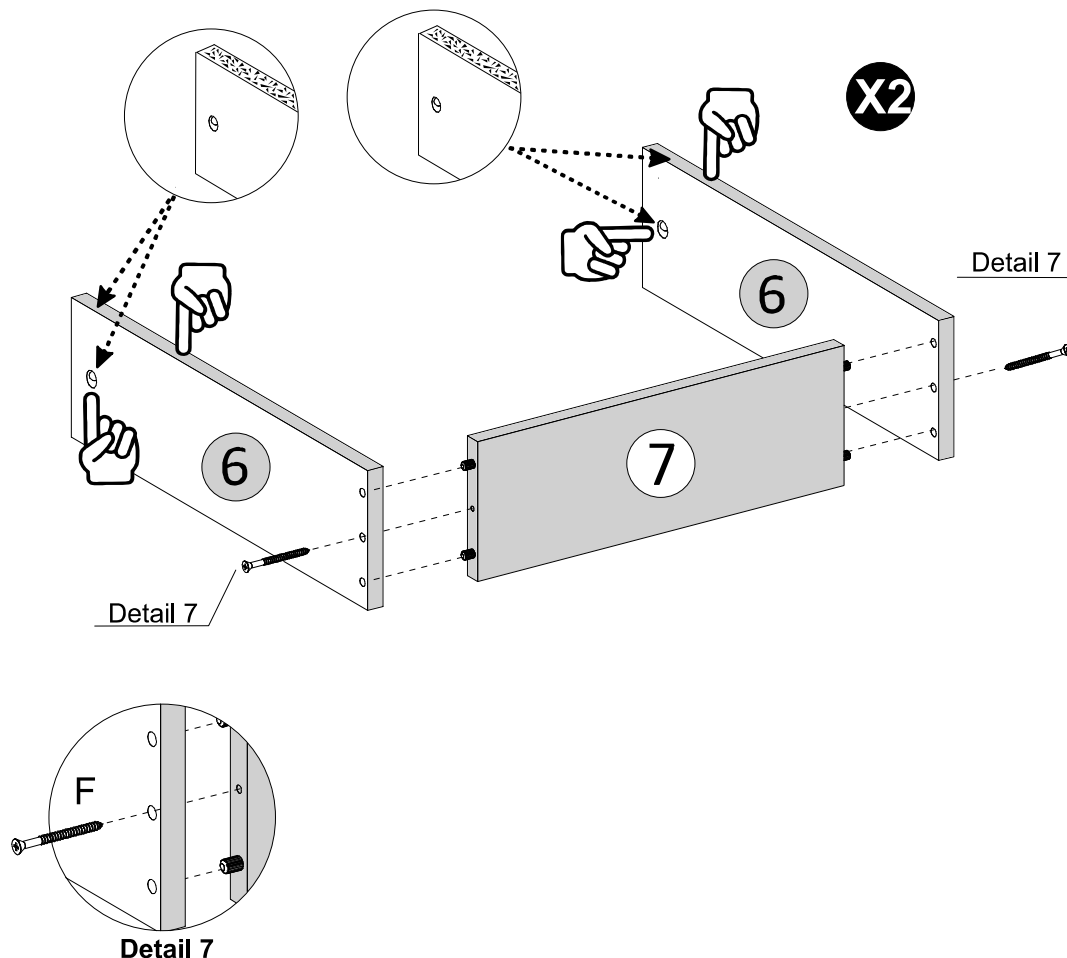
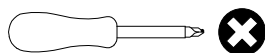

STEP 22

PARTS REQUIRED

5 - SMALL DRAWER FRONT x3

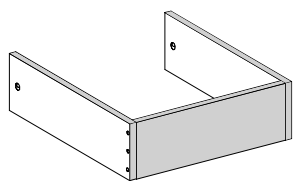

HARDWARE REQUIRED

J  04

P  01
GLUE

TOOLS REQUIRED

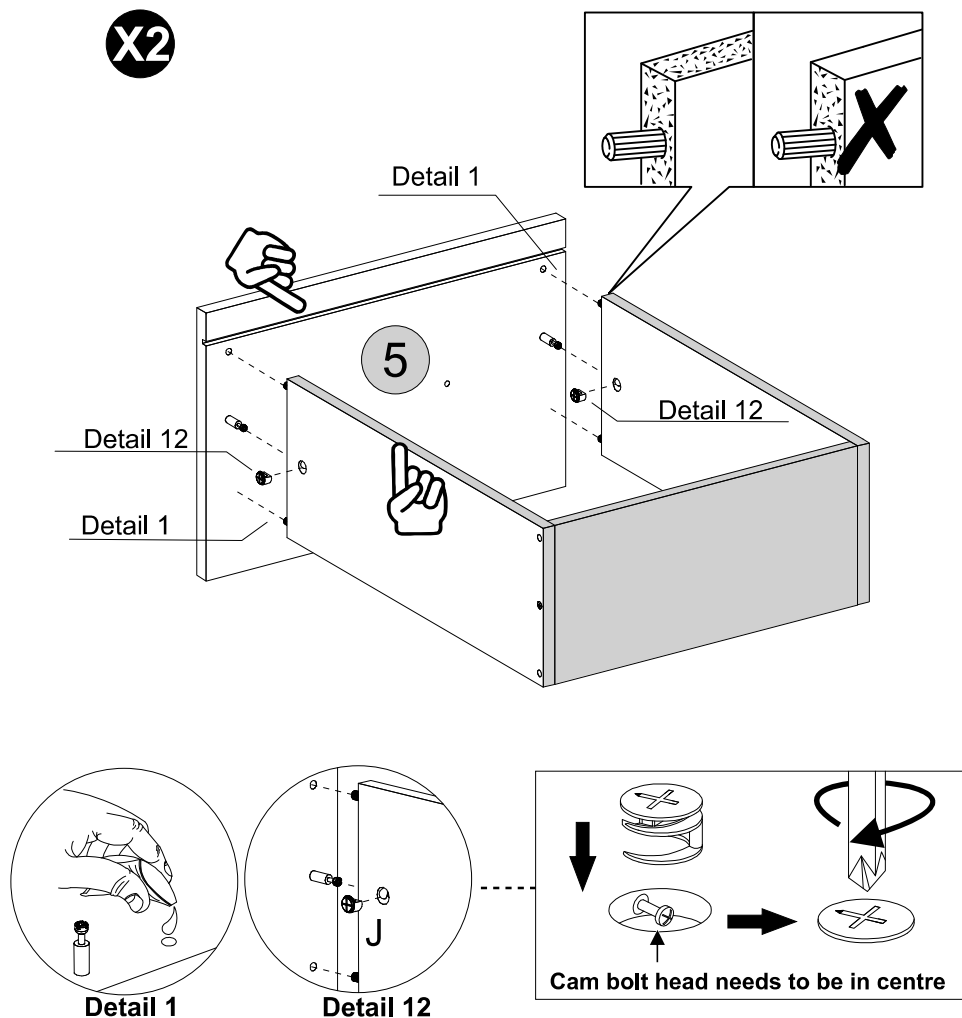
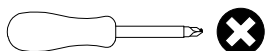

STEP 23

PARTS REQUIRED

8 - DRAWER BOTTOM x2

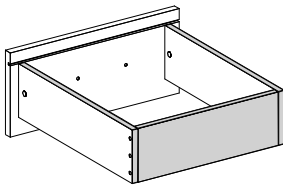

HARDWARE REQUIRED

H 10 x 10 08

TOOLS REQUIRED

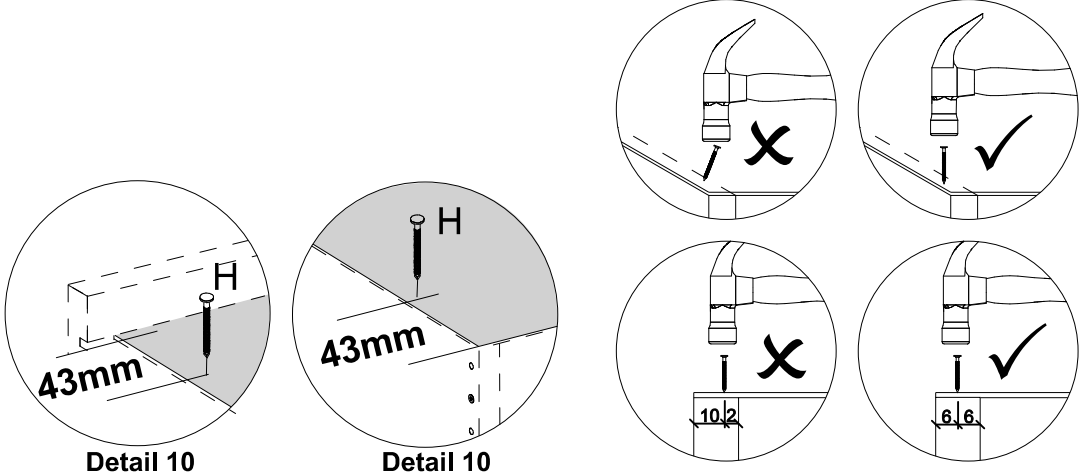
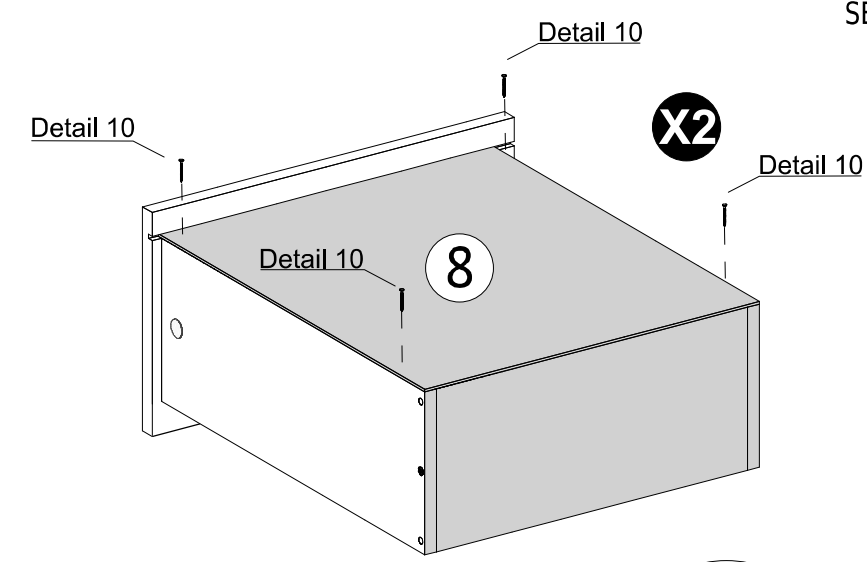
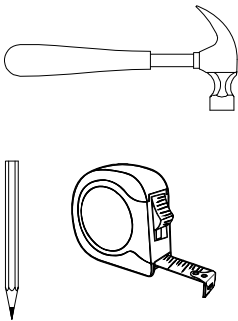

STEP 24

PARTS REQUIRED

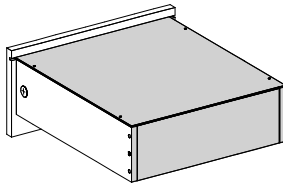

HARDWARE REQUIRED

H 10 x 10 08

TOOLS REQUIRED

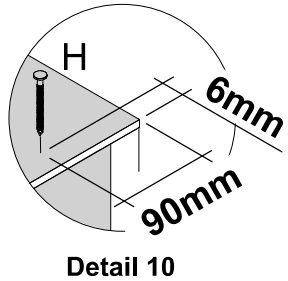
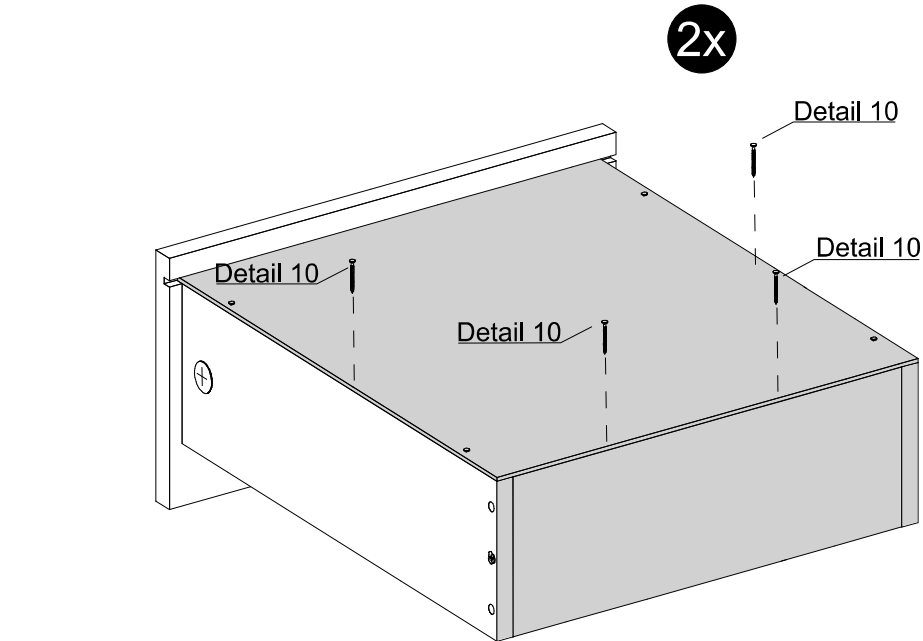
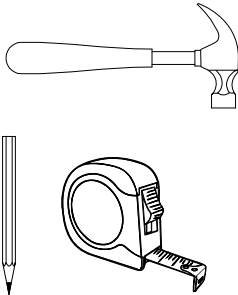

STEP 25

PARTS REQUIRED

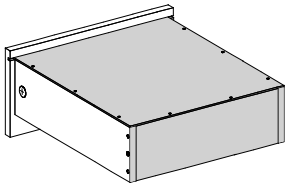

HARDWARE REQUIRED

C	 Ø4.0 x 14mm	08
---	---	----

Q	LEFT	02
---	------	----

Q	RIGHT	02
---	-------	----

TOOLS REQUIRED

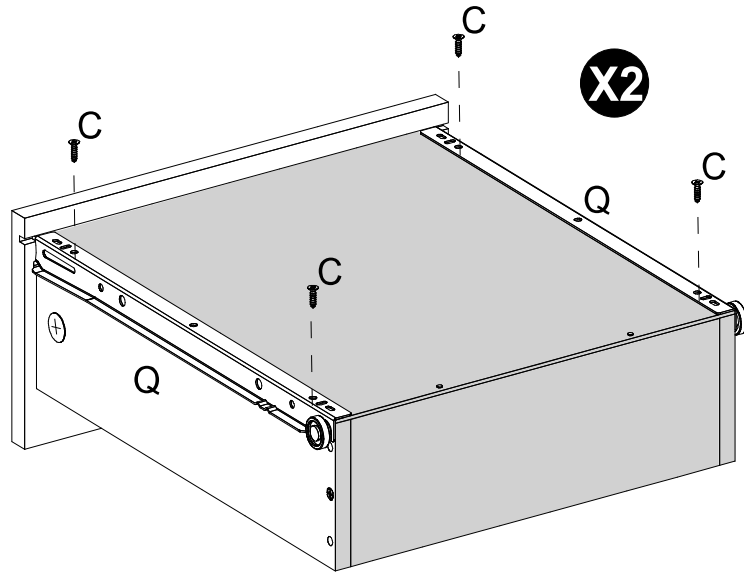
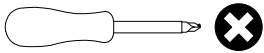

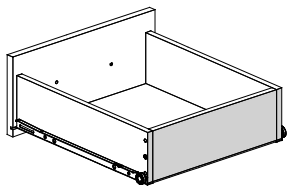

STEP 26

PARTS REQUIRED



HARDWARE REQUIRED

D	 4 x 22	04
---	--	----

V		04
---	---	----

T		02
---	---	----

TOOLS REQUIRED

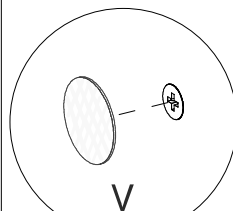
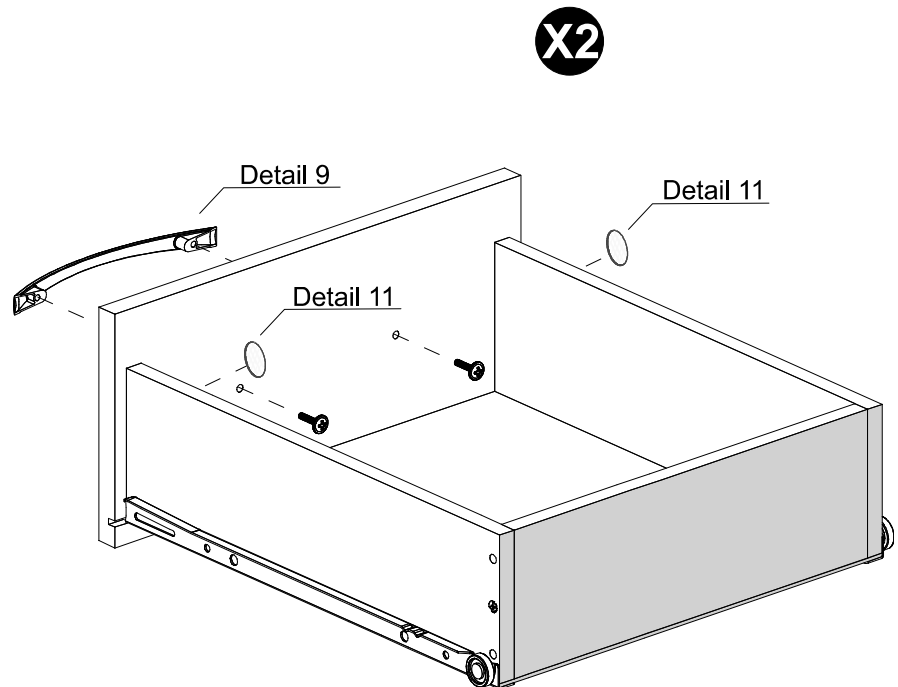
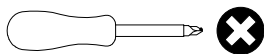

Detail 11

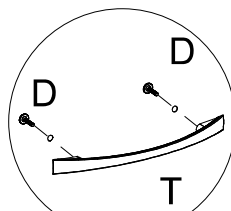

Detail 9

STEP 27

PARTS REQUIRED

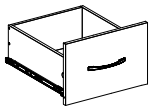
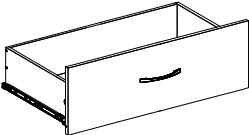
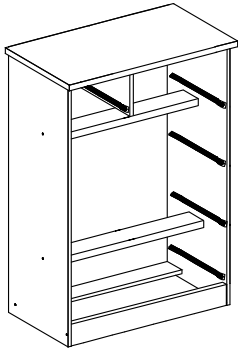

HARDWARE REQUIRED

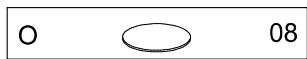

TOOLS REQUIRED

See the last page

See the last page

Detail 14

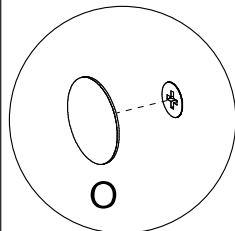

Detail 14

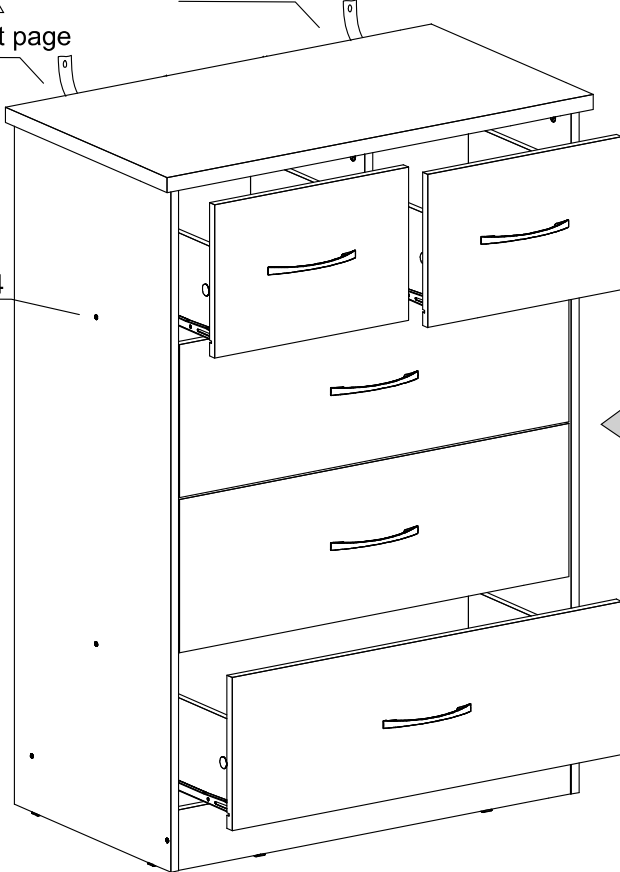

STEP 28

PARTS REQUIRED

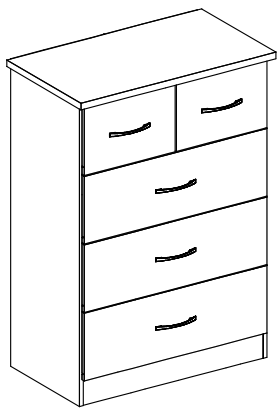

HARDWARE REQUIRED

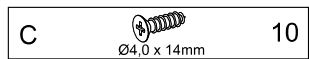

TOOLS REQUIRED

Detail 15

Detail 15

Detail 15

Detail 15

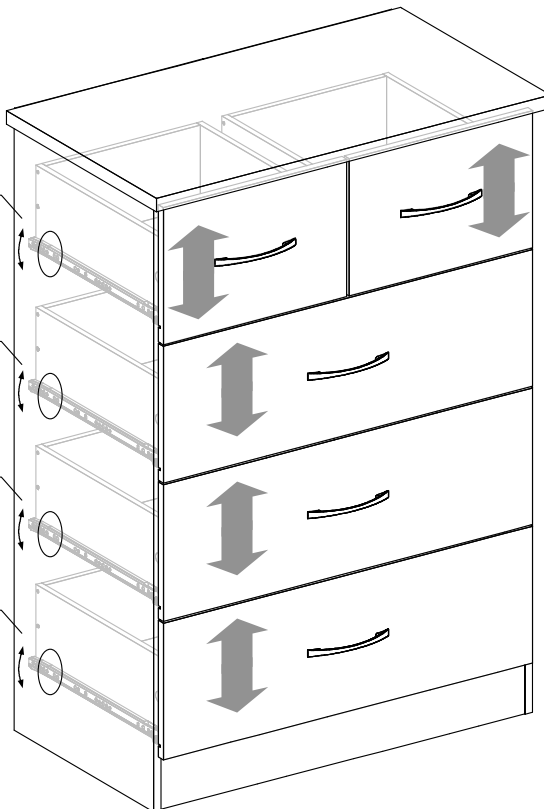

TIP
If desired, after assembly use an alcohol cleaner to erase the number printed on the parts.

Drawer Adjustment

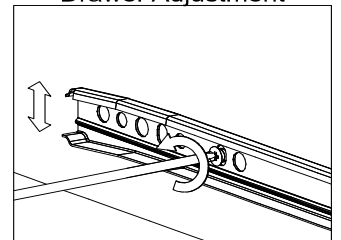

Right Side

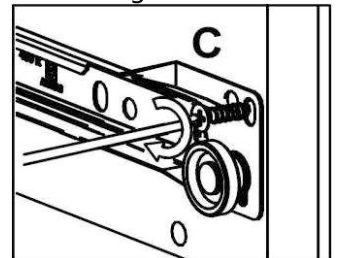

Left Side

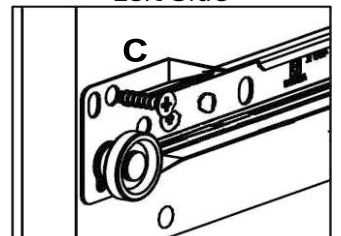

Detail 15

WARNING

Serious or fatal injuries can occur from furniture tipping over. To prevent the furniture from tipping over we recommend that it is permanently fixed to the wall.

Wall fixings are not supplied with this product as different wall materials require different types of fixing devices. Please make sure you use fixings suitable for the walls in your home.

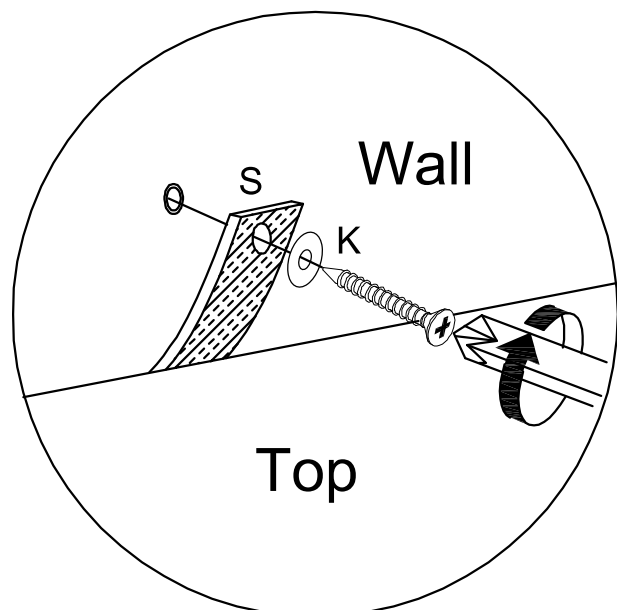
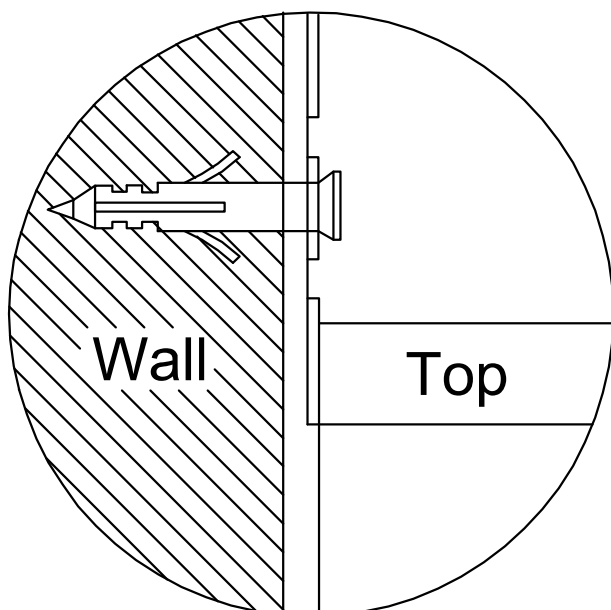
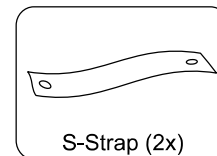
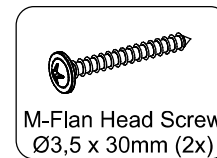
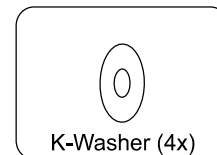
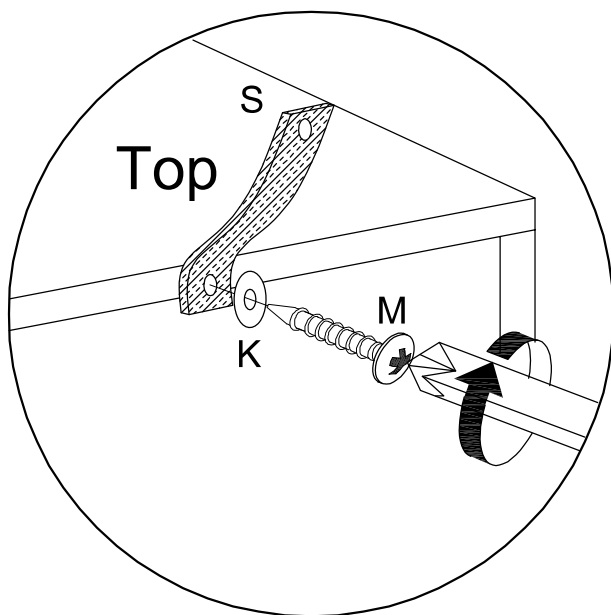

NEVADA 3 DRAWER BEDSIDE ASSEMBLY INSTRUCTIONS

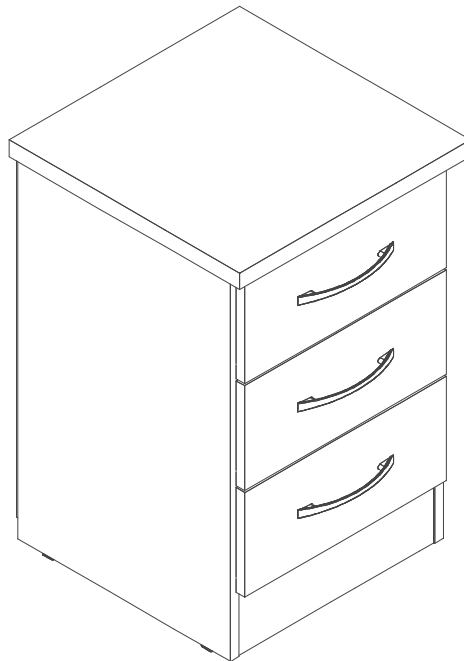

IMPORTANT FOR DOMESTIC USE ONLY

PLEASE READ BEFORE YOU CONTINUE FURTHER

CARE AND MAINTENANCE

- After unpacking this product please keep the original packaging in case it needs to be returned for any reason.
- Please ensure all fittings and parts are present before commencing with assembly.
 - Never drag or push products as this could cause damage to the joints making it inferior.
 - We strongly recommend that you keep children away from your work area.
 - We recommend that you lay a blanket or sheet on the floor to avoid damage to both your floor and the product.
 - Assemble this product as close to its final position as possible.
 - Do not place this product next to a radiator or in direct sunlight.
 - Do not drag or push items across your high gloss furniture as this may cause the surface to scratch
 - Wood is a natural product and may expand if subjected to damp and may shrink or crack if subjected to heat. Therefore it is recommended that room temperature is maintained, with no sudden temperature fluctuations.
 - Make sure any spillage is wiped off immediately.
 - Do not place hot or chilled items directly on to the surface, use a place mat or marking will occur.
 - For general cleaning use a soft cotton or micro fibre cloth, and do not use detergents of any kind.
 - From time to time it may be necessary to tighten fittings, regular inspections should be carried out.
 - Do not place on a wet or damp floor as staining may occur to your floor.

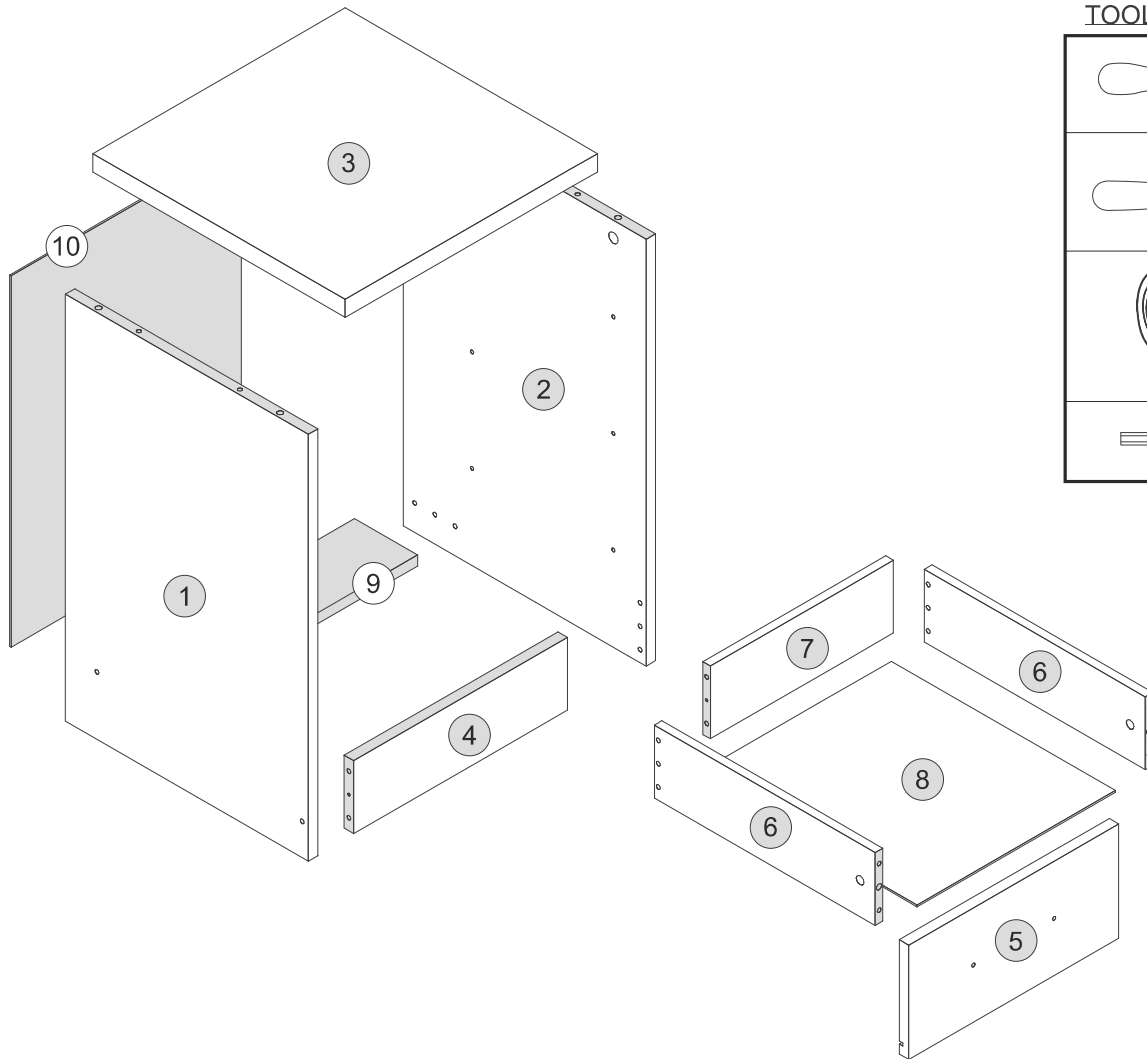

TOOLS REQUIRED

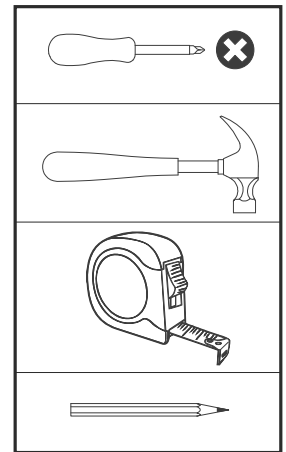









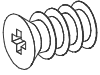
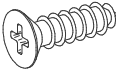
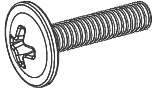

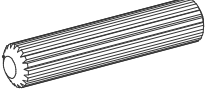

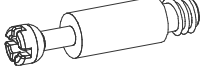
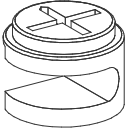
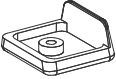
PARTS LIST

Please Note:
The below parts have all been stamped with the part number to help identify them during assembly.

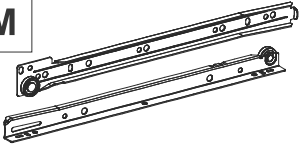
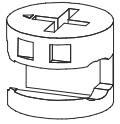
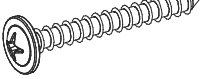
Part Number	Part Description	Quantity	Carton
01	Left Side Panel	1	1/1
02	Right Side Panel	1	1/1
03	Top Panel	1	1/1
04	Front Baseboard	1	1/1
05	Drawer Front	3	1/1
06	Drawer Side	6	1/1
07	Drawer Back Panel	3	1/1
08	Drawer Bottom	3	1/1
09	Back Baseboard	1	1/1
10	Back Panel	1	1/1

FITTINGS LIST

<p>A</p>  <p>Flat Head Screw 2/+ Ø6,0 x 10mm (12x)</p>	<p>B</p>  <p>Flat Head Screw 2/+ Ø4,0 x 14mm (18x)</p>	<p>C</p>  <p>Flan Head Screw Ø4,0 x 20mm (6x)</p>	<p>D</p>  <p>Flat Head Screw 1/+ Ø4,0 x 50mm (10x)</p>
<p>E</p>  <p>2/+ Dowel Ø6,0 x 30mm (36x)</p>	<p>F</p>  <p>2/+ Nail 10x10 Ringed-1,5x23mm (42x)</p>	<p>G</p>  <p>2/+ Cam Bolt (10x)</p>	<p>H</p>  <p>1/+ Cam Nut Ø12x8 8mm (6x)</p>
<p>I</p>  <p>1/+ Plastic Foot L 19x17x8mm Ø2 (4x)</p>	<p>J</p>  <p>2/+ Hole Plugs 19mm (4x)</p>	<p>K</p>  <p>Glue 10 Gr (2x)</p>	<p>L</p>  <p>Handle (3x)</p>
<p>M</p>  <p>Drawer Runners 350mm (3x)</p>	<p>N</p>  <p>1/+ Cam Nut Ø14,9x11 mm (4x)</p>	<p>O</p>  <p>1/+ Flan Head Screw Ø3,5 x 30mm (1x)</p>	<p>P</p>  <p>Strap 200x20x1MM (1x)</p>
<p>Q</p>  <p>1/+ Washer Ø16x7 (2x)</p>	<p>R</p>  <p>+1/2 Hole Plugs Lineo 19mm (6x)</p>		

TIPS FOR FITTINGS CAM-LOCKS

WHEN FITTING CAM NUT. ENSURE STARTING POSITION IS CORRECT BEFORE YOU INSERT CONNECTING CAM BOLT TURN CLOCKWISE UNTIL SECURE



↑
CORRECT



↓
WRONG

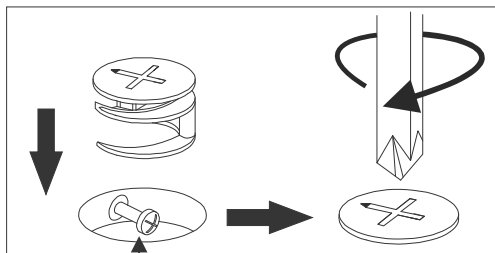

Cam bolt head needs to be in centre

CAMBOLT

Tighten until shoulder in flush with panel. Do not overtighten or undertighten (see example below)

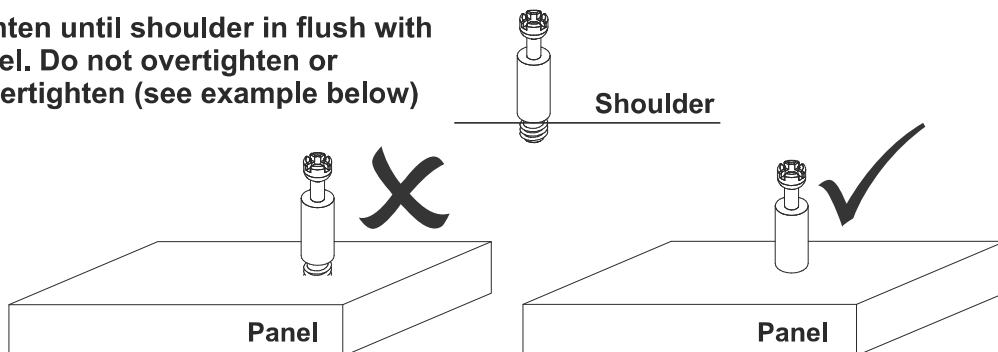



STEP 1

PARTS REQUIRED

1 - LEFT SIDE PANEL x1

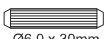
HARDWARE REQUIRED

E  02
Ø6,0 x 30mm

F  02
10 x 10

I  02

K  01

TOOLS REQUIRED

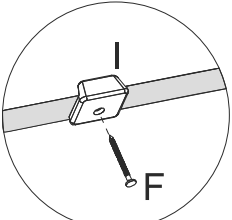
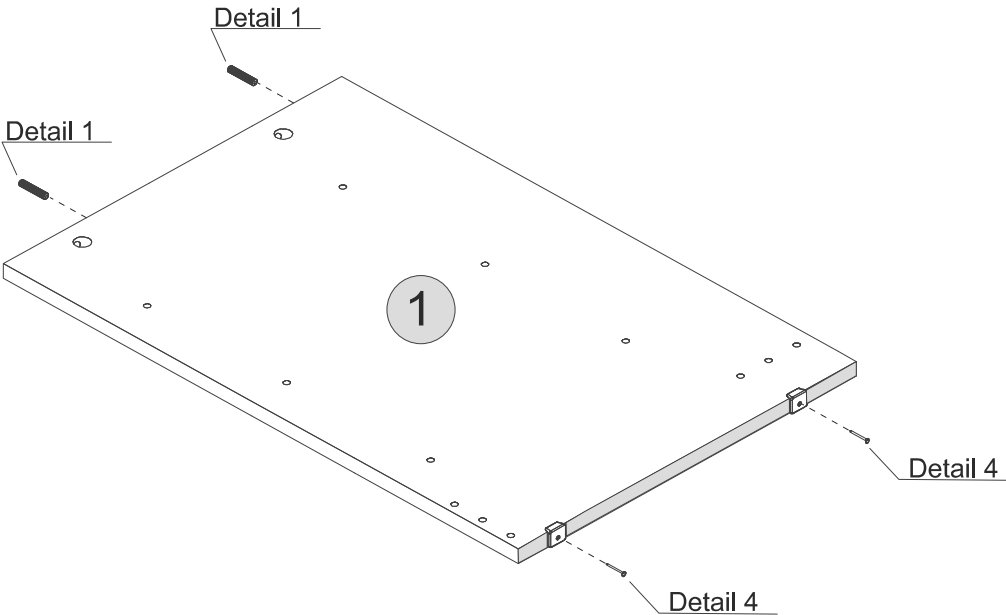
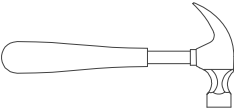

Detail 1

Detail 4

STEP 2

PARTS REQUIRED

2 - RIGHT SIDE PANEL x1

HARDWARE REQUIRED

E  02
Ø6,0 x 30mm

F  02
10 x 10

I  02

K  01

TOOLS REQUIRED

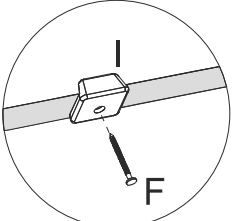
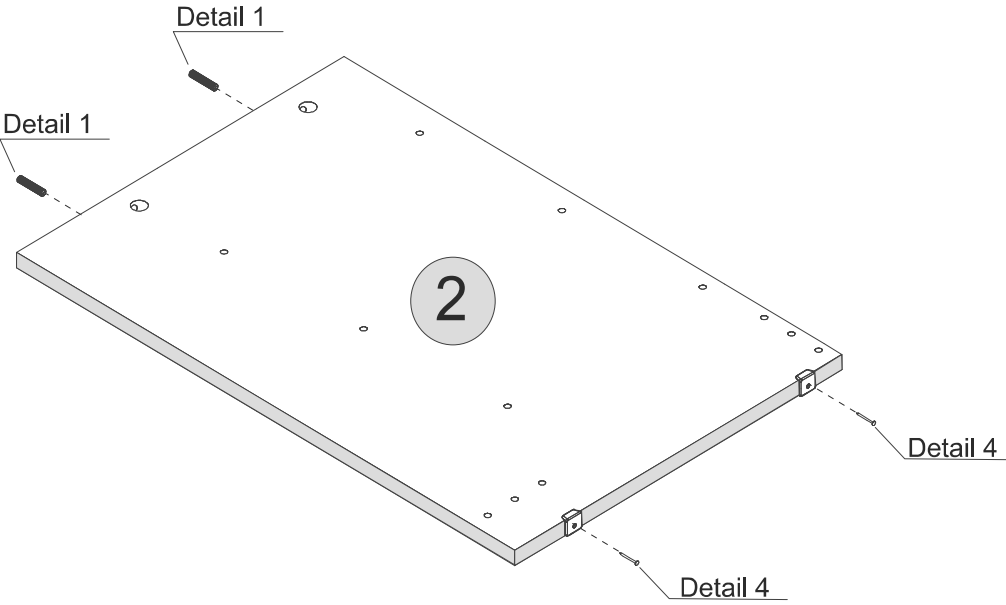
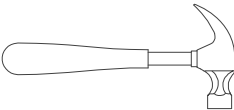

Detail 1

Detail 4

STEP 3

PARTS REQUIRED

2 - RIGHT SIDE PANEL x1

HARDWARE REQUIRED

A  06
Ø6.0 x 10mm

B  03
Ø4.0 x 14mm

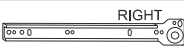
M  03
RIGHT

TOOLS REQUIRED

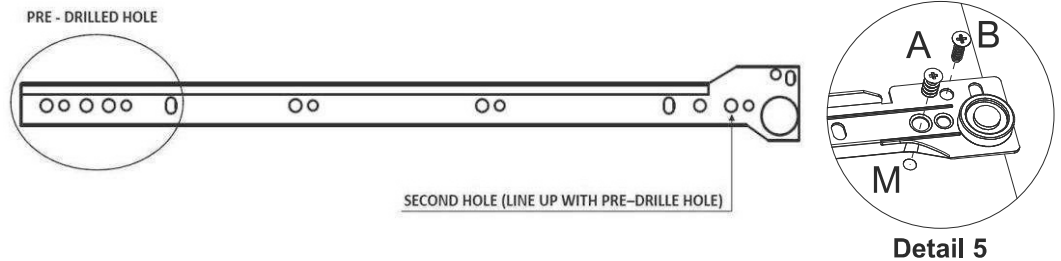
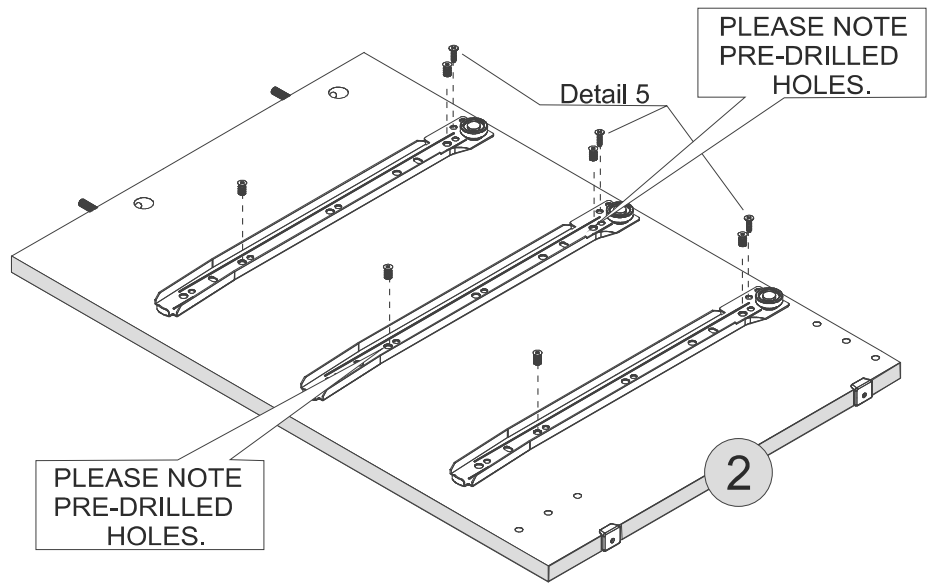



STEP 4

PARTS REQUIRED

1 - LEFT SIDE PANEL x1

HARDWARE REQUIRED

A  06
Ø6.0 x 10mm

B  03
Ø4.0 x 14mm

M  03
LEFT

TOOLS REQUIRED

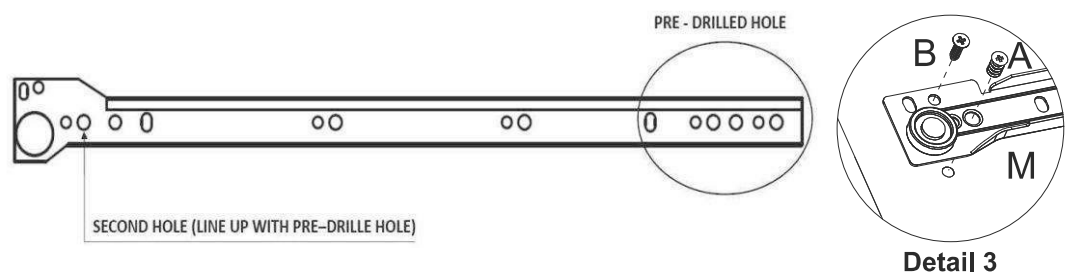
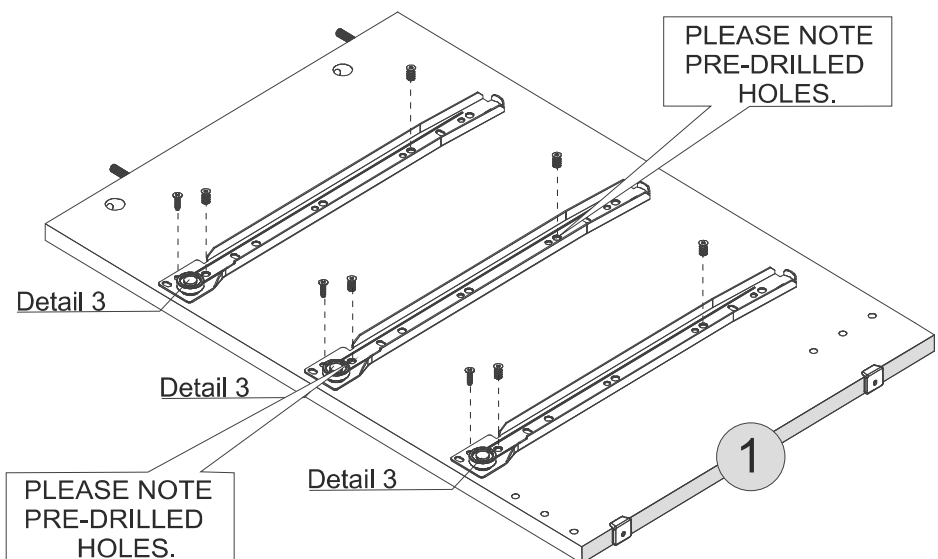
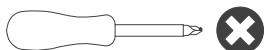

STEP 5

PARTS REQUIRED

9 - BACK BASEBOARD x1

4 - FRONT BASEBOARD x1

HARDWARE REQUIRED

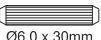
E  08
Ø6,0 x 30mm

K  01
GLUE

TOOLS REQUIRED

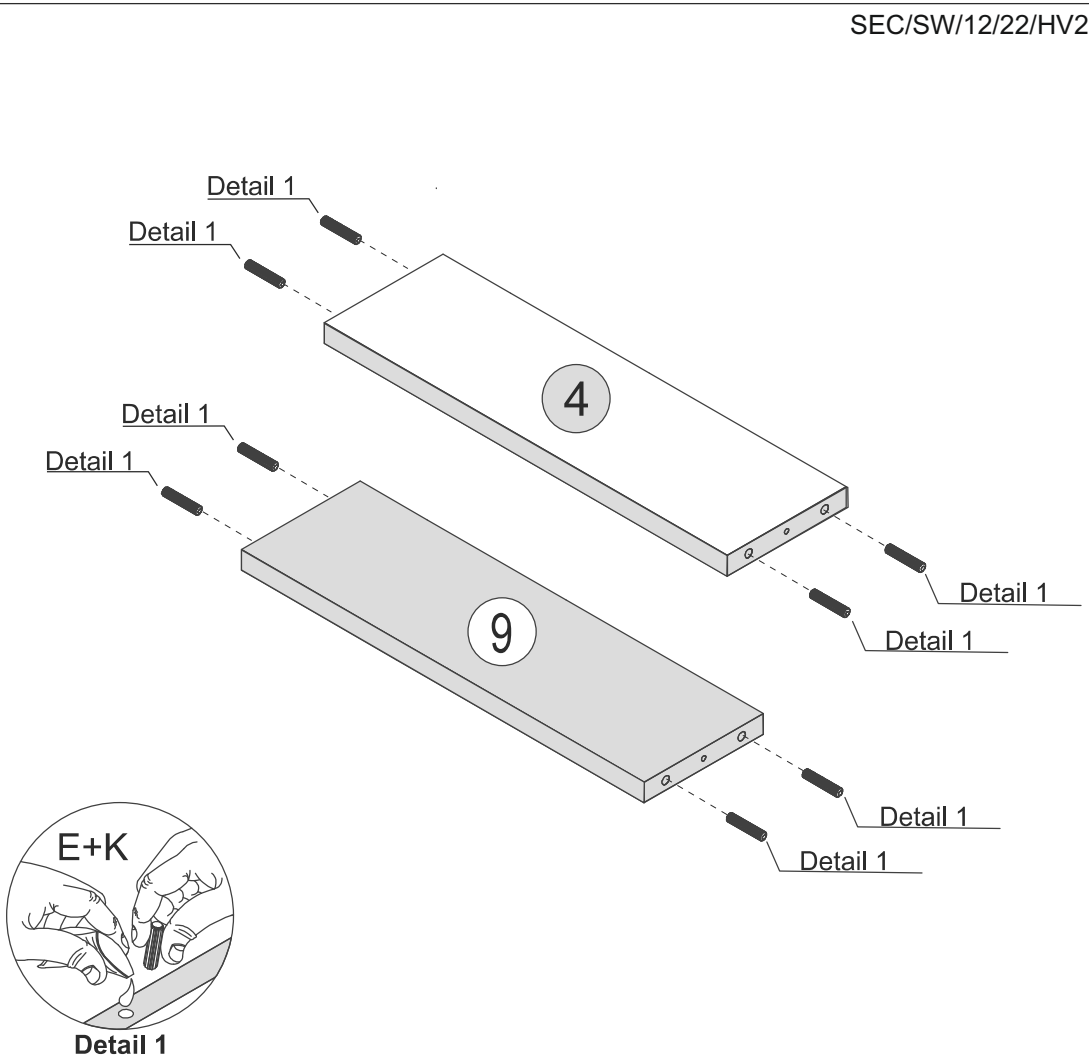

Detail 1

STEP 6

PARTS REQUIRED

2 - RIGHT SIDE PANEL x1

9 - BACK BASEBOARD x1

4 - FRONT BASEBOARD x1

HARDWARE REQUIRED

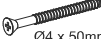
D  02
Ø4 x 50mm

K  01
GLUE

TOOLS REQUIRED

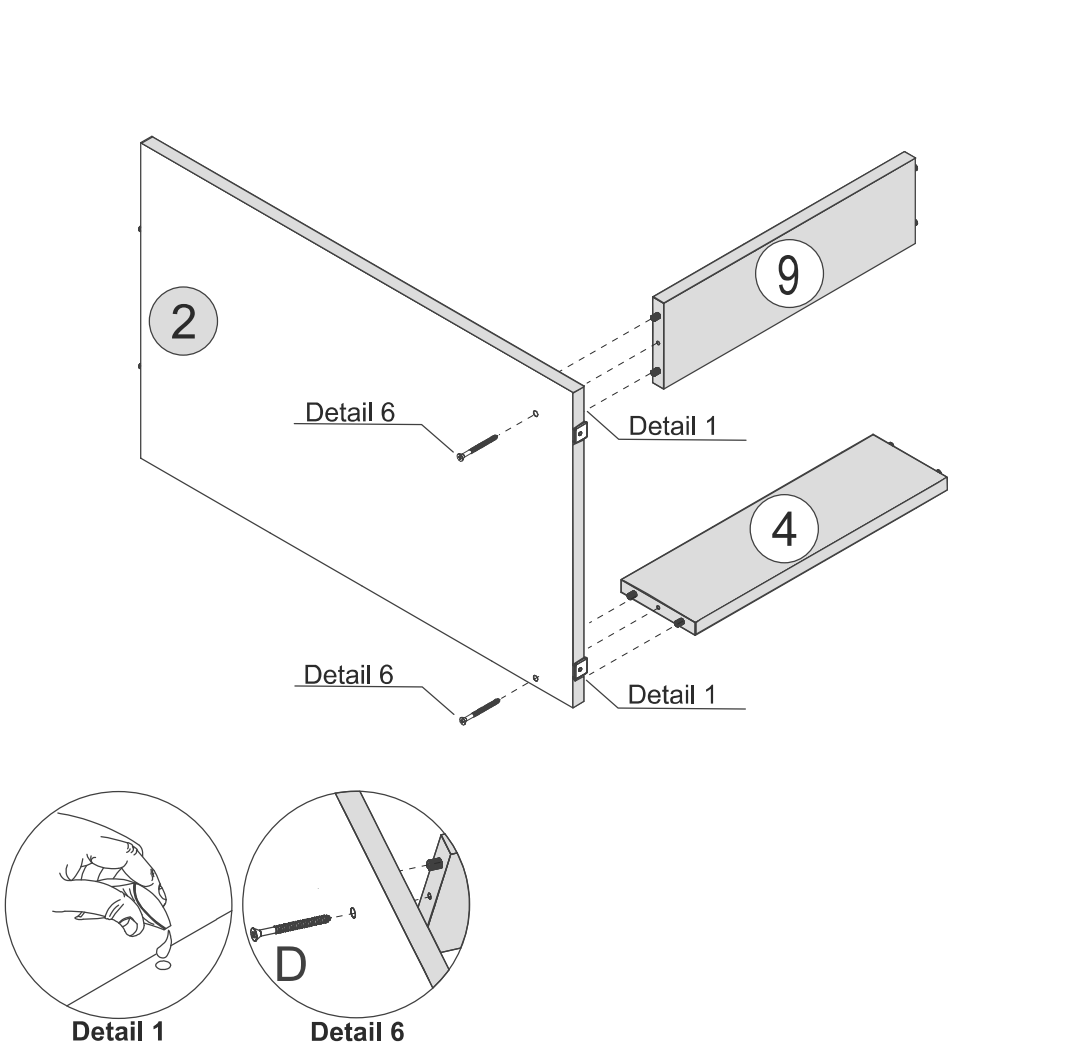
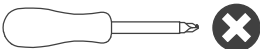

Detail 1

Detail 6

STEP 7

PARTS REQUIRED

1 - LEFT SIDE PANEL x1

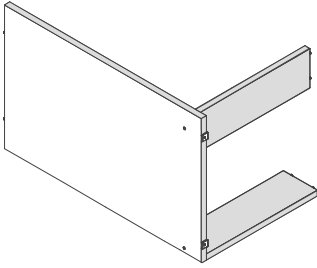

HARDWARE REQUIRED

D  02
Ø4 x 50mm

K  01
GLUE

TOOLS REQUIRED

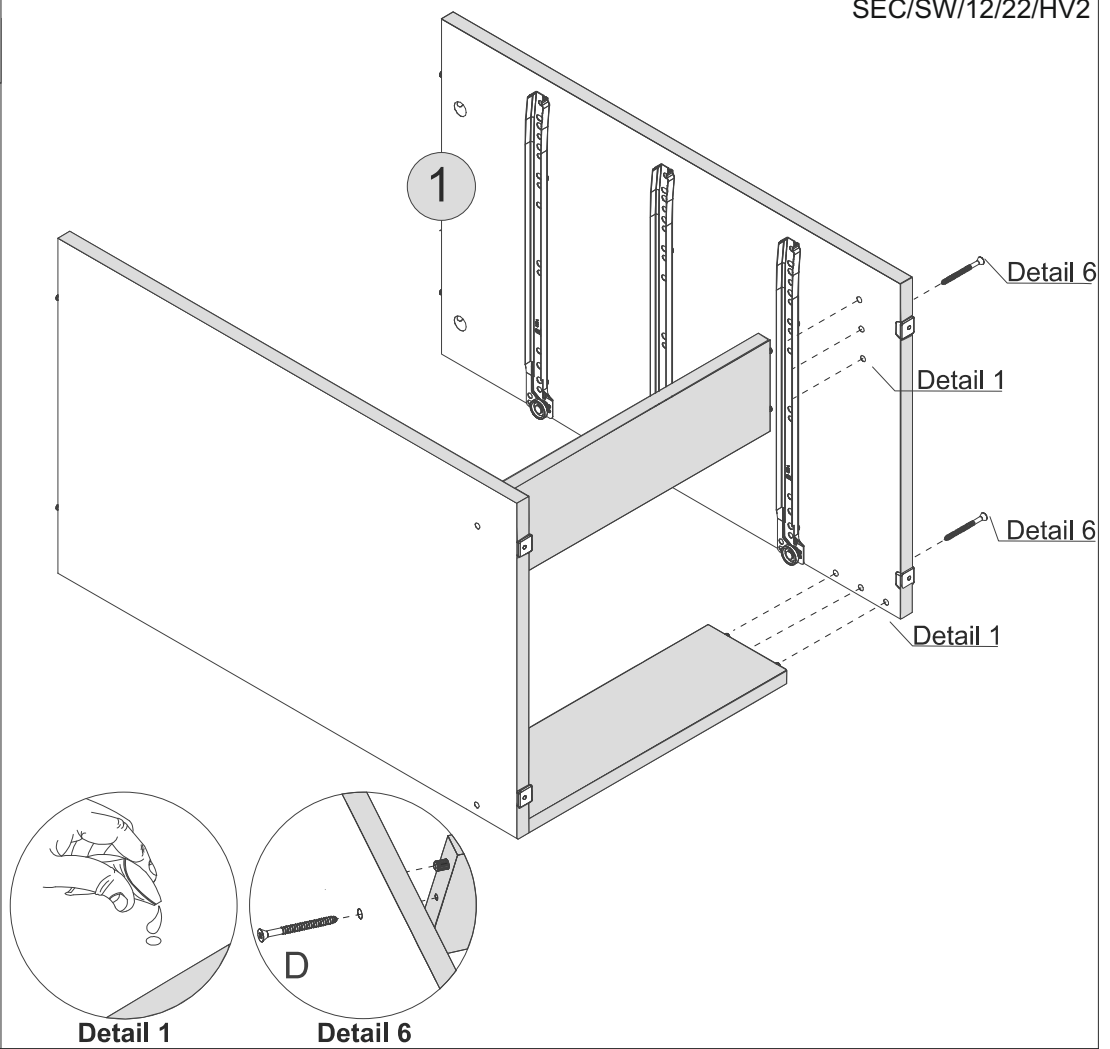
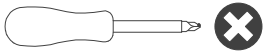

STEP 8

PARTS REQUIRED

3 - TOP PANEL x1

HARDWARE REQUIRED

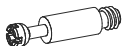
G  04

TOOLS REQUIRED

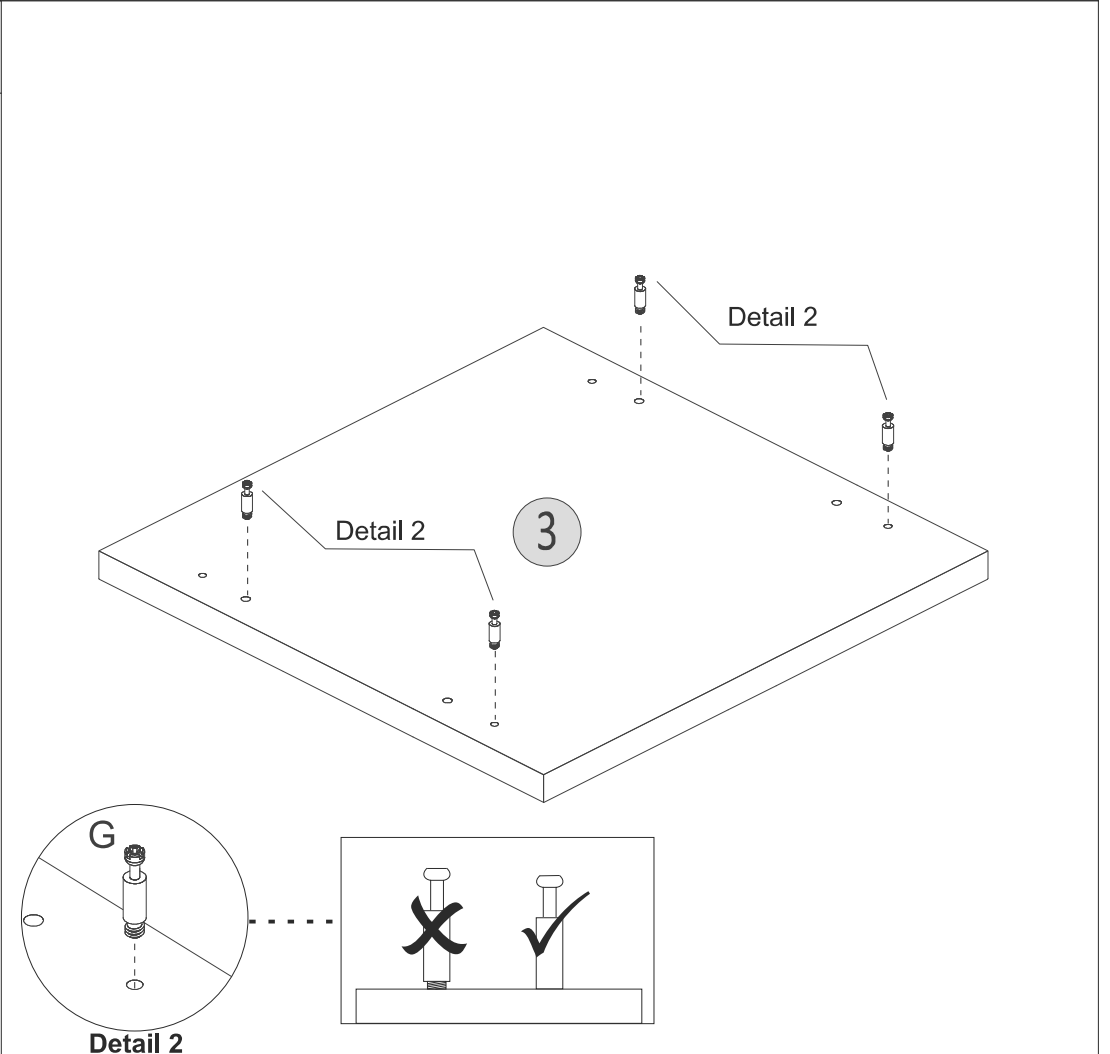
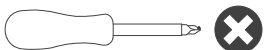

STEP 9

PARTS REQUIRED

3 - TOP PANEL x1

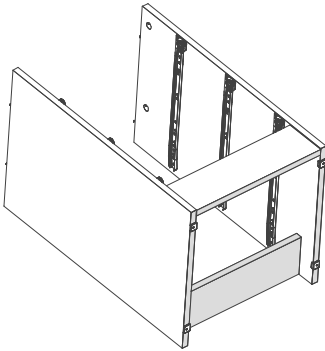

HARDWARE REQUIRED

K  01

N  04

TOOLS REQUIRED

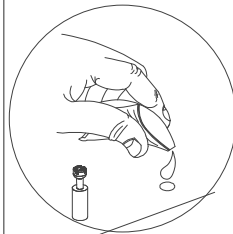
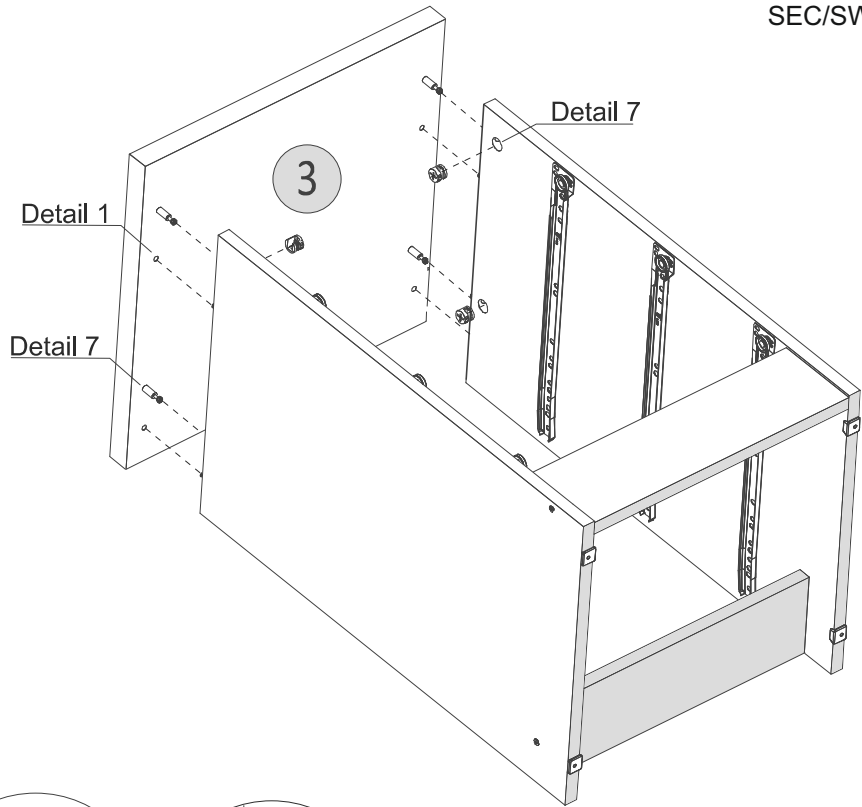
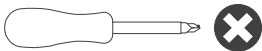

Detail 1

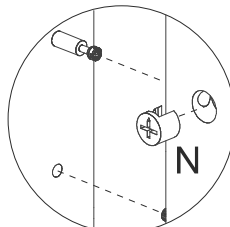

Detail 7

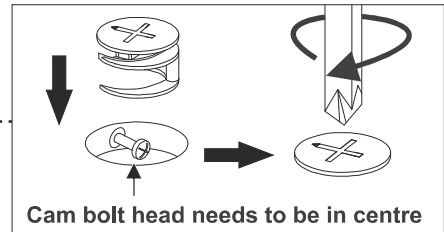

Cam bolt head needs to be in centre

STEP 10

PARTS REQUIRED

10 - BACK PANEL x1

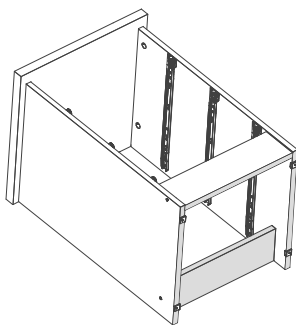

HARDWARE REQUIRED

F  14

TOOLS REQUIRED

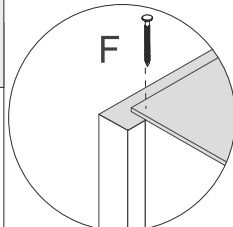
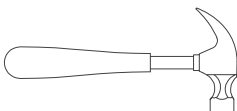

Detail 8

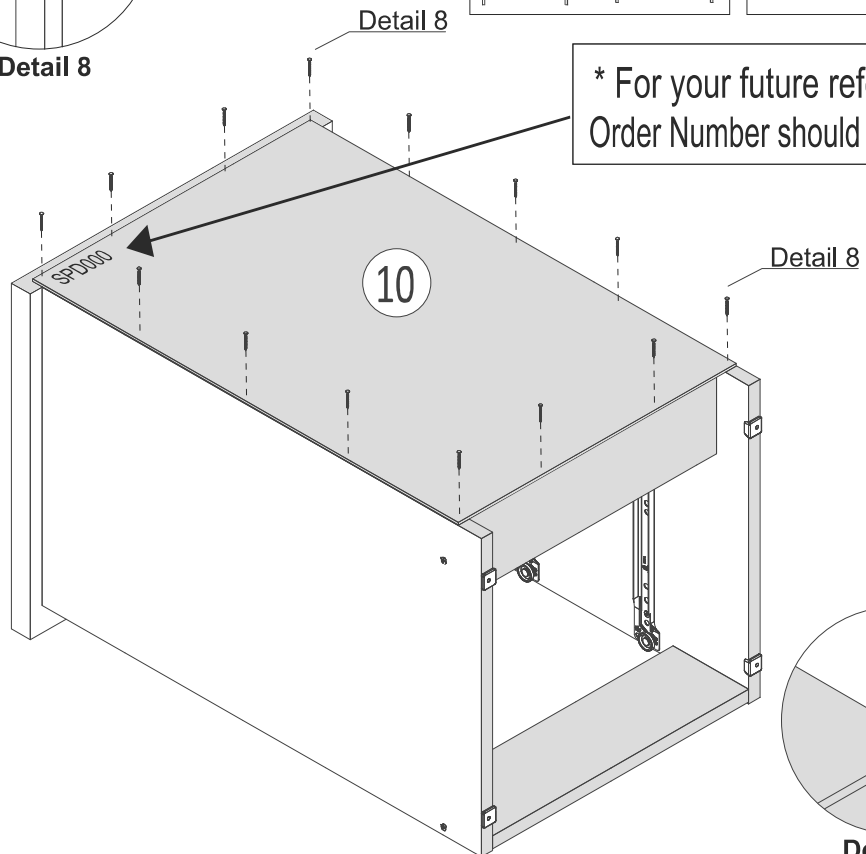
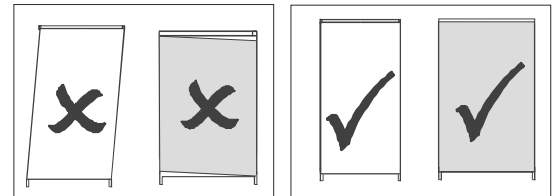

* For your future reference
Order Number should be here

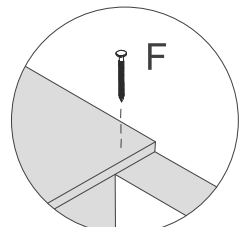

Detail 8

STEP 11

PARTS REQUIRED

6 - DRAWER SIDE x6

7 - DRAWER BACK PANEL x3

HARDWARE REQUIRED

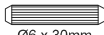
E  24
Ø6 x 30mm

K  01
GLUE

TOOLS REQUIRED

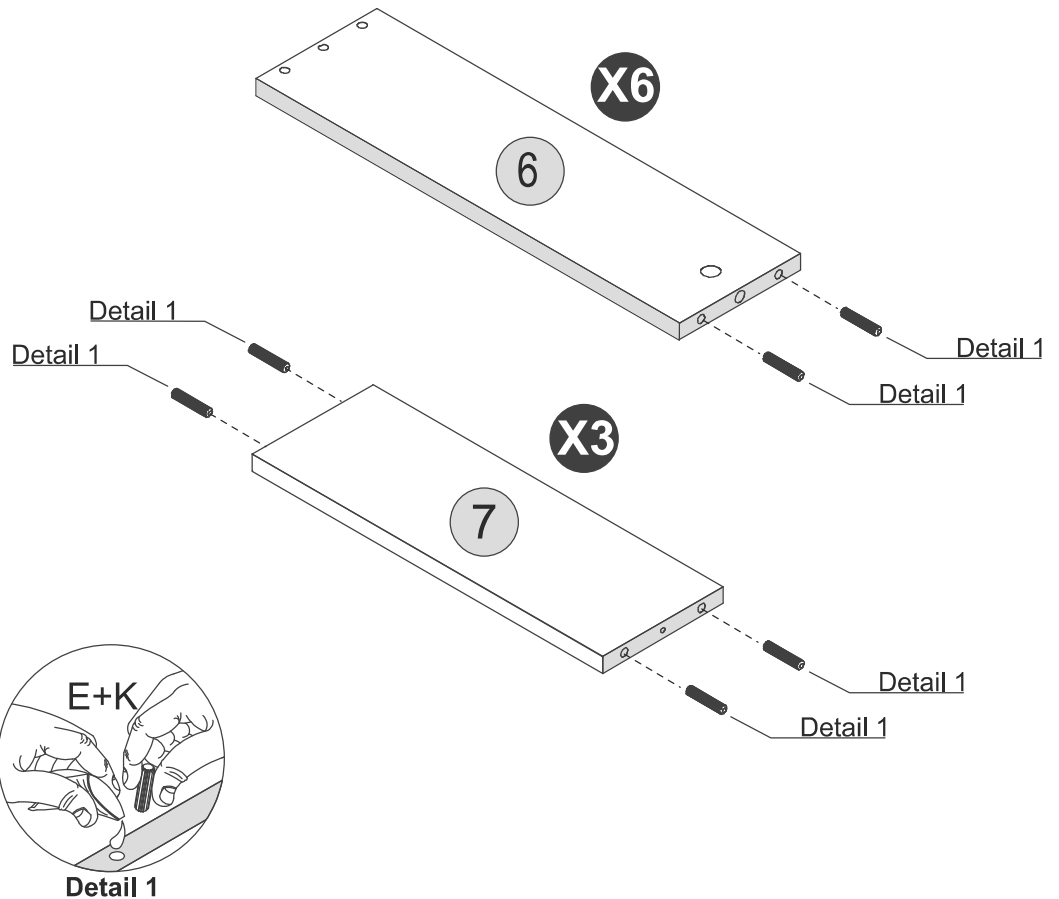

STEP 12

PARTS REQUIRED

5 - DRAWER FRONT x3

HARDWARE REQUIRED

G  06

TOOLS REQUIRED

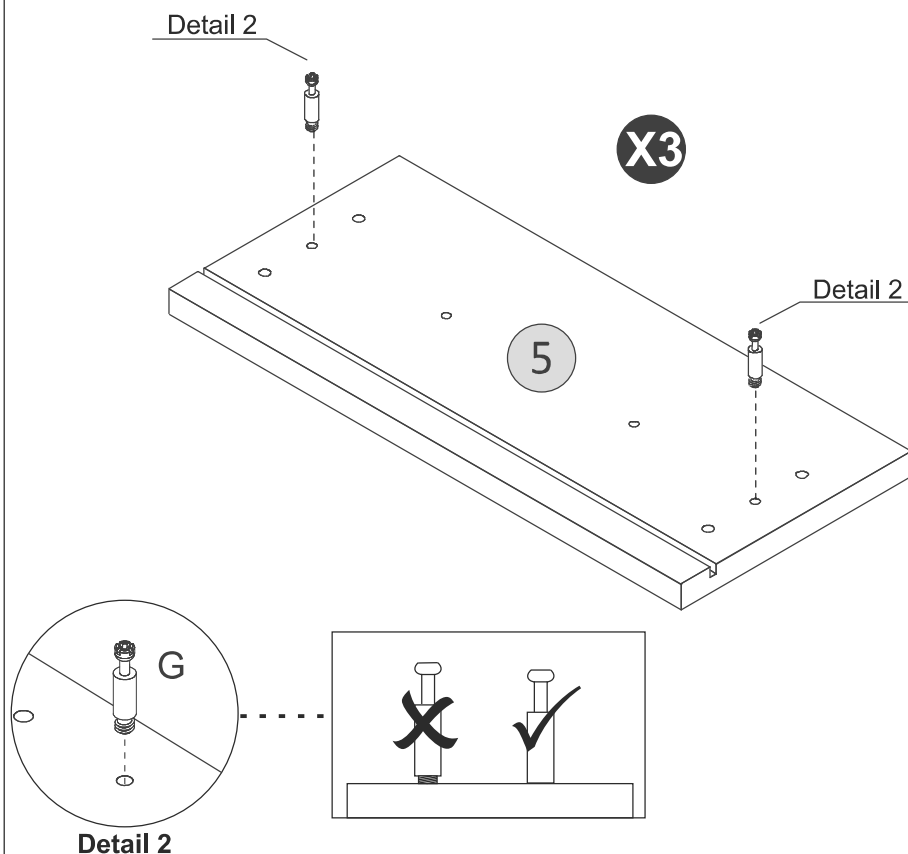

STEP 13

PARTS REQUIRED

6 - DRAWER SIDE x6

7 - DRAWER BACK PANEL x3

HARDWARE REQUIRED

D  06
Ø4 x 50mm

TOOLS REQUIRED

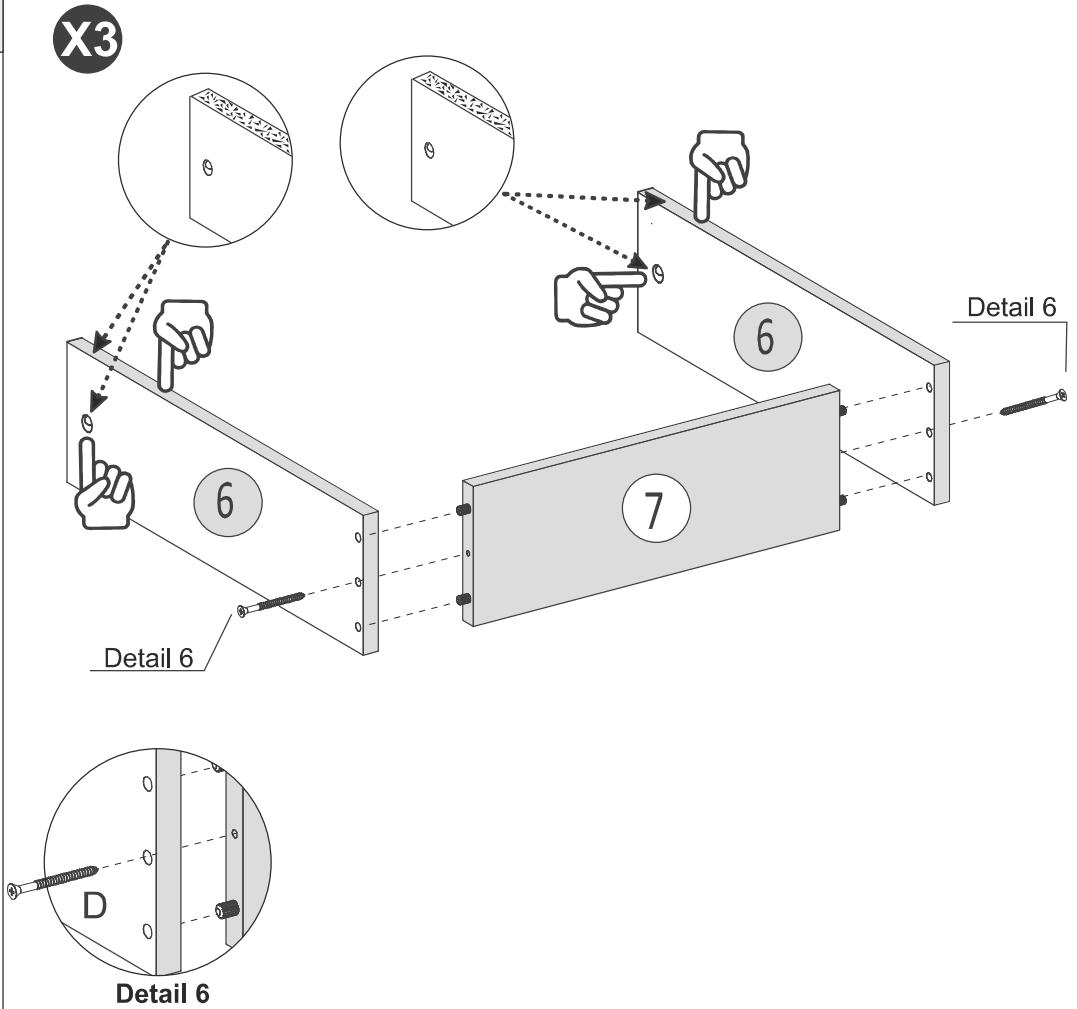
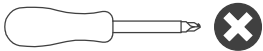

STEP 14

PARTS REQUIRED

5 - DRAWER FRONT x3

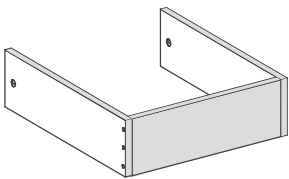

HARDWARE REQUIRED

H  06

K  01
GLUE

TOOLS REQUIRED

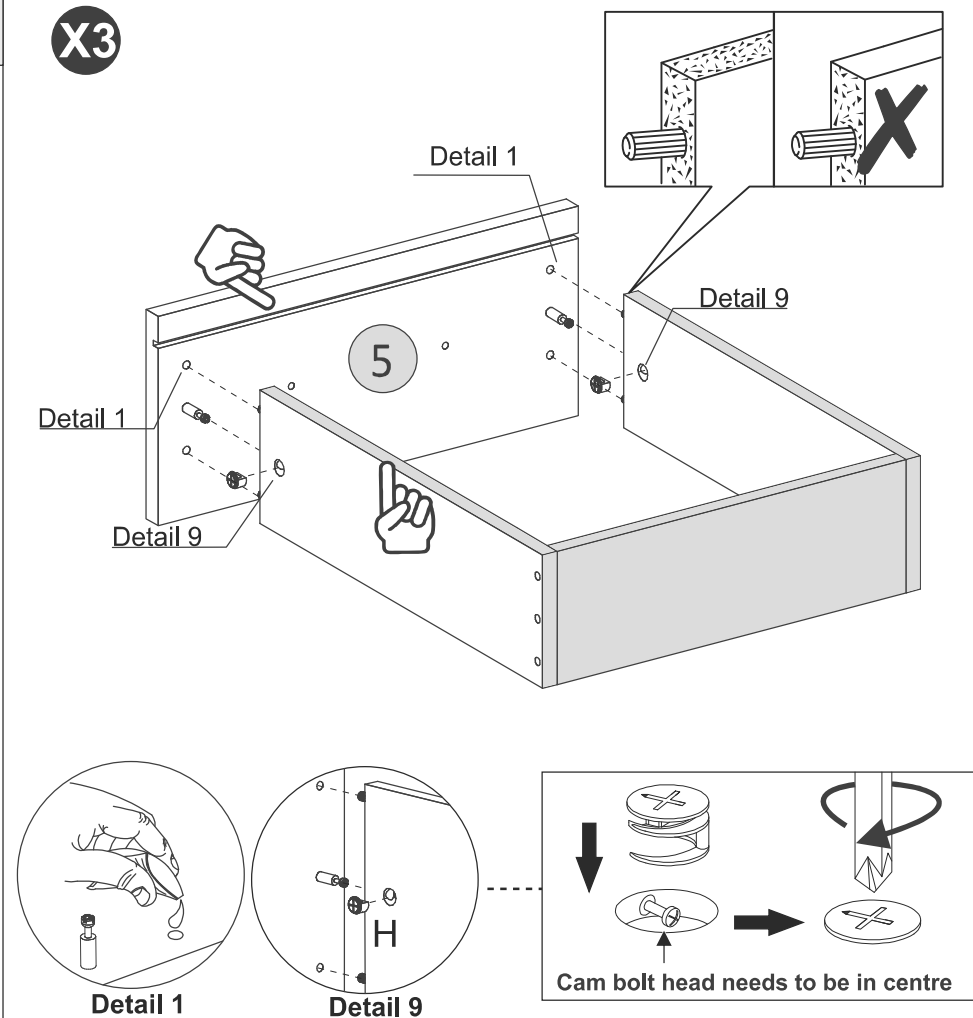
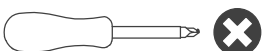

STEP 15

SEC/SW/12/22/HV2

PARTS REQUIRED

8 - DRAWER BOTTOM x3

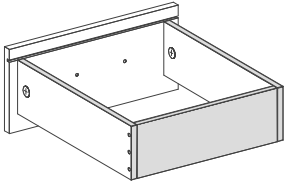

HARDWARE REQUIRED

F  12
10 x 10

TOOLS REQUIRED

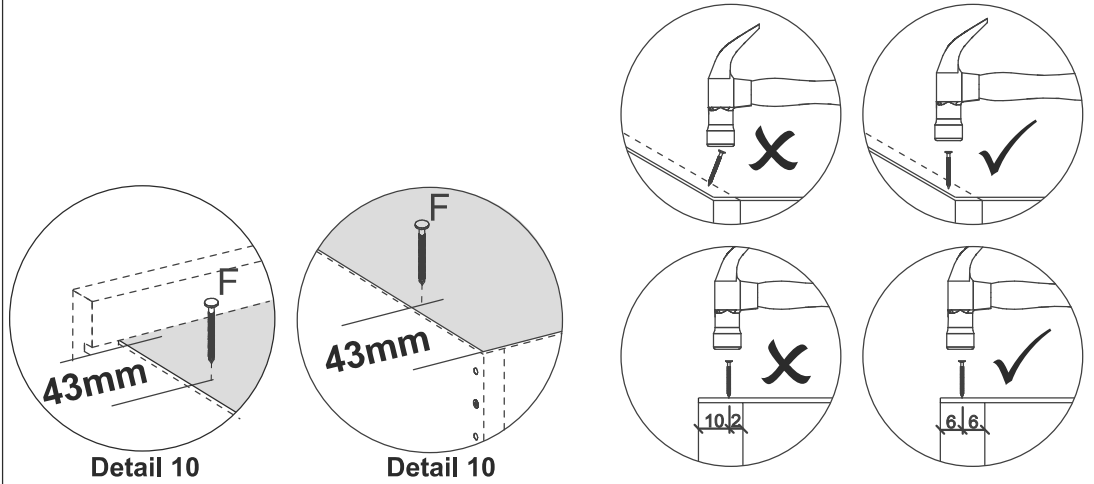
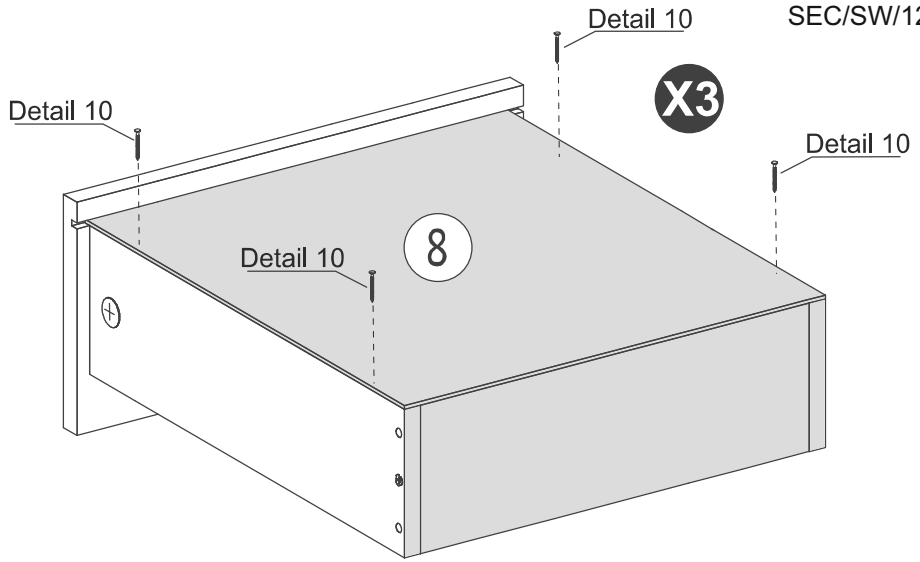
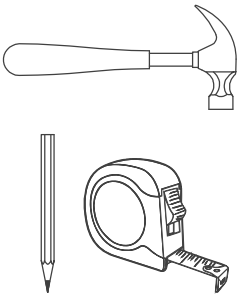

STEP 16

PARTS REQUIRED

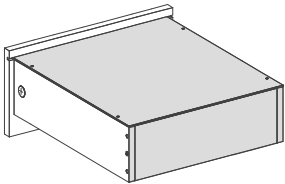

HARDWARE REQUIRED

F  12
10 x 10

TOOLS REQUIRED

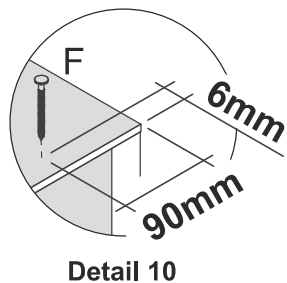
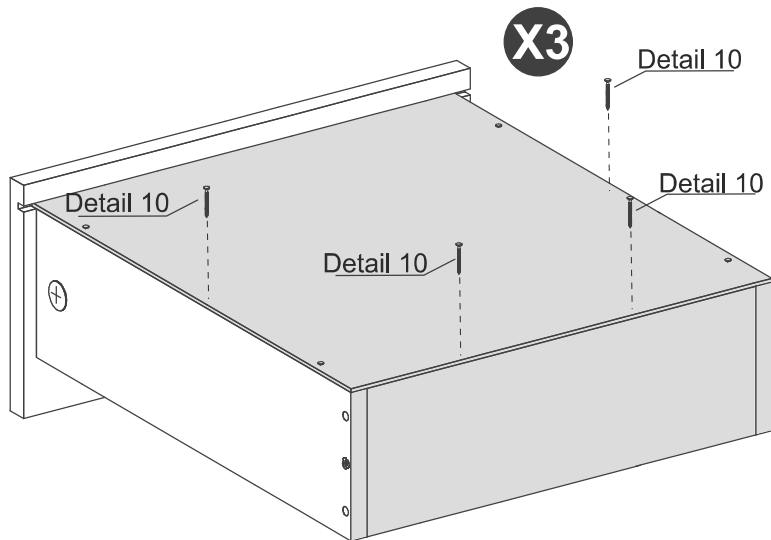
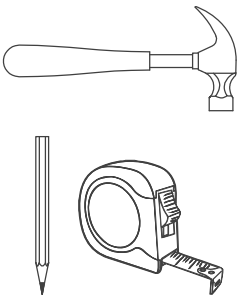

STEP 17

PARTS REQUIRED

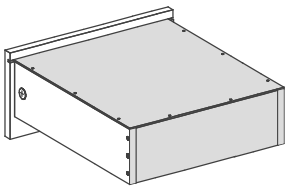

HARDWARE REQUIRED

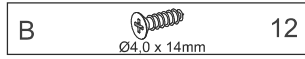

TOOLS REQUIRED

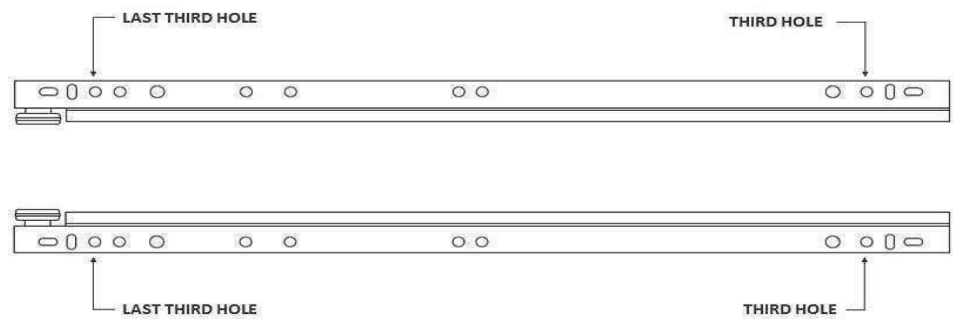
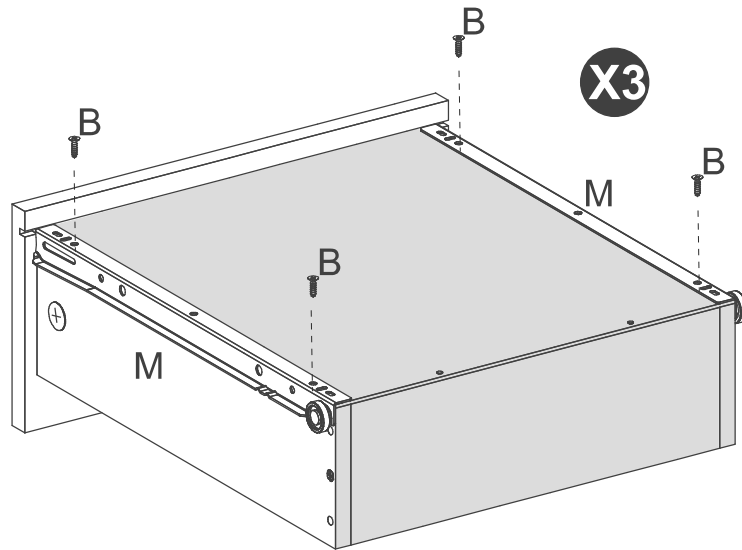
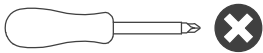

STEP 18

PARTS REQUIRED

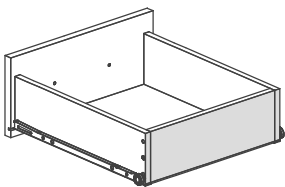

HARDWARE REQUIRED

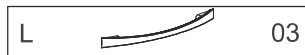
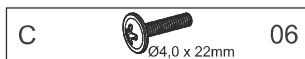

TOOLS REQUIRED

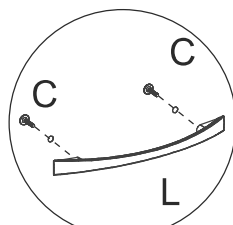
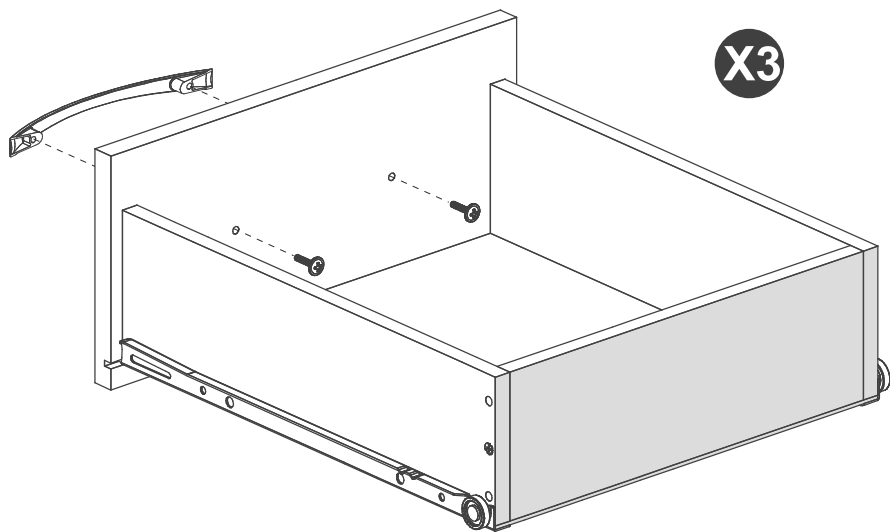
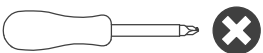

Detail 11

STEP 19

PARTS REQUIRED

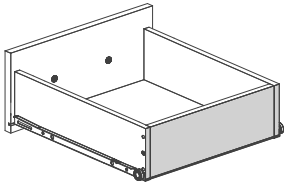

HARDWARE REQUIRED



TOOLS REQUIRED

X3

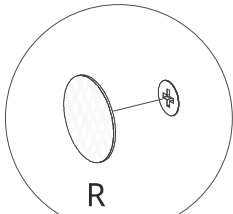
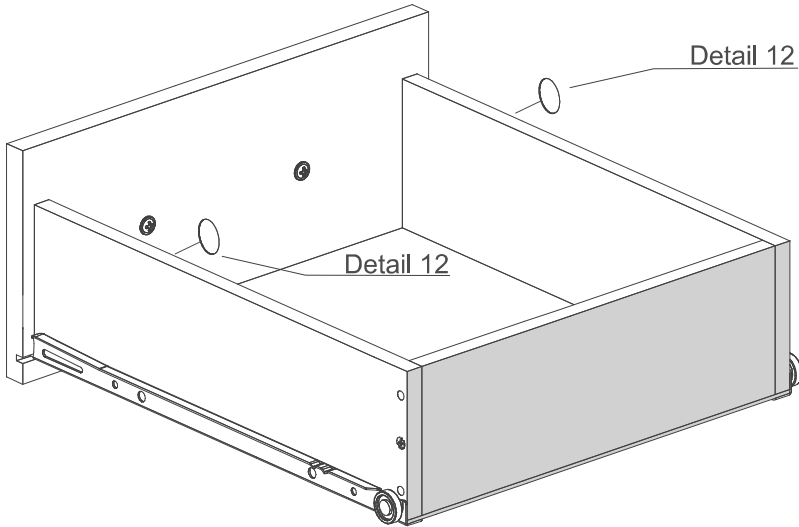

Detail 12

STEP 20

PARTS REQUIRED

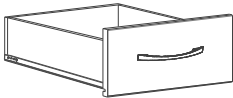

HARDWARE REQUIRED



TOOLS REQUIRED

See the last page

TIP
If desired, after assembly use an alcohol cleaner to erase the number printed on the parts.

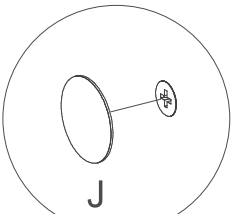
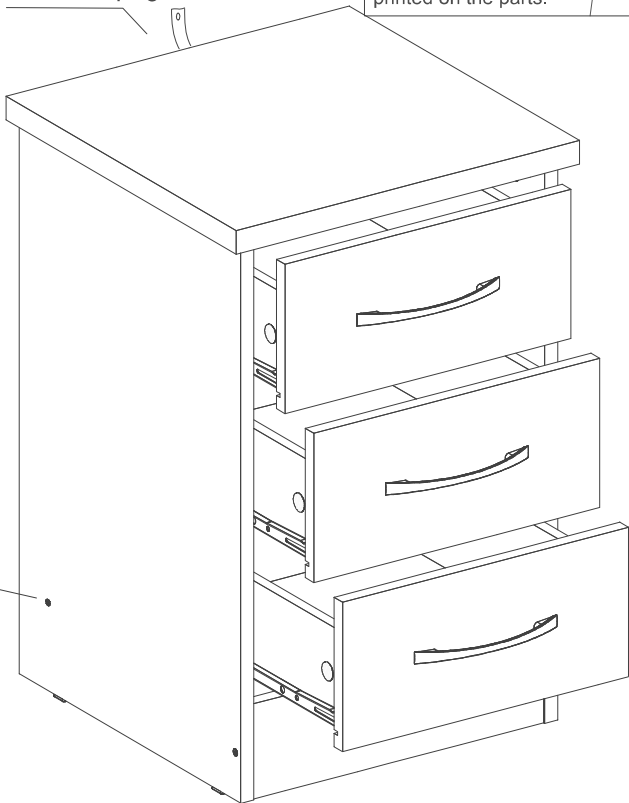

Detail 12

WARNING

Serious or fatal injuries can occur from furniture tipping over. To prevent the furniture from tipping over we recommend that it is permanently fixed to the wall.

Wall fixings are not supplied with this product as different wall materials require different types of fixing devices.

Please make sure you use fixings suitable for the walls in your home.

