

NEVADA 3 DOOR 2 DRAWER WARDROBE

ASSEMBLY INSTRUCTIONS

BLACK GLOSS

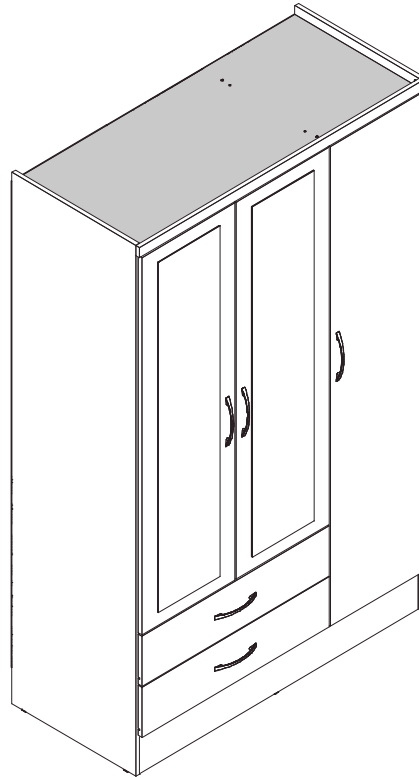

IMPORTANT

FOR DOMESTIC USE ONLY

PLEASE READ BEFORE YOU CONTINUE FURTHER

CARE AND MAINTENANCE

After unpacking this product please keep the original packaging in case it needs to be returned for any reason.

- Please ensure all fittings and parts are present before commencing with assembly.
- Never drag or push products as this could cause damage to the joints making it inferior.
- We strongly recommend that you keep children away from your work area.
- We recommend that you lay a blanket or sheet on the floor to avoid damage to both your floor and the product.
- Assemble this product as close to its final position as possible.
- Do not place this product next to a radiator or in direct sunlight.
- Do not drag or push items across your high gloss furniture as this may cause the surface to scratch
- Wood is a natural product and may expand if subjected to damp and may shrink or crack if subjected to heat. Therefore it is recommended that room temperature is maintained, with no sudden temperature fluctuations.
- Make sure any spillage is wiped off immediately.
- Do not place hot or chilled items directly on to the surface, use a place mat or marking will occur.
- For general cleaning use a soft cotton or micro fibre cloth, and do not use detergents of any kind.
- From time to time it may be necessary to tighten fittings, regular inspections should be carried out.
- Do not place on a wet or damp floor as staining may occur to your floor.

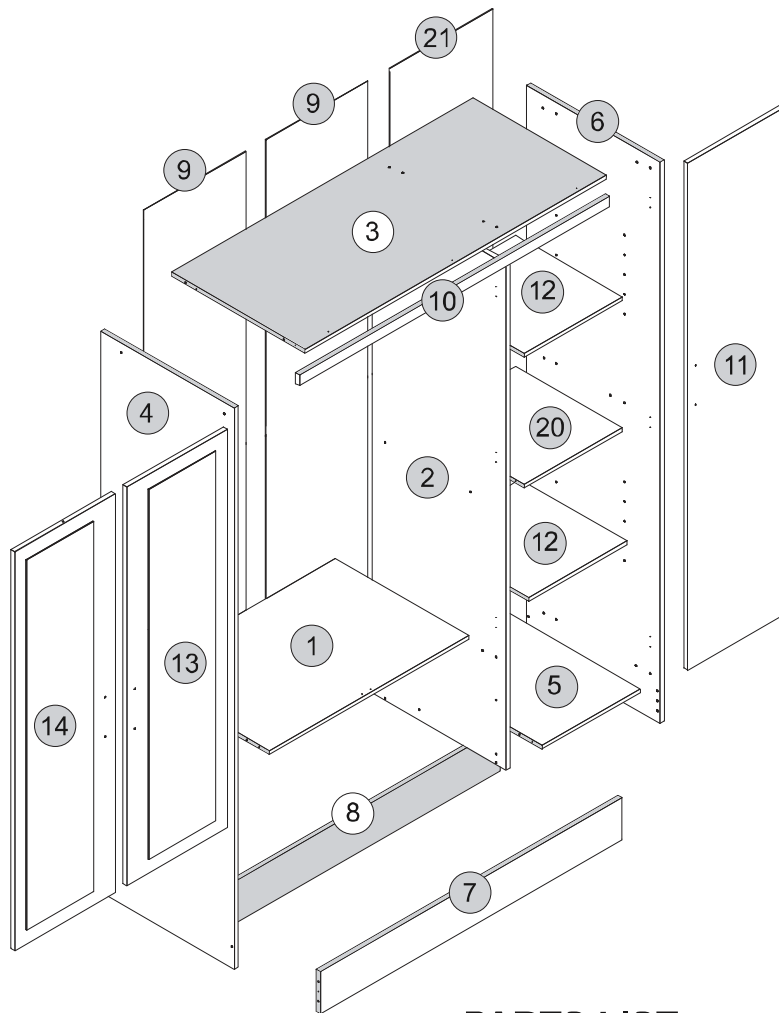

TOOLS REQUIRED

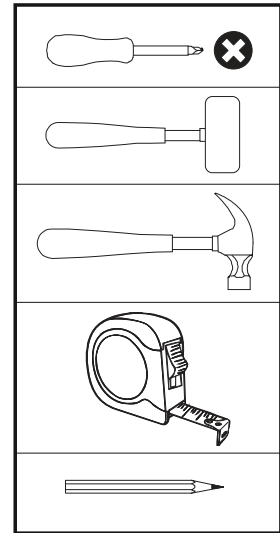

PARTS LIST











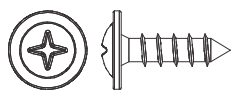

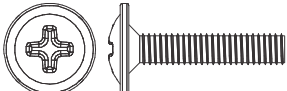
Please Note:

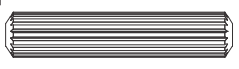
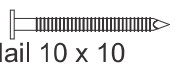
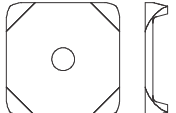
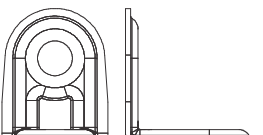
The below parts have all been stamped with the part number to help identify them during assembly.

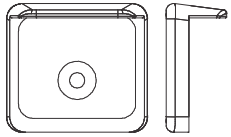
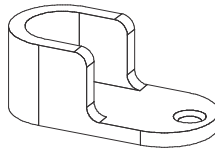
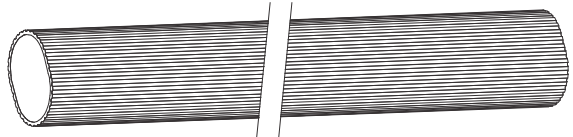
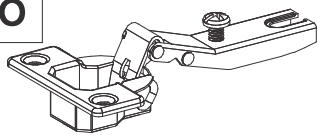
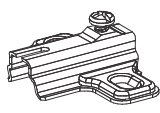
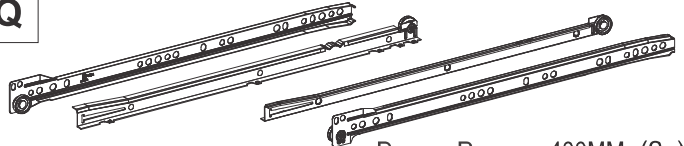
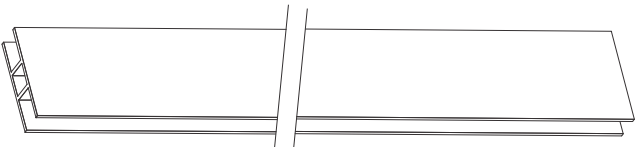
Part Number	Part Code	Part Description	Quantity	Carton
01	S100-101-182-HV1-01	Large Base Panel	1	2/3
02	S100-101-182-HV1-02	Division Panel	1	1/3
03	S100-101-182-HV1-03	Top Panel	1	2/3
04	S100-101-182-HV1-04	Left Side Panel	1	1/3
05	S100-101-182-HV1-05	Small Base Panel	1	2/3
06	S100-101-182-HV1-06	Right Side Panel	1	1/3
07	S100-101-182-HV1-07	Front Baseboard	1	2/3
08	S100-101-182-HV1-08	Back Baseboard	1	2/3
09	S100-101-182-HV1-09	Small Back Panel	2	3/3
10	S100-101-182-HV1-10	Frame	1	1/3
11	S100-101-182-HV1-11	Large Door	1	3/3
12	S100-101-182-HV1-12	Movable Shelf	2	2/3
13	S100-101-182-HV1-13	Right Small Door	1	3/3
14	S100-101-182-HV1-14	Left Small Door	1	3/3
15	S100-101-182-HV1-15	Drawer Side	4	2/3
16	S100-101-182-HV1-16	Drawer Back Panel	2	2/3
17	S100-101-182-HV1-17	Drawer Front	2	2/3
18	S100-101-182-HV1-18	Drawer Bottom	2	1/3
19	S100-101-182-HV1-19	Drawer Support Bar	2	2/3
20	S100-101-182-HV1-20	Shelf	1	2/3
21	S100-101-182-HV1-21	Large Back Panel	1	3/3

FITTINGS LIST

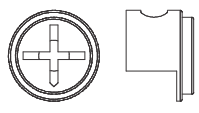
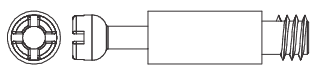
SEC/SH/09/21/HV1

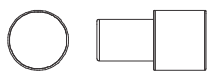
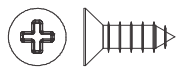
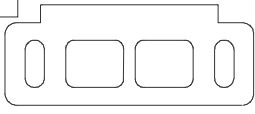
<p>A</p>  <p>Flat Head Screw Ø6,0 x 10mm (8x)</p> <p>1/+</p>	<p>B</p>  <p>Flan Head Screw Ø4,0 x 14mm (9x)</p> <p>1/+</p>	<p>C</p>  <p>Flat Head Screw Ø4,0 x 14mm (52x)</p> <p>2/+</p>	<p>D</p>  <p>Flan Head Screw Ø4,0 x 20mm (10x)</p> <p>2/+</p>
<p>E</p>  <p>Flat Head Screw Ø3,5 x 40mm (4x)</p> <p>1/+</p>	<p>F</p>  <p>Flat Head Screw Ø4,0 x 50mm (26x)</p> <p>2/+</p>	<p>G</p>  <p>2/+ Dowel Ø6,0 x 30mm (46x)</p>	
<p>H</p>  <p>Nail 10 x 10</p> <p>2/+ Nail 10x10 Ringed-1,5x23mm (88x)</p>	<p>I</p>  <p>2/+ Back Panel Bracket 14x14mm (16x)</p>	<p>J</p>  <p>1/+ 'L' Metallic Support 18x18MM (7x)</p>	<p>K</p>  <p>1/+ Washer Ø16x7 (4x)</p>
<p>L</p>  <p>1/+ Plastic Foot L 19x17x8mm Ø2 (6x)</p>	<p>M</p>  <p>Hanging Rail Support Plastic (2X)</p>	<p>N</p>  <p>Hanging Rail 737x30X16X0,60MM (1x)</p>	
<p>O</p>  <p>Hinge 26MM High Lap (9x)</p>	<p>P</p>  <p>Hinge Plate 26MM D5 (9x)</p>	<p>Q</p>  <p>Drawer Runners 400MM (2x)</p>	
<p>R</p>  <p>Back Panel Stri H 1633x19x3,8MM (1x)</p>	<p>S</p>  <p>Strap 200x20x1MM (2x)</p>	<p>T</p>  <p>Handle (5x)</p>	
<p>U</p>  <p>2/+ Hole Plugs 19MM (26x)</p>	<p>V</p>  <p>Glue 10Gr (2x)</p>	<p>W</p>  <p>1/+ Cam Nut Ø12x8,8MM (4x)</p>	<p>X</p>  <p>1/+ Cam Bolt (4x)</p>
<p>Y</p>  <p>Flan Head Screw Ø3,5 x 30mm (2x)</p> <p>1/+</p>	<p>Z</p>  <p>1/+ Support Pin 7x6mm (8x)</p>	<p>A1</p>  <p>Flat Head Screw Ø4,0 x 12mm (18x)</p> <p>2/+</p>	<p>B1</p>  <p>Door Support L42xP27xA28MM (2x)</p>

TIPS FOR FITTINGS CAM-LOCKS

WHEN FITTING CAM NUT. ENSURE STARTING POSITION IS CORRECT BEFORE YOU INSERT CONNECTING CAM BOLT TURN CLOCKWISE UNTIL SECURE



↑
CORRECT



WRONG

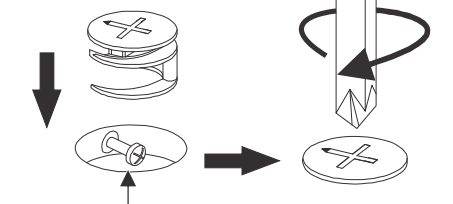

Cam bolt head needs to be in centre

C1



+2 Hole Plugs Líneo 19mm (4x)

CAMBOLT

Tighten until shoulder is flush with panel. Do not overtighten or undertighten (see example beside)

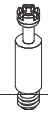

Shoulder

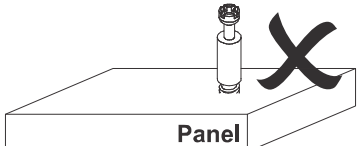

Panel

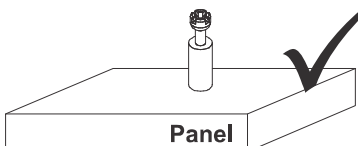

Panel

STEP 1

PARTS REQUIRED

2 - DIVISION PANEL x1

HARDWARE REQUIRED

G  02
Ø6,0 x 30mm

V  01
Glue

Z  04

TOOLS REQUIRED

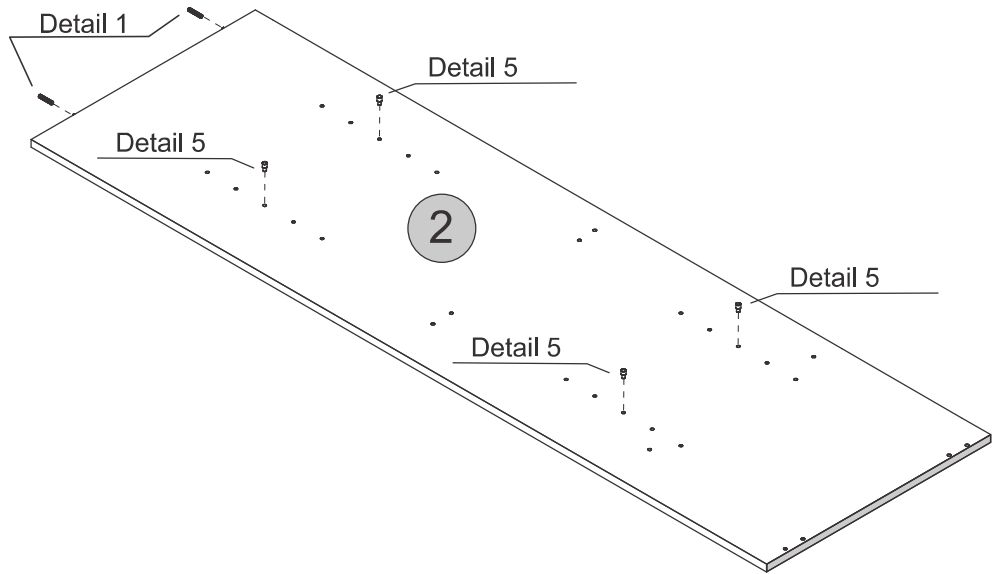
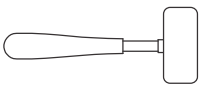

Detail 1

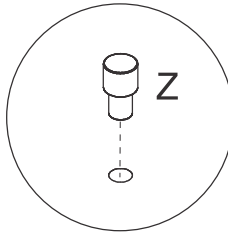

Detail 5

STEP 2

PARTS REQUIRED

2 - DIVISION PANEL x1

HARDWARE REQUIRED

C  08
Ø4,0 x 14mm

M  01

P  03

TOOLS REQUIRED

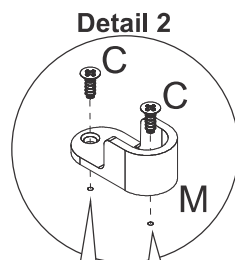
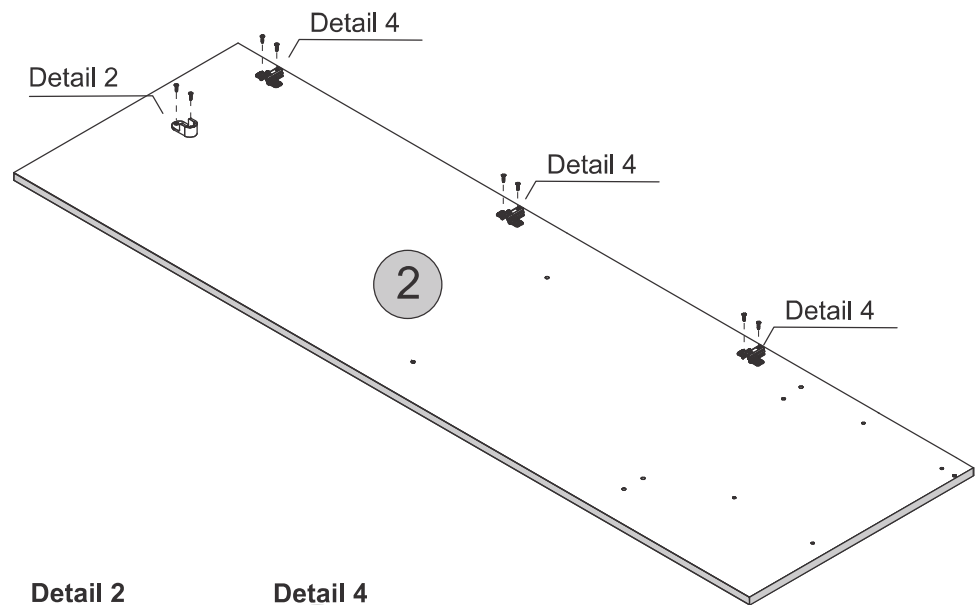
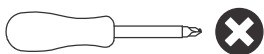

Please note:
Pre-marked
Holes

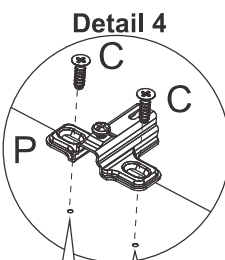

Please note:
Pre-marked
Holes

STEP 3

PARTS REQUIRED

2 - DIVISION PANEL x1

HARDWARE REQUIRED

A  04
Ø6,0 x 10mm

Q  02
Right

TOOLS REQUIRED

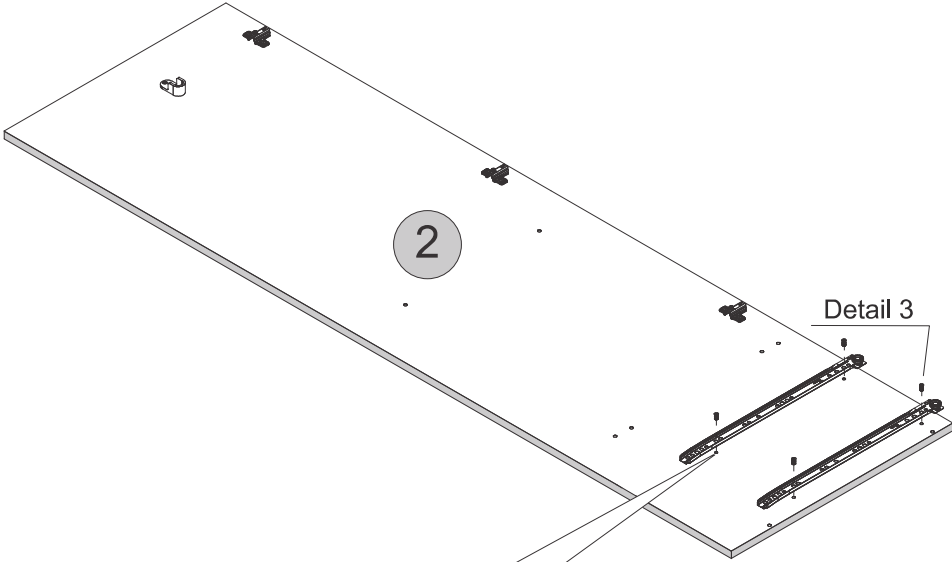
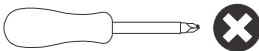

PLEASE NOTE
PRE-DRILLED
HOLES.

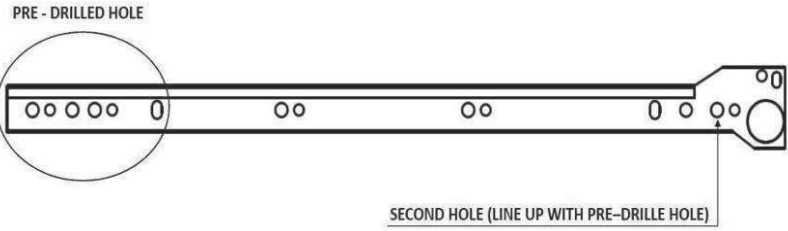

Detail 3

STEP 4

PARTS REQUIRED

4 - LEFT SIDE PANEL x1

HARDWARE REQUIRED

C  08
Ø4,0 x 14mm

M  01

P  03

TOOLS REQUIRED

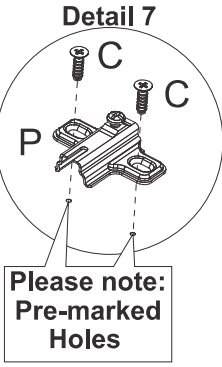
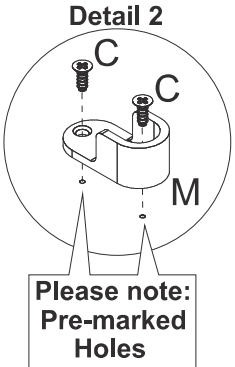
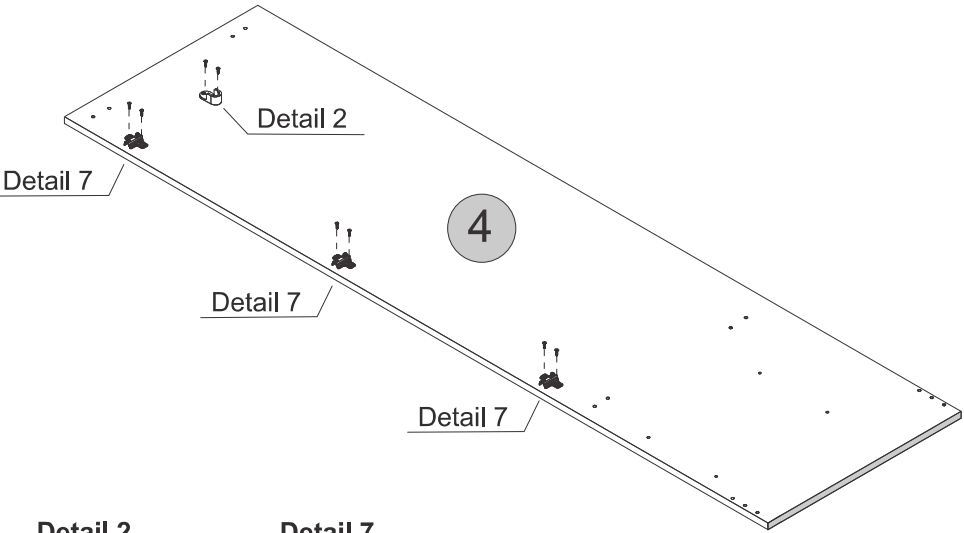

STEP 5

PARTS REQUIRED

4 - LEFT SIDE PANEL x1

HARDWARE REQUIRED

A  04
Ø6,0 x 10mm

H  02

L  02

Q  02

TOOLS REQUIRED

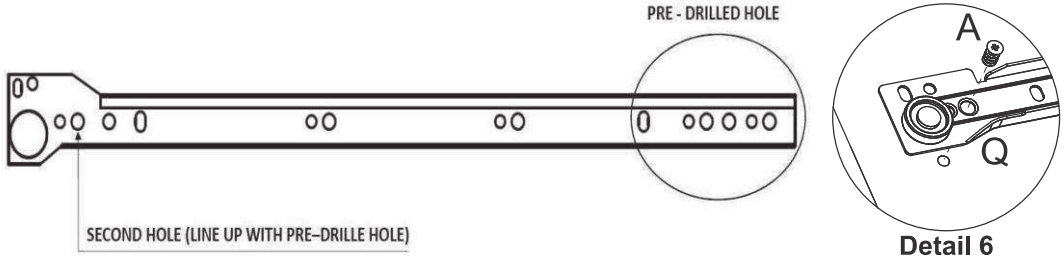
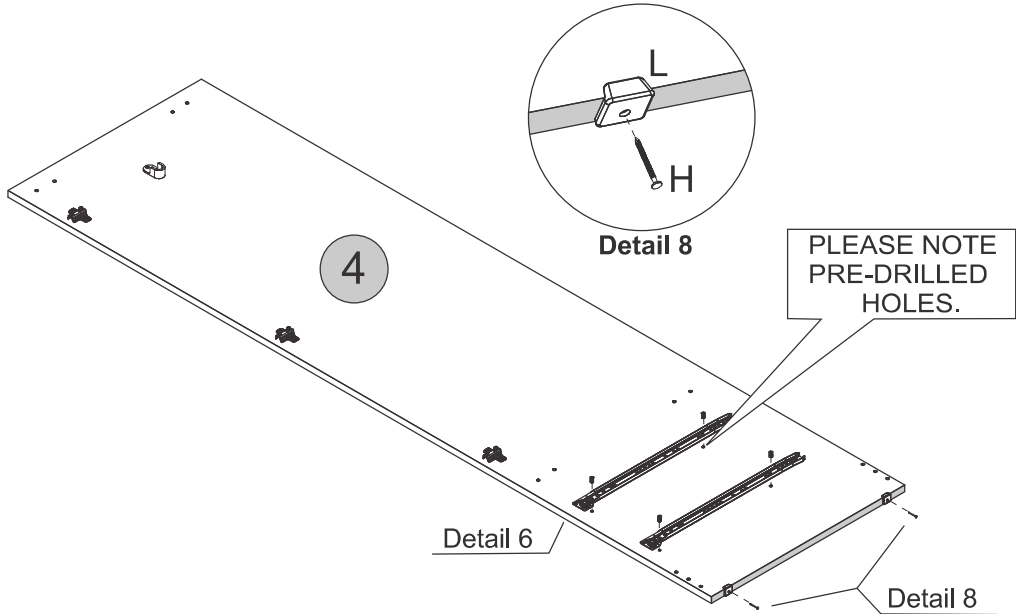
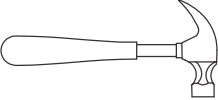
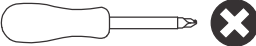

STEP 6

PARTS REQUIRED

6 - RIGHT SIDE PANEL x1

HARDWARE REQUIRED

C  06
Ø4,0 x 14mm

P  03

Z  04

TOOLS REQUIRED

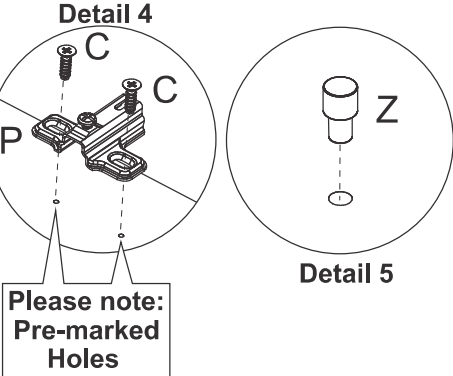
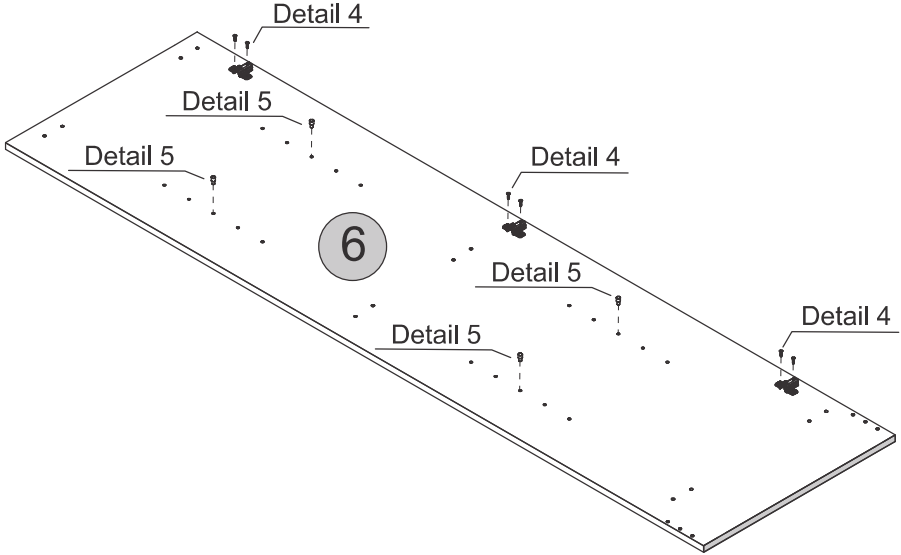
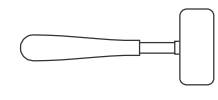
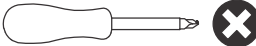





STEP 7

PARTS REQUIRED

- 6 - RIGHT SIDE PANEL x1
- 7 - FRONT BASEBOARD x1
- 8 - BACK BASEBOARD x1

HARDWARE REQUIRED

- G  08
Ø6,0 x 30mm
- H  04
- L  04
- V  01

TOOLS REQUIRED

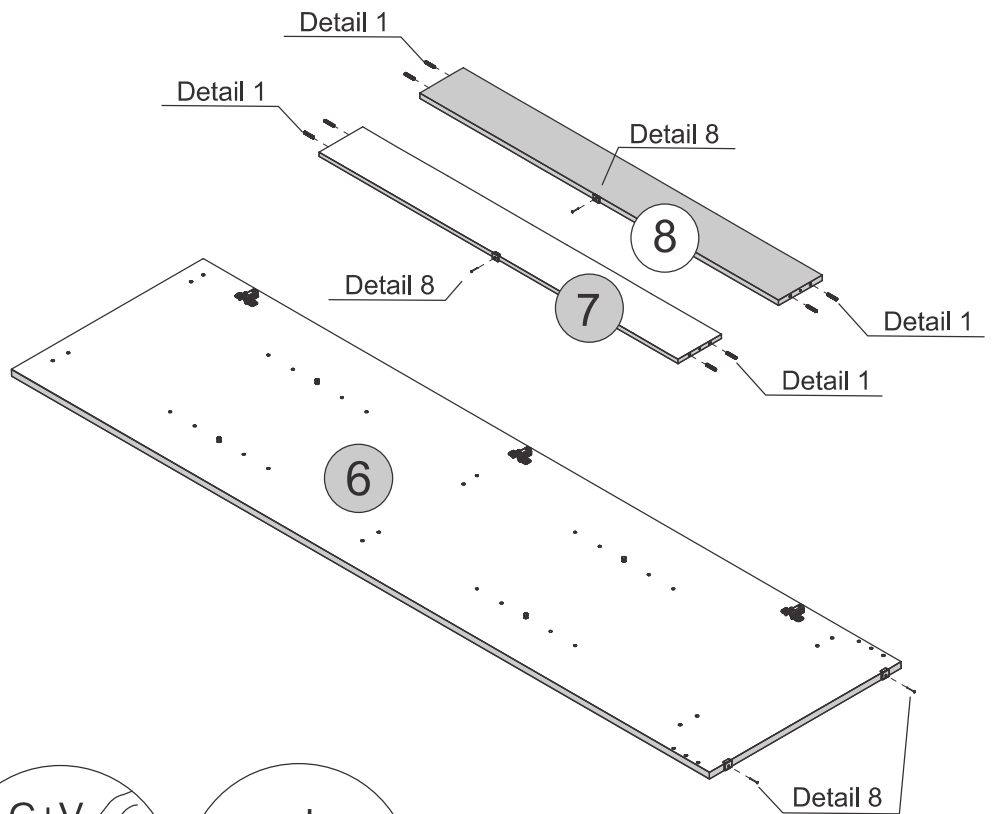
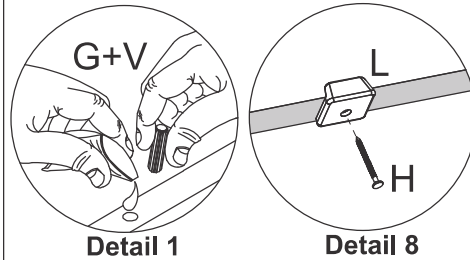
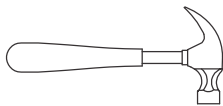



STEP 8

PARTS REQUIRED

- 1 - LARGE BASE PANEL x1
- 3 - TOP PANEL x1
- 5 - SMALL BASE PANEL x1
- 20 - SHELF x1

HARDWARE REQUIRED

- G  16
Ø6,0 x 30mm
- V  01

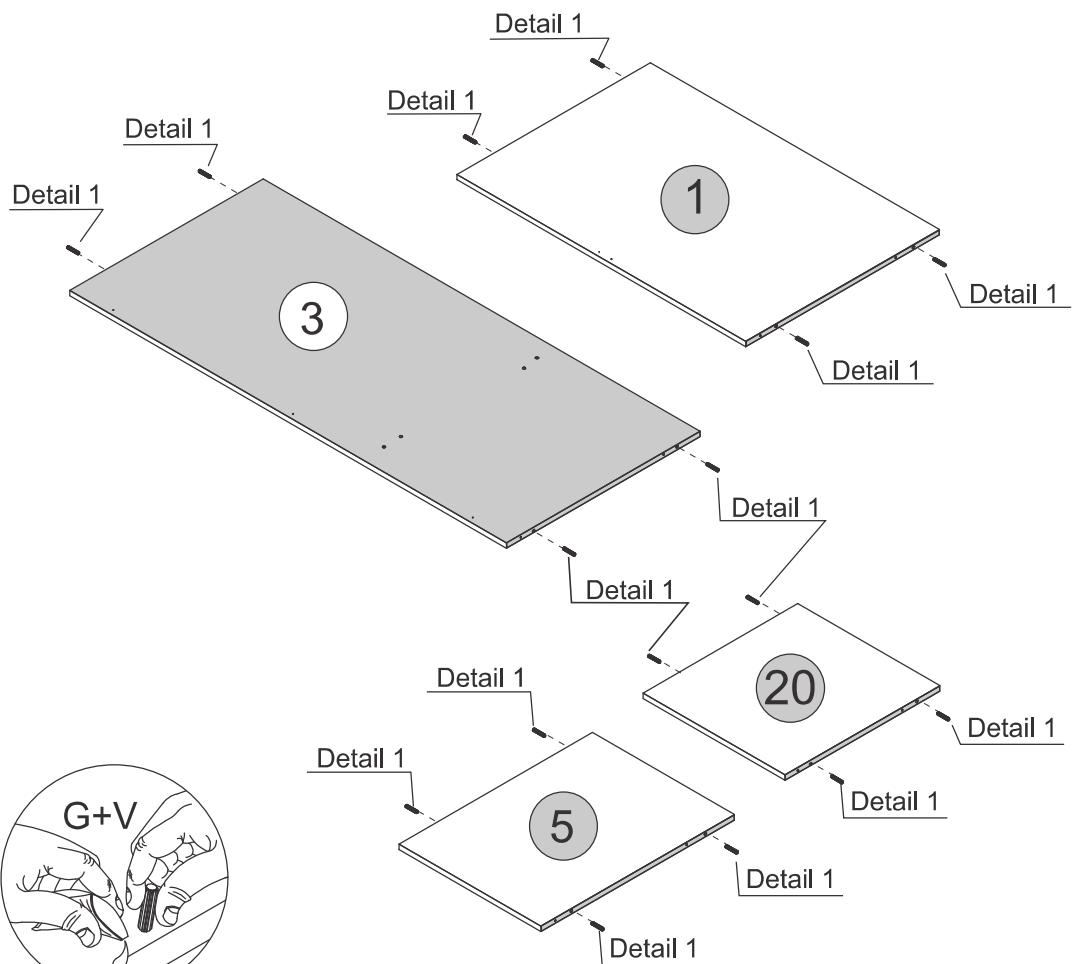
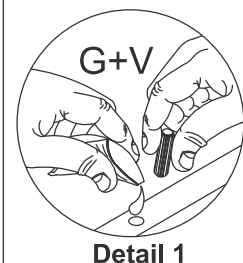

STEP 9

PARTS REQUIRED

1 - LARGE BASE PANEL x1

3 - TOP PANEL x1

HARDWARE REQUIRED

A1  07
Ø4,0 x 12mm

B1  02

J  03

TOOLS REQUIRED

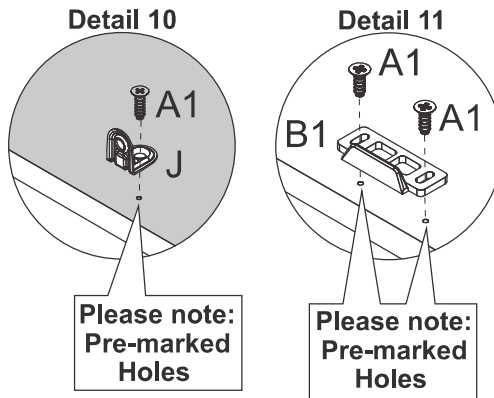
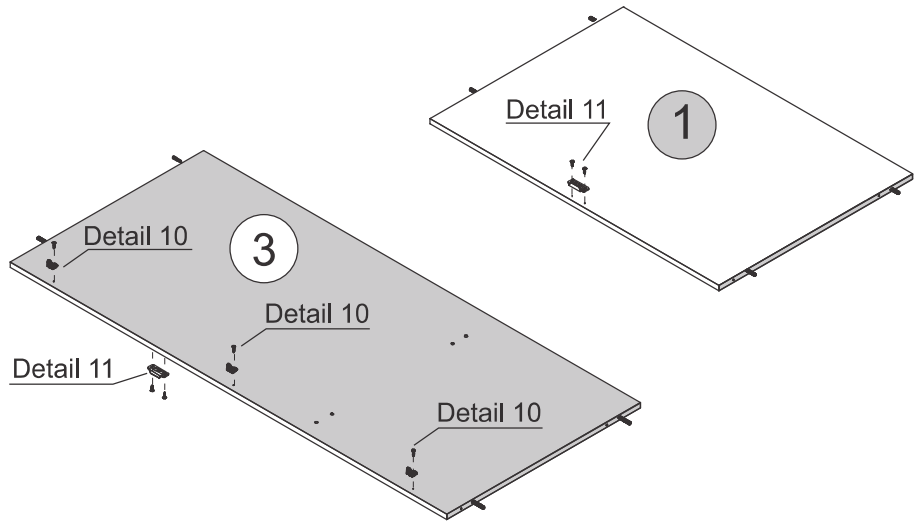
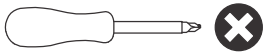

STEP 10

PARTS REQUIRED

1 - LARGE BASE PANEL x1

2 - DIVISION PANEL x1

3 - TOP PANEL x1

5 - SMALL BASE PANEL x1

HARDWARE REQUIRED

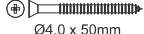
F  06
Ø4,0 x 50mm

V  01

TOOLS REQUIRED

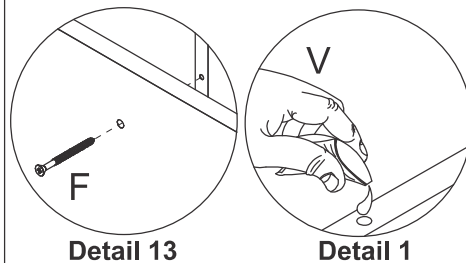
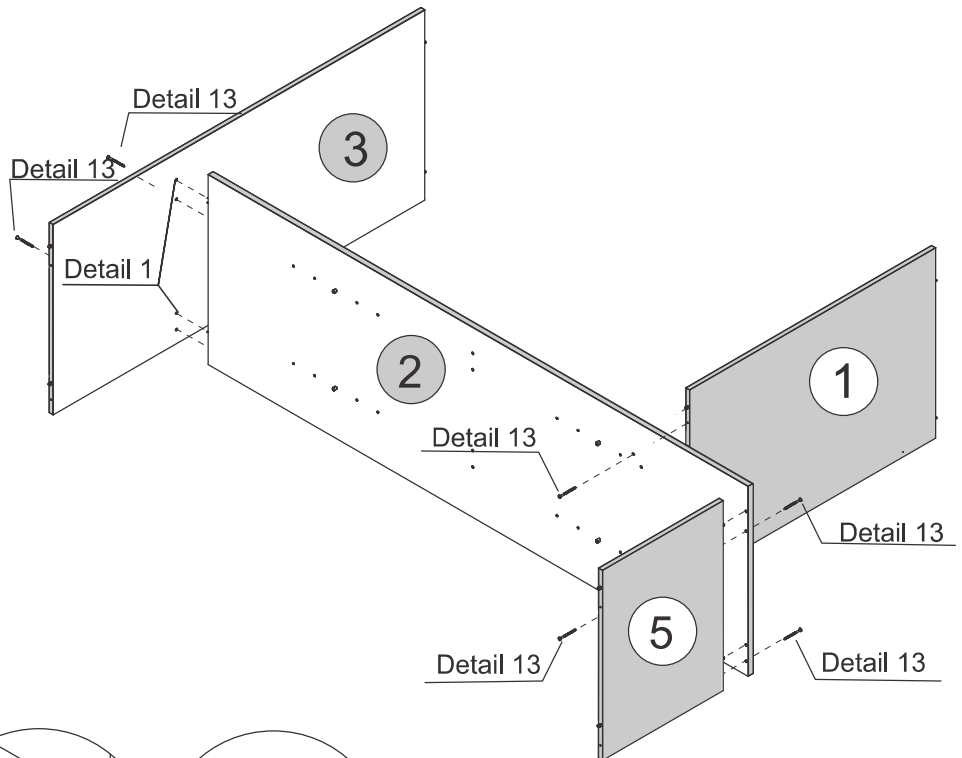
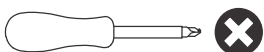

STEP 11

PARTS REQUIRED

4 - LEFT SIDE PANEL x1

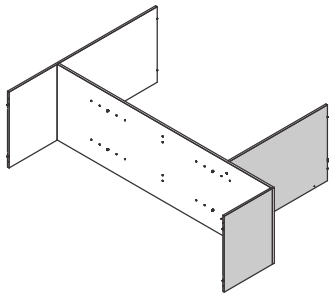

HARDWARE REQUIRED

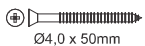
F  04
Ø4,0 x 50mm

V  01
Glue

TOOLS REQUIRED

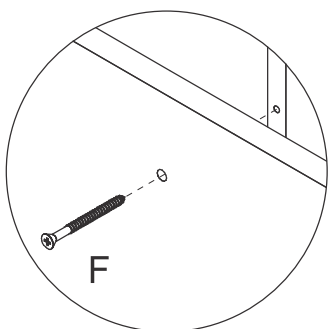
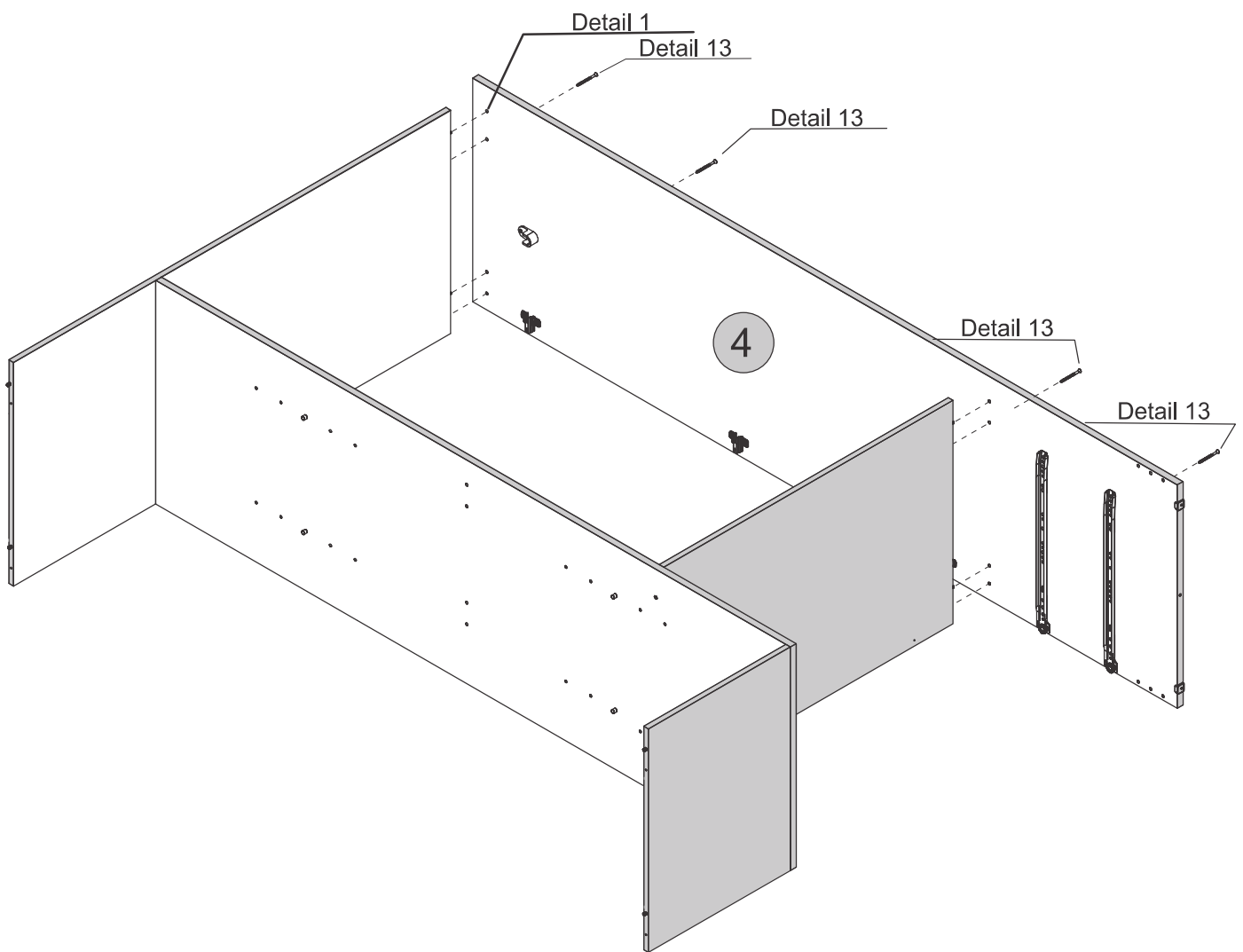
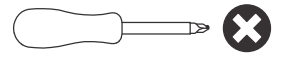

Detail 13

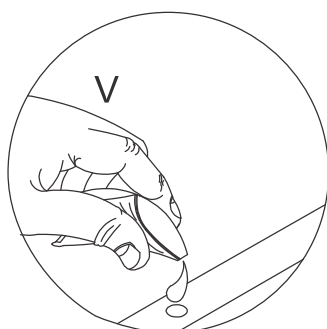

Detail 1

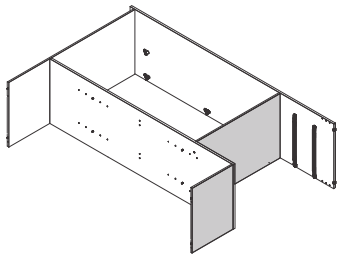

STEP 12

PARTS REQUIRED



6 - RIGHT SIDE PANEL	x1
7 - FRONT BASEBOARD	x1
8 - BACK BASEBOARD	x1
20 - SHELF	x1

HARDWARE REQUIRED

F	 $\text{Ø}4.0 \times 50\text{mm}$	12
V		01

TOOLS REQUIRED

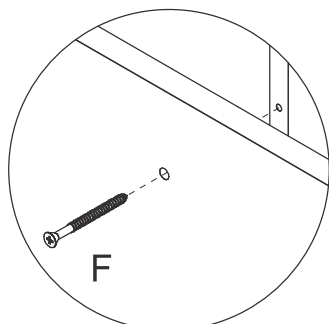
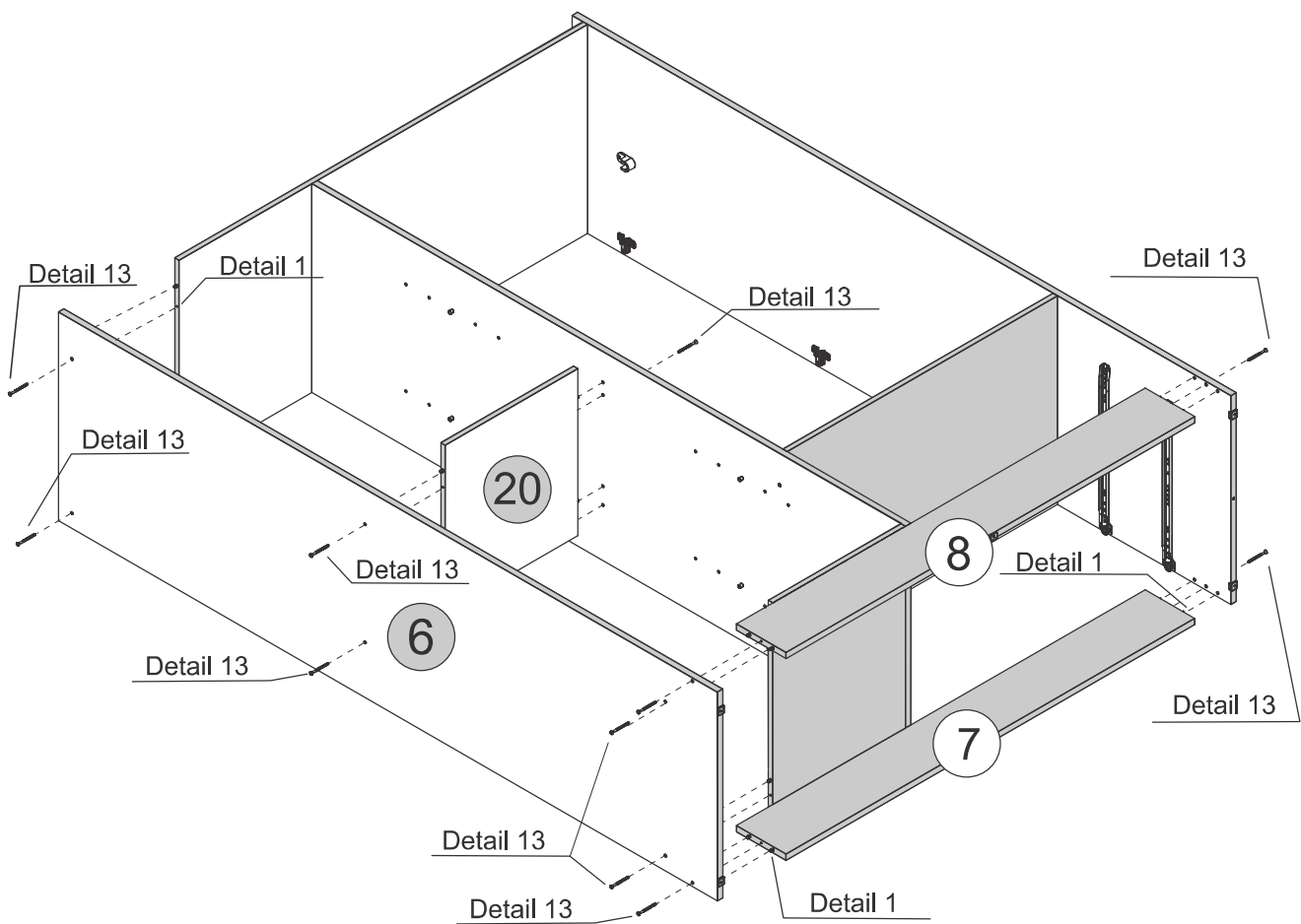
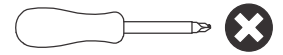

Detail 13

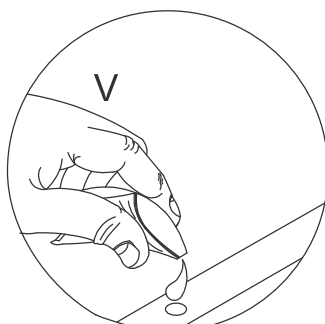

Detail 1

STEP 13

PARTS REQUIRED

9 - SMALL BACK PANEL x2

21 - LARGE BACK PANEL x1

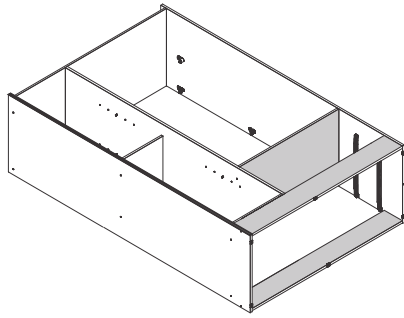

HARDWARE REQUIRED

H  10 x 10 59

I  16

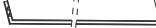
R  01

TOOLS REQUIRED

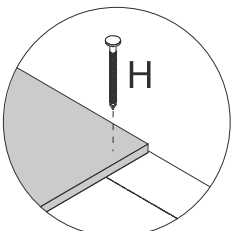
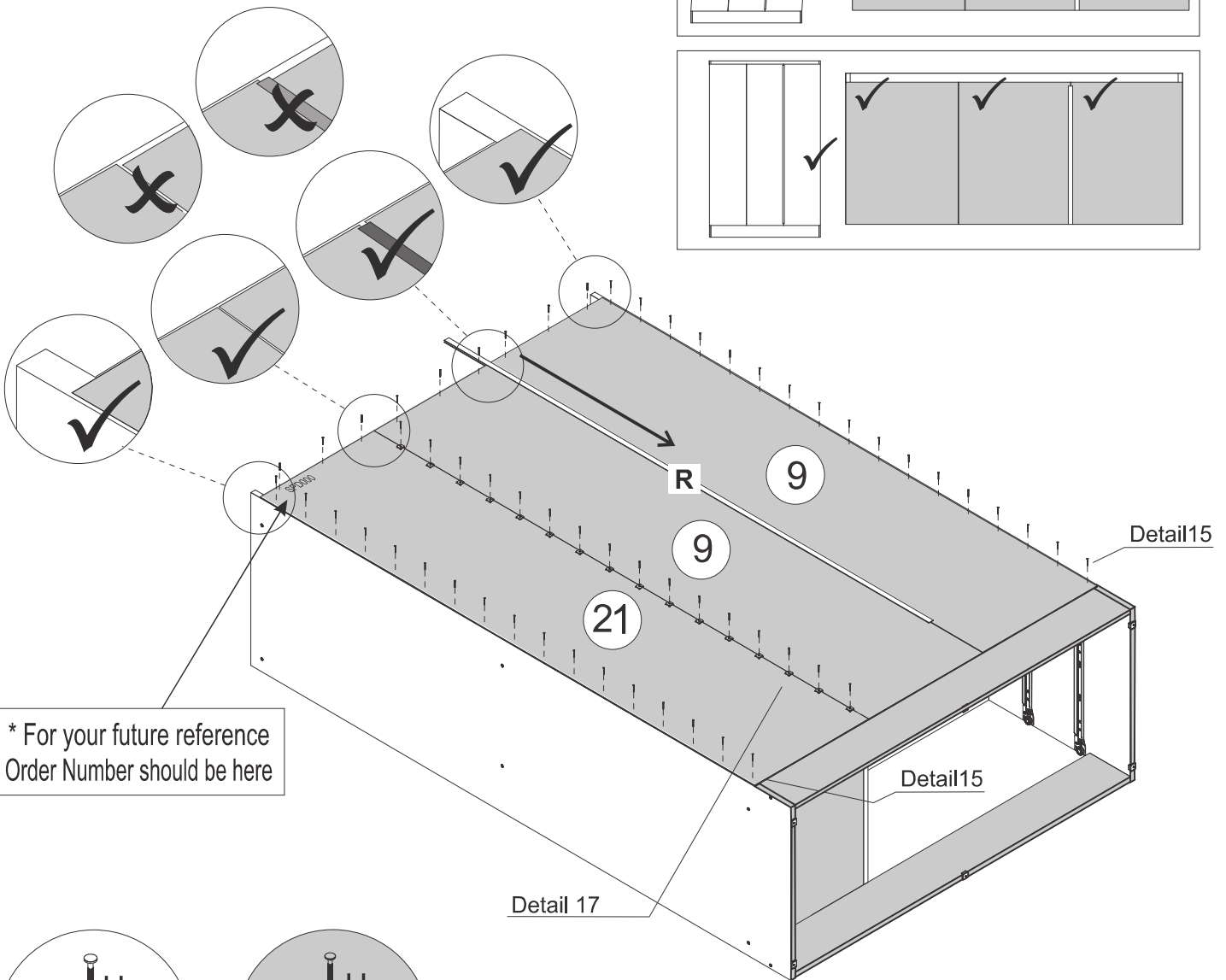
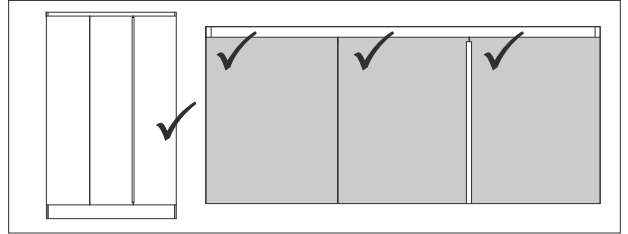
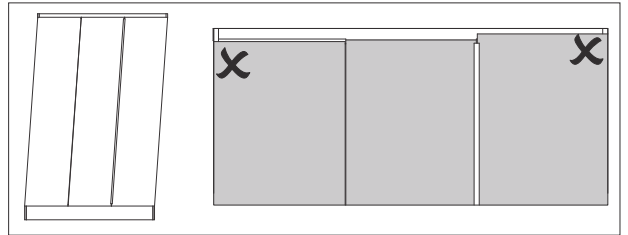
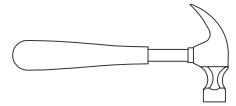

Detail 15

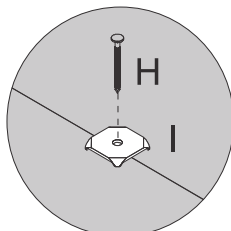

Detail 17

PARTS REQUIRED

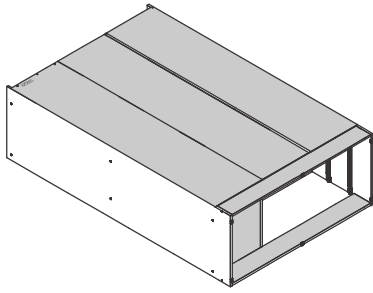

HARDWARE REQUIRED

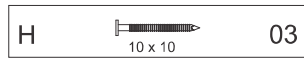

TOOLS REQUIRED

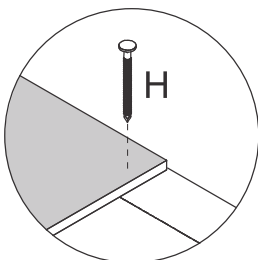
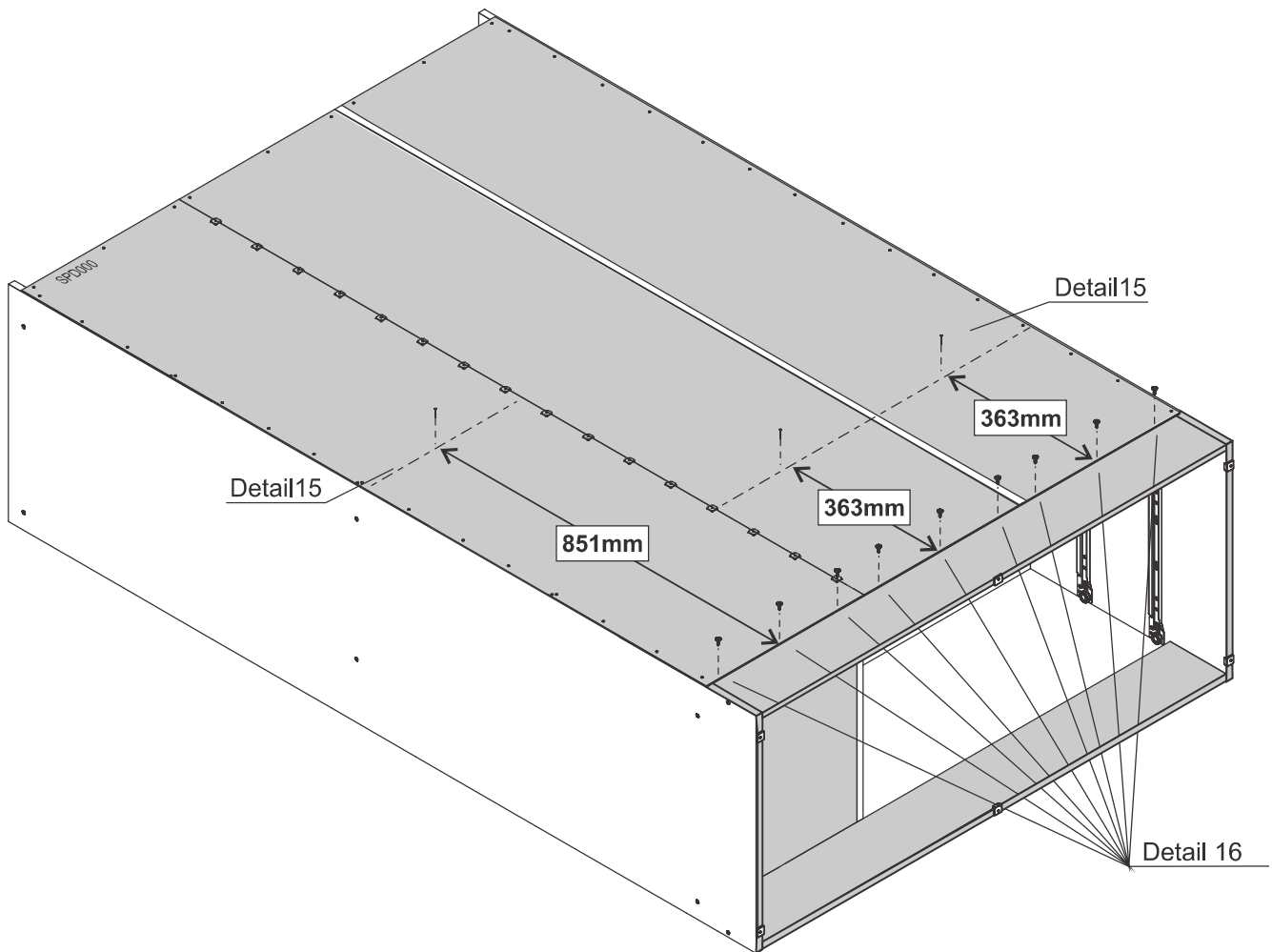
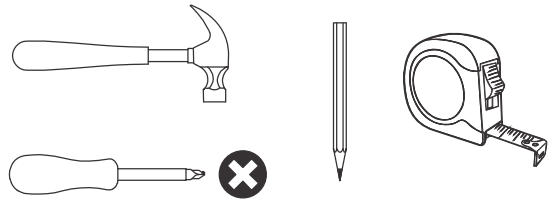

Detail 15

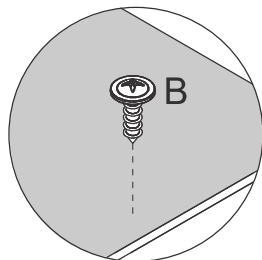

Detail 16

STEP 15

PARTS REQUIRED

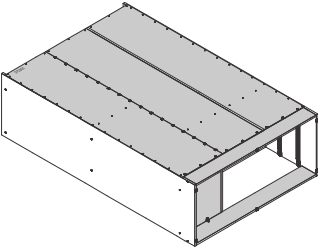

HARDWARE REQUIRED

A1  04
Ø4,0 x 12mm

J  02

TOOLS REQUIRED

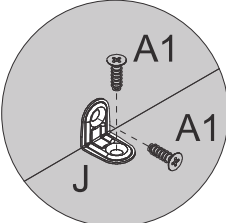
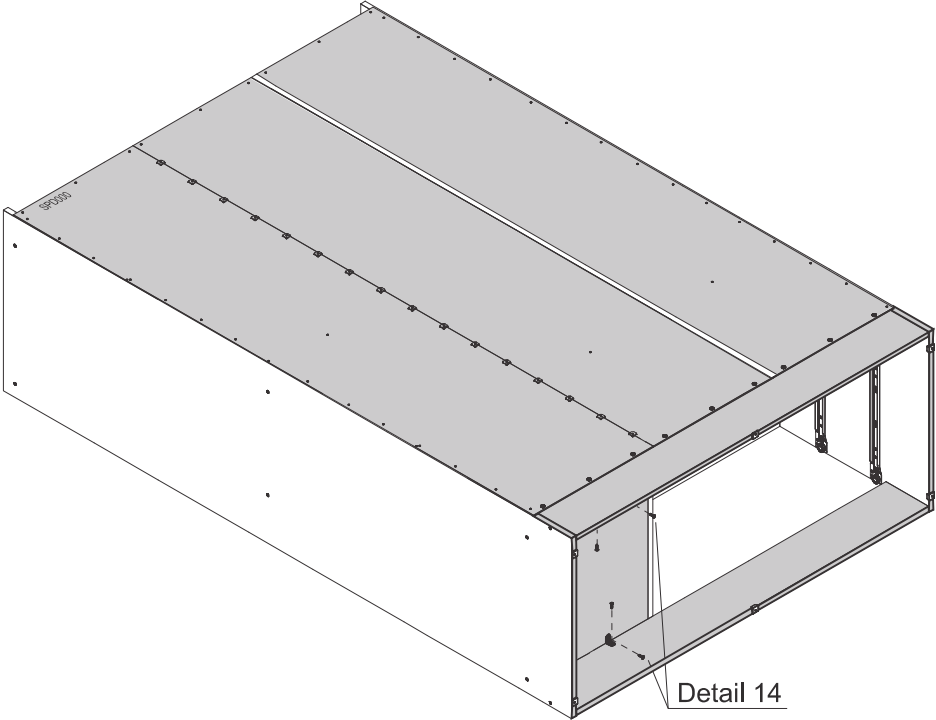
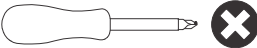

Detail 14

STEP 16

PARTS REQUIRED

10 - FRAME x1

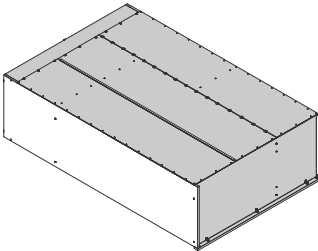

HARDWARE REQUIRED

J  02

A1  07
Ø4,0 x 12mm

TOOLS REQUIRED

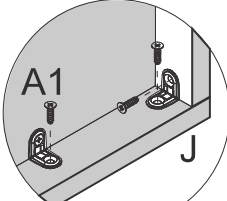
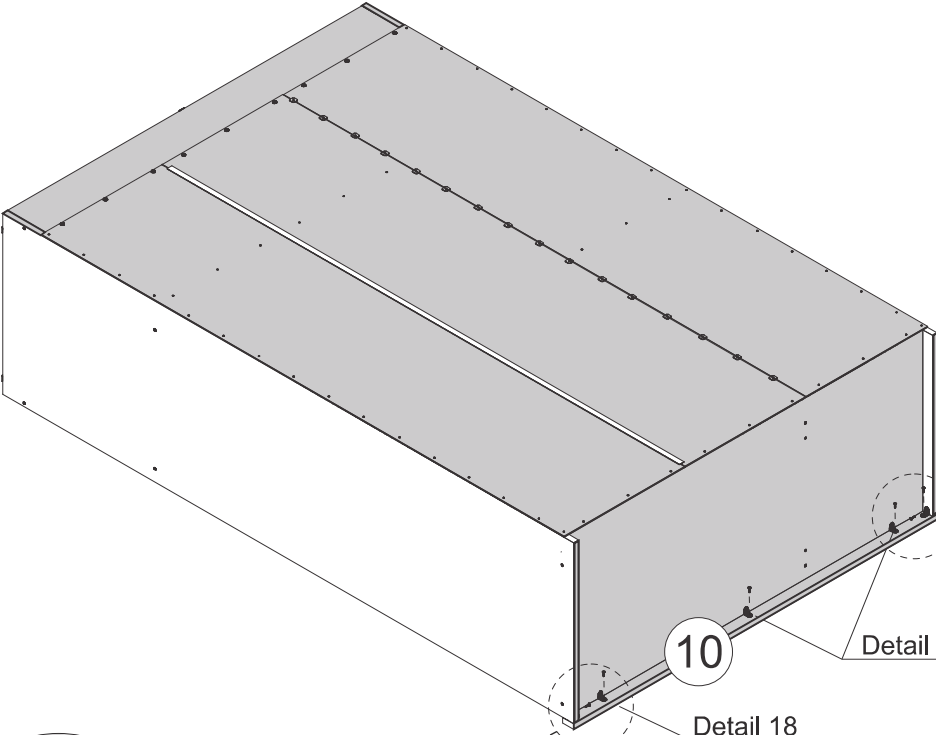

Detail 18

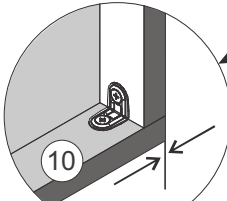

Align corners

STEP 17

PARTS REQUIRED

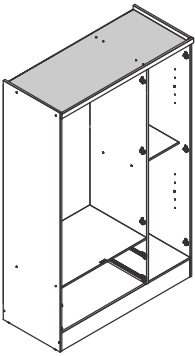

HARDWARE REQUIRED

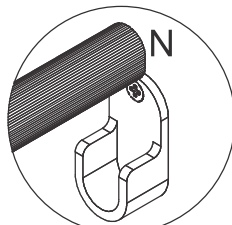
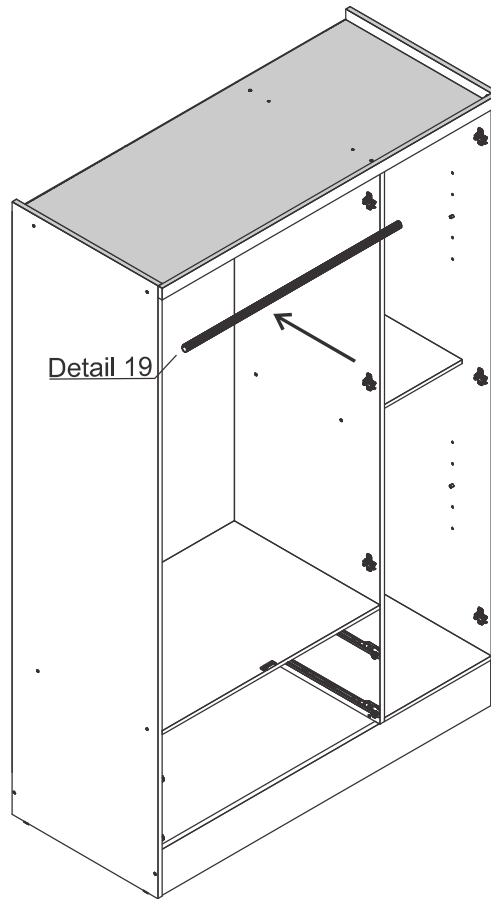

Detail 19

STEP 18

PARTS REQUIRED

15 - DRAWER SIDE	x4
------------------	----

16 - DRAWER BACK PANEL	x2
------------------------	----

19 - DRAWER BOTTOM SUPPORT BAR	x2
--------------------------------	----

HARDWARE REQUIRED

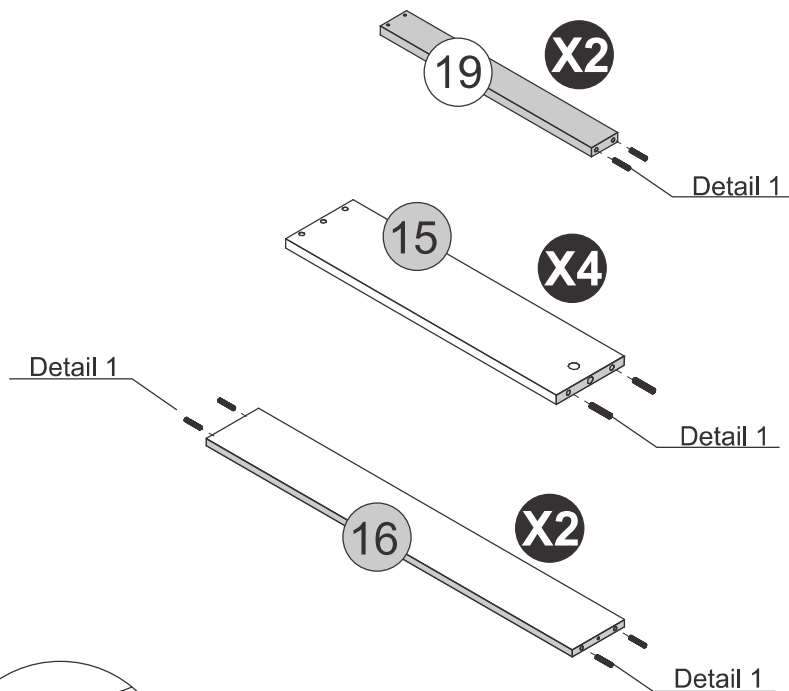
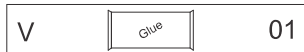
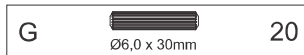

Detail 1

STEP 19

PARTS REQUIRED

17 - DRAWER FRONT x2

HARDWARE REQUIRED

X  04

TOOLS REQUIRED

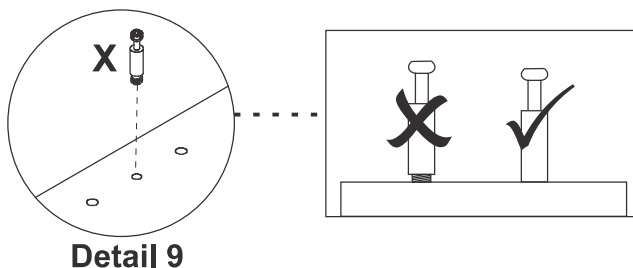
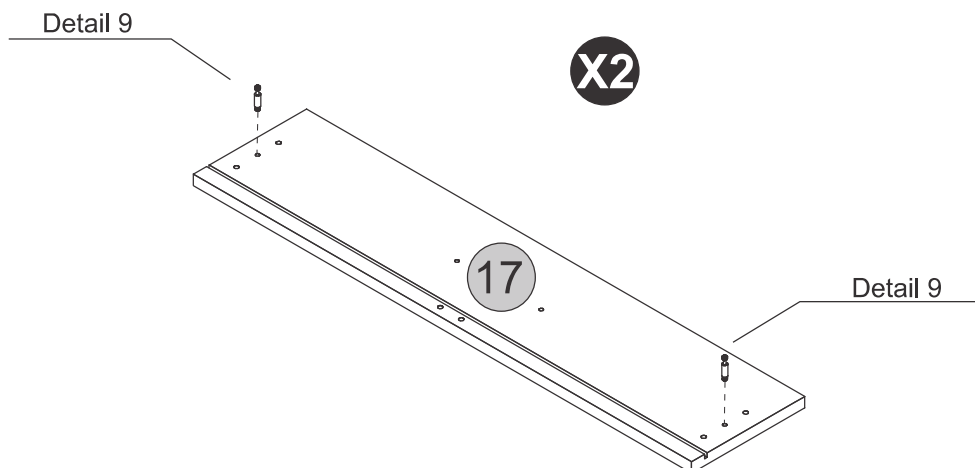
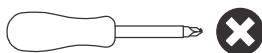

STEP 20

PARTS REQUIRED

15 - DRAWER SIDE x4

16 - DRAWER BACK PANEL x2

HARDWARE REQUIRED

F  04
Ø4,0 x 50mm

TOOLS REQUIRED

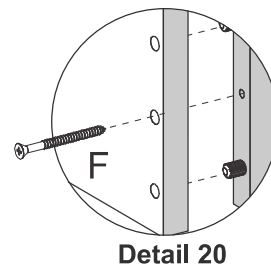
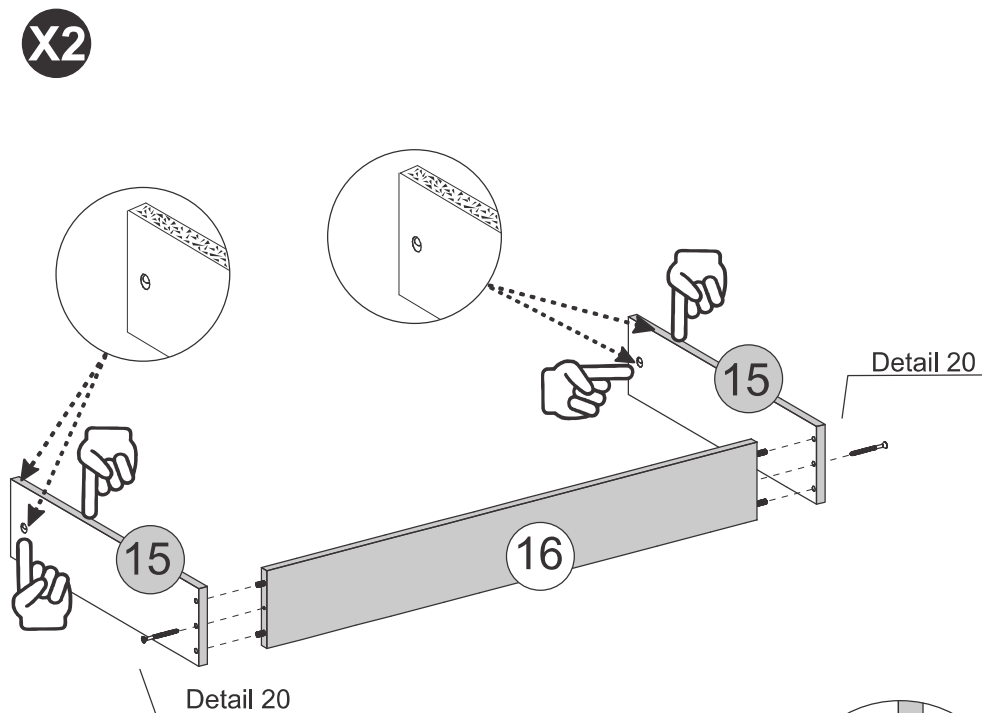

STEP 21

PARTS REQUIRED

17 - DRAWER FRONT x2

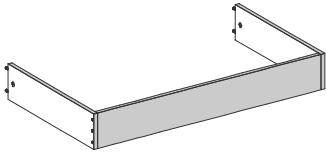

HARDWARE REQUIRED

C1  04

V  01

W  04

TOOLS REQUIRED

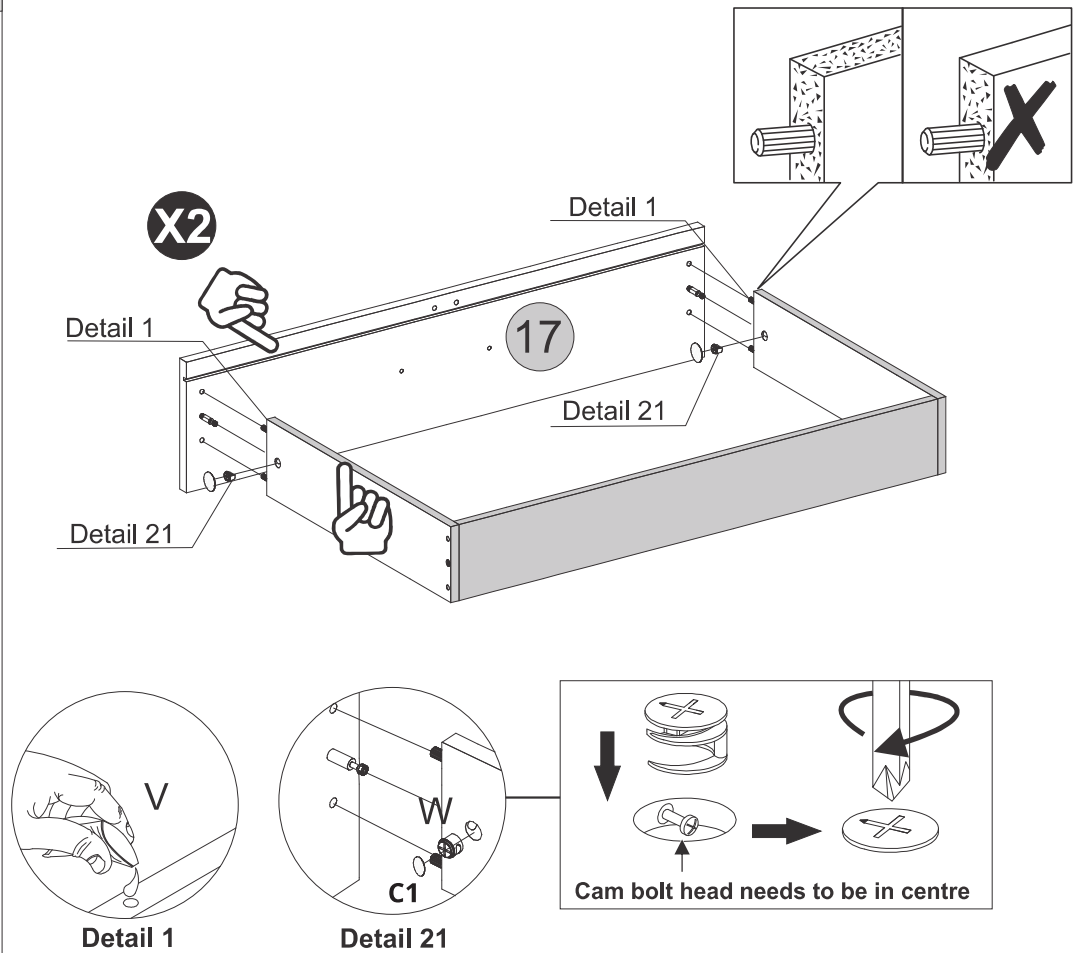
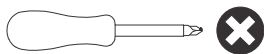

STEP 22

PARTS REQUIRED

18 - DRAWER BOTTOM x2

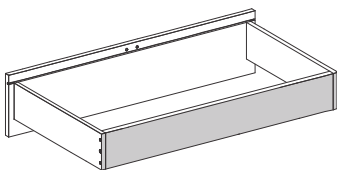

HARDWARE REQUIRED

H  10 x 10 08

TOOLS REQUIRED

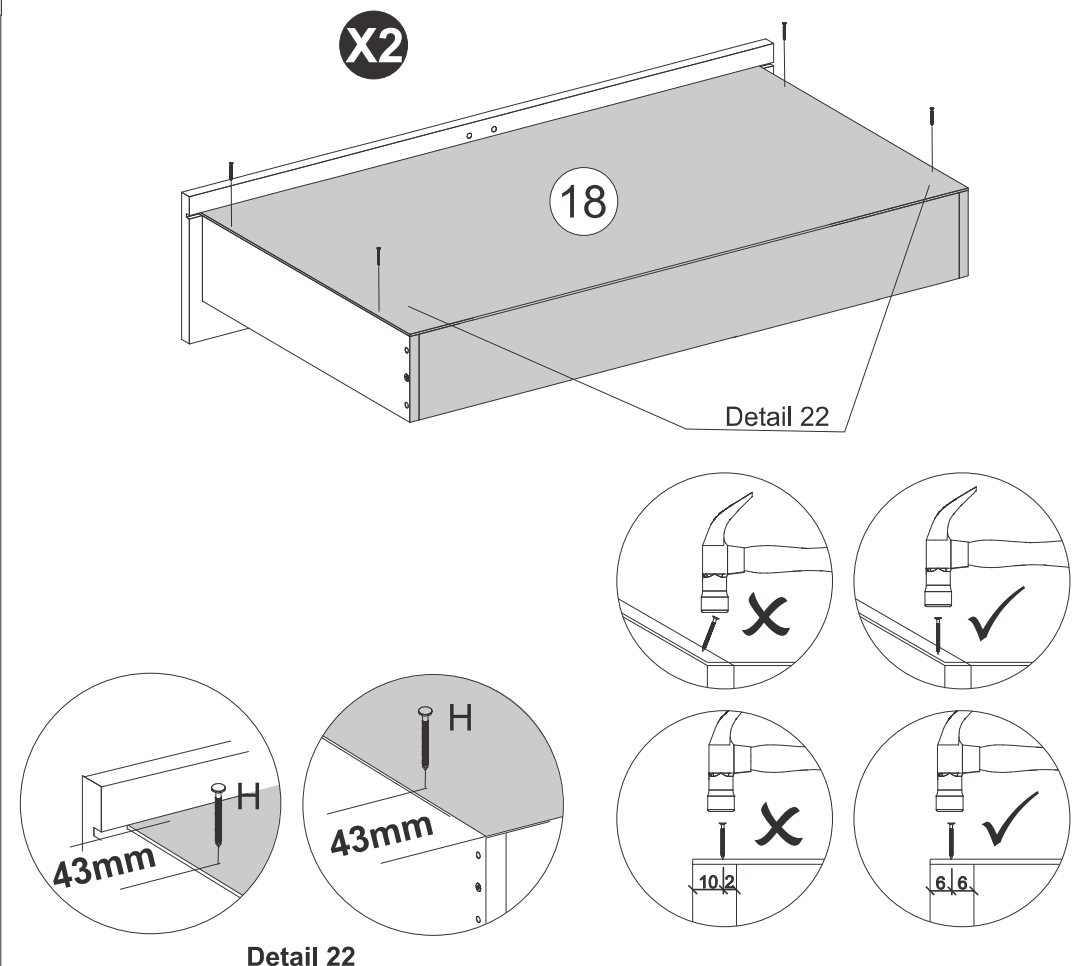
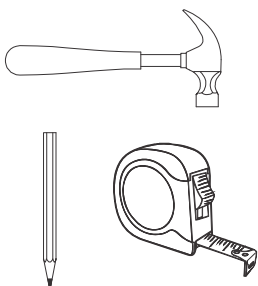

STEP 23

PARTS REQUIRED

19 - DRAWER BOTTOM SUPPORT BAR X2

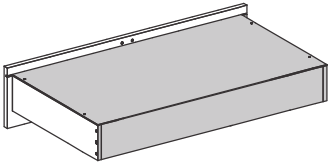

HARDWARE REQUIRED

H  12
10 x 10

V  01
Glue

TOOLS REQUIRED

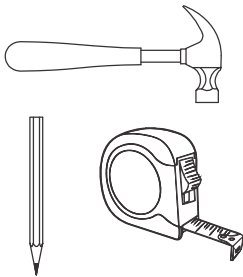

X2

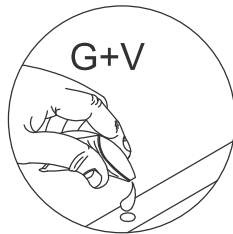
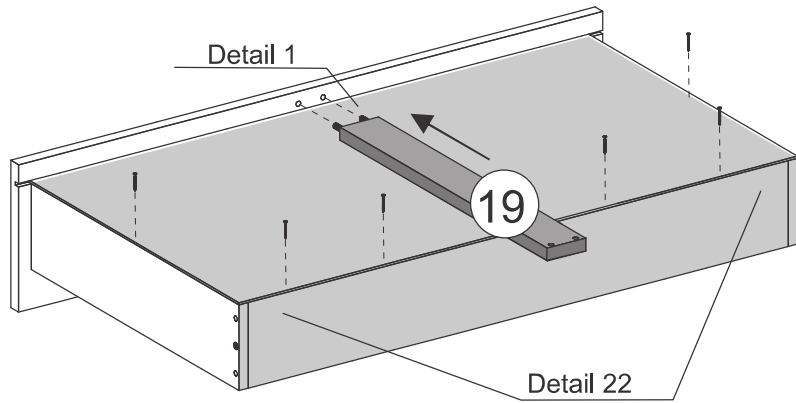

Detail 1

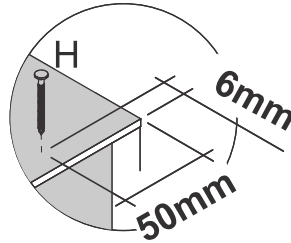

Detail 22

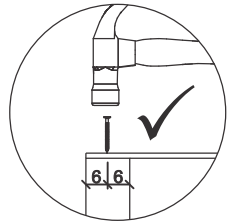
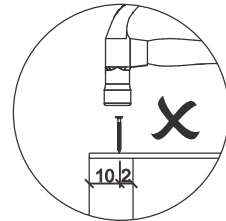
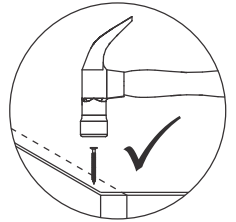
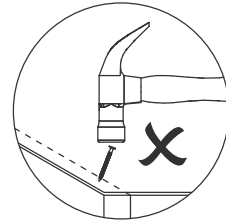

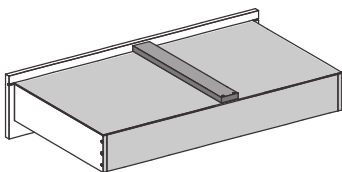

STEP 24

PARTS REQUIRED



HARDWARE REQUIRED

C  08
Ø4,0 x 14mm

E  04
Ø3,5 x 40mm

Q  02
LEFT

Q  02
RIGHT

TOOLS REQUIRED



X2

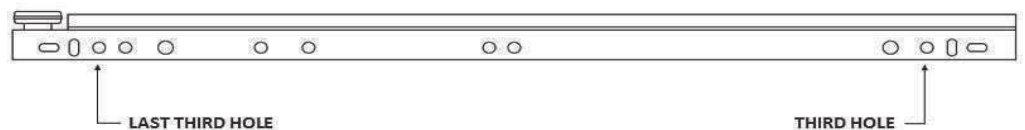
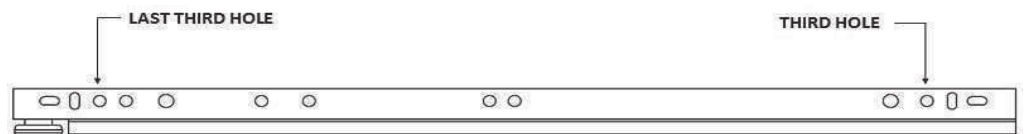
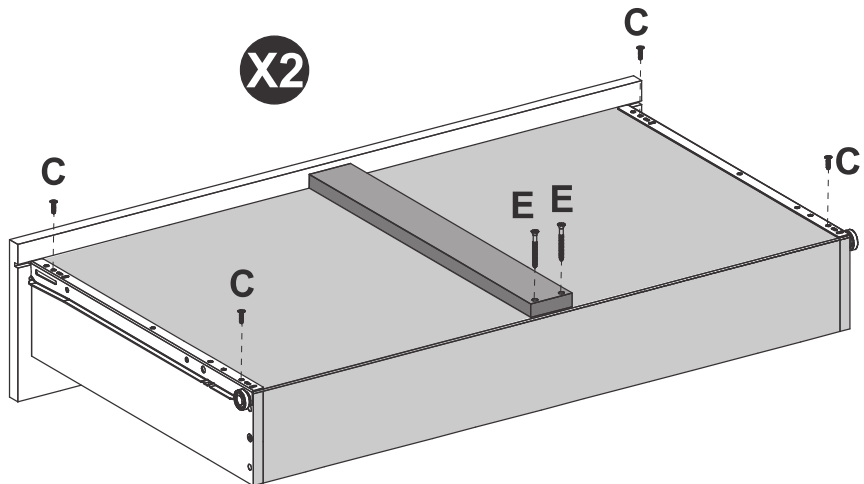



STEP 25

PARTS REQUIRED

11 - LARGE DOOR	x1
13 - RIGHT SMALL DOOR	x1
14 - LEFT SMALL DOOR	x1

HARDWARE REQUIRED

C		18
O		09

TOOLS REQUIRED

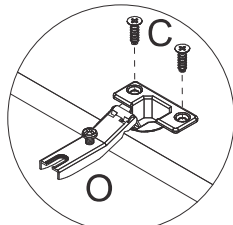
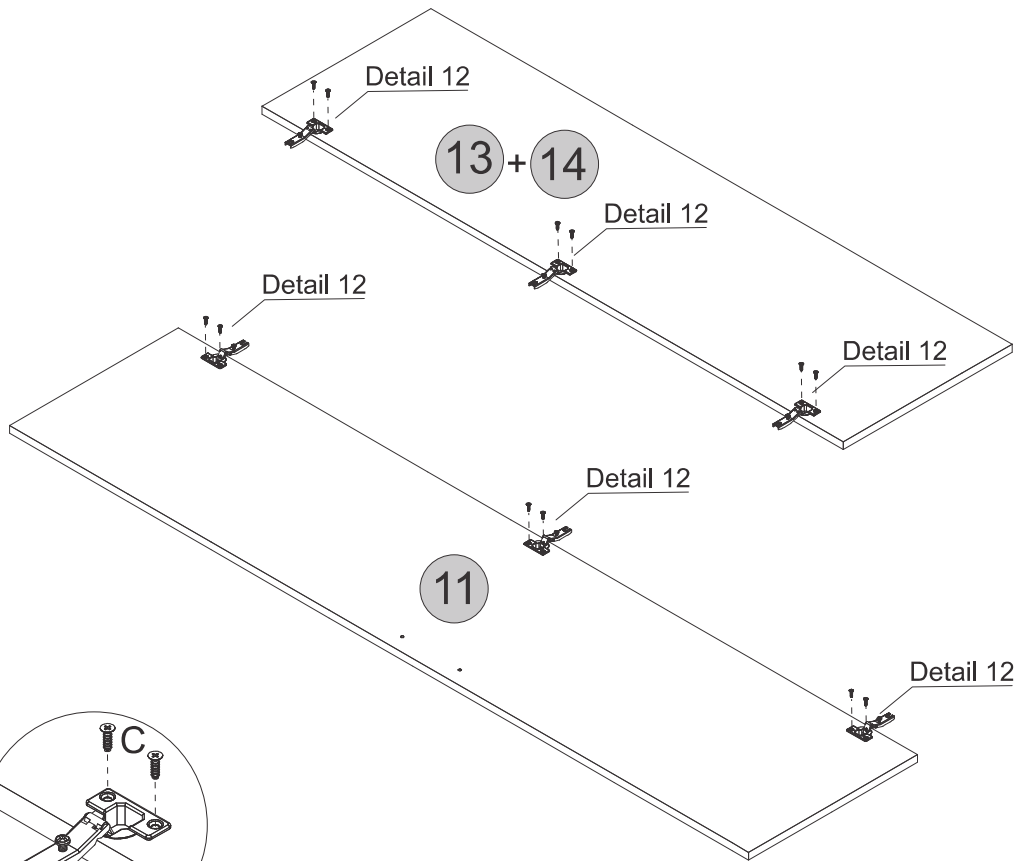
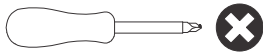

Detail 12

STEP 26

PARTS REQUIRED

11 - LARGE DOOR	x1
13 - RIGHT SMALL DOOR	x1
14 - LEFT SMALL DOOR	x1

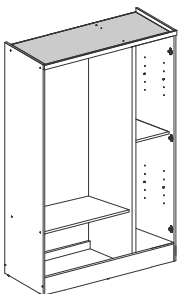

HARDWARE REQUIRED

U		14
---	---	----

TOOLS REQUIRED

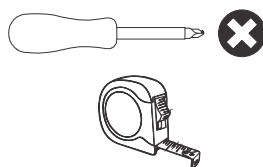

!
Please note the top or bottom edges of the doors are labelled LEFT or RIGHT to make them easier to identify when assembling.

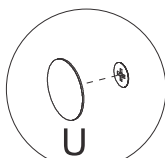
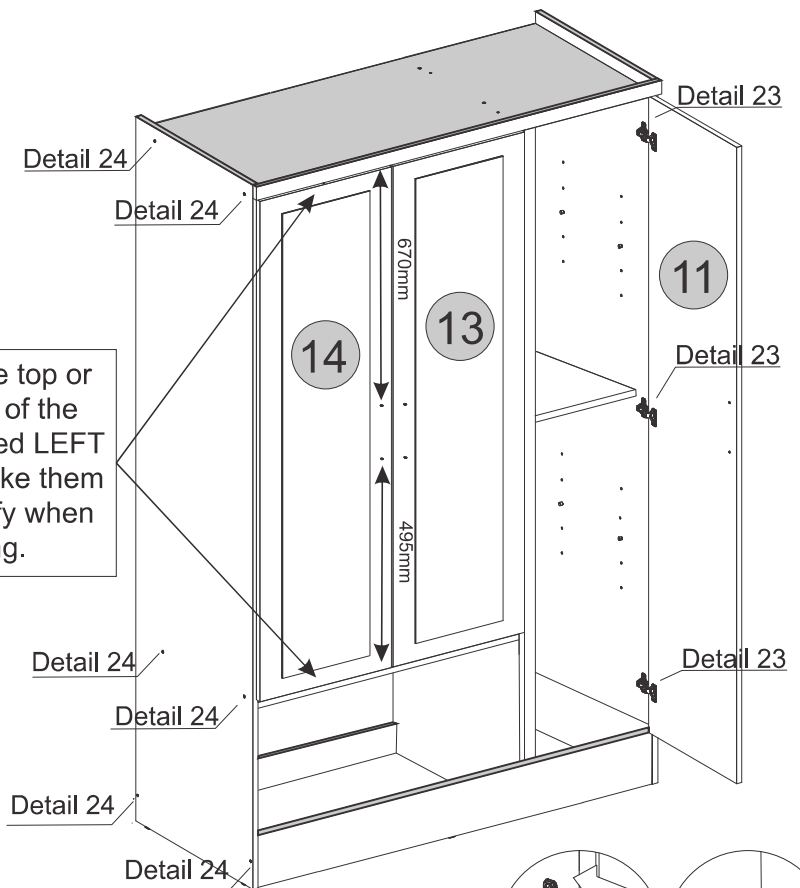

Detail 24

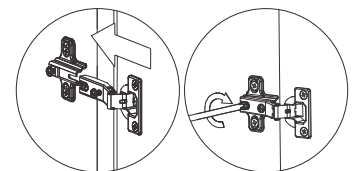

Detail 23

STEP 27

PARTS REQUIRED

12 - MOVEABLE SHELF x2

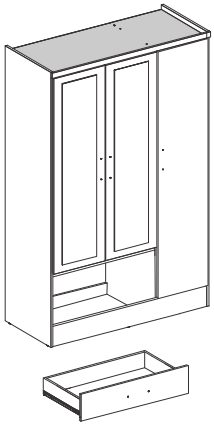

HARDWARE REQUIRED

D  10
Ø4,0 x 22mm

T  05

TOOLS REQUIRED

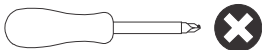

TIP
If desired, after assembly use an alcohol cleaner to erase the number printed on the parts.

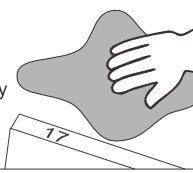

See the last page

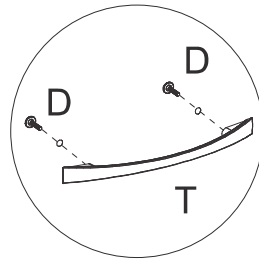
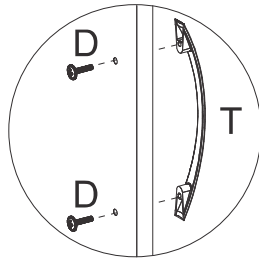
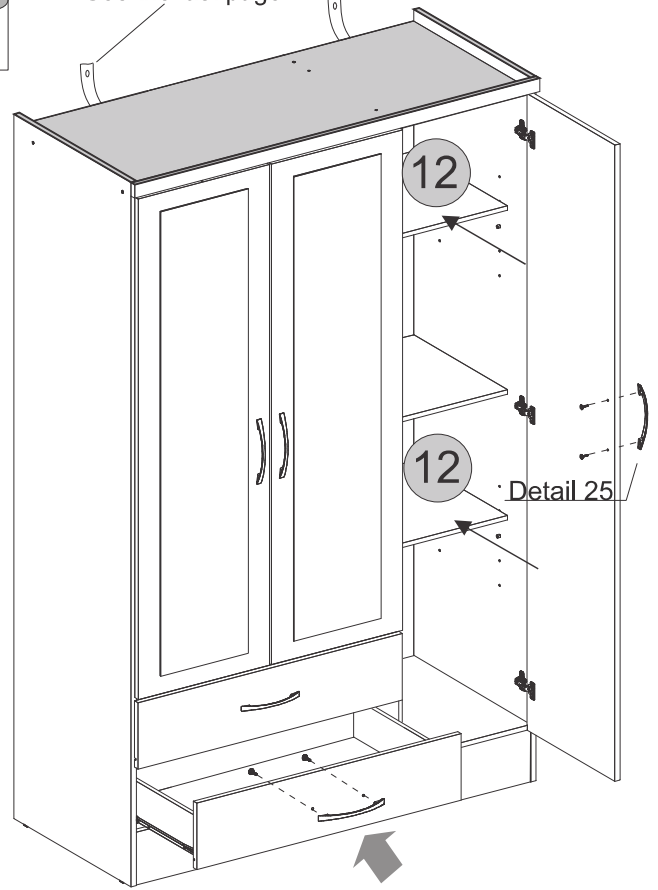

Detail 25

STEP 28

PARTS REQUIRED

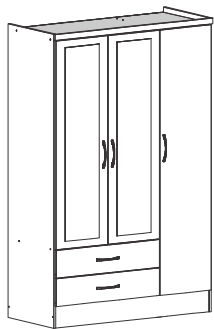

HARDWARE REQUIRED

C  04
Ø4,0 x 14mm

TOOLS REQUIRED

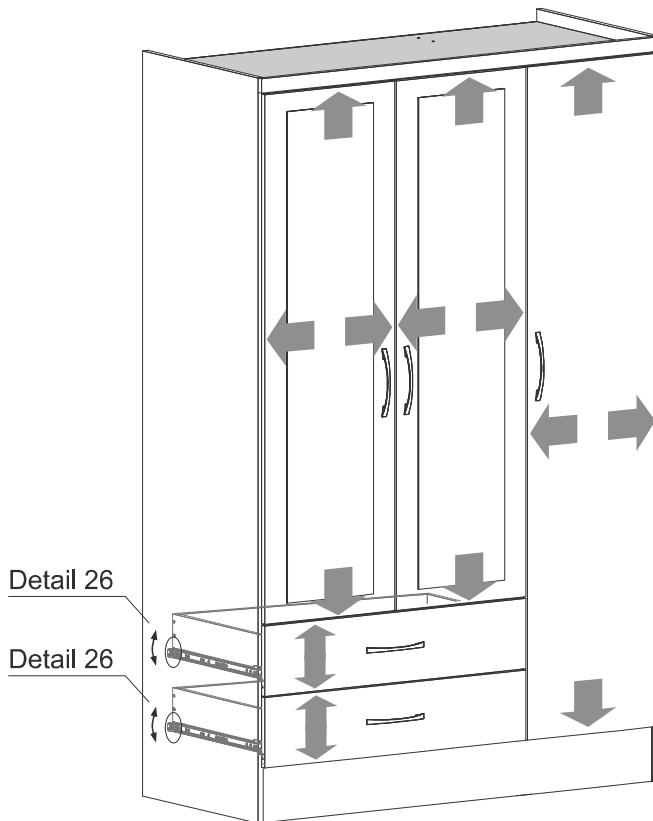
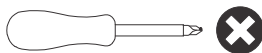

Height Adjustment

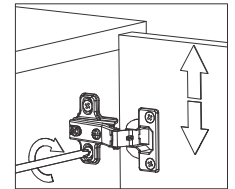

Internal Adjustment

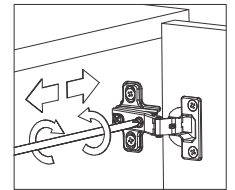

Depth Adjustment

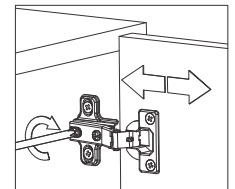
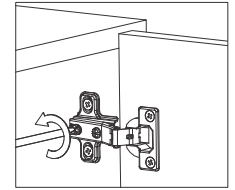

Drawer Adjustment

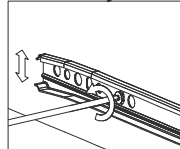

Drawer Lock

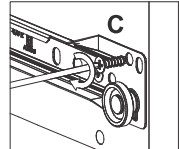

Detail 26

WARNING

Serious or fatal injuries can occur from furniture tipping over. To prevent the furniture from tipping over we recommend that it is permanently fixed to the wall.

Wall fixings are not supplied with this product as different wall materials require different types of fixing devices.

Please make sure you use fixings suitable for the walls in your home.

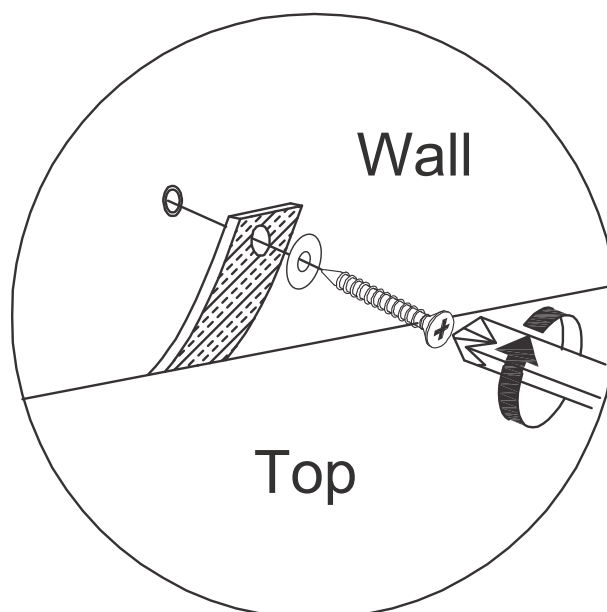
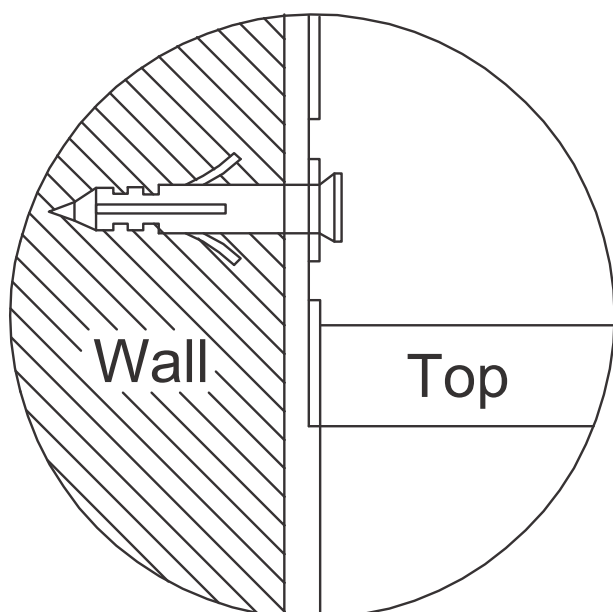
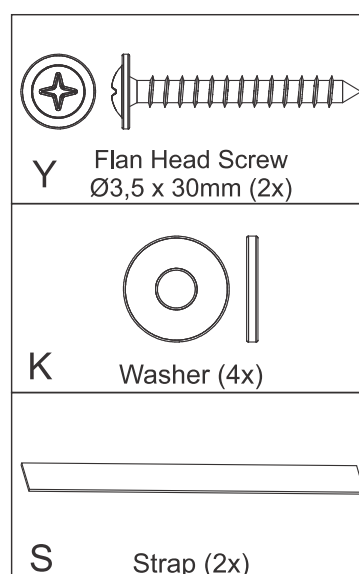
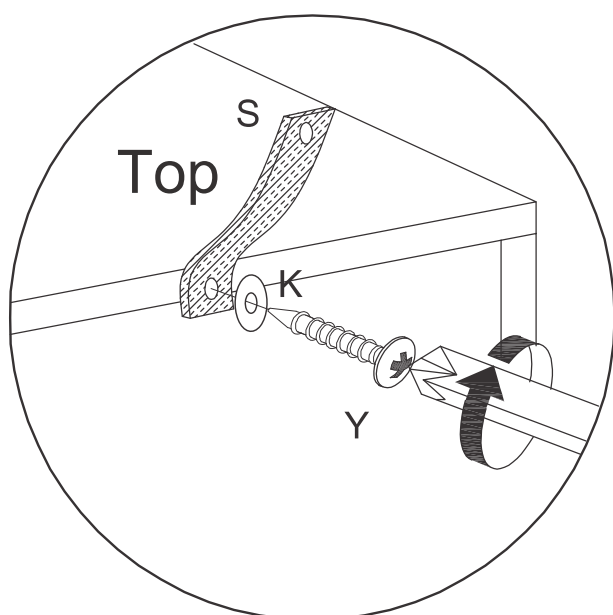

NEVADA 3+2 DRAWER CHEST ASSEMBLY INSTRUCTIONS BLACK GLOSS

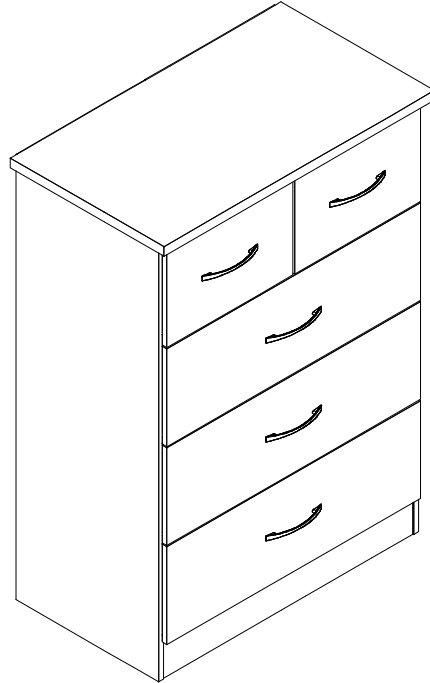

IMPORTANT FOR DOMESTIC USE ONLY PLEASE READ BEFORE YOU CONTINUE FURTHER CARE AND MAINTENANCE

After unpacking this product please keep the original packaging in case it needs to be returned for any reason.

- Please ensure all fittings and parts are present before commencing with assembly.
- Never drag or push products as this could cause damage to the joints making it inferior.
- We strongly recommend that you keep children away from your work area.
- We recommend that you lay a blanket or sheet on the floor to avoid damage to both your floor and the product.
- Assemble this product as close to its final position as possible.
- Do not place this product next to a radiator or in direct sunlight.
- Do not drag or push items across your high gloss furniture as this may cause the surface to scratch
- Wood is a natural product and may expand if subjected to damp and may shrink or crack if subjected to heat. Therefore it is recommended that room temperature is maintained, with no sudden temperature fluctuations.
- Make sure any spillage is wiped off immediately.
- Do not place hot or chilled items directly on to the surface, use a place mat or marking will occur.
- For general cleaning use a soft cotton or micro fibre cloth, and do not use detergents of any kind.
- From time to time it may be necessary to tighten fittings, regular inspections should be carried out.
- Do not place on a wet or damp floor as staining may occur to your floor.

TOOLS REQUIRED

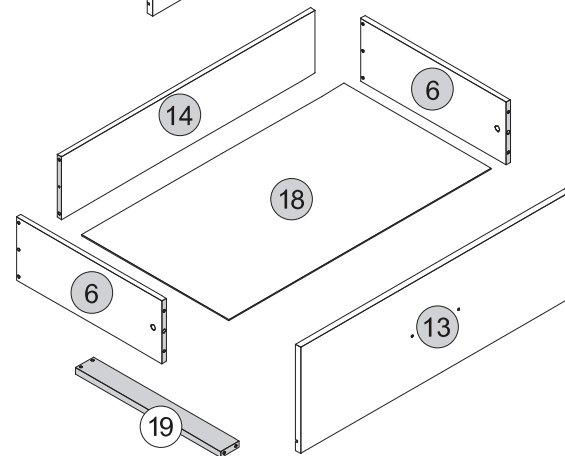
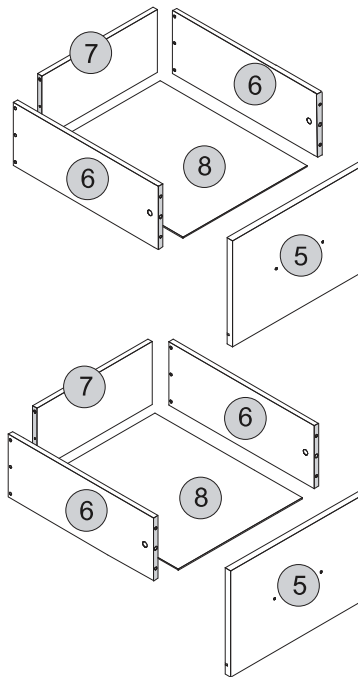
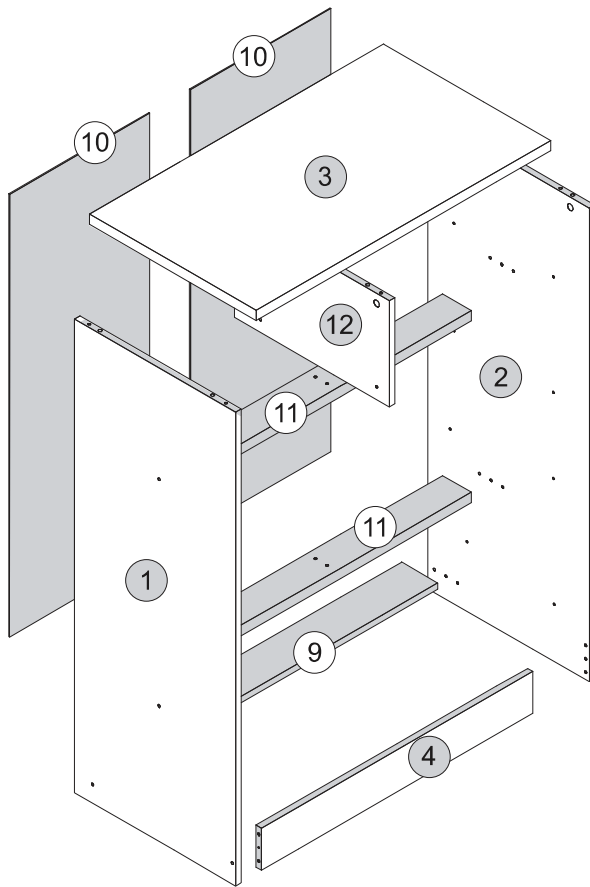
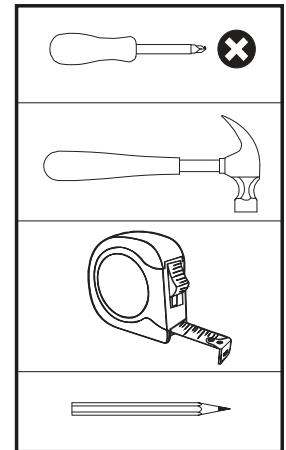











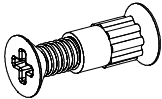
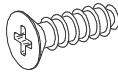
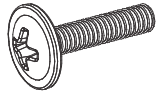
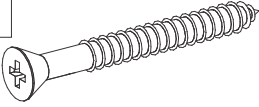
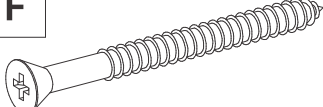
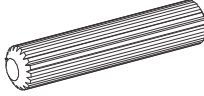

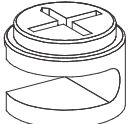
PARTS LIST

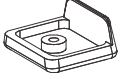
Please Note:
The below parts have all been stamped with the part number to help identify them during assembly.

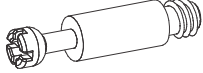
Part Number	Part Code	Part Description	Quantity	Carton
01	S100-102-158-HV1-01	Left Side Panel	1	1/2
02	S100-102-158-HV1-02	Right Side Panel	1	1/2
03	S100-102-158-HV1-03	Top Panel	1	2/2
04	S100-102-158-HV1-04	Front Baseboard	1	1/2
05	S100-102-158-HV1-05	Small Drawer Front	1	2/2
06	S100-102-158-HV1-06	Drawer Side	10	1/2
07	S100-102-158-HV1-07	Small Drawer Back Panel	2	1/2
08	S100-102-158-HV1-08	Small Drawer Bottom	2	1/2
09	S100-102-158-HV1-09	Back Baseboard	1	1/2
10	S100-102-158-HV1-10	Back Panel	1	1/2
11	S100-102-158-HV1-11	Crossbar	2	2/2
12	S100-102-158-HV1-12	Division Panel	1	1/2
13	S100-102-158-HV1-13	Large Drawer Front	3	2/2
14	S100-102-158-HV1-14	Large Drawer Back Panel	3	1/2
18	S100-102-158-HV1-18	Large Drawer Bottom	3	2/2
19	S100-102-158-HV1-19	Drawer Bottom Support Bar	3	1/2

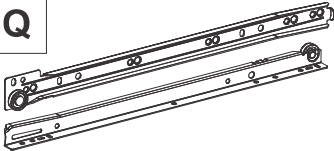
FITTINGS LIST

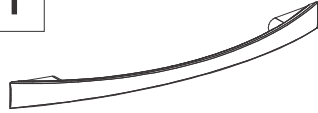
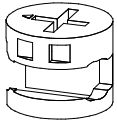
SEC/SH/09/21/HV1

<p>A</p>  <p>Flat Head Screw 2/+ Ø6,0 x 10mm (16x)</p>	<p>B</p>  <p>Double Flat Head Screw 1/+ Ø4,0 x 18mm (2x)</p>	<p>C</p>  <p>Flat Head Screw 2/+ Ø4,0 x 14mm (30x)</p>	<p>D</p>  <p>Flan Head Screw 2/+ Ø4,0 x 20mm (10x)</p>
<p>E</p>  <p>Flat Head Screw 1/+ Ø3,5 x 40mm (6x)</p>	<p>F</p>  <p>Flat Head Screw 2/+ Ø4,0 x 50mm (19x)</p>	<p>G</p>  <p>2/+ Dowel Ø6,0 x 30mm (69x)</p>	<p>H</p>  <p>2/+ Nail 10x10 Ringed-1,5x23mm (84x)</p>
<p>I</p>  <p>1/+ Back Panel Bracket 14x14mm (2x)</p>	<p>J</p>  <p>2/+ Cam Nut Ø12x8,8MM (10x)</p>	<p>K</p>  <p>1/+ Washer Ø16x7 (4x)</p>	<p>L</p>  <p>1/+ Plastic Foot L 19x17x8mm Ø2 (6x)</p>
<p>M</p>  <p>Flan Head Screw 1/+ Ø3,5 x 30mm (2x)</p>	<p>N</p>  <p>2/+ Cam Bolt (16x)</p>	<p>O</p>  <p>2/+ Hole Plugs 19MM (9x)</p>	<p>P</p>  <p>Glue 10Gr (3x)</p>
<p>Q</p>  <p>Drawer Runners 400MM (5x)</p>	<p>R</p>  <p>Back Panel Strip H 799x19x3,8mm (1x)</p>	<p>S</p>  <p>Strap 200x20x1MM (2x)</p>	<p>T</p>  <p>Handle (5x)</p>
<p>U</p>  <p>1/+ Cam Nut Ø14,9x11MM (6x)</p>	<p>V</p>  <p>+2 Hole Plugs Líneo 19mm (9x)</p>		

TIPS FOR FITTINGS CAM-LOCKS

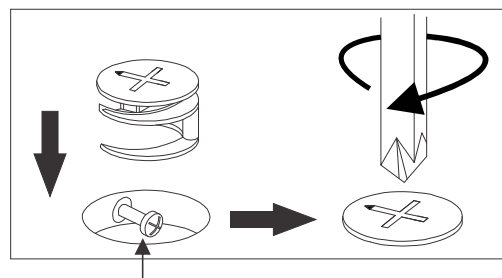
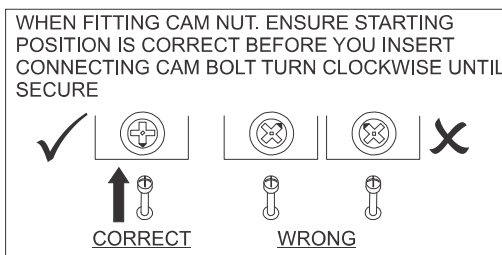

Cam bolt head needs to be in centre

CAMBOLT

Tighten until shoulder is flush with panel. Do not overtighten or undertighten (see example below)

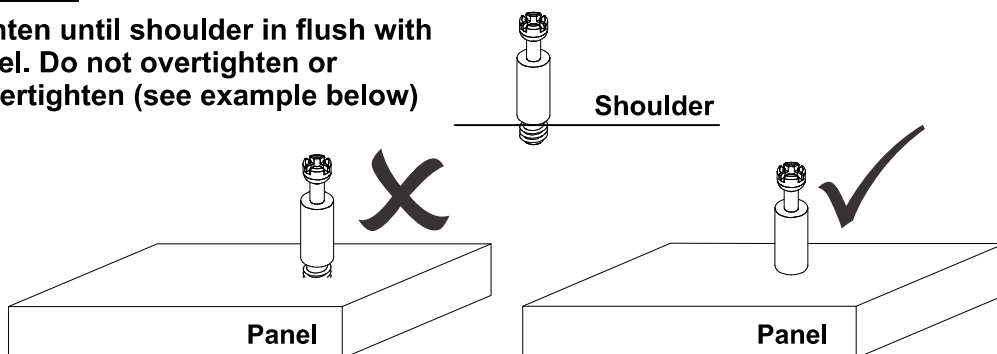



STEP 1

PARTS REQUIRED

1 - LEFT SIDE PANEL x1

HARDWARE REQUIRED

G  02
Ø6 x 30

H  02
10 x 10

L  02

P  01
GLUE

TOOLS REQUIRED

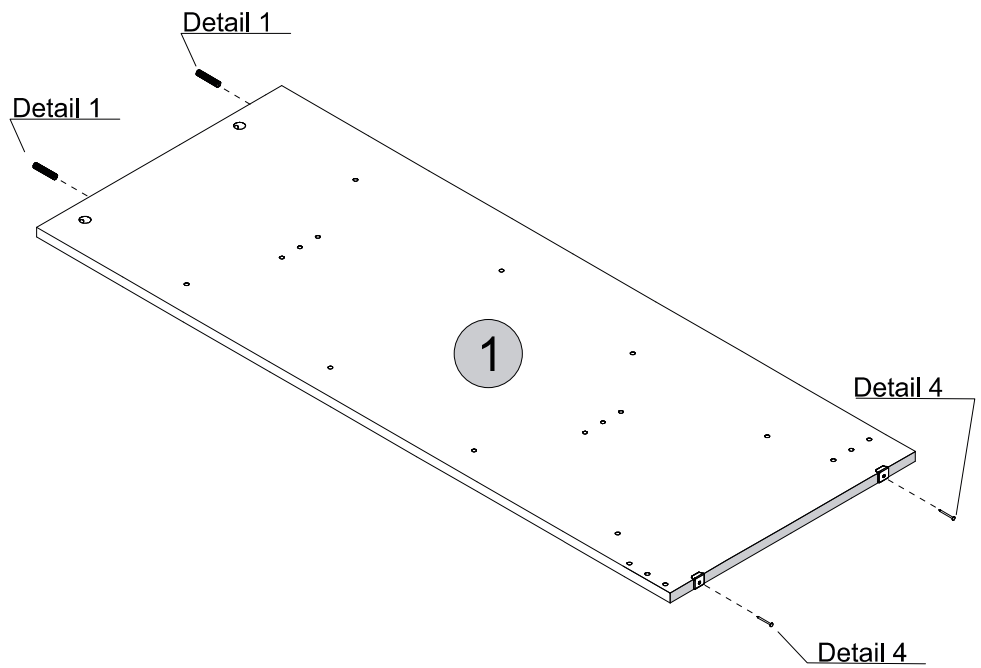
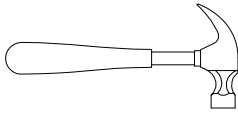

Detail 1

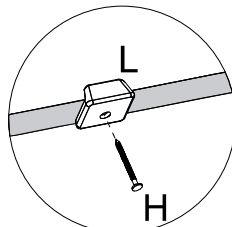

Detail 4

STEP 2

PARTS REQUIRED

2 - RIGHT SIDE PANEL x1

HARDWARE REQUIRED

G  02
Ø6 x 30

H  02
10 x 10

L  02

P  01
GLUE

TOOLS REQUIRED

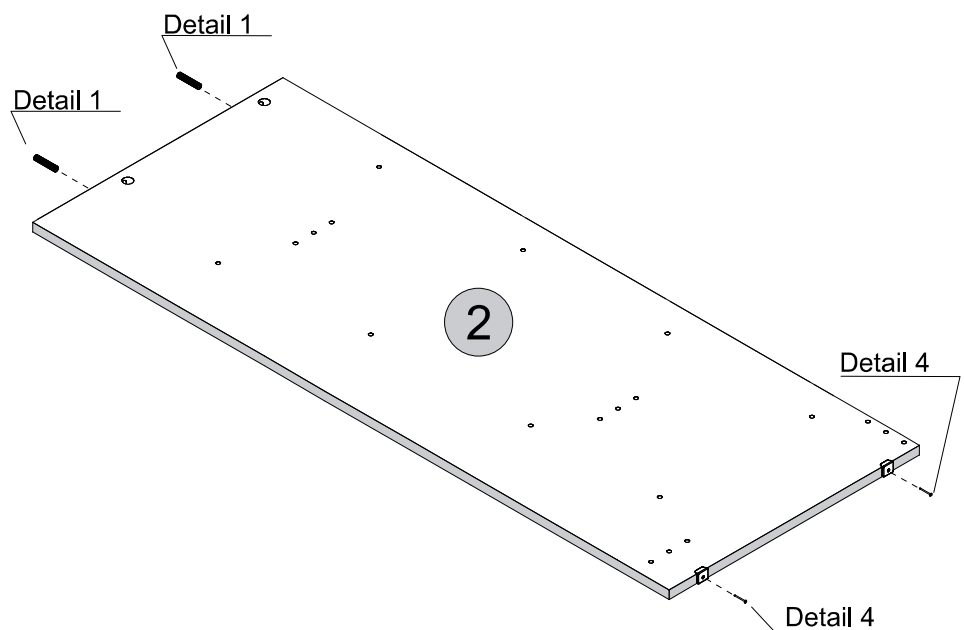
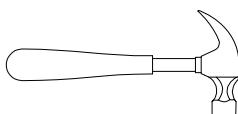

Detail 1

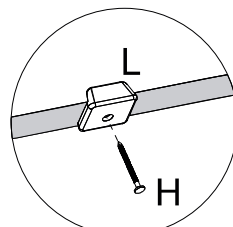

Detail 4

STEP 3

PARTS REQUIRED

1 - LEFT SIDE PANEL x1

HARDWARE REQUIRED

A  08
Ø6 x 10

Q  04
LEFT

TOOLS REQUIRED

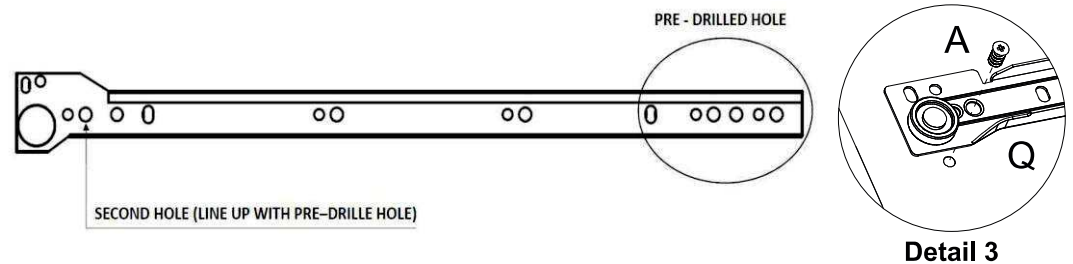
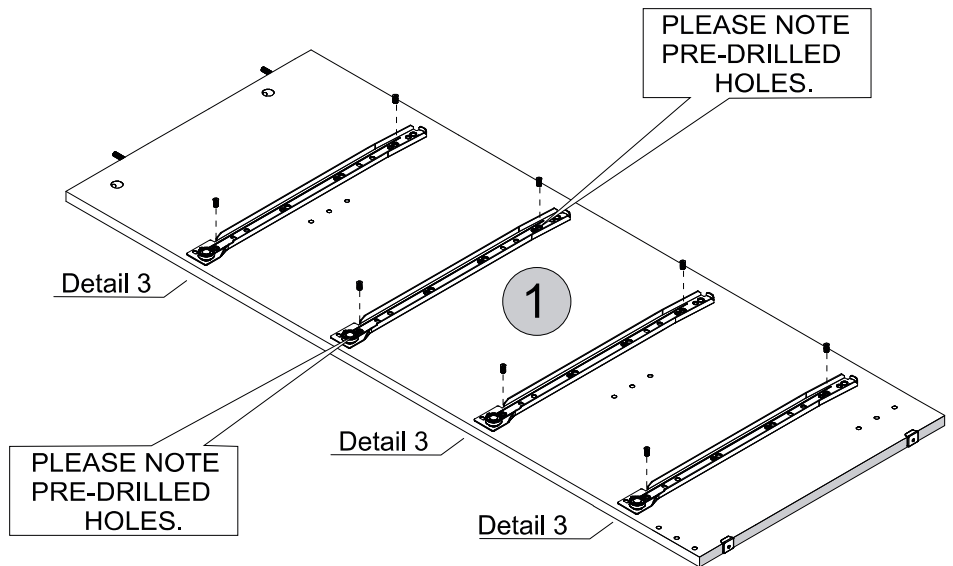
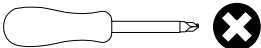



STEP 4

PARTS REQUIRED

2 - RIGHT SIDE PANEL x1

HARDWARE REQUIRED

A  08
Ø6 x 10

Q  04
RIGHT

TOOLS REQUIRED

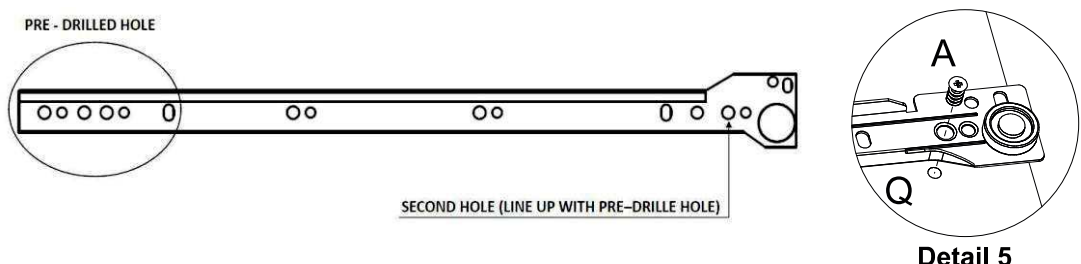
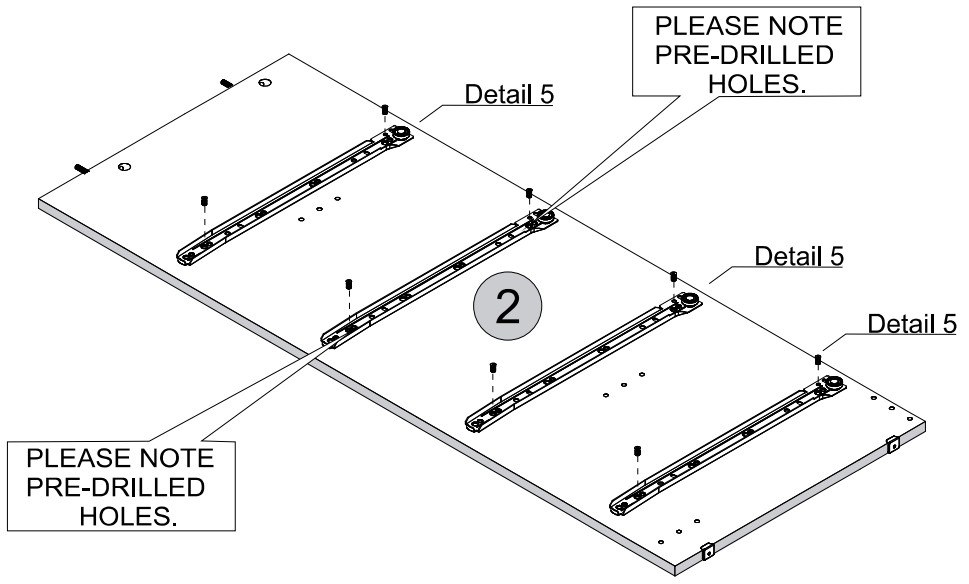
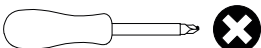

STEP 5

PARTS REQUIRED

4 - FRONT BASEBOARD x1

9 - BACK BASEBOARD x1

11 - CROSSBAR x2

HARDWARE REQUIRED

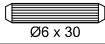
G  16
Ø6 x 30

H  02
10 x 10

L  02

P  01
GLUE

TOOLS REQUIRED

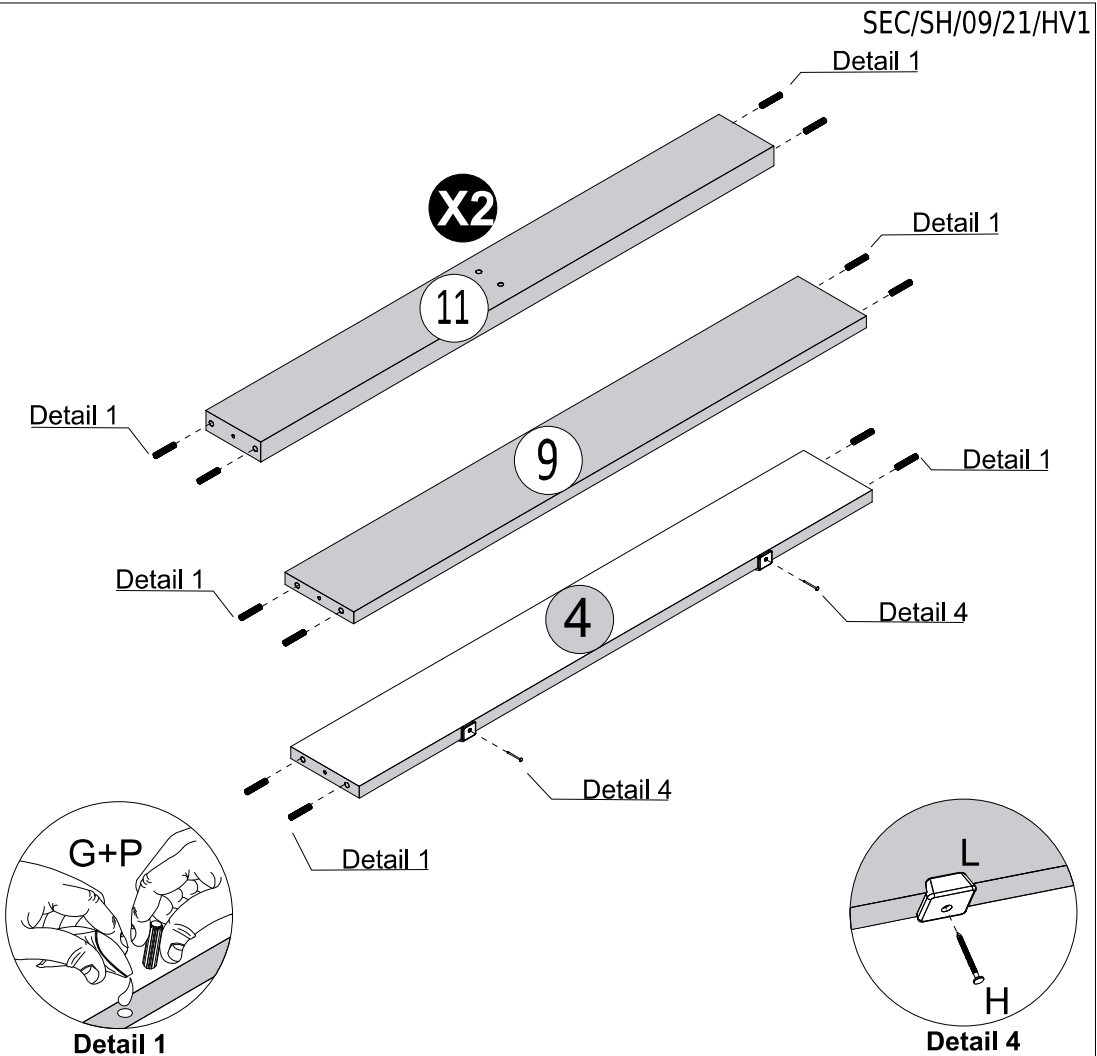
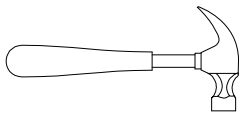

STEP 6

PARTS REQUIRED

12 - DIVISION PANEL x1

HARDWARE REQUIRED

B  02
Ø4.0 x 18mm

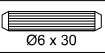
G  03
Ø6 x 30

P  01
GLUE

Q  01
LEFT

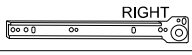
Q  01
RIGHT

TOOLS REQUIRED

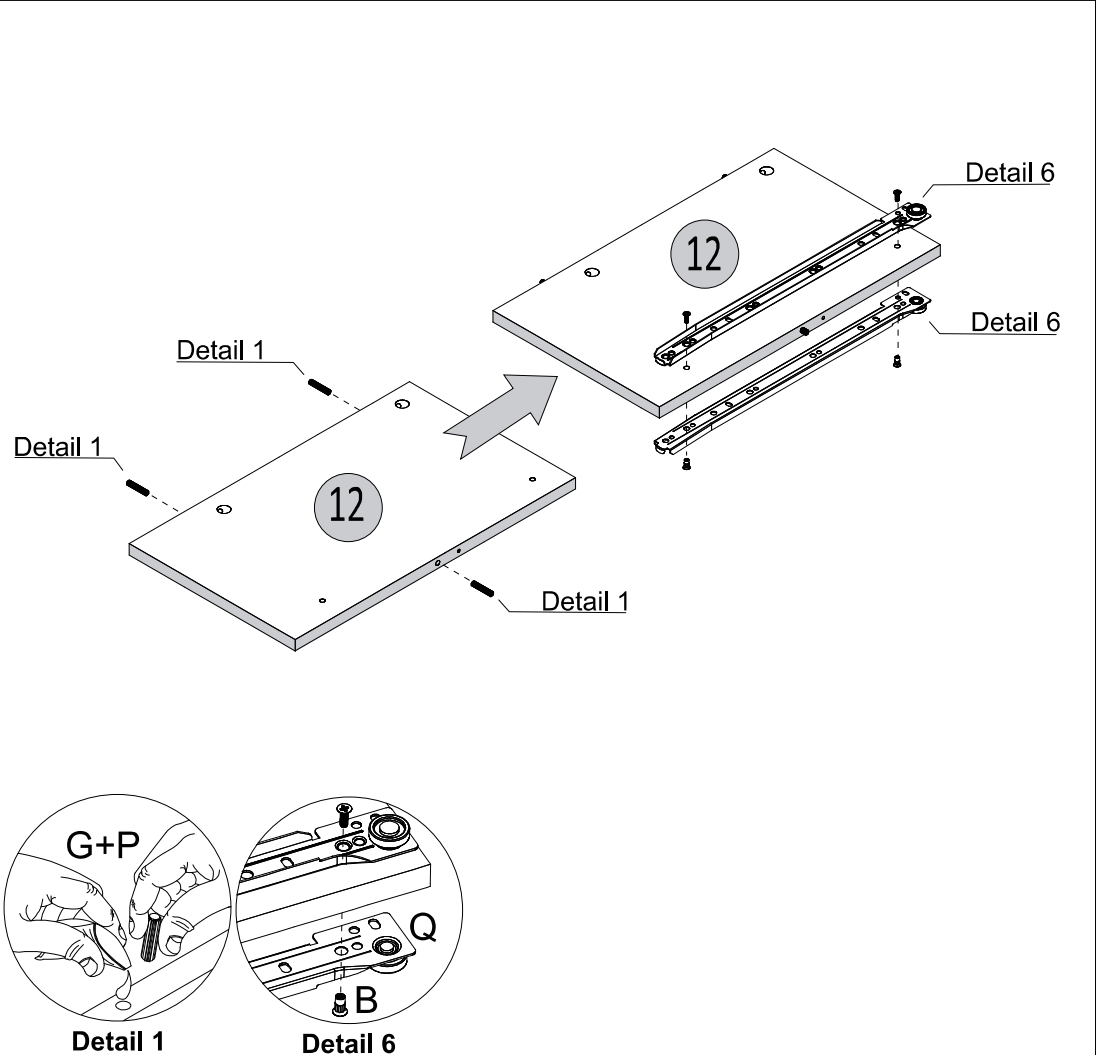
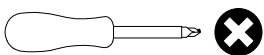



STEP 7

PARTS REQUIRED

- 2 - RIGHT SIDE PANEL x1
- 4 - FRONT BASEBOARD x1
- 9 - BACK BASEBOARD x1
- 11 - CROSSBAR x2

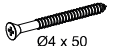
HARDWARE REQUIRED

- F  04
Ø4 x 50
- P  01

TOOLS REQUIRED

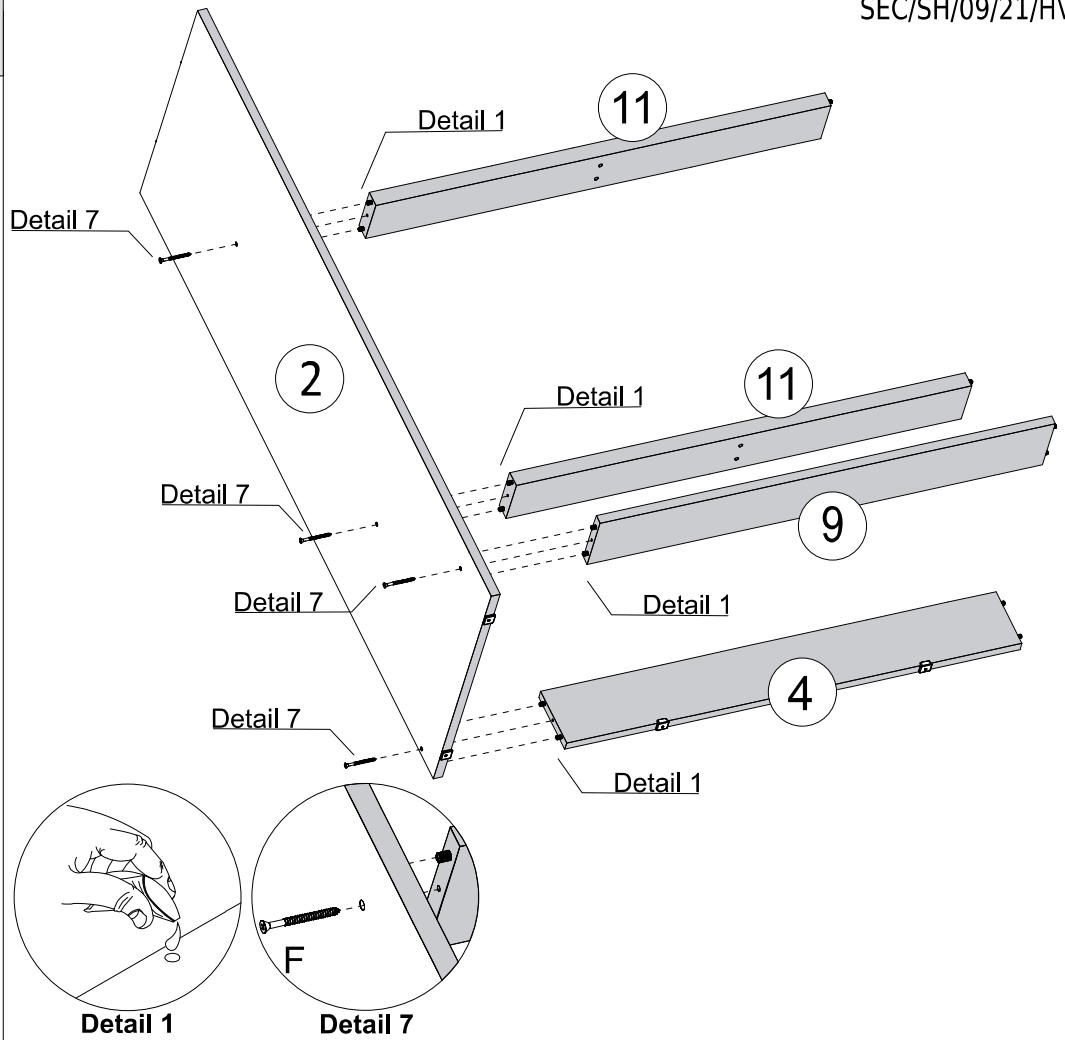
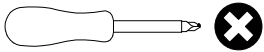



STEP 8

PARTS REQUIRED

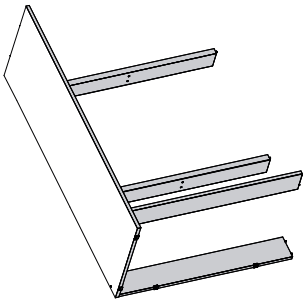
- 1 - LEFT SIDE PANEL x1

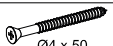

HARDWARE REQUIRED

- F  04
Ø4 x 50
- P  01

TOOLS REQUIRED

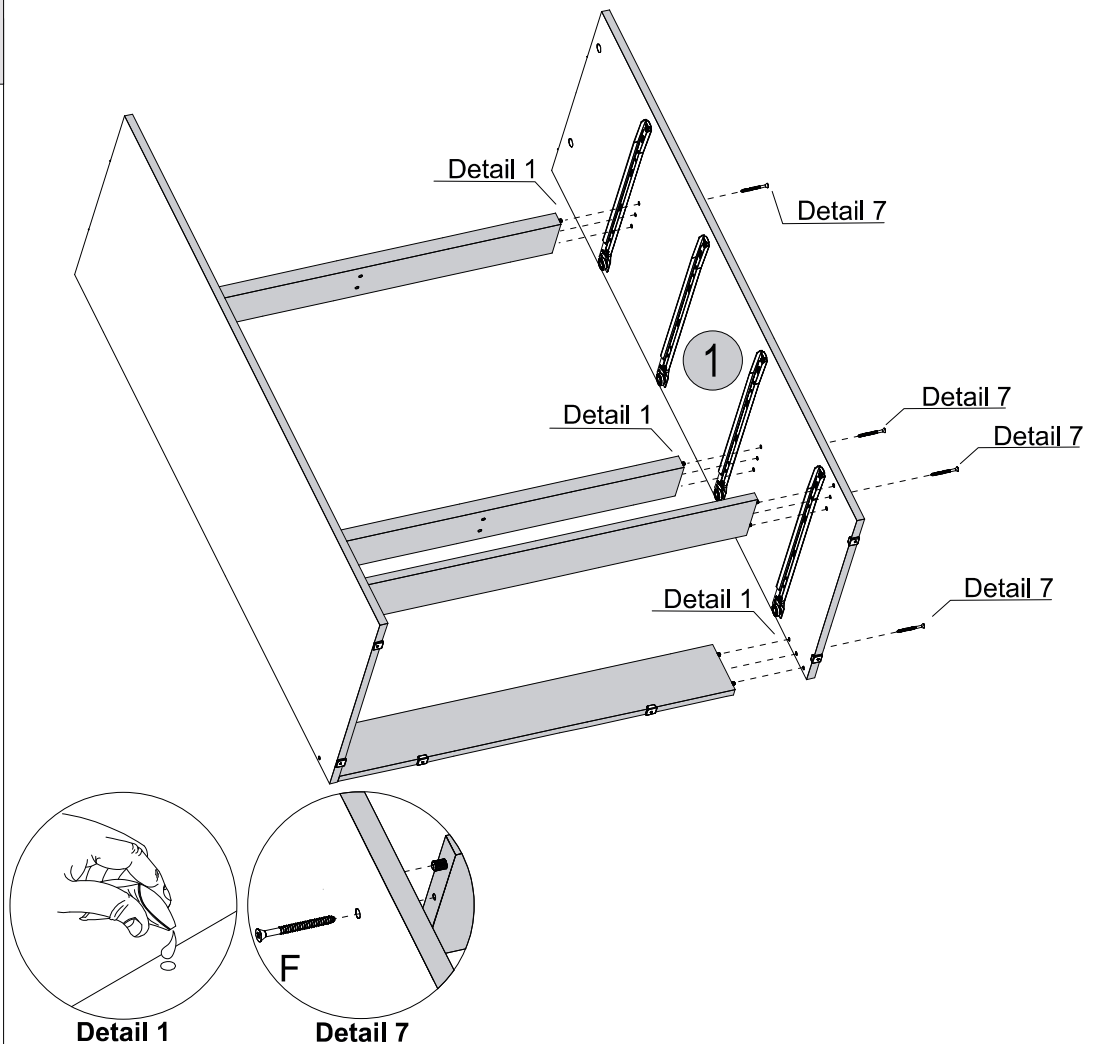
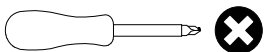

STEP 9

PARTS REQUIRED

3 - TOP PANEL x1

HARDWARE REQUIRED

N  06

TOOLS REQUIRED

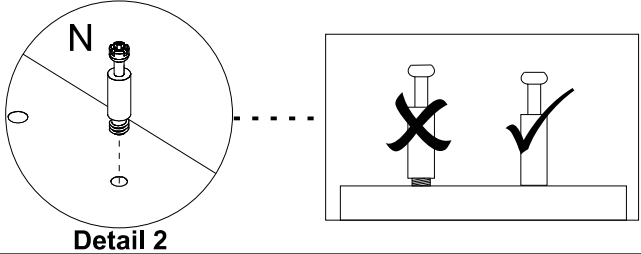
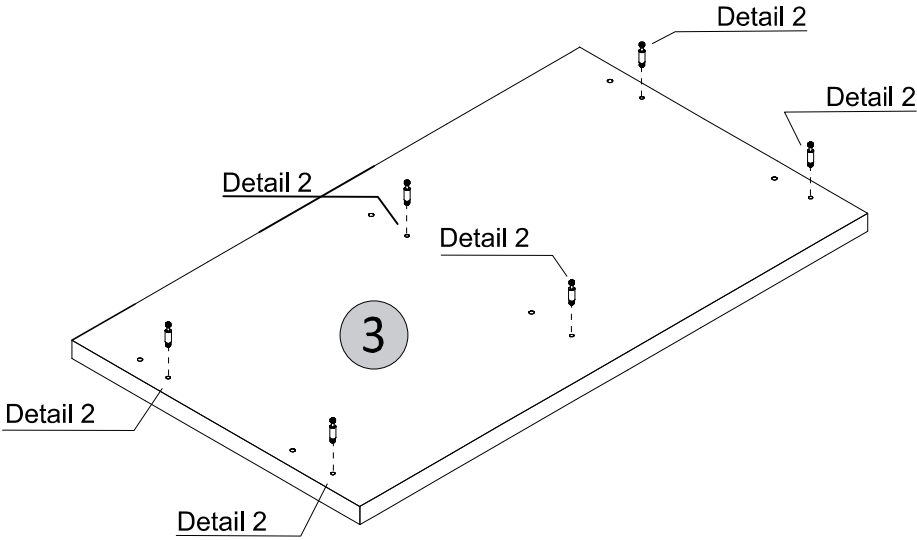
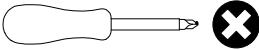

Detail 2

STEP 10

PARTS REQUIRED

3 - TOP PANEL x1

12 - DIVISION PANEL x1

HARDWARE REQUIRED

U  02

TOOLS REQUIRED

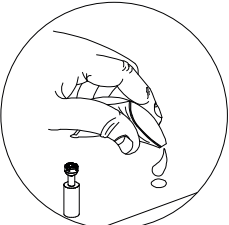
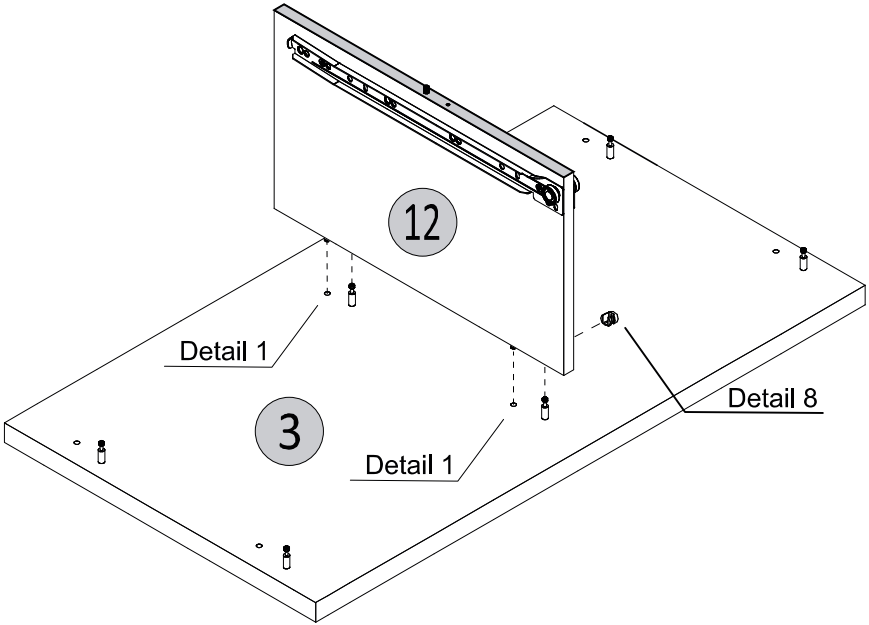
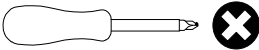

Detail 1

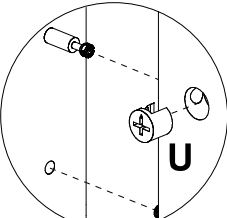

Detail 8

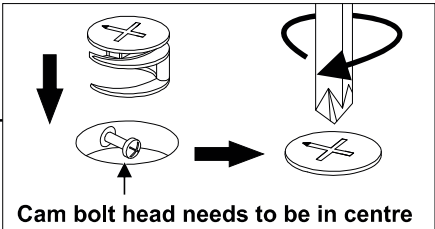

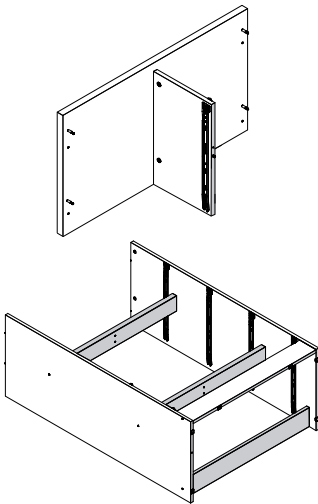

STEP 11

PARTS REQUIRED



HARDWARE REQUIRED

F		01
P		01
U		04

TOOLS REQUIRED

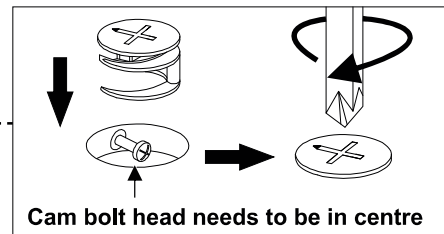
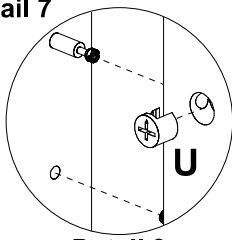
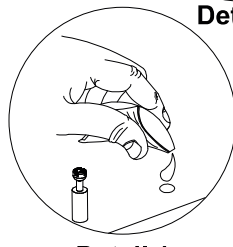
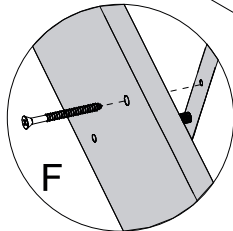
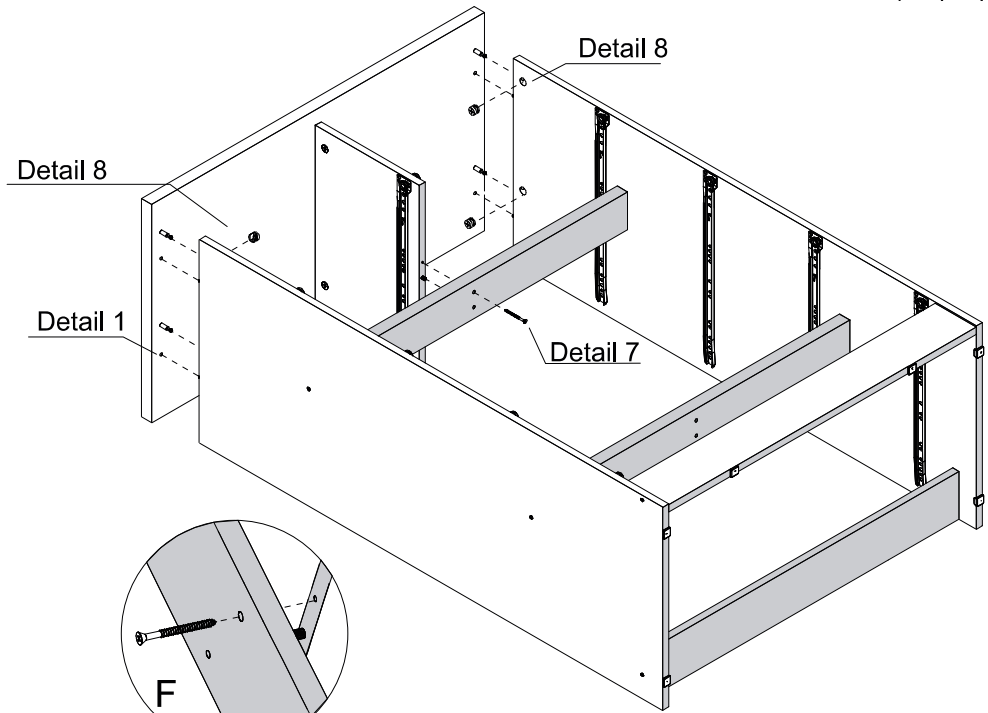
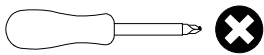



STEP 12

PARTS REQUIRED

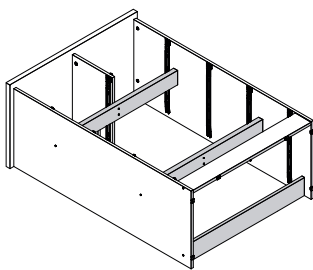
10 - BACK PANEL	x2
-----------------	----



HARDWARE REQUIRED

H		32
I		02
R		01

TOOLS REQUIRED

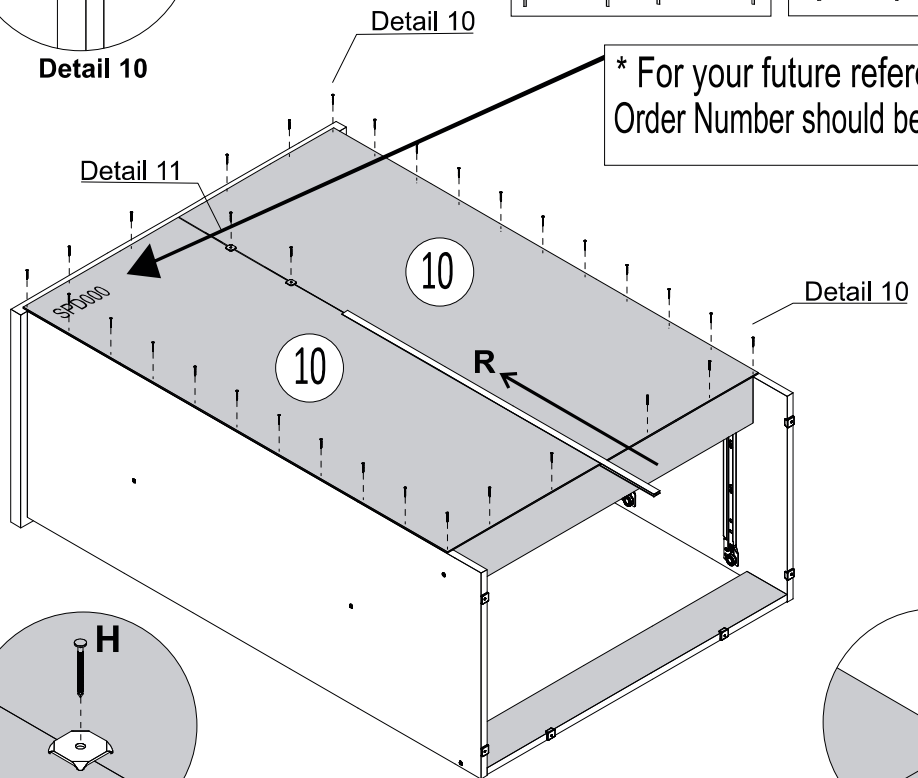
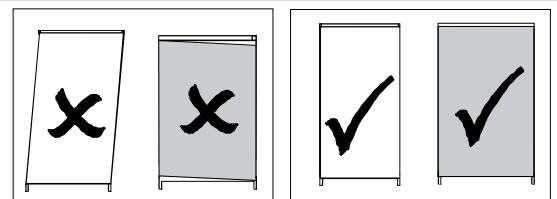
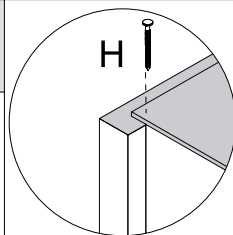
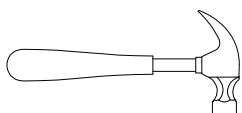

* For your future reference
Order Number should be here

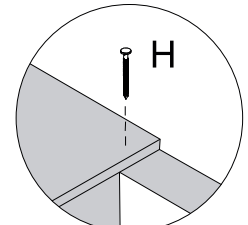
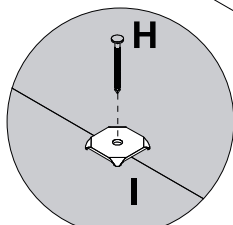



STEP 13

PARTS REQUIRED

- 6 - DRAWER SIDE x10
- 7 - SMALL DRAWER BACK PANEL x2
- 14 - LARGE DRAWER BACK PANEL x3
- 19 - DRAWER BOTTOM SUPPORT BAR x3

HARDWARE REQUIRED

- G  46
- P  01

TOOLS REQUIRED



Detail 1

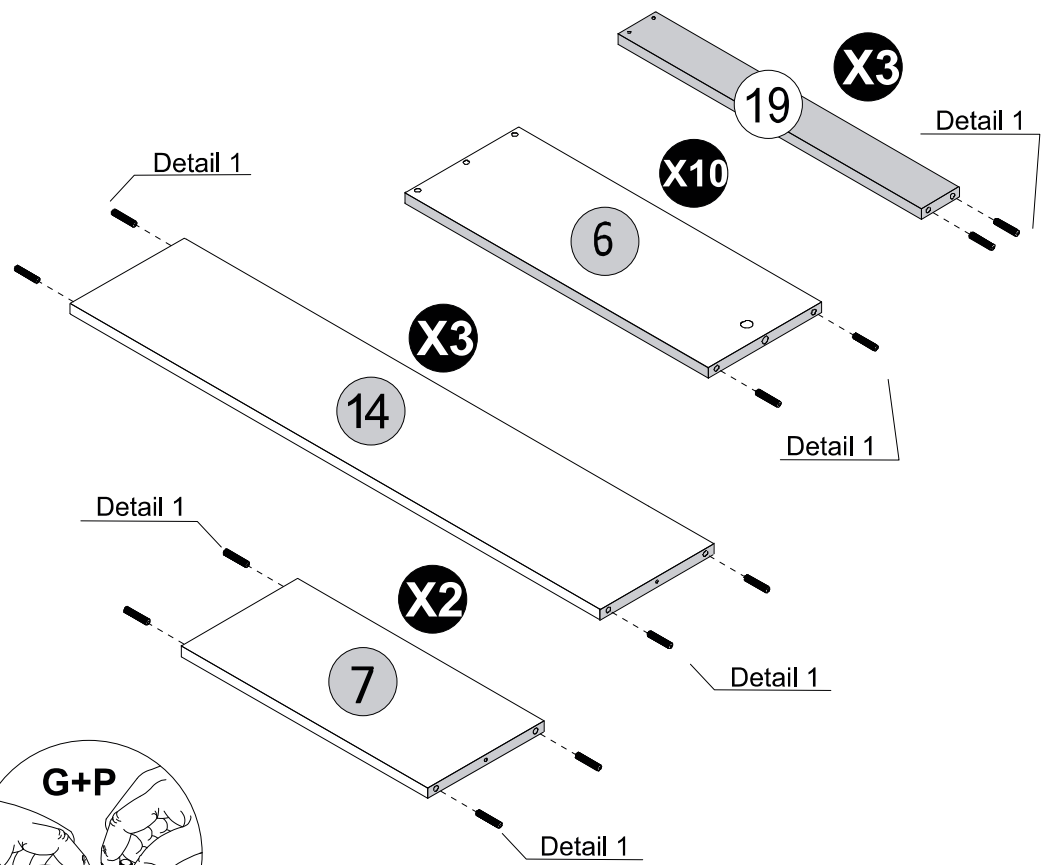

STEP 14

PARTS REQUIRED

- 13 - LARGE DRAWER FRONT x3
- 5 - SMALL DRAWER FRONT x2

HARDWARE REQUIRED

- N  10

TOOLS REQUIRED

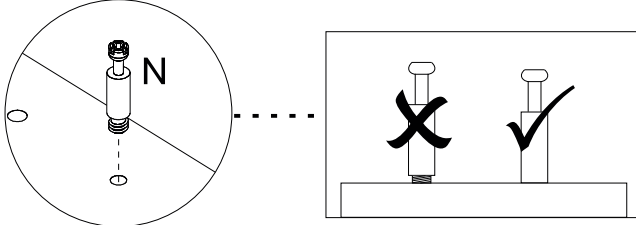
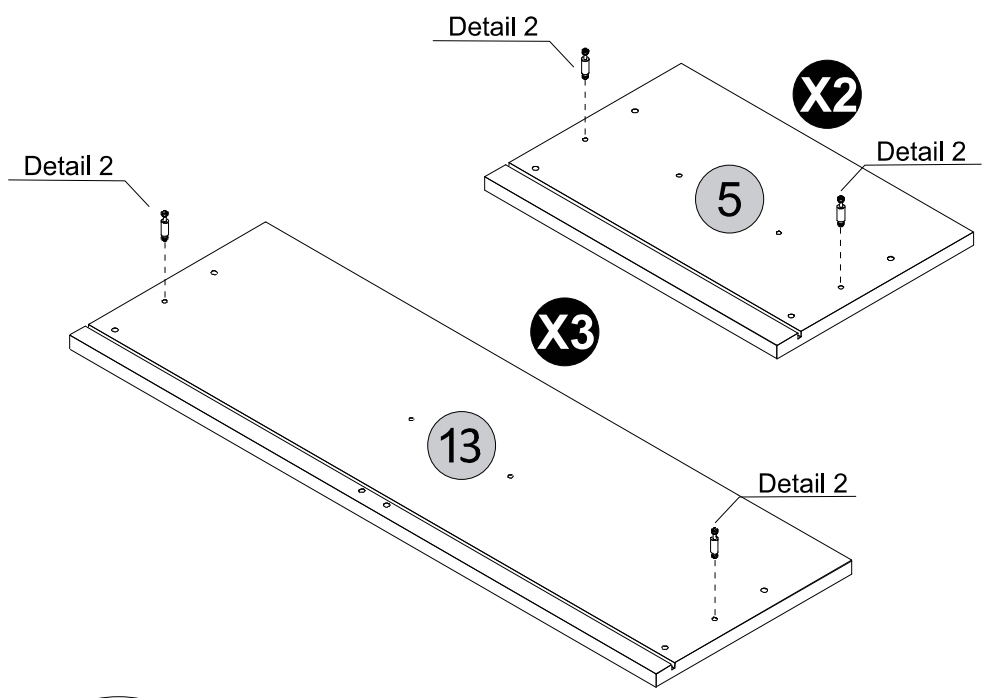
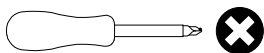

Detail 2

STEP 15

PARTS REQUIRED

6 - DRAWER SIDE x6

14 - LARGE DRAWER BACK PANEL x3

HARDWARE REQUIRED

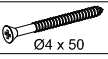
F  06
Ø4 x 50

TOOLS REQUIRED

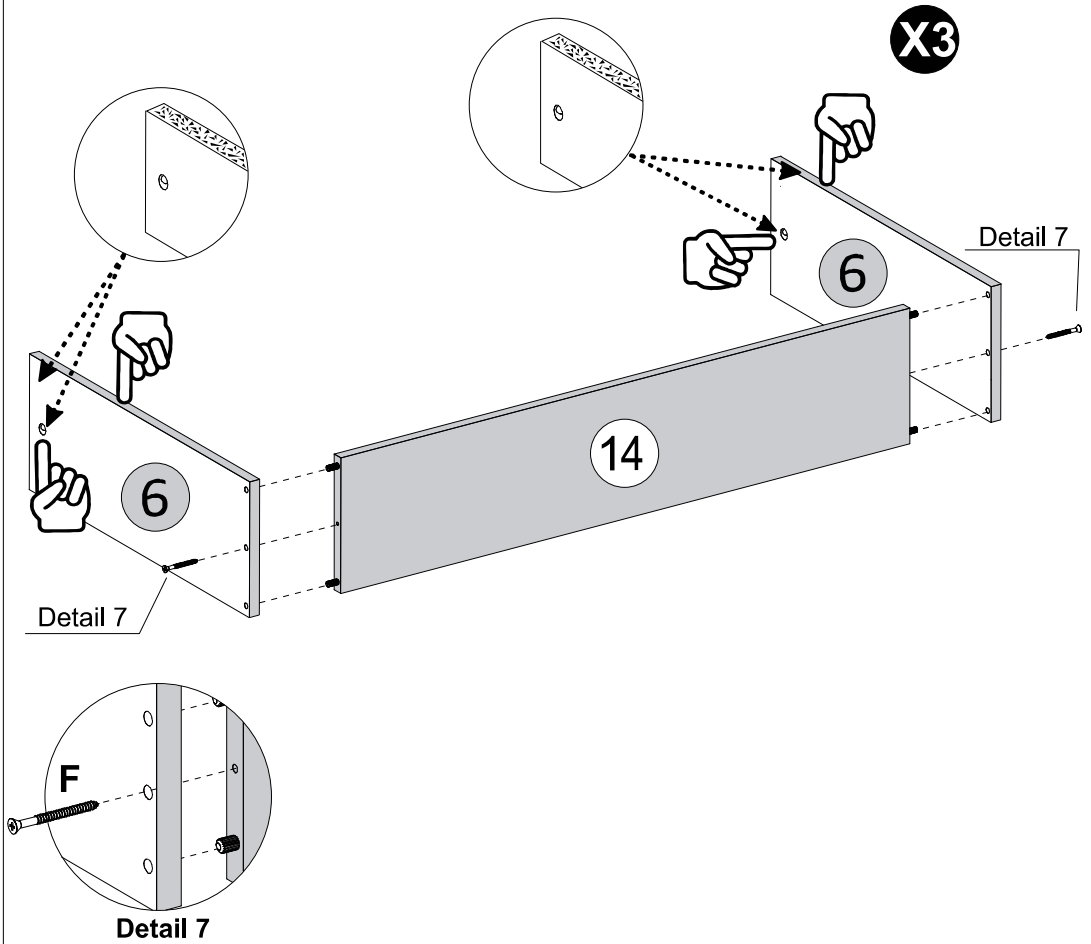
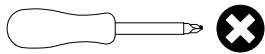

STEP 16

PARTS REQUIRED

13 - LARGE DRAWER FRONT x3

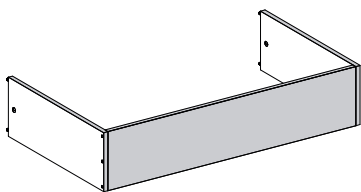

HARDWARE REQUIRED

J  06

P  01
GLUE

TOOLS REQUIRED

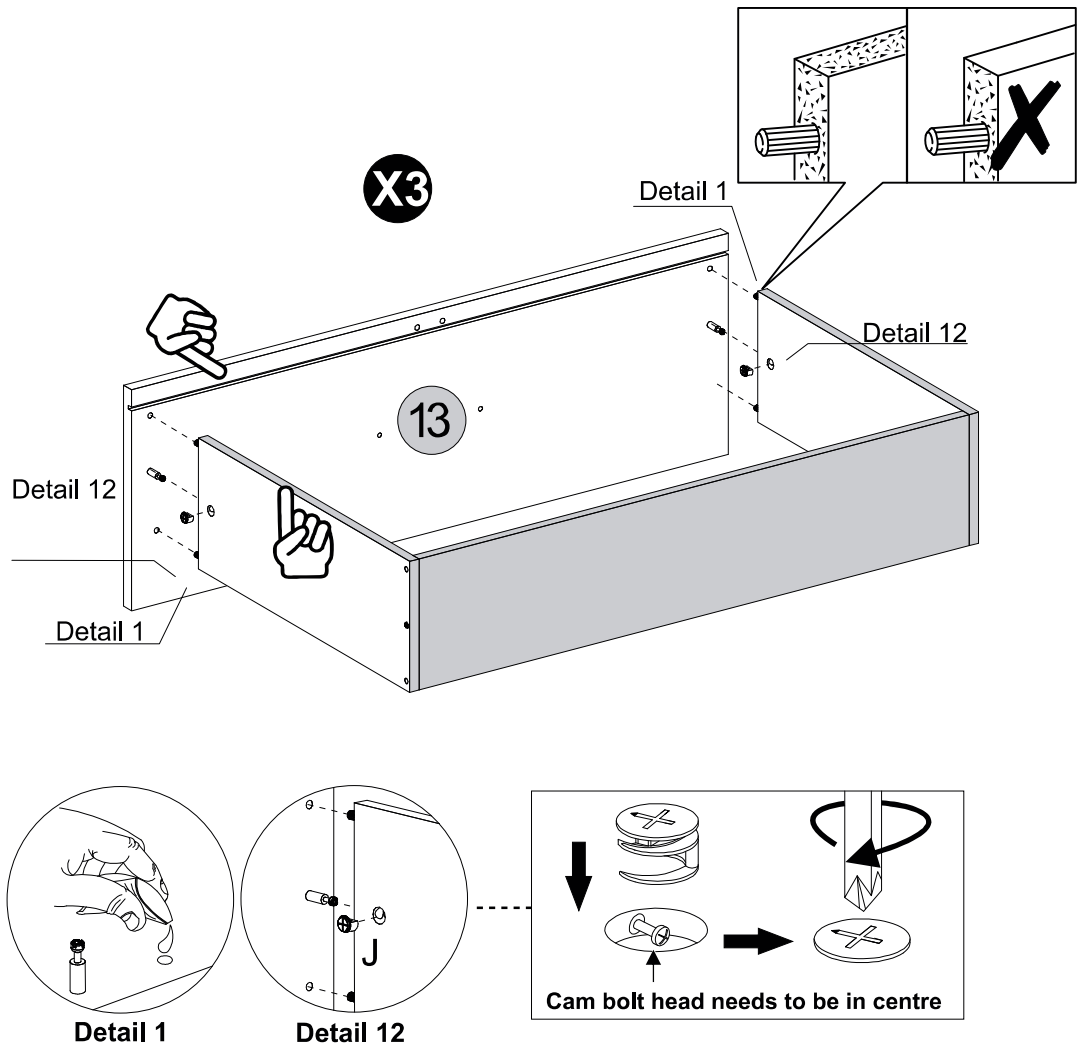
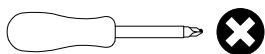

STEP 17

PARTS REQUIRED

18 -LARGE DRAWER BOTTOM x3

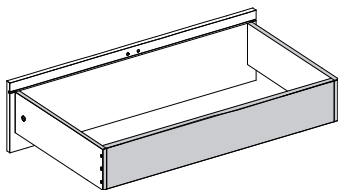

HARDWARE REQUIRED

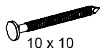
H  12
10 x 10

TOOLS REQUIRED

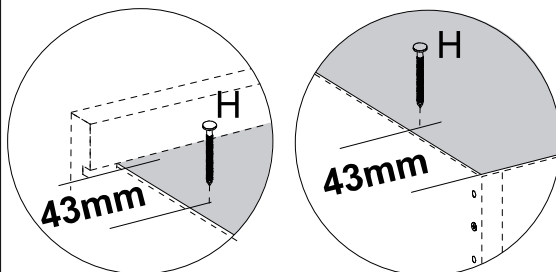
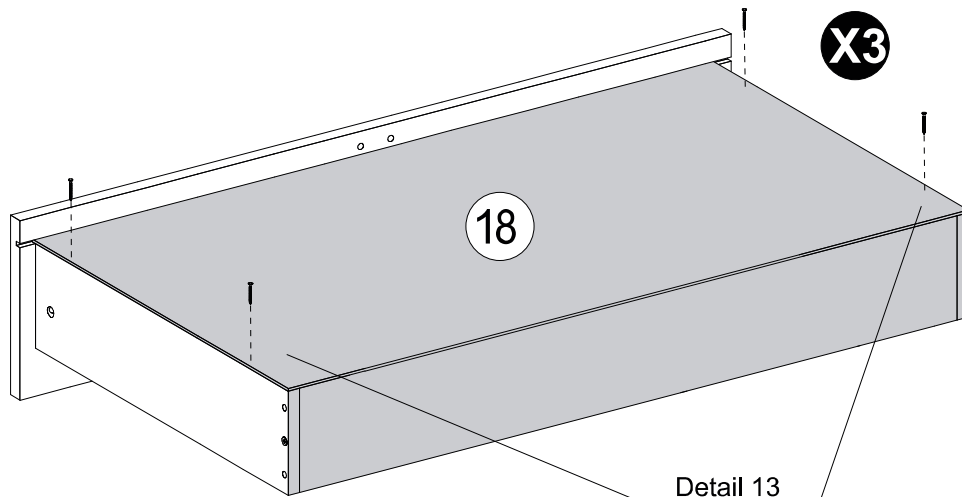
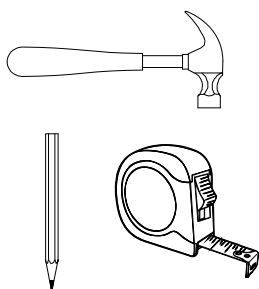

Detail 13

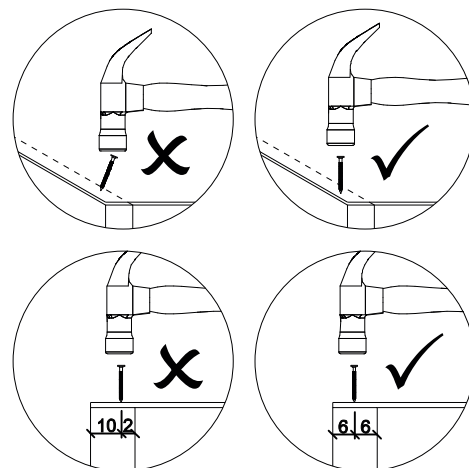

STEP 18

PARTS REQUIRED

19 -DRAWER BOTTOM SUPPORT BAR x3

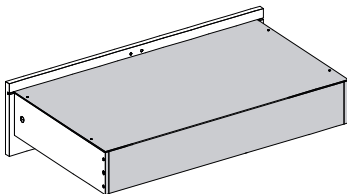

HARDWARE REQUIRED

H  18
10 x 10

P  01
GLUE

TOOLS REQUIRED

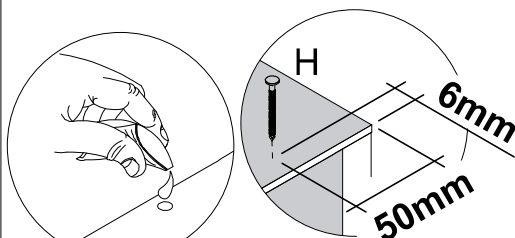
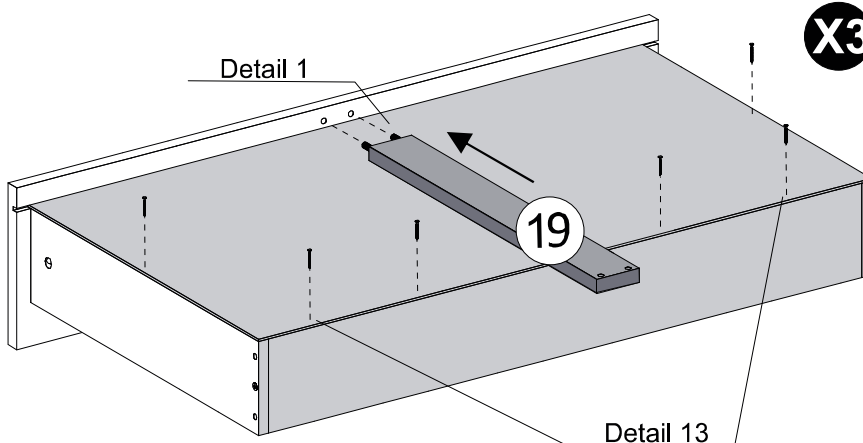
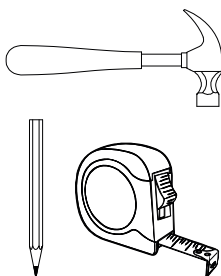

Detail 1

Detail 13

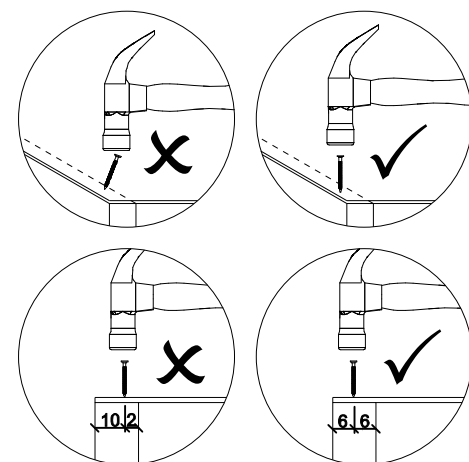

STEP 19

PARTS REQUIRED

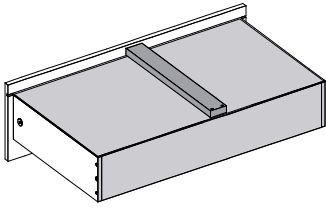

HARDWARE REQUIRED

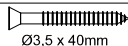
C	 Ø4,0 x 14mm	12
E	 Ø3,5 x 40mm	06
Q	LEFT	03
Q	RIGHT	03

TOOLS REQUIRED

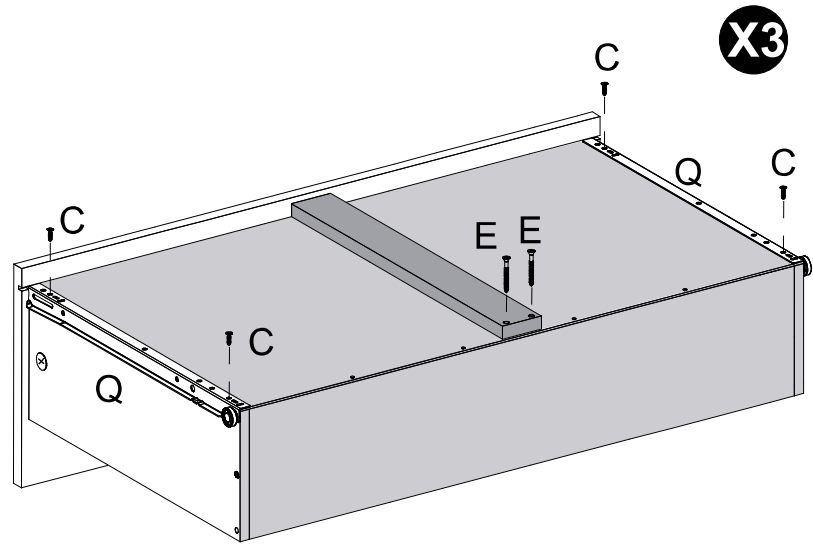
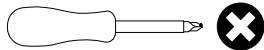

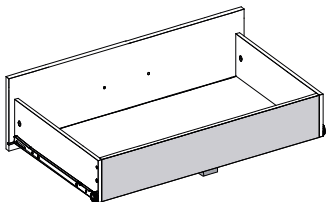

STEP 20

PARTS REQUIRED

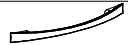

HARDWARE REQUIRED

D	 4 x 22	06
T		03
V		06

TOOLS REQUIRED

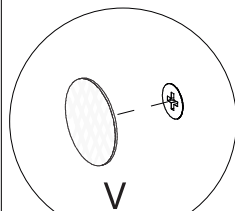
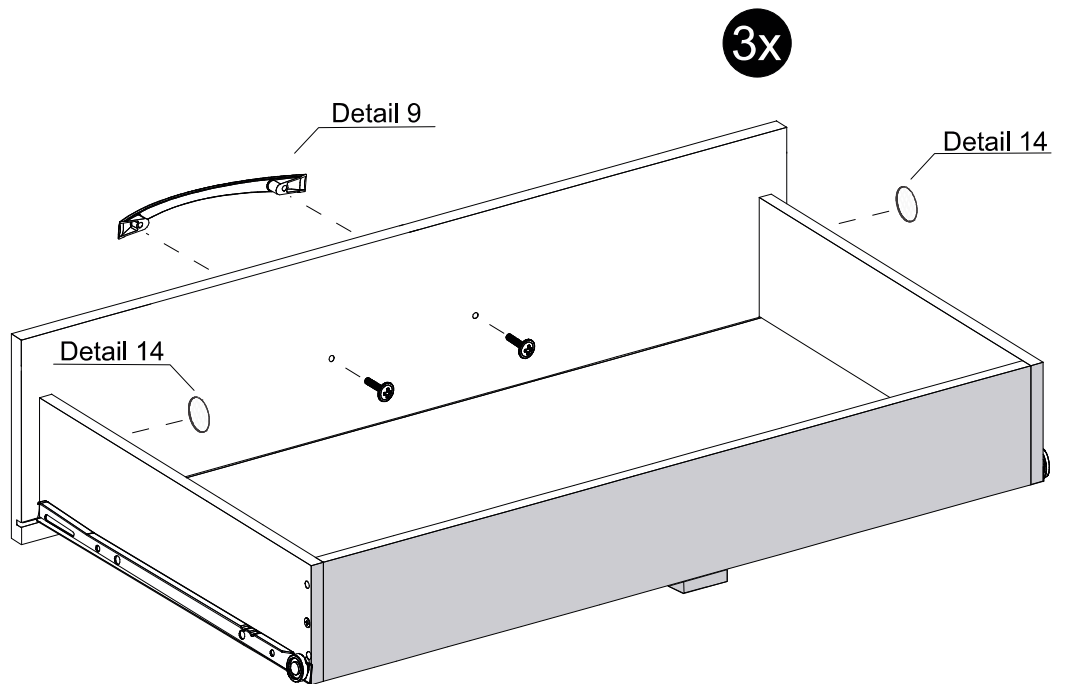
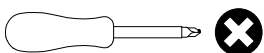

Detail 14

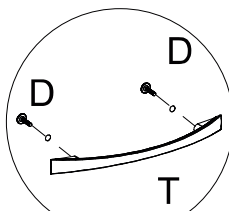

Detail 9

STEP 21

PARTS REQUIRED

6 - DRAWER SIDE x6

7 - DRAWER BACK PANEL x3

HARDWARE REQUIRED

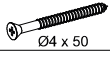
F  04
Ø4 x 50

TOOLS REQUIRED

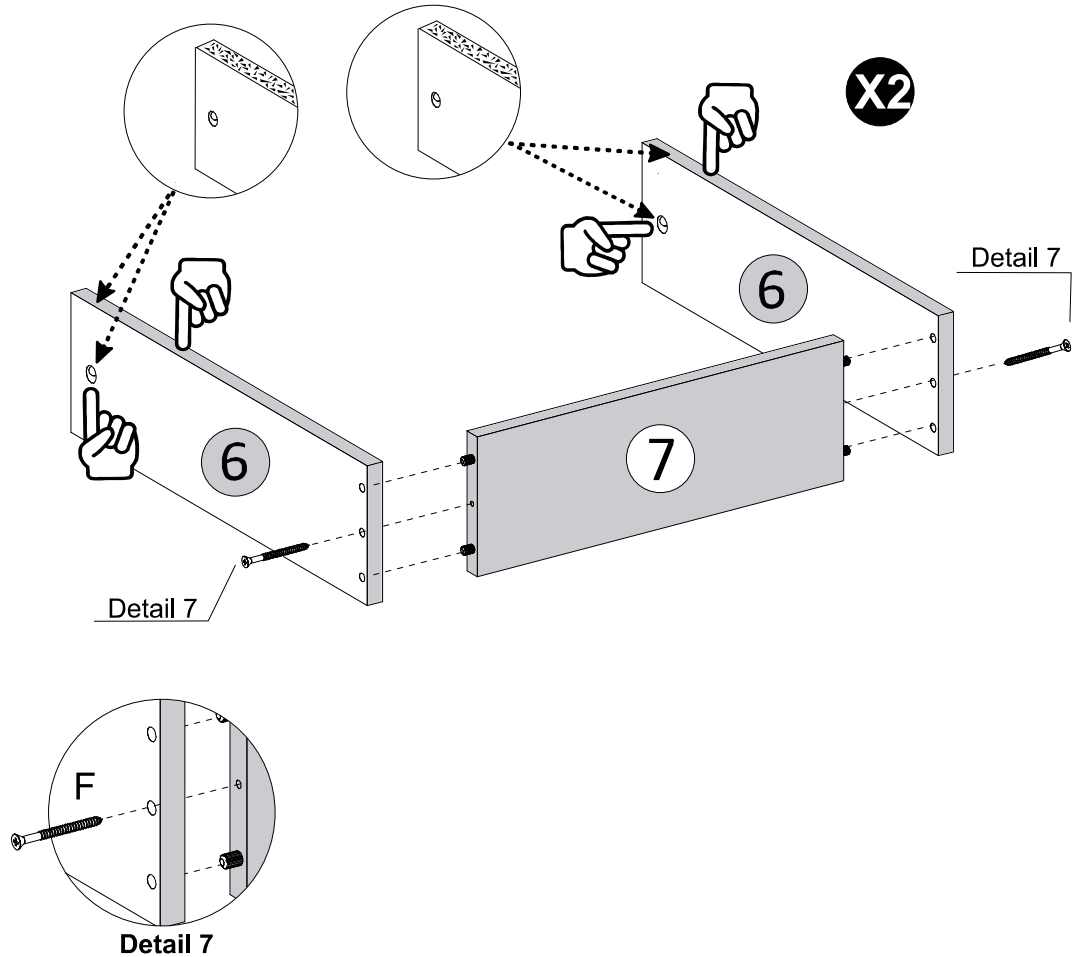
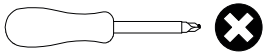

STEP 22

PARTS REQUIRED

5 - SMALL DRAWER FRONT x3

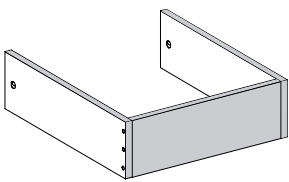

HARDWARE REQUIRED

J  04

P  01
GLUE

TOOLS REQUIRED

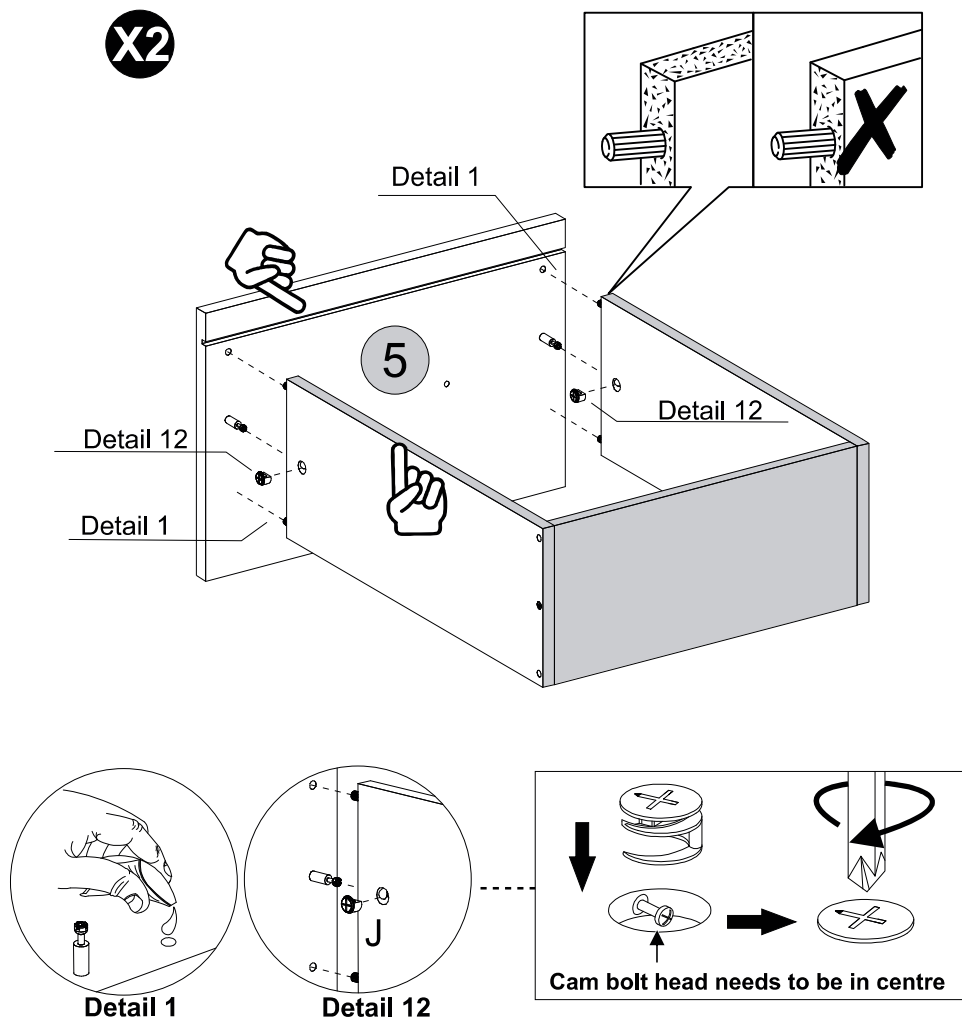
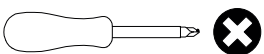

STEP 23

PARTS REQUIRED

8 - DRAWER BOTTOM x2

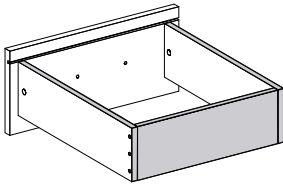

HARDWARE REQUIRED

H 10 x 10 08

TOOLS REQUIRED

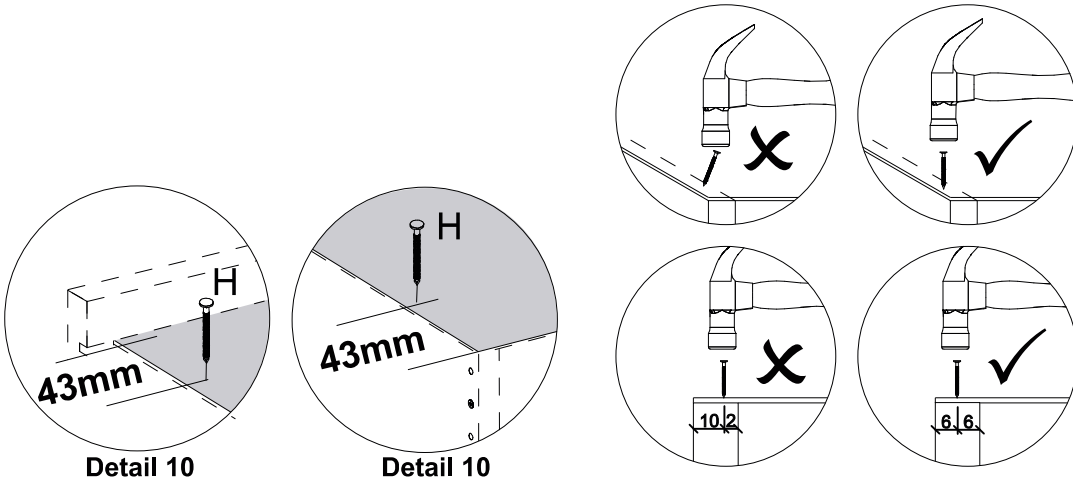
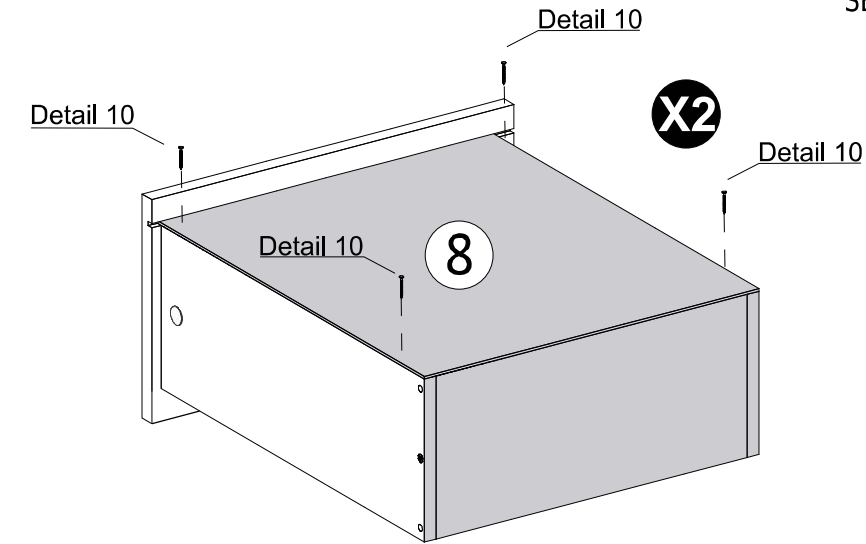
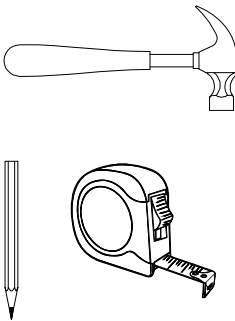

STEP 24

PARTS REQUIRED

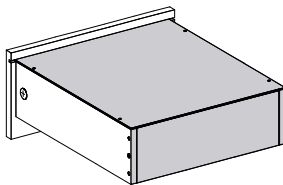

HARDWARE REQUIRED

H 10 x 10 08

TOOLS REQUIRED

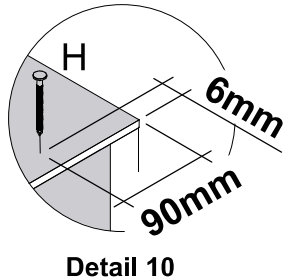
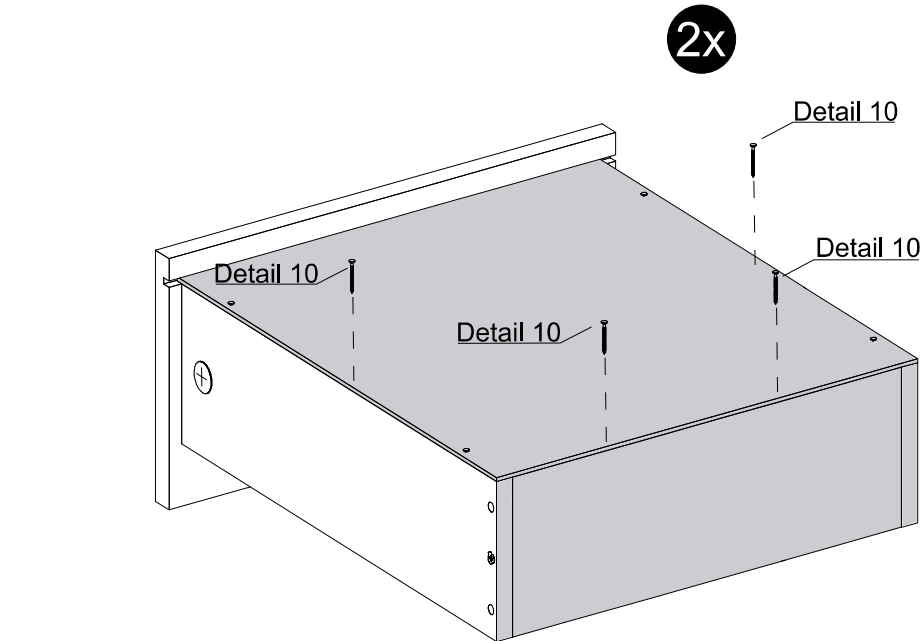
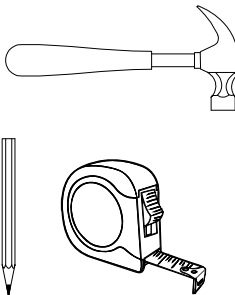

STEP 25

PARTS REQUIRED

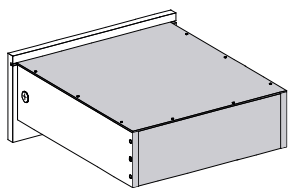

HARDWARE REQUIRED

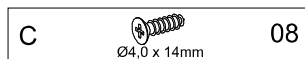

TOOLS REQUIRED

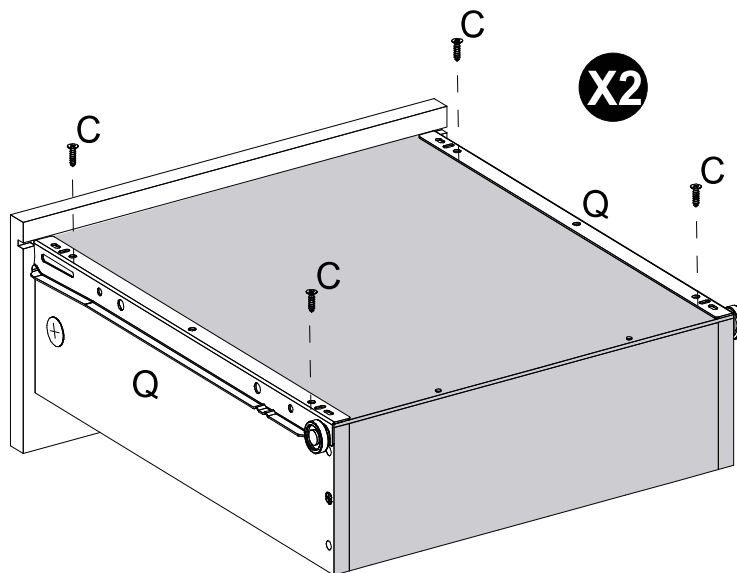
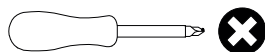

STEP 26

PARTS REQUIRED

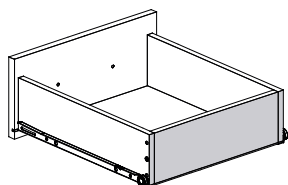

HARDWARE REQUIRED

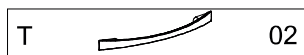
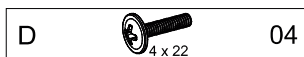

TOOLS REQUIRED

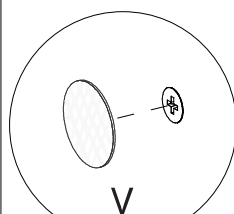
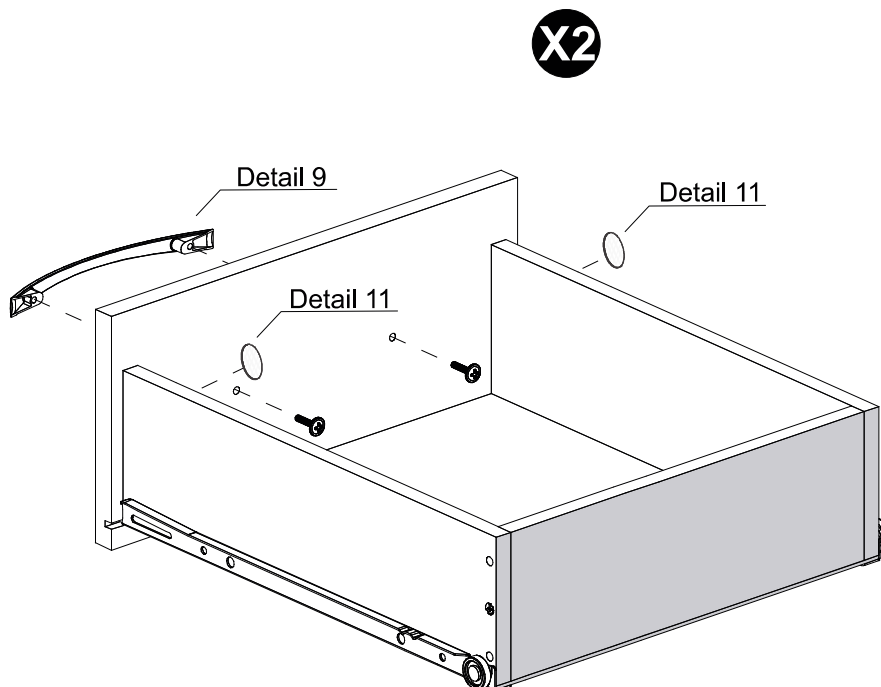
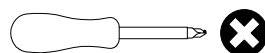

Detail 11

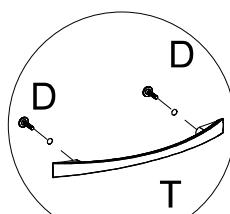

Detail 9

STEP 27

PARTS REQUIRED

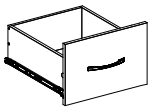
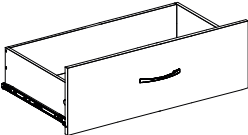
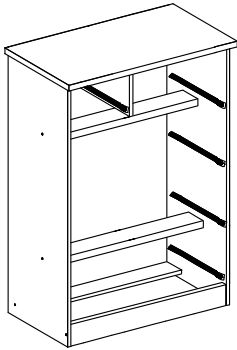

HARDWARE REQUIRED



TOOLS REQUIRED

See the last page

See the last page

Detail 14

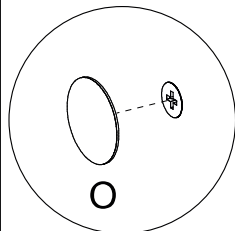

Detail 14

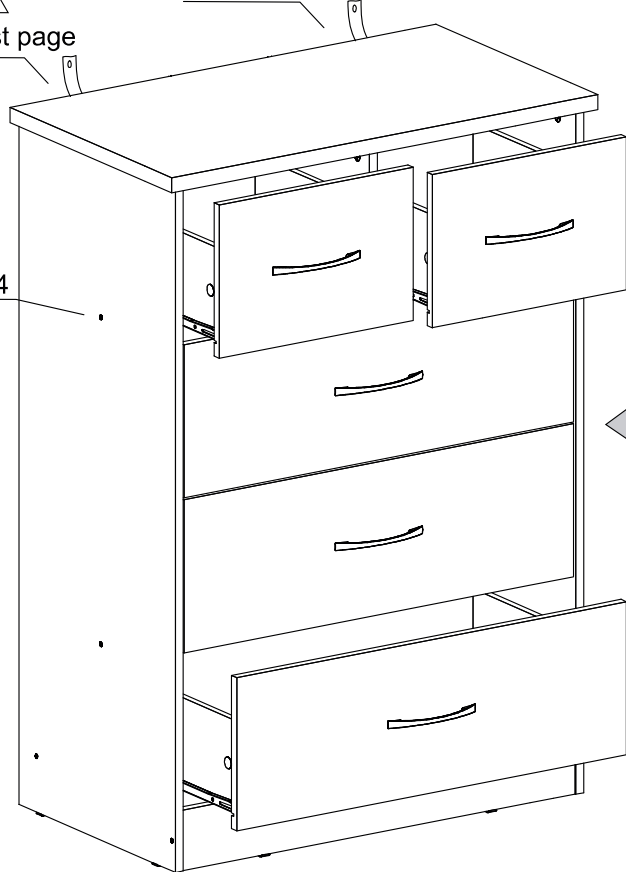

STEP 28

PARTS REQUIRED

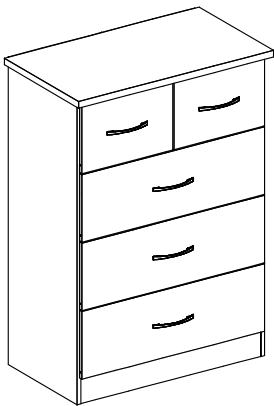

HARDWARE REQUIRED

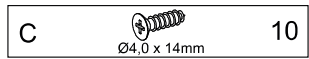

TOOLS REQUIRED

Detail 15

Detail 15

Detail 15

Detail 15

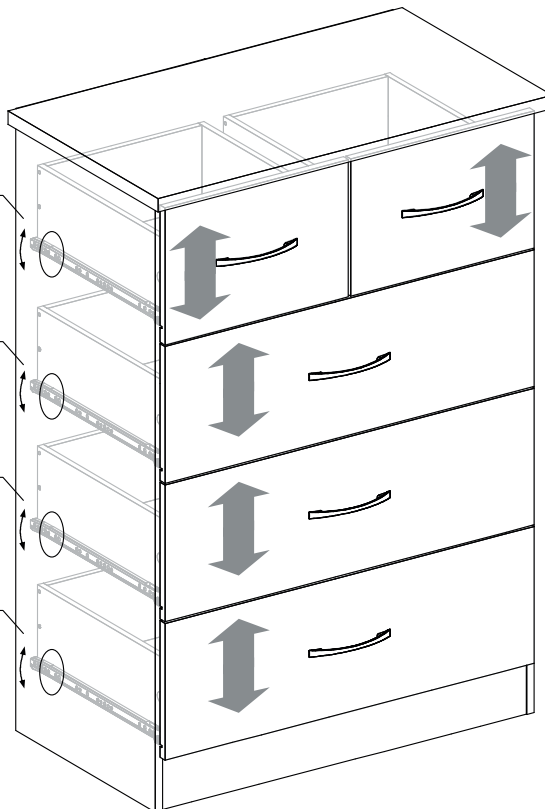

TIP
If desired, after assembly use an alcohol cleaner to erase the number printed on the parts.

Drawer Adjustment

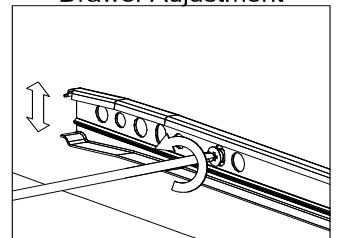

Right Side

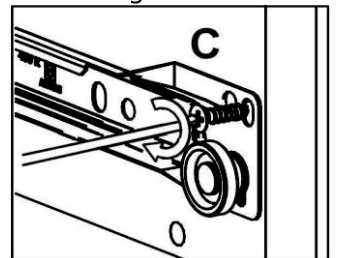

Left Side

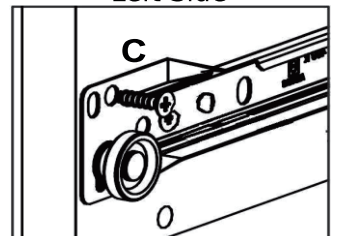

Detail 15

WARNING

Serious or fatal injuries can occur from furniture tipping over. To prevent the furniture from tipping over we recommend that it is permanently fixed to the wall.

Wall fixings are not supplied with this product as different wall materials require different types of fixing devices.
Please make sure you use fixings suitable for the walls in your home.

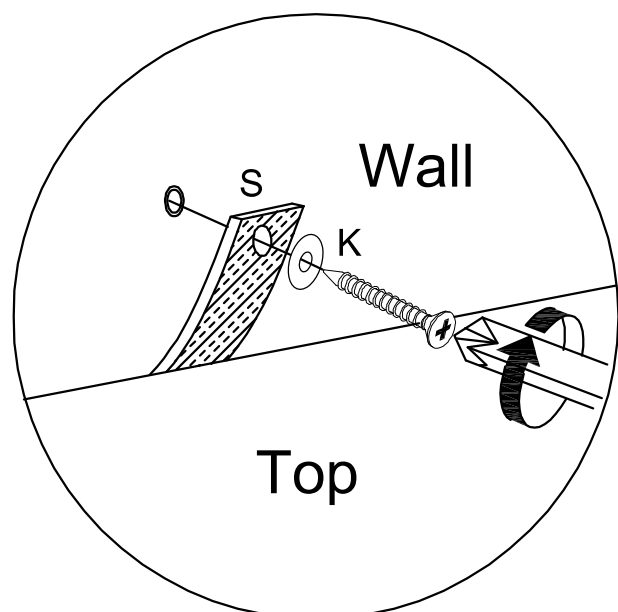
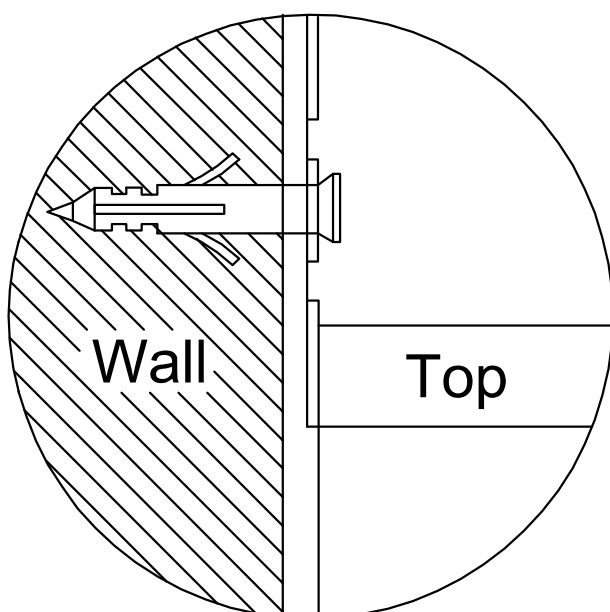
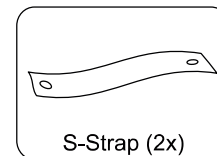
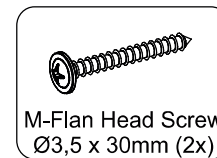
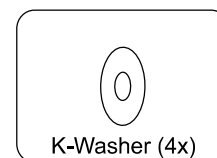
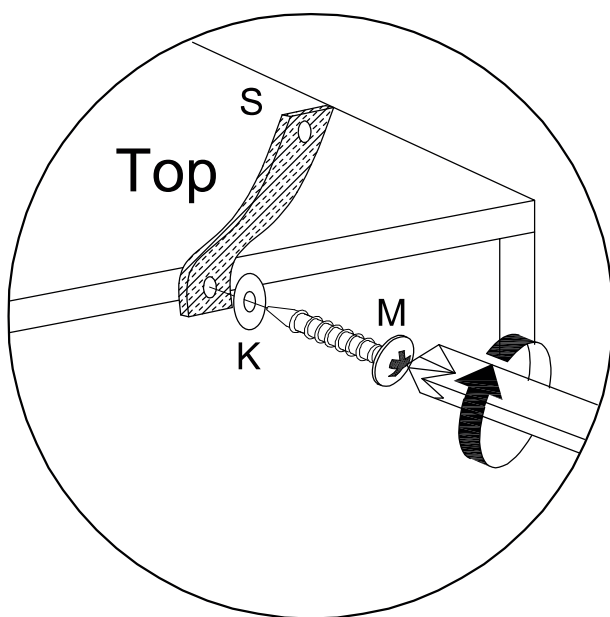

NEVADA 3 DRAWER BEDSIDE ASSEMBLY INSTRUCTIONS BLACK GLOSS

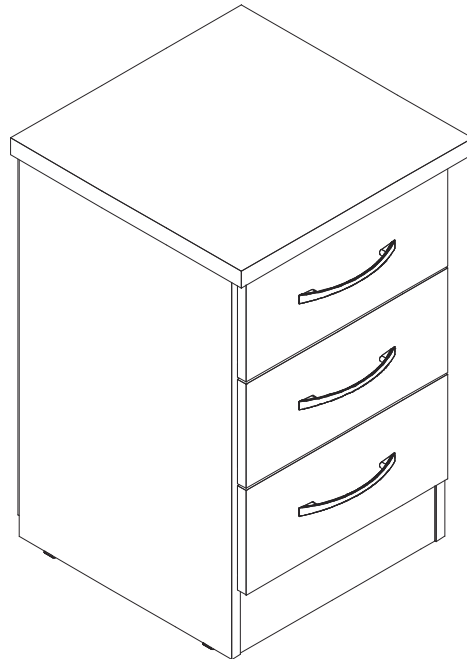

IMPORTANT FOR DOMESTIC USE ONLY

PLEASE READ BEFORE YOU CONTINUE FURTHER

CARE AND MAINTENANCE

- After unpacking this product please keep the original packaging in case it needs to be returned for any reason.
- Please ensure all fittings and parts are present before commencing with assembly.
 - Never drag or push products as this could cause damage to the joints making it inferior.
 - We strongly recommend that you keep children away from your work area.
 - We recommend that you lay a blanket or sheet on the floor to avoid damage to both your floor and the product.
 - Assemble this product as close to its final position as possible.
 - Do not place this product next to a radiator or in direct sunlight.
 - Do not drag or push items across your high gloss furniture as this may cause the surface to scratch
 - Wood is a natural product and may expand if subjected to damp and may shrink or crack if subjected to heat. Therefore it is recommended that room temperature is maintained, with no sudden temperature fluctuations.
 - Make sure any spillage is wiped off immediately.
 - Do not place hot or chilled items directly on to the surface, use a place mat or marking will occur.
 - For general cleaning use a soft cotton or micro fibre cloth, and do not use detergents of any kind.
 - From time to time it may be necessary to tighten fittings, regular inspections should be carried out.
 - Do not place on a wet or damp floor as staining may occur to your floor.

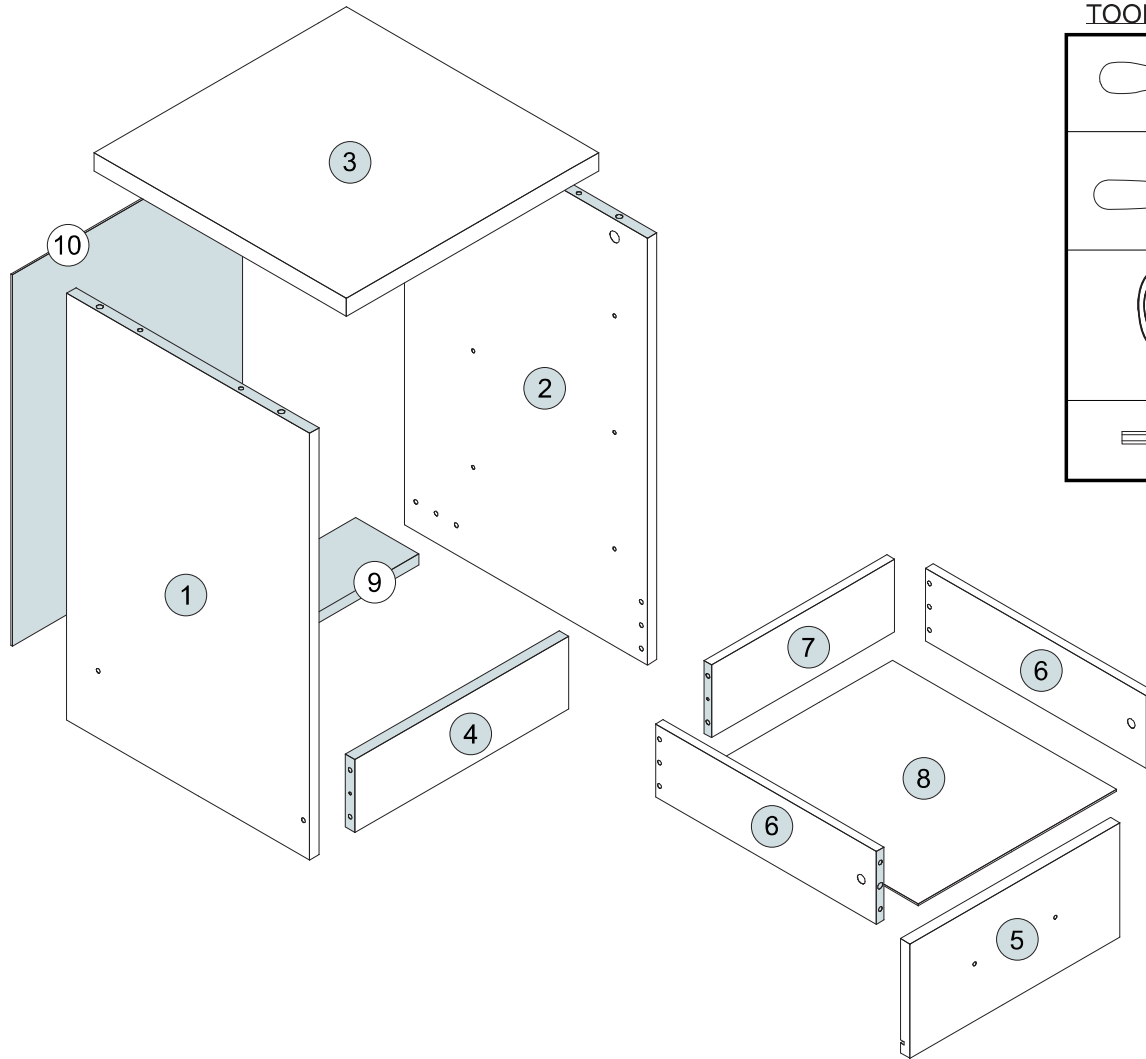

TOOLS REQUIRED

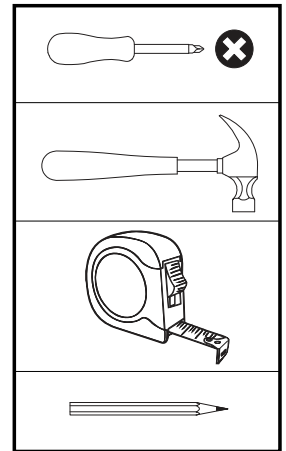









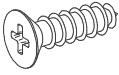
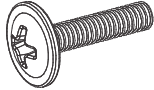

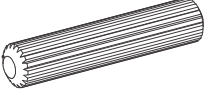

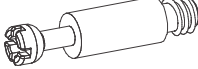
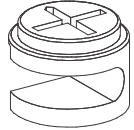
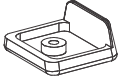
PARTS LIST

Please Note:
The below parts have all been stamped with the part number to help identify them during assembly.

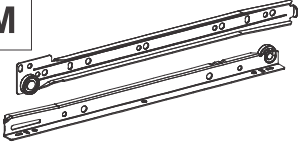
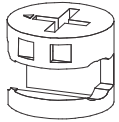
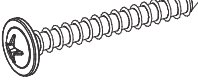
Part Number	Part Code	Part Description	Quantity	Carton
01	S100-103-089-HV1-01	Left Side Panel	1	1/1
02	S100-103-089-HV1-02	Right Side Panel	1	1/1
03	S100-103-089-HV1-03	Top Panel	1	1/1
04	S100-103-089-HV1-04	Front Baseboard	1	1/1
05	S100-103-089-HV1-05	Drawer Front	3	1/1
06	S100-103-089-HV1-06	Drawer Side	6	1/1
07	S100-103-089-HV1-07	Drawer Back Panel	3	1/1
08	S100-103-089-HV1-08	Drawer Bottom	3	1/1
09	S100-103-089-HV1-09	Back Baseboard	1	1/1
10	S100-103-089-HV1-10	Back Panel	1	1/1

FITTINGS LIST

<p>A</p>  <p>Flat Head Screw 2/+ Ø6,0 x 10mm (12x)</p>	<p>B</p>  <p>Flat Head Screw 2/+ Ø4,0 x 14mm (18x)</p>	<p>C</p>  <p>Flan Head Screw Ø4,0 x 20mm (6x)</p>	<p>D</p>  <p>Flat Head Screw 1/+ Ø4,0 x 50mm (10x)</p>
<p>E</p>  <p>2/+ Dowel Ø6,0 x 30mm (36x)</p>	<p>F</p>  <p>2/+ Nail 10x10 Ringed-1,5x23mm (42x)</p>	<p>G</p>  <p>2/+ Cam Bolt (10x)</p>	<p>H</p>  <p>1/+ Cam Nut Ø12x8 8mm (6x)</p>
<p>I</p>  <p>1/+ Plastic Foot L 19x17x8mm Ø2 (4x)</p>	<p>J</p>  <p>2/+ Hole Plugs 19mm (4x)</p>	<p>K</p>  <p>GLUE Glue 10 Gr (2x)</p>	<p>L</p>  <p>Handle (3x)</p>
<p>M</p>  <p>Drawer Runners 350mm (3x)</p>	<p>N</p>  <p>1/+ Cam Nut Ø14,9x11 mm (4x)</p>	<p>O</p>  <p>Flan Head Screw 1/+ Ø3,5 x 30mm (1x)</p>	<p>P</p>  <p>Strap 200x20x1MM (1x)</p>
<p>Q</p>  <p>1/+ Washer Ø16x7 (2x)</p>	<p>R</p>  <p>+1/2 Hole Plugs Lineo 19mm (6x)</p>		

TIPS FOR FITTINGS CAM-LOCKS

WHEN FITTING CAM NUT. ENSURE STARTING POSITION IS CORRECT BEFORE YOU INSERT CONNECTING CAM BOLT TURN CLOCKWISE UNTIL SECURE



✓



↑

CORRECT



✗



↑

WRONG

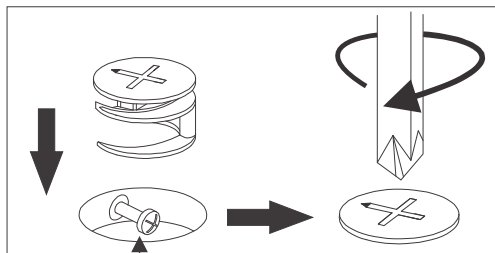

Cam bolt head needs to be in centre

CAMBOLT

Tighten until shoulder is flush with panel. Do not overtighten or undertighten (see example below)

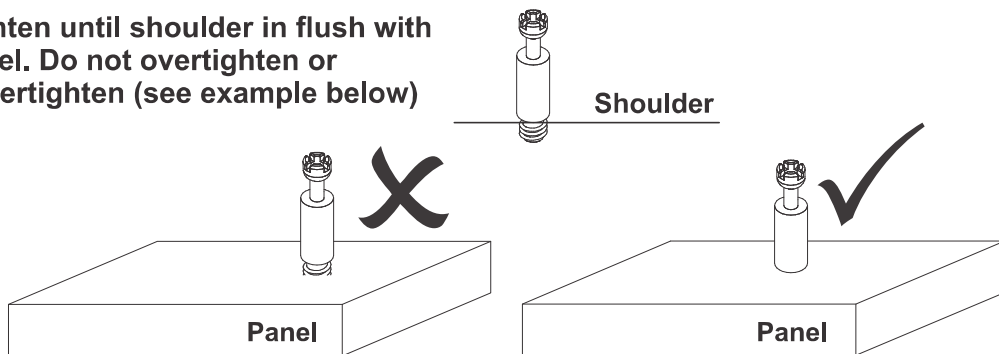



STEP 1

PARTS REQUIRED

1 - LEFT SIDE PANEL x1

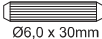
HARDWARE REQUIRED

E  02
Ø6,0 x 30mm

F  02
10 x 10

I  02

K  01
GLUE

TOOLS REQUIRED

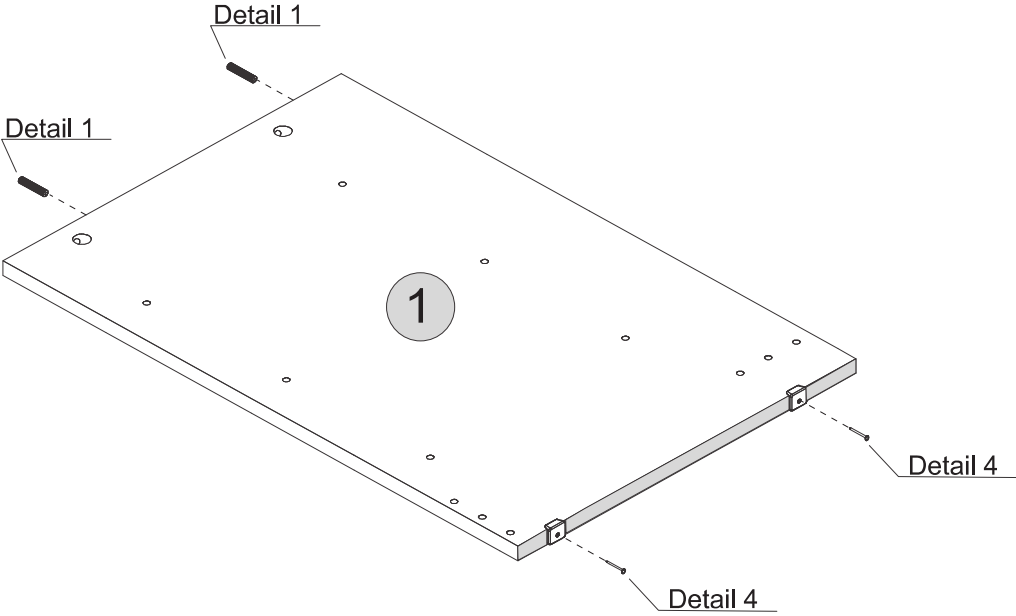
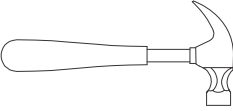

Detail 1

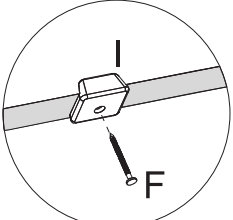

Detail 4

STEP 2

PARTS REQUIRED

2 - RIGHT SIDE PANEL x1

HARDWARE REQUIRED

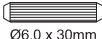
E  02
Ø6,0 x 30mm

F  02
10 x 10

I  02

K  01
GLUE

TOOLS REQUIRED

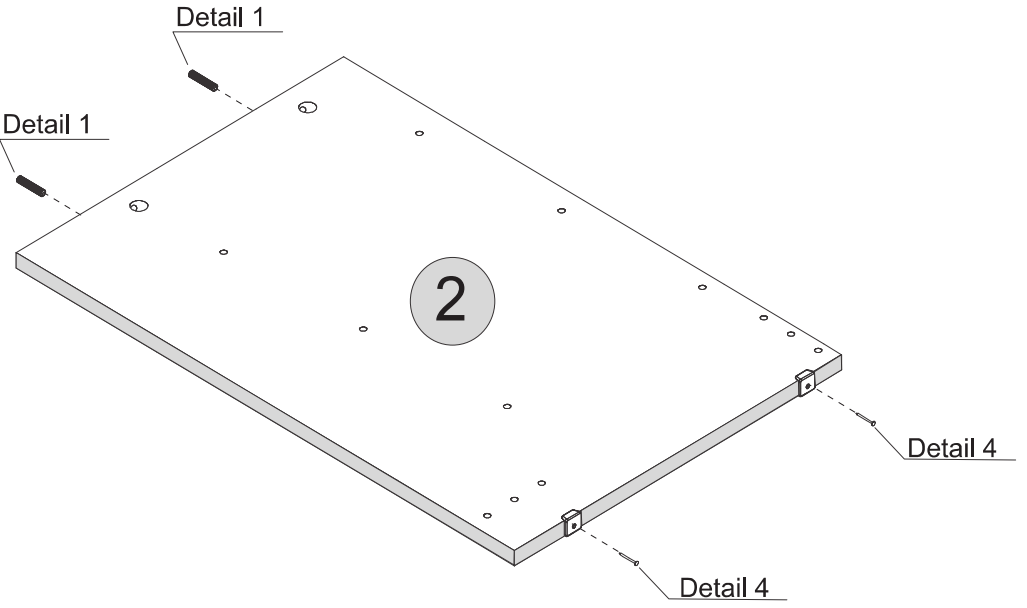
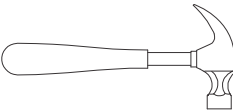

Detail 1

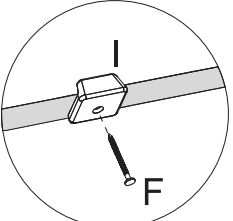

Detail 4

STEP 3

PARTS REQUIRED

2 - RIGHT SIDE PANEL x1

HARDWARE REQUIRED

A  06
Ø6.0 x 10mm

B  03
Ø4.0 x 14mm

M  03
RIGHT

TOOLS REQUIRED

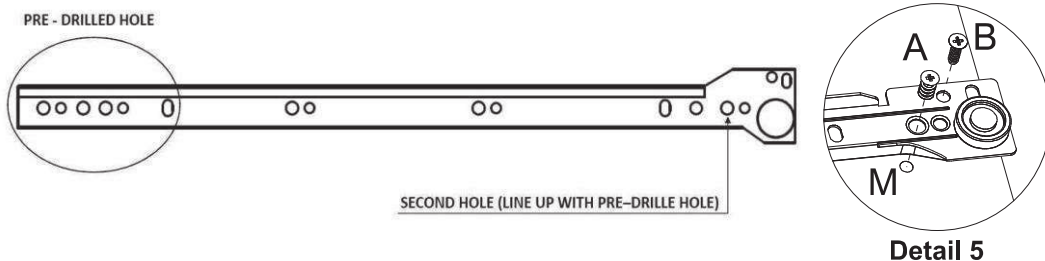
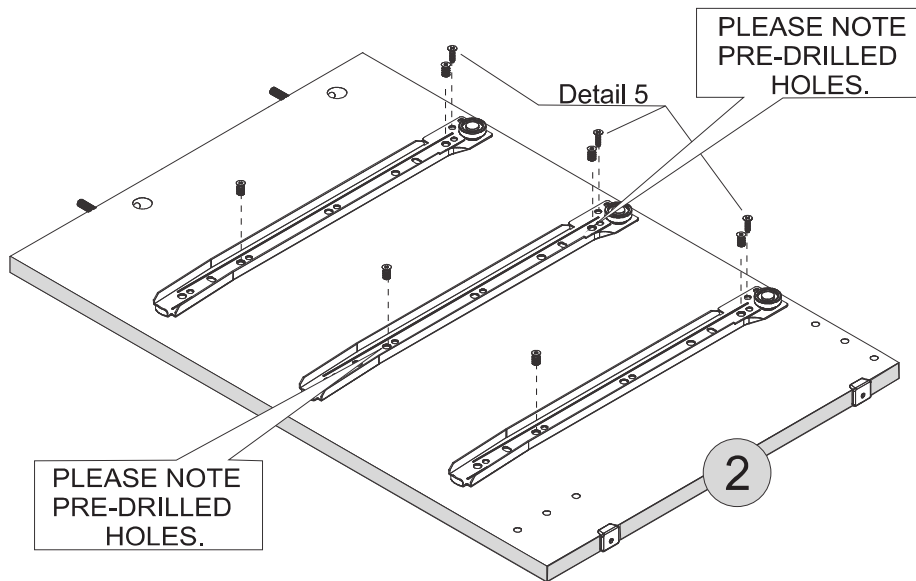
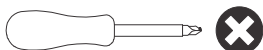

STEP 4

PARTS REQUIRED

1 - LEFT SIDE PANEL x1

HARDWARE REQUIRED

A  06
Ø6.0 x 10mm

B  03
Ø4.0 x 14mm

M  03
LEFT

TOOLS REQUIRED

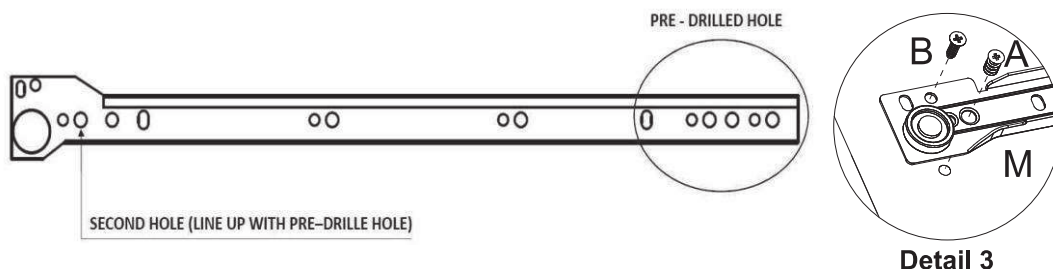
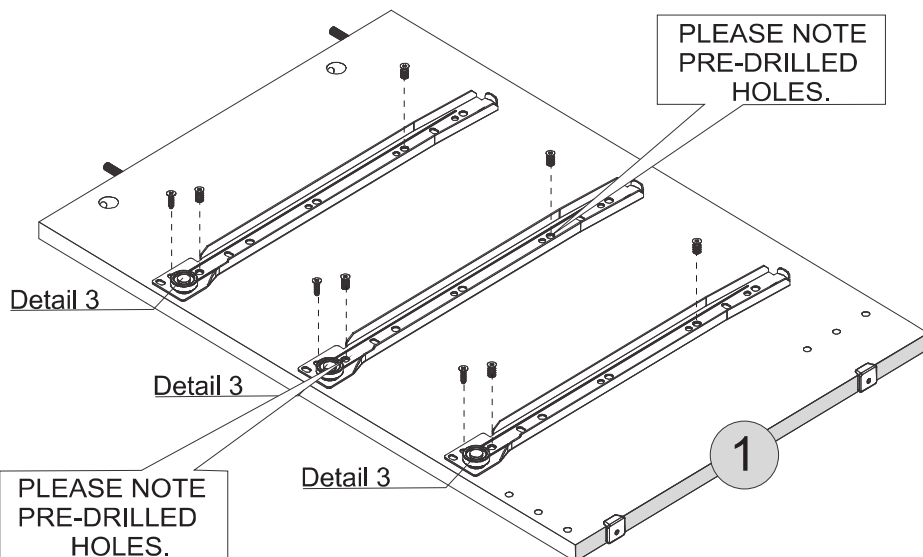
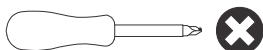

STEP 5

PARTS REQUIRED

9 - BACK BASEBOARD x1

4 - FRONT BASEBOARD x1

HARDWARE REQUIRED

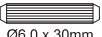
E  08
Ø6,0 x 30mm

K  01
GLUE

TOOLS REQUIRED

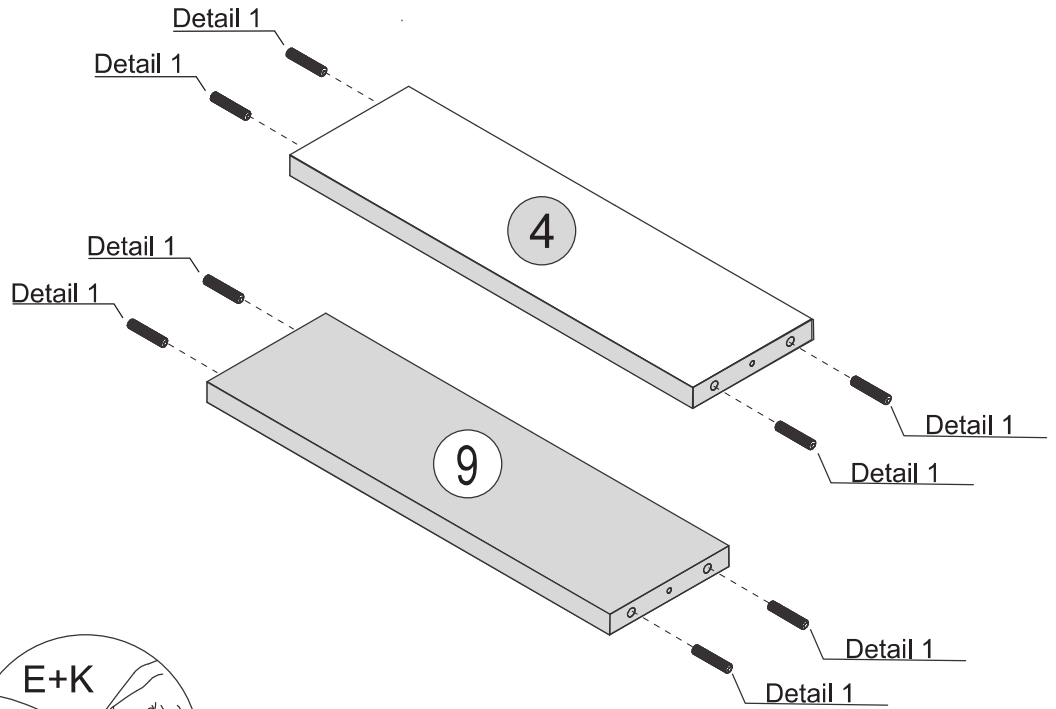

STEP 6

PARTS REQUIRED

2 - RIGHT SIDE PANEL x1

9 - BACK BASEBOARD x1

4 - FRONT BASEBOARD x1

HARDWARE REQUIRED

D  02
Ø4 x 50mm

K  01
GLUE

TOOLS REQUIRED

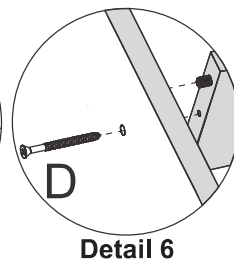
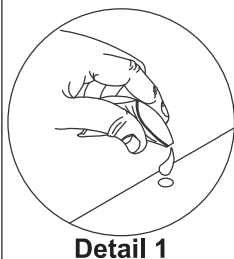
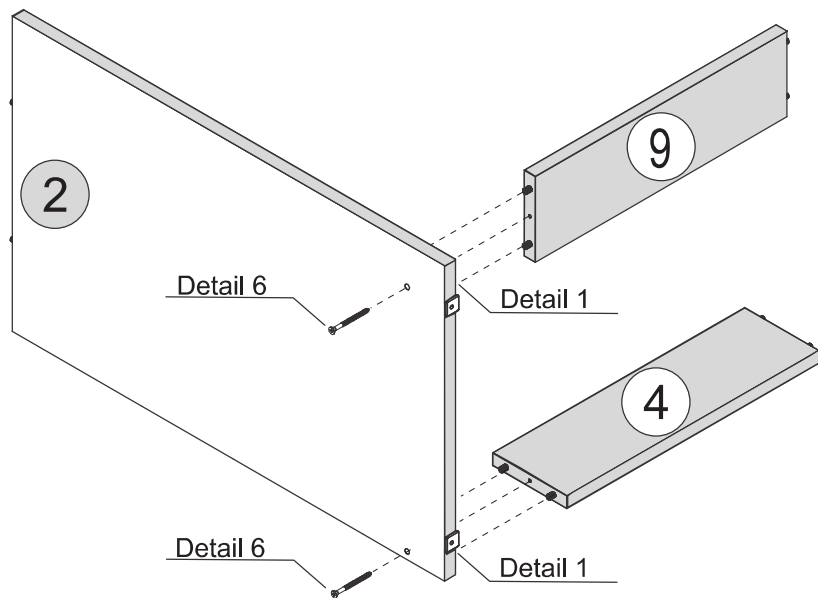
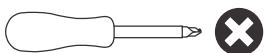

STEP 7

PARTS REQUIRED

1 - LEFT SIDE PANEL x1

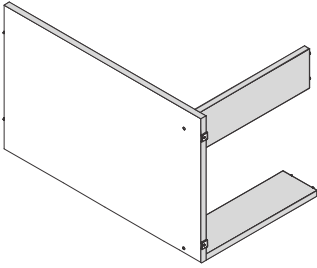

HARDWARE REQUIRED

D  02
Ø4 x 50mm

K  01
GLUE

TOOLS REQUIRED

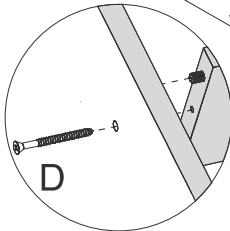
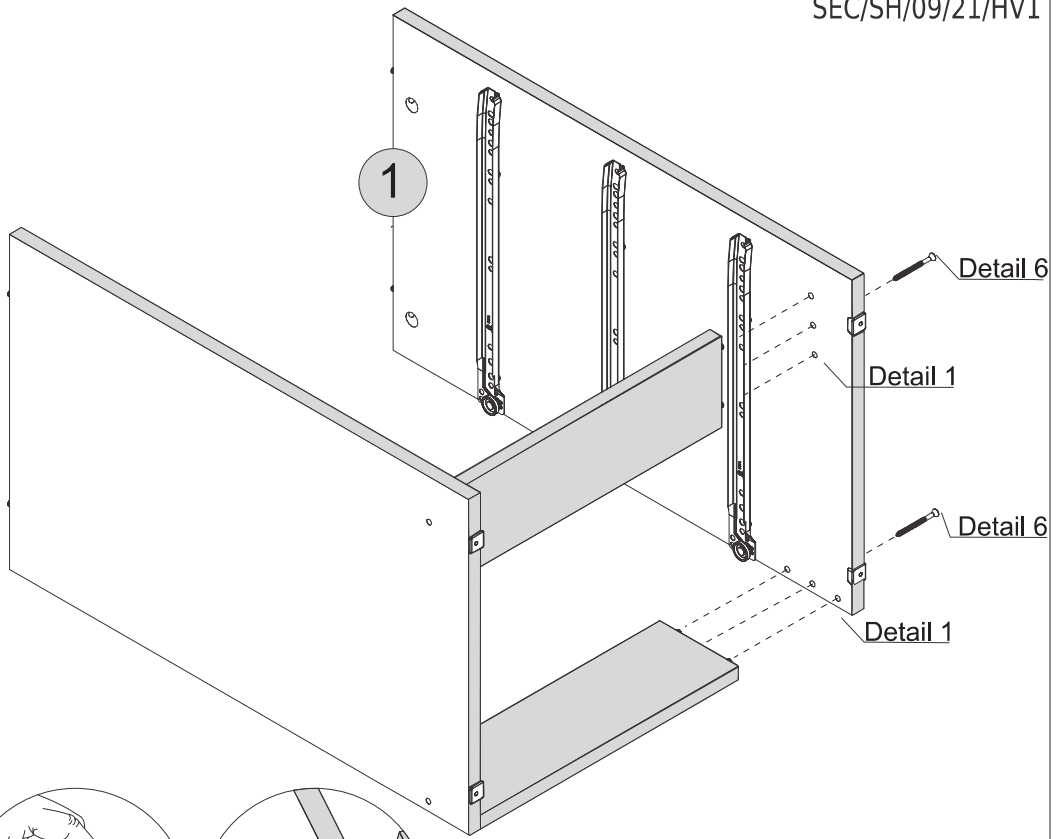
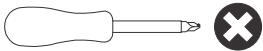

Detail 1

Detail 6

STEP 8

PARTS REQUIRED

3 - TOP PANEL x1

HARDWARE REQUIRED

G  04

TOOLS REQUIRED

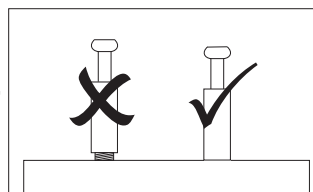
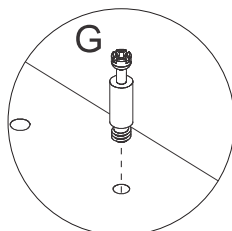
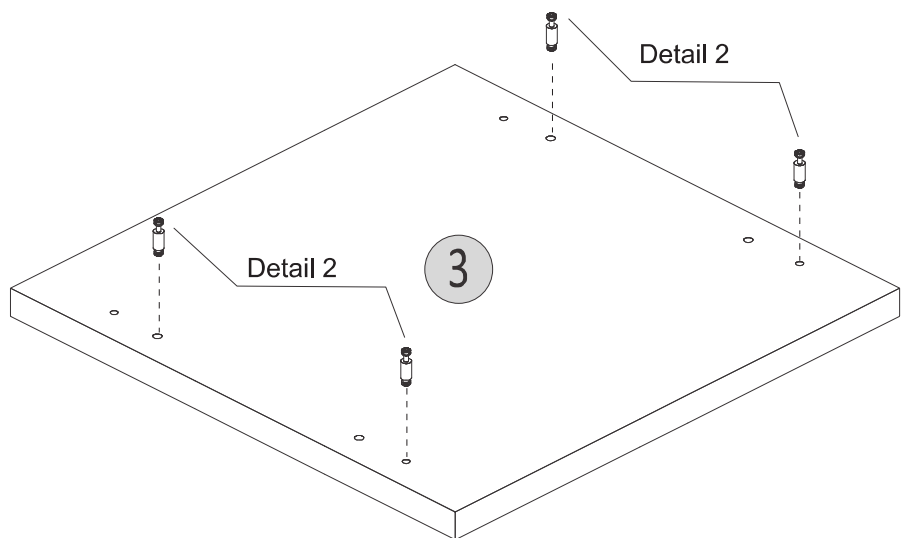
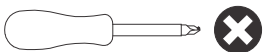

Detail 2

STEP 9

PARTS REQUIRED

3 - TOP PANEL x1

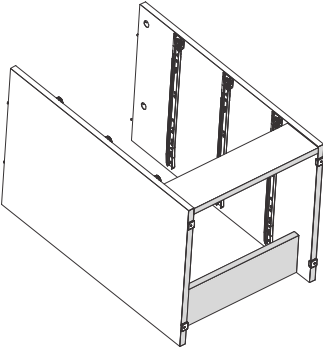

HARDWARE REQUIRED

K  01

N  04

TOOLS REQUIRED

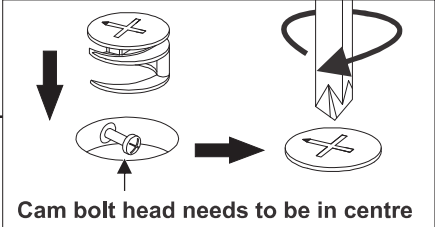
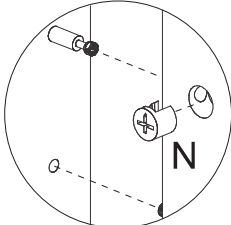
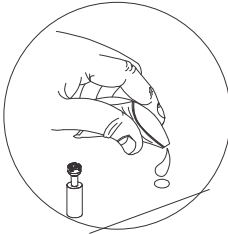
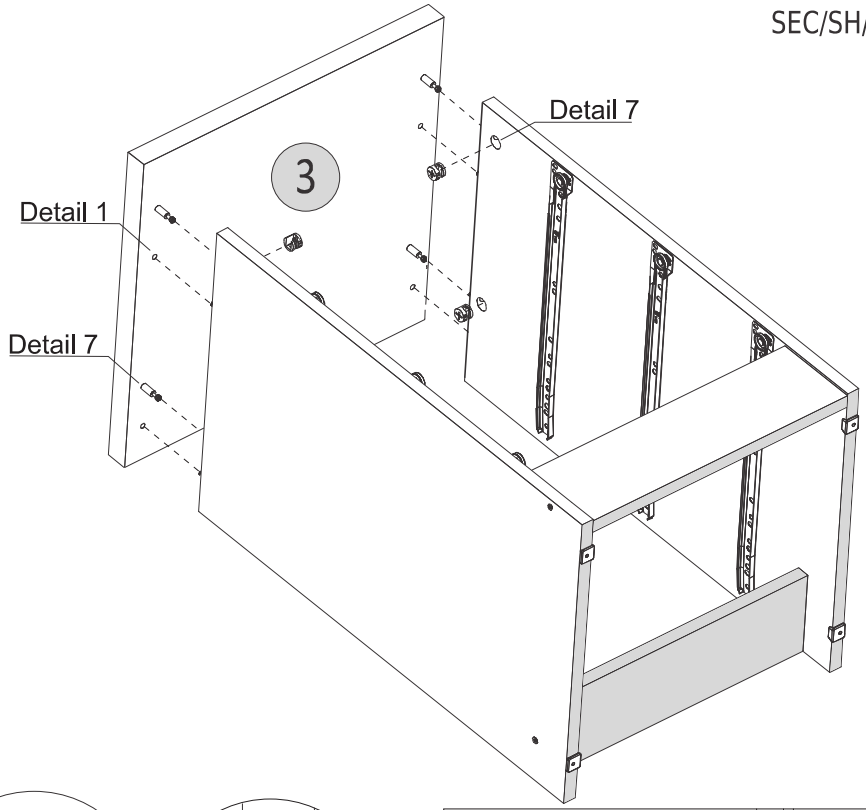
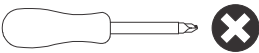

STEP 10

PARTS REQUIRED

10 - BACK PANEL x1

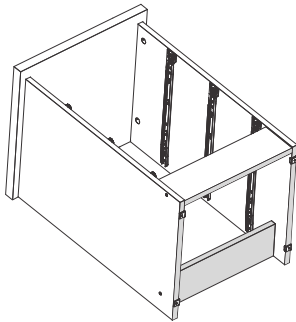

HARDWARE REQUIRED

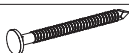
F  14

TOOLS REQUIRED

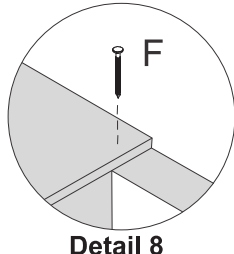
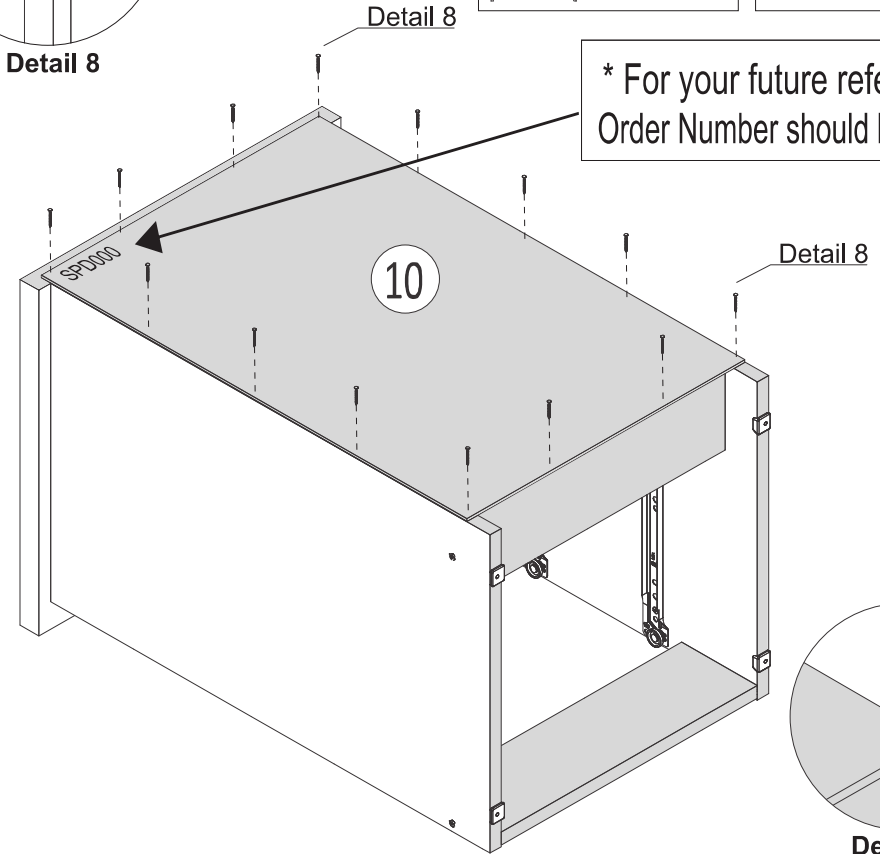
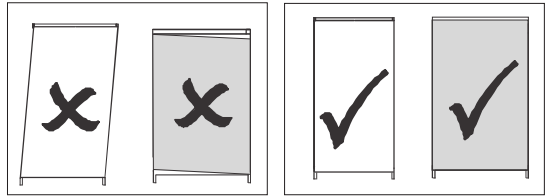
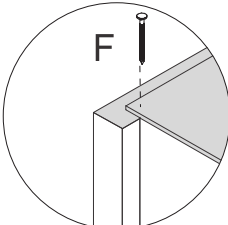
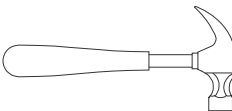

STEP 11

SEC/SH/09/21/HV1

PARTS REQUIRED

6 - DRAWER SIDE x6

7 - DRAWER BACK PANEL x3

HARDWARE REQUIRED

E  24
Ø6 x 30mm

K  01
GLUE

TOOLS REQUIRED

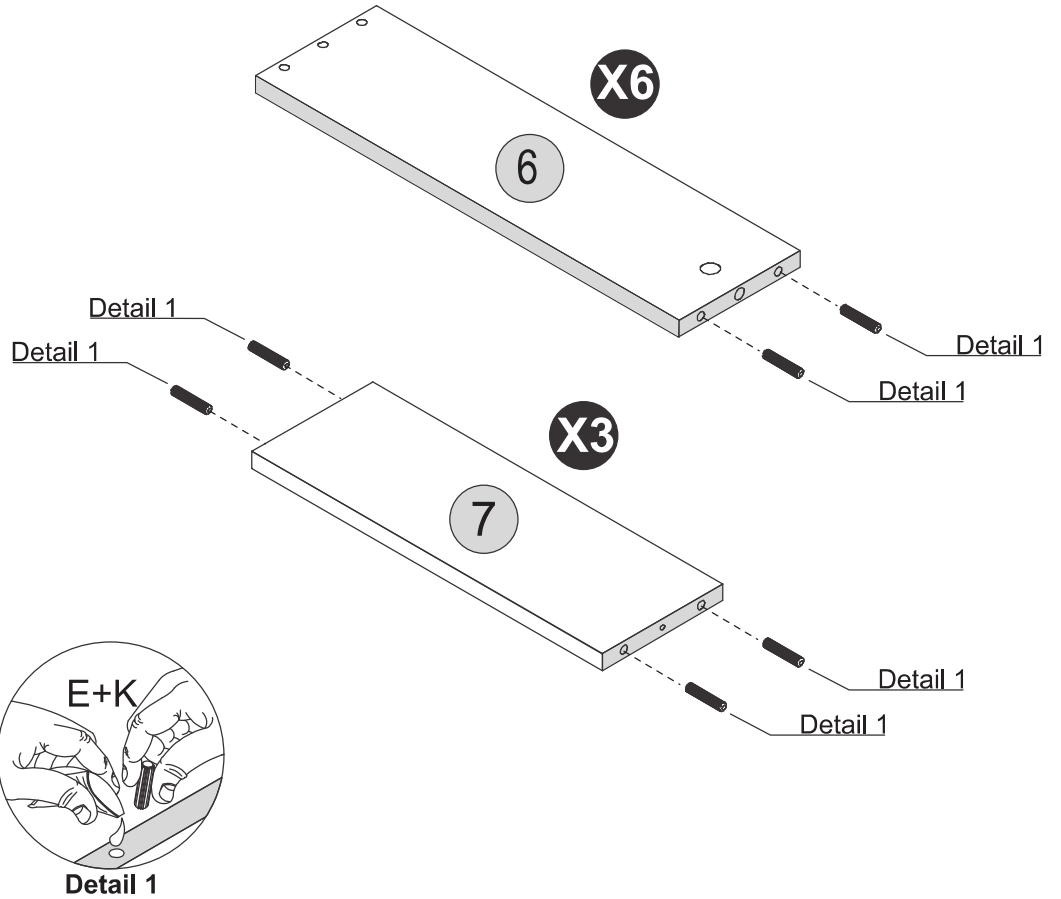

STEP 12

PARTS REQUIRED

5 - DRAWER FRONT x3

HARDWARE REQUIRED

G  06

TOOLS REQUIRED

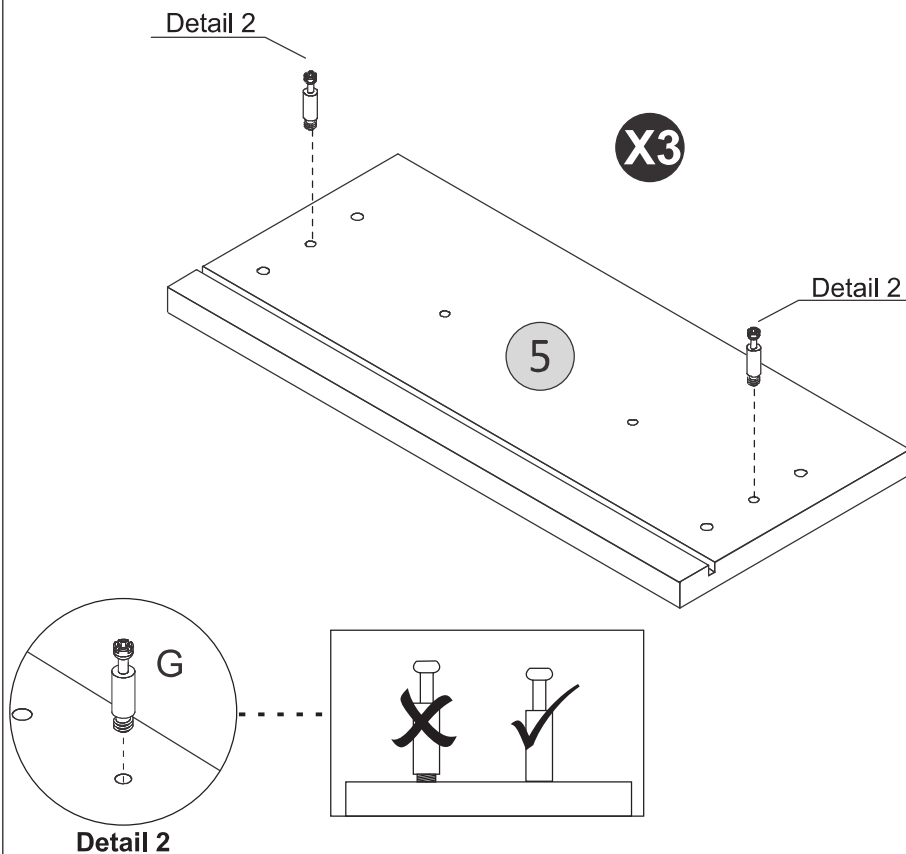
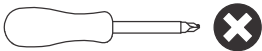

STEP 13

PARTS REQUIRED

6 - DRAWER SIDE x6

7 - DRAWER BACK PANEL x3

HARDWARE REQUIRED

D  06
Ø4 x 50mm

TOOLS REQUIRED

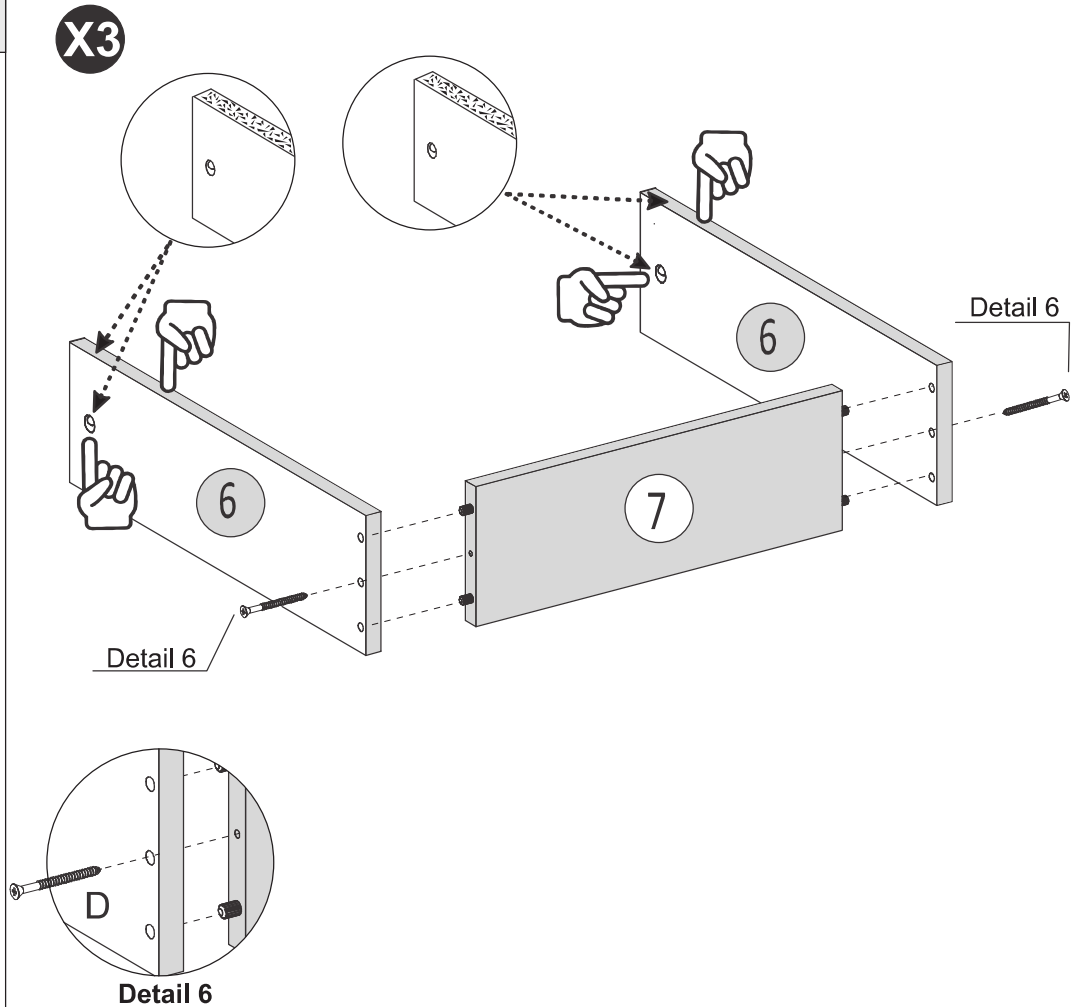

STEP 14

PARTS REQUIRED

5 - DRAWER FRONT x3

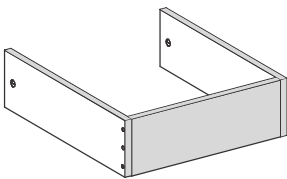

HARDWARE REQUIRED

H  06

K  01
GLUE

TOOLS REQUIRED

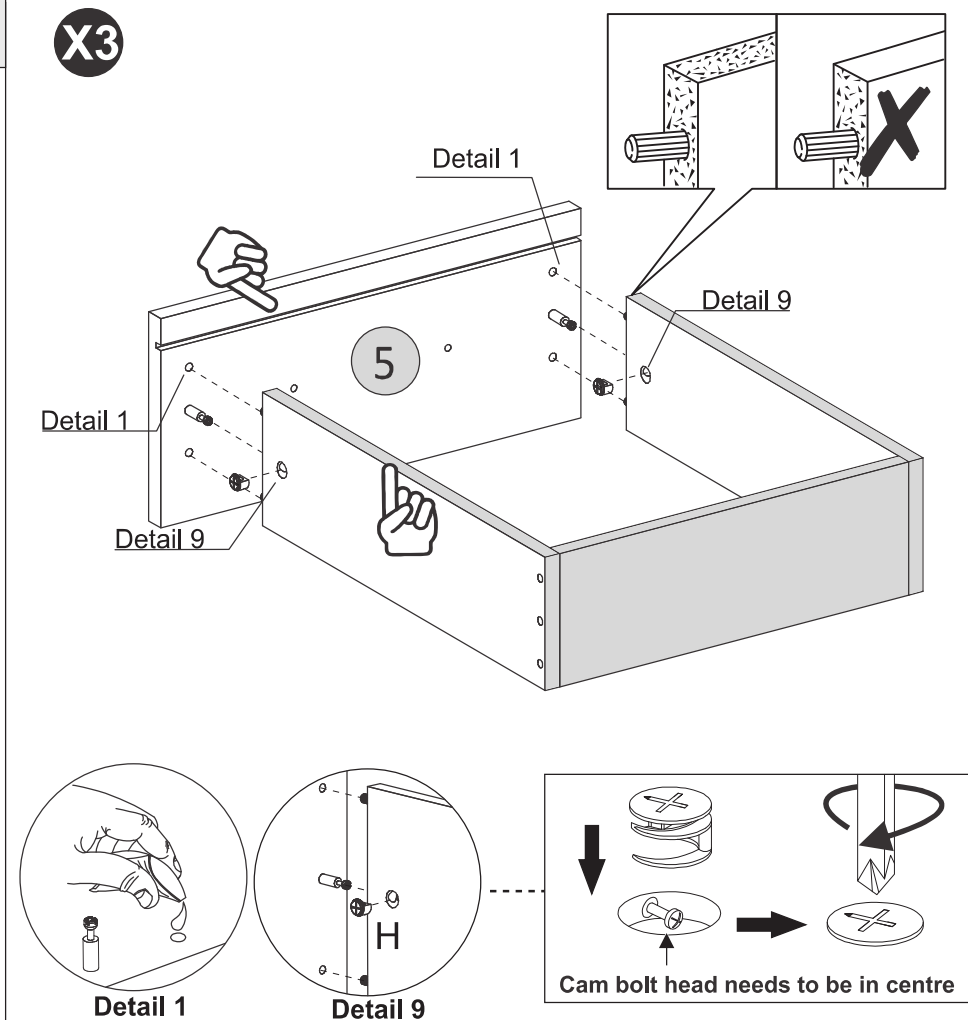
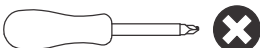

STEP 15

PARTS REQUIRED

8 - DRAWER BOTTOM x3

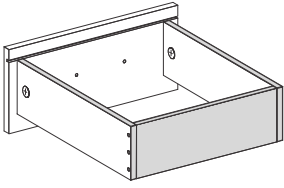

HARDWARE REQUIRED

F  12
10 x 10

TOOLS REQUIRED

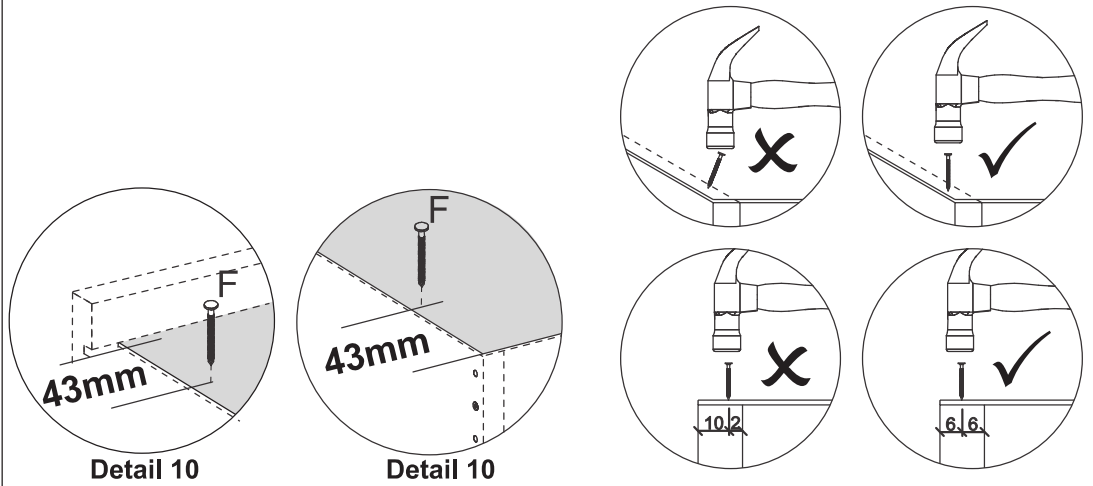
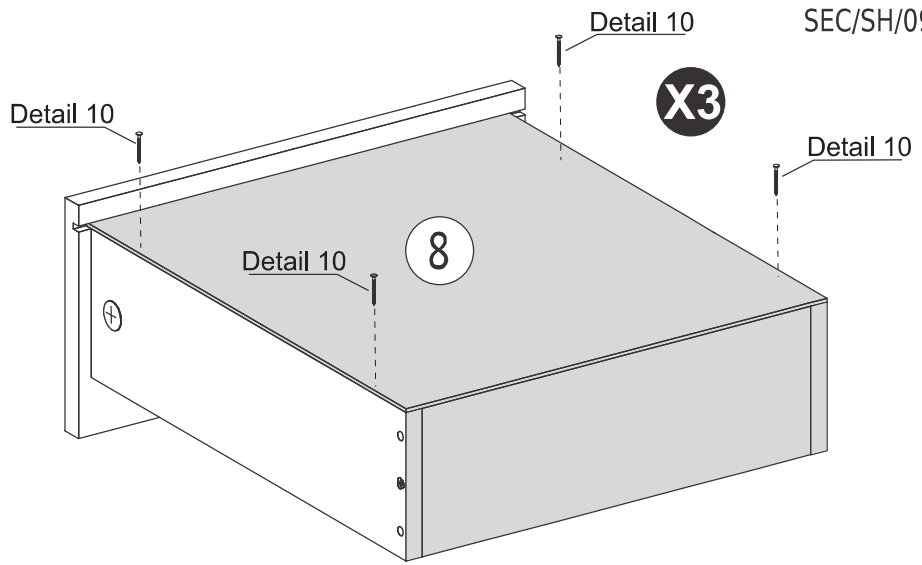
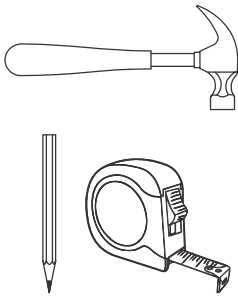

STEP 16

PARTS REQUIRED

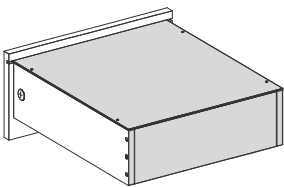

HARDWARE REQUIRED

F  12
10 x 10

TOOLS REQUIRED

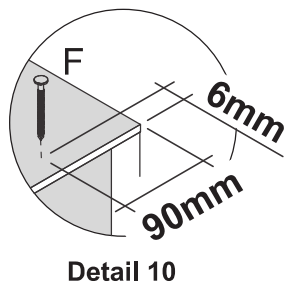
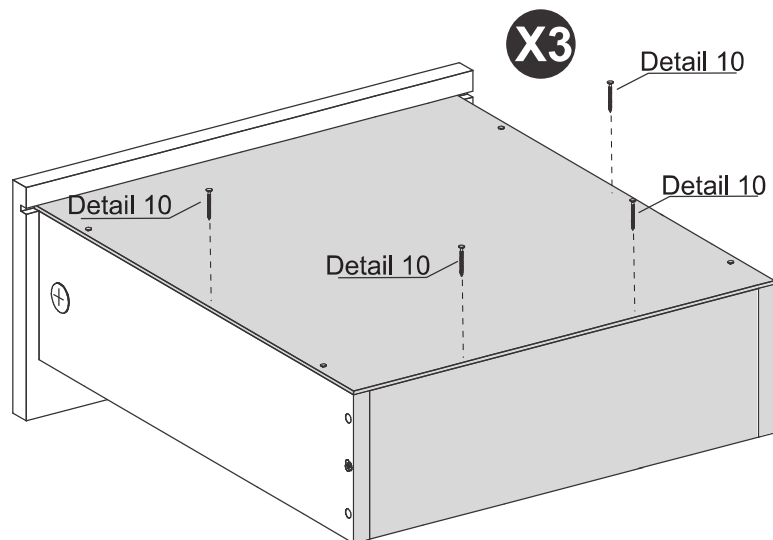
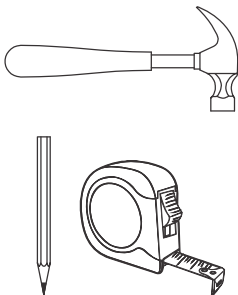

STEP 17

PARTS REQUIRED

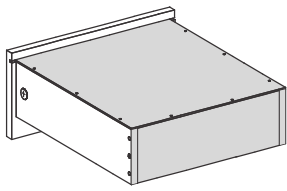

HARDWARE REQUIRED

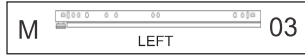
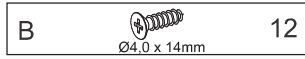

TOOLS REQUIRED

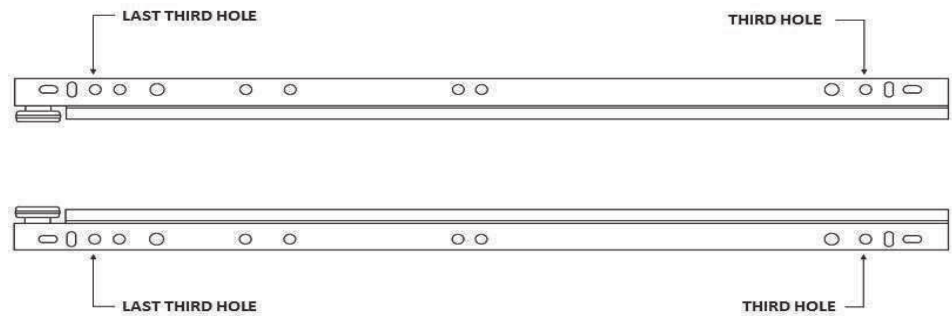
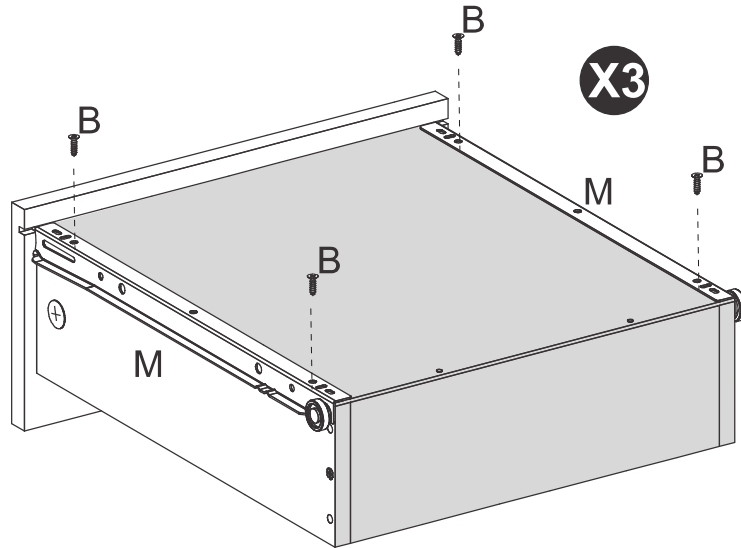
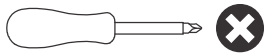

STEP 18

PARTS REQUIRED

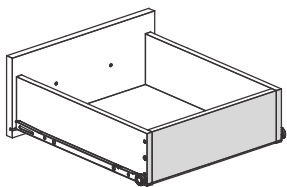

HARDWARE REQUIRED

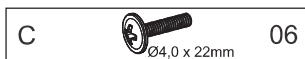

TOOLS REQUIRED

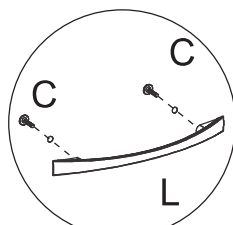
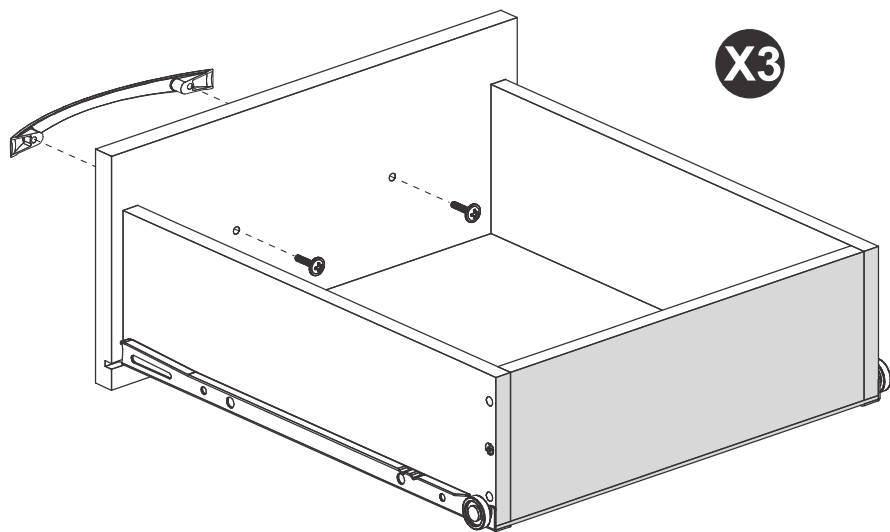
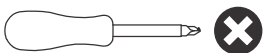

Detail 11

STEP 19

PARTS REQUIRED

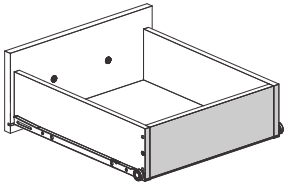

HARDWARE REQUIRED

R 06

TOOLS REQUIRED

X3

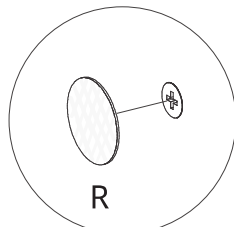
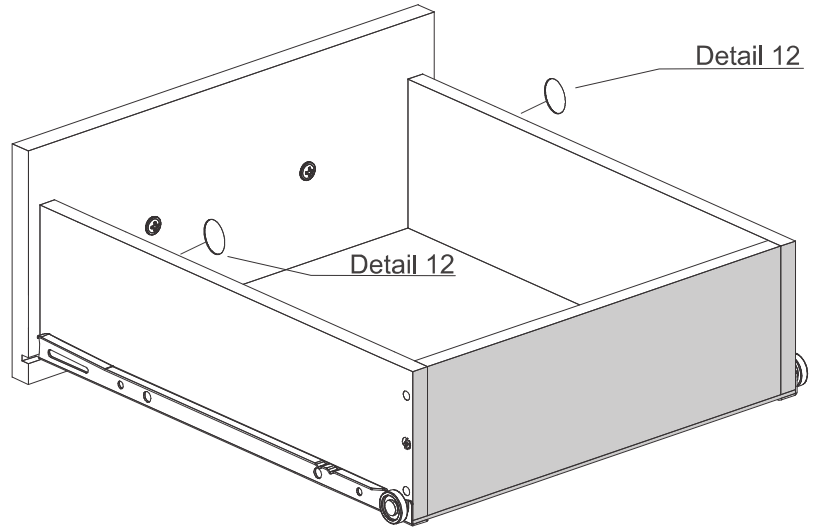

Detail 12

STEP 20

PARTS REQUIRED

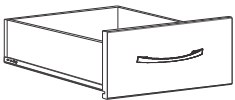

HARDWARE REQUIRED

J 04

TOOLS REQUIRED



See the last page

TIP

If desired, after assembly use an alcohol cleaner to erase the number printed on the parts.

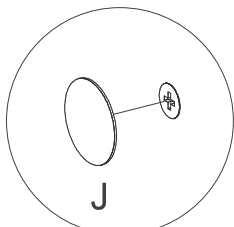
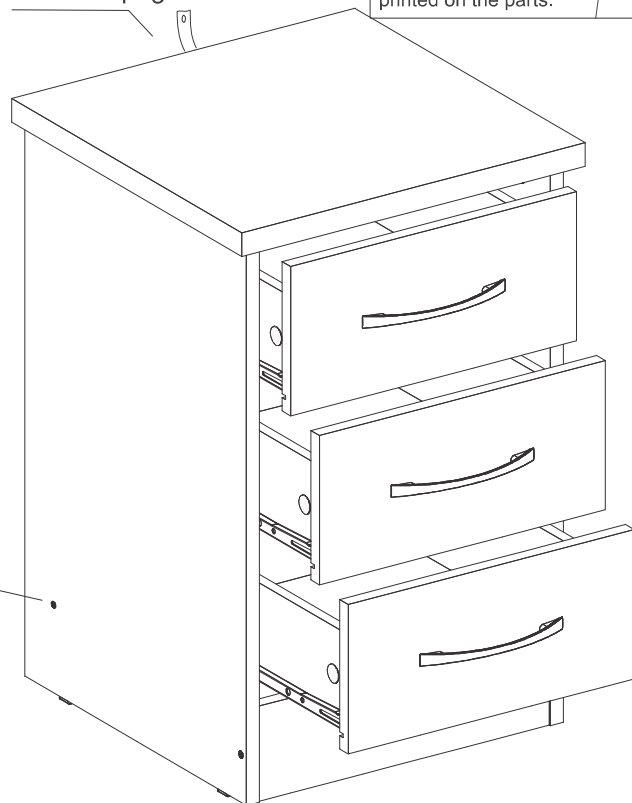
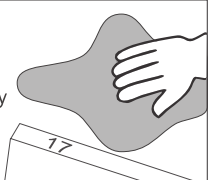

Detail 12

WARNING

Serious or fatal injuries can occur from furniture tipping over. To prevent the furniture from tipping over we recommend that it is permanently fixed to the wall.

Wall fixings are not supplied with this product as different wall materials require different types of fixing devices.

Please make sure you use fixings suitable for the walls in your home.

