

RIO 3' BED ASSEMBLY INSTRUCTIONS

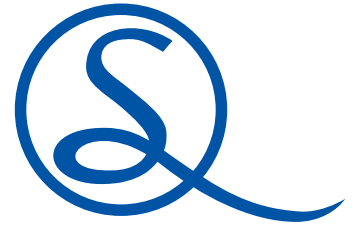
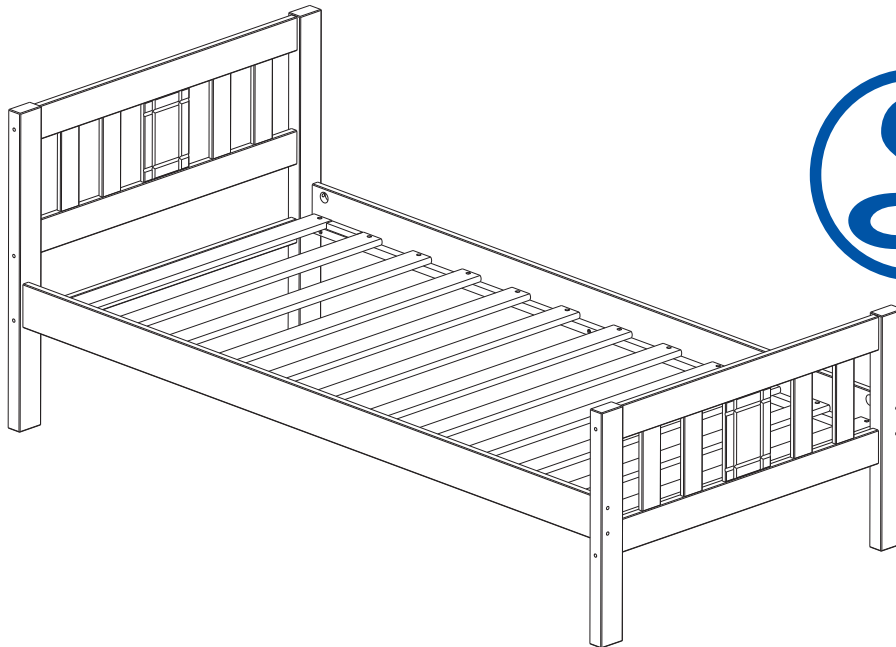

FOR DOMESTIC USE ONLY

IMPORTANT

PLEASE READ BEFORE YOU CONTINUE FURTHER

CARE AND MAINTENANCE

After unpacking this product please keep the original packaging in case it needs to be returned for any reason.

- Please ensure all fittings and parts are present before commencing with assembly.
- We recommend that you lay a blanket or sheet on the floor to avoid damage to both your floor and the product.
- We strongly recommend that you keep children away from your work area.
- Assemble this product as close to its final position as possible.
- Never drag or push products as this could cause damage to the joints making it inferior.
- Do not place this product next to a radiator or in direct sunlight.
- Wood is a natural product and may expand if subjected to damp and may shrink or crack if subjected to heat. Therefore it is recommended that room temperature is maintained, with no sudden temperature fluctuations.
- Make sure any spillage is wiped off immediately.
- Do not place hot or chilled items directly on to the surface, use a place mat or marking will occur.
- For general cleaning use a duster, and do not use detergents of any kind. However, the surface will need to be retreated from time to time. This can be done by using block wax (unperfumed) and rubbing it over the whole item.
- From time to time it may be necessary to tighten fittings, regular inspections should be carried out.

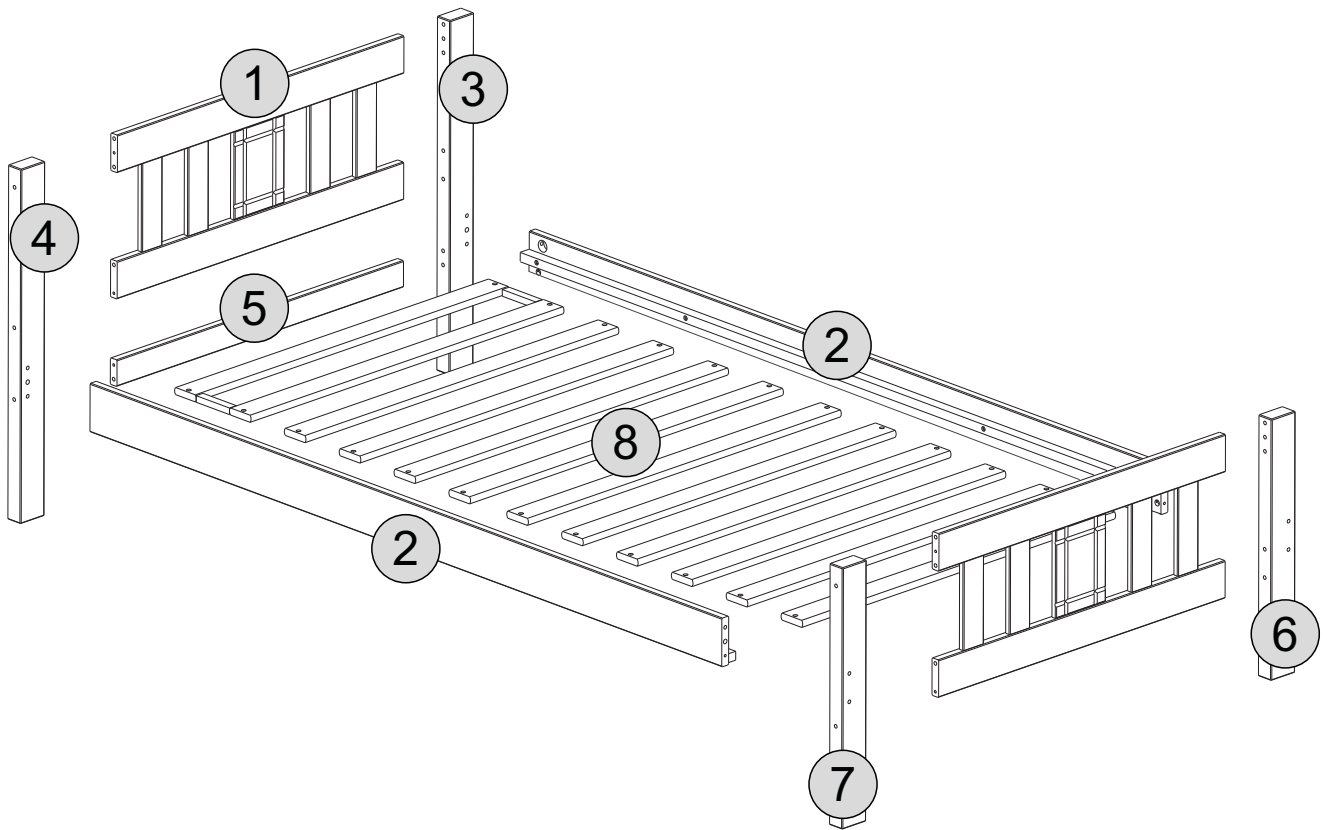







* Use of power tools to assemble this product will invalidate any claim and damage this product making it unsafe !!!
 * Please assemble on a clean soft surface to avoid damage.

* Please check contents and read the instructions before commencing assembly.
 * Assemble this product following the enclosed instructions carefully.
 * Please take care to avoid damaging panels during assembly.

PARTS LIST

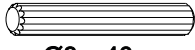
Part Number	Part Code	Part Description	Quantity	Carton
1	S200-201-034-LT1-01	Head/Footboard Panel	2	1/2
2	S200-201-034-LT1-02	Siderail	2	2/2
3	S200-201-034-LT1-03	Headboard Right Post	1	1/2
4	S200-201-034-LT1-04	Headboard Left Post	1	1/2
5	S200-201-034-LT1-05	Headboard Crossbeam	1	1/2
6	S200-201-034-LT1-06	Footboard Right Post	1	1/2
7	S200-201-034-LT1-07	Footboard Left Post	1	1/2
8	S200-201-034-LT1-08	Slats (2 Holes)	12	2/2

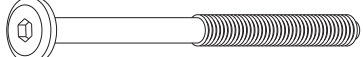
FITTINGS

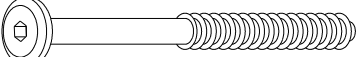
A 1/+	 Ø12 x 40mm	04	G 2/+	 Ø3,5 x 30mm	24
B 2/+	 Ø8 x 40mm	14	H		01
C	 17mm Ø1/4 x 90mm	08	I	 SPACER	02
D 1/+	 1/4	08			
E	 17mm Ø7 x 100mm	10			

TOOLS REQUIRED

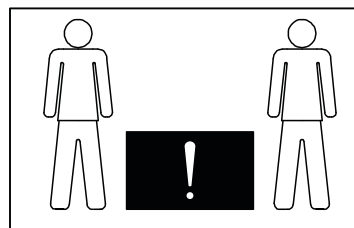
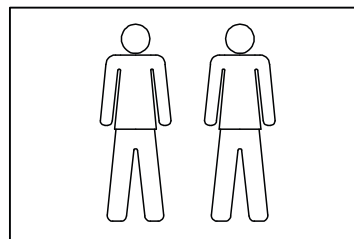
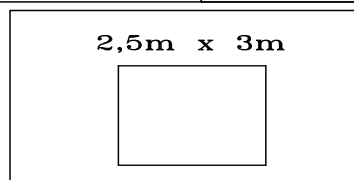
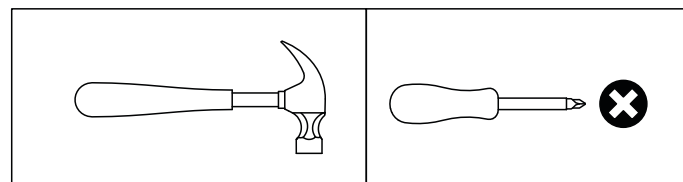

STEP 1

PARTS REQUIRED

2 - SIDERAIL x2

5 - HEADBOARD CROSSBEAM x1

HARDWARE REQUIRED

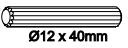
A  04

B  02

TOOLS REQUIRED

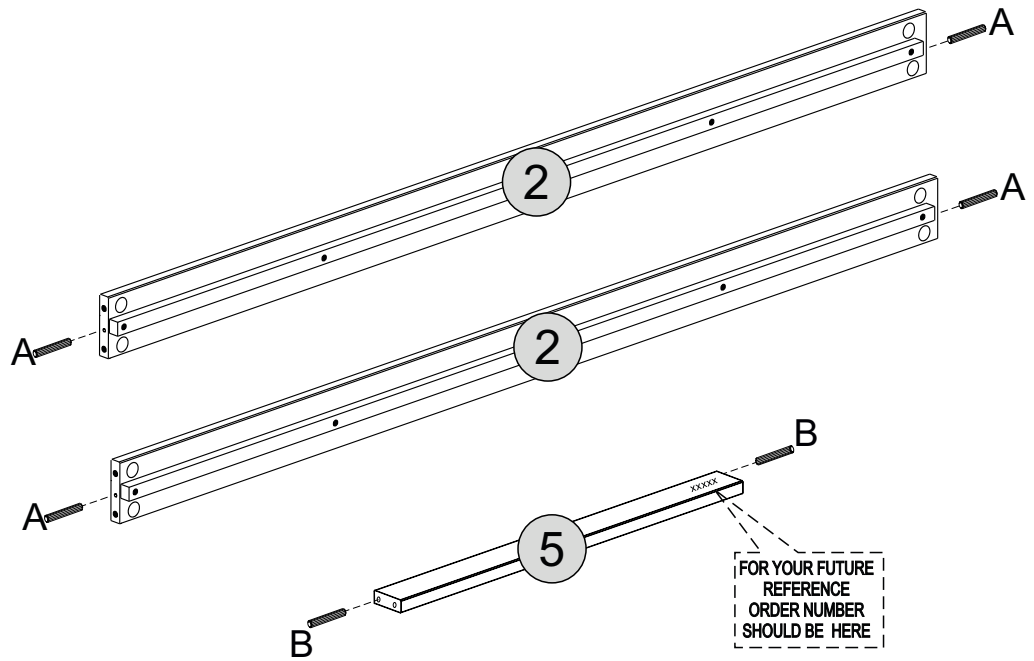

Please assemble on a clean soft surface to avoid damage.

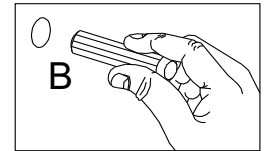
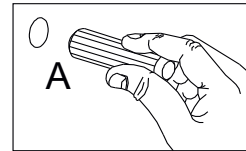

STEP 2

PARTS REQUIRED

1 - HEAD/FOOTBOARD PANEL x2

HARDWARE REQUIRED

B  12

TOOLS REQUIRED

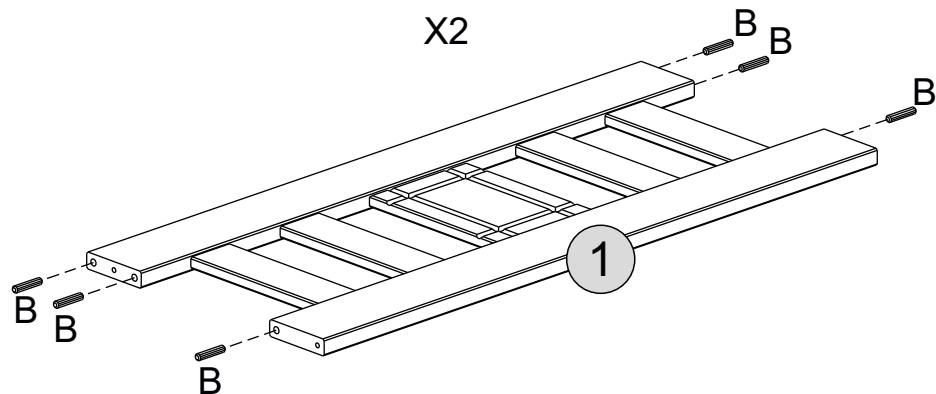

Please assemble on a clean soft surface to avoid damage.

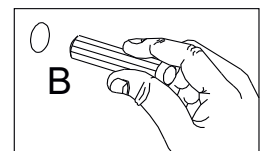

STEP 3

PARTS REQUIRED

1 - HEAD/FOOTBOARD PANEL x1

3 - HEADBOARD RIGHT POST x1

4 - HEADBOARD LEFT POST x1

5 - HEADBOARD CROSSBEAM x1

HARDWARE REQUIRED

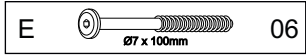

TOOLS REQUIRED

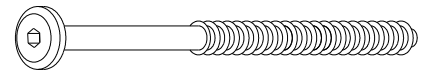
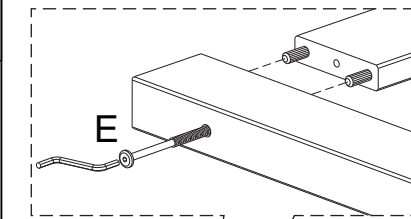
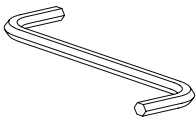

Ø7 x 100mm



Ø1/4 x 90mm

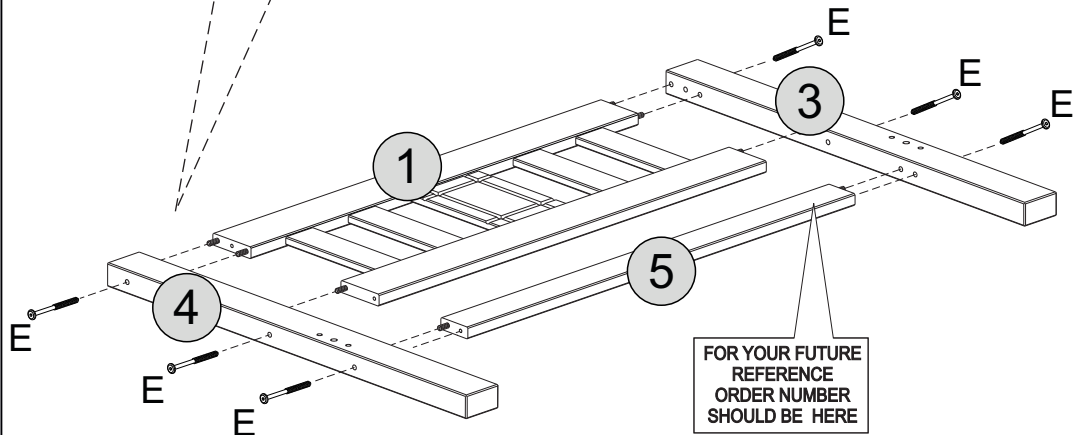

Please assemble on a clean soft surface to avoid damage.

STEP 4

PARTS REQUIRED

1 - HEAD/FOOTBOARD PANEL x1

6 - FOOTBOARD RIGHT POST x1

7 - FOOTBOARD LEFT POST x1

HARDWARE REQUIRED

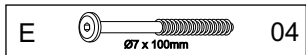

TOOLS REQUIRED

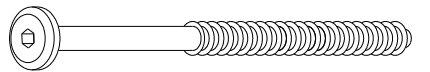
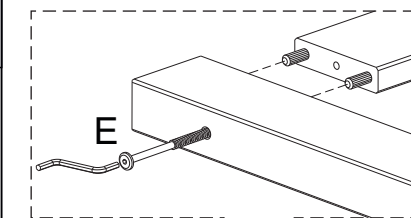
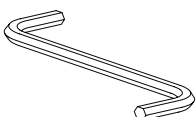

Ø7 x 100mm



Ø1/4 x 90mm

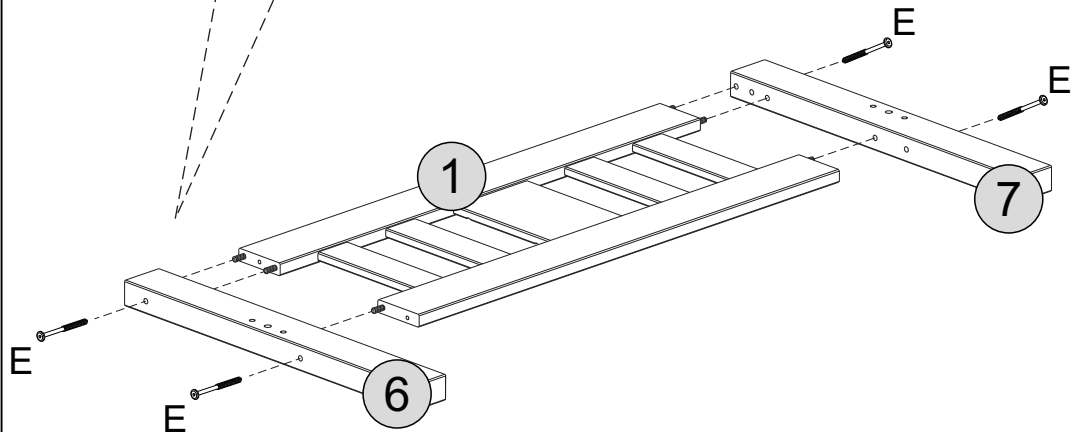

Please assemble on a clean soft surface to avoid damage.

STEP 5

PARTS REQUIRED

2 - SIDERAIL x2

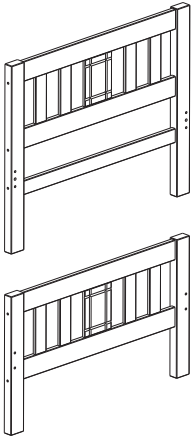

HARDWARE REQUIRED

C  Ø1/4 x 90mm 08

D  1/4 08

TOOLS REQUIRED

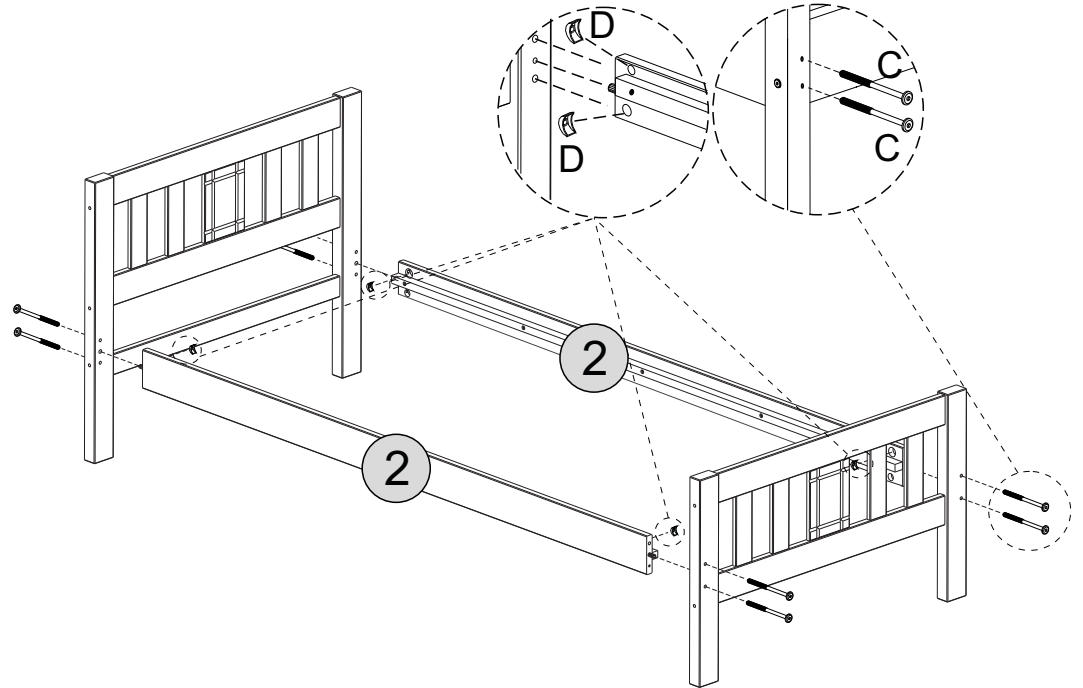
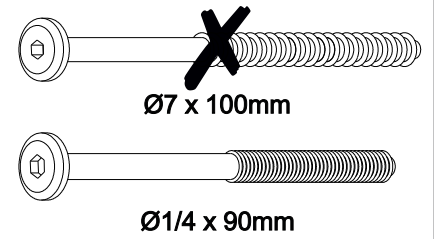
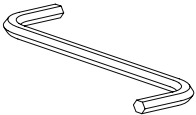

STEP 6

PARTS REQUIRED

8 - SLATS (2 HOLES) x2

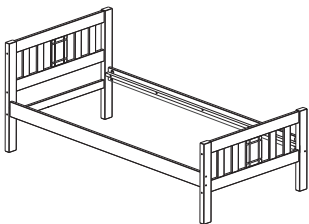

HARDWARE REQUIRED

G  Ø3,5 x 30mm 24

I  SPACER 87mm 02

TOOLS REQUIRED

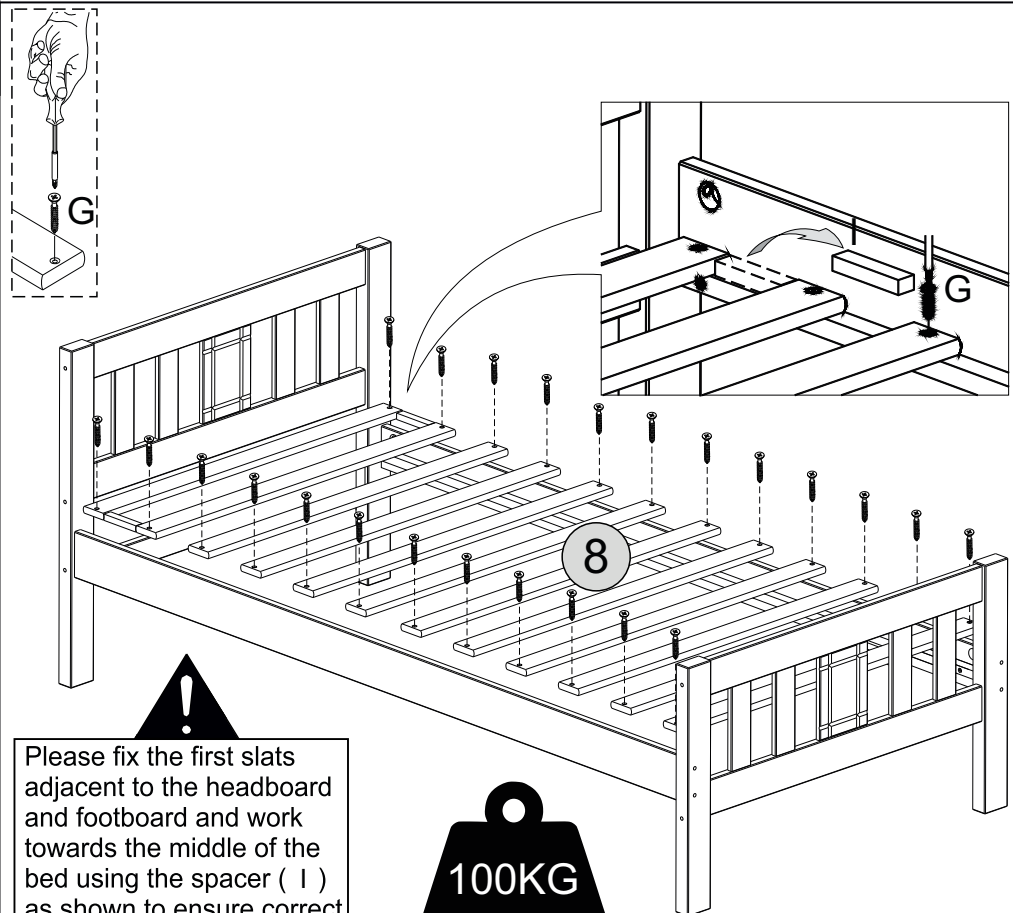
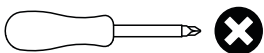

!
Please fix the first slats adjacent to the headboard and footboard and work towards the middle of the bed using the spacer (I) as shown to ensure correct spacing. Fix all the slats to one siderail first then push the second siderail tight against the slats and fix.

100KG
MAX BED WEIGHT