

56360

# RONAN 3' BED WAXED PINE ASSEMBLY INSTRUCTIONS

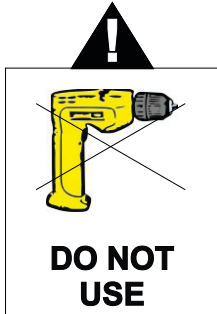

**MAX BED  
WEIGHT**

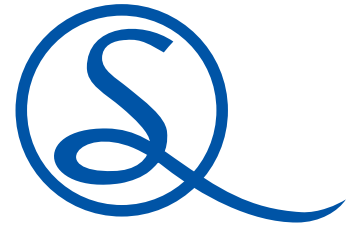

**FOR DOMESTIC USE ONLY**

**IMPORTANT**

**PLEASE READ BEFORE YOU CONTINUE FURTHER**

## **CARE AND MAINTENANCE**

After unpacking this product please keep the original packaging in case it needs to be returned for any reason.

- Please ensure all fittings and parts are present before commencing with assembly.
- We recommend that you lay a blanket or sheet on the floor to avoid damage to both your floor and the product.
- We strongly recommend that you keep children away from your work area.
- Assemble this product as close to its final position as possible.
- Never drag or push products as this could cause damage to the joints making it inferior.
- Do not place this product next to a radiator or in direct sunlight.
- Wood is a natural product and may expand if subjected to damp and may shrink or crack if subjected to heat. Therefore it is recommended that room temperature is maintained, with no sudden temperature fluctuations.
- Make sure any spillage is wiped off immediately.
- Do not place hot or chilled items directly on to the surface, use a place mat or marking will occur.
- For general cleaning use a duster, and do not use detergents of any kind. However, the surface will need to be retreated from time to time. This can be done by using block wax (unperfumed) and rubbing it over the whole item.
- From time to time it may be necessary to tighten fittings, regular inspections should be carried out.

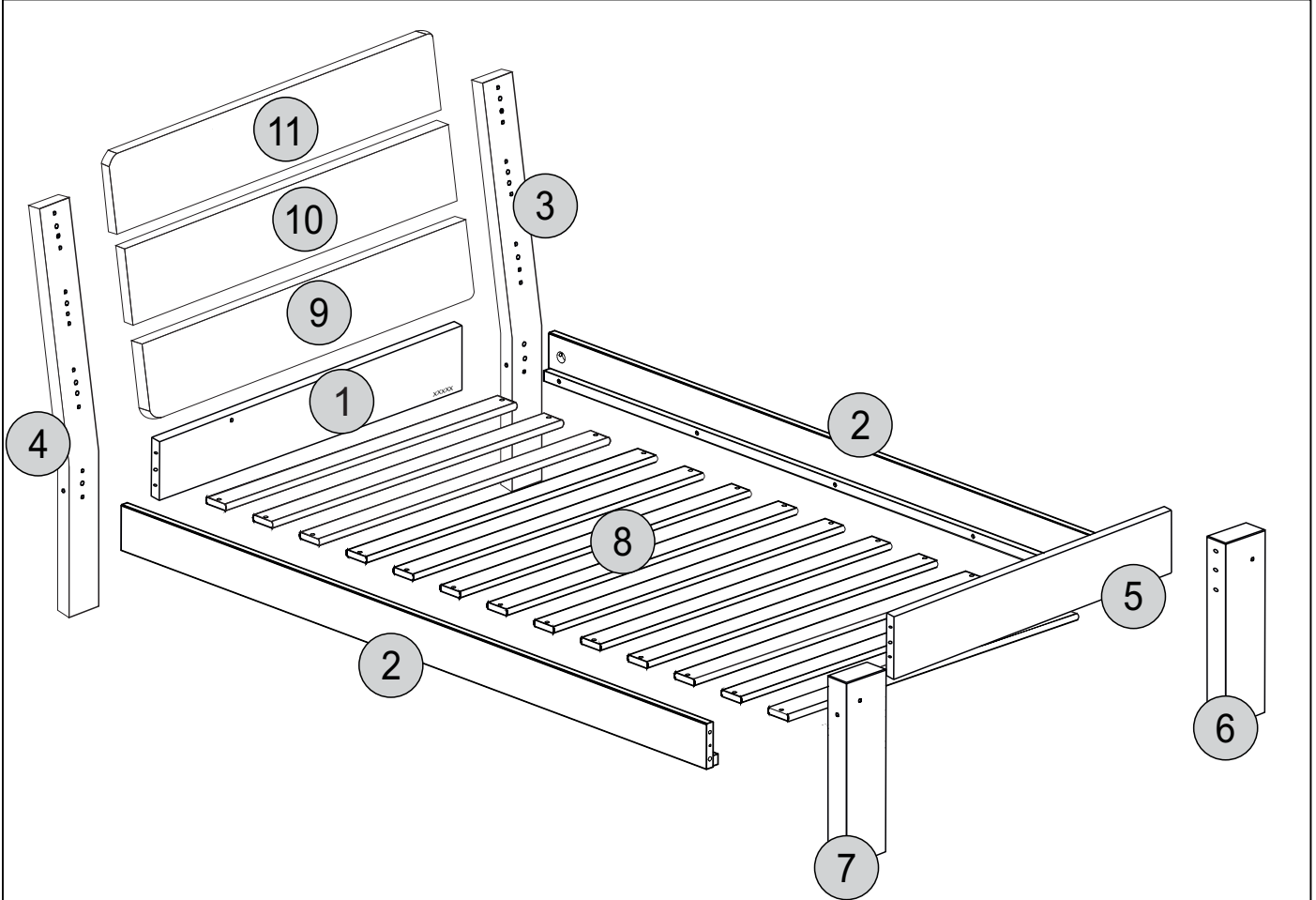

!   
 \* Use of power tools to assemble this product will invalidate any claim and damage this product making it unsafe !!!   
 \* Please assemble on a clean soft surface to avoid damage.

!   
 \* Please check contents and read the instructions before commencing assembly.   
 \* Assemble this product following the enclosed instructions carefully.   
 \* Please take care to avoid damaging panels during assembly.









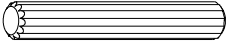

## PARTS LIST

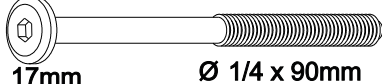
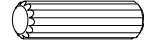
### *Please Note:*

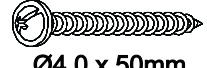
The below parts have all been stamped with the part number to help identify them during assembly.

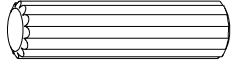
| Part Number | Part Code           | Part Description           | Quantity | Carton |
|-------------|---------------------|----------------------------|----------|--------|
| 1           | S200-201-074-PJ1-01 | Headboard Crossbeam        | 1        | 1/2    |
| 2           | S200-201-074-PJ1-02 | Siderail                   | 2        | 2/2    |
| 3           | S200-201-074-PJ1-03 | Headboard Right Post       | 1        | 1/2    |
| 4           | S200-201-074-PJ1-04 | Headboard Left Post (Blue) | 1        | 1/2    |
| 5           | S200-201-074-PJ1-05 | Footboard Panel            | 1        | 1/2    |
| 6           | S200-201-074-PJ1-06 | Footboard Right Post       | 1        | 1/2    |
| 7           | S200-201-074-PJ1-07 | Footboard Left Post (Blue) | 1        | 1/2    |
| 8           | S200-201-074-PJ1-08 | Slats                      | 13       | 1/2    |
| 9           | S200-201-074-PJ1-09 | Lower Headboard Panel      | 1        | 1/2    |
| 10          | S200-201-074-PJ1-10 | Centre Headboard Panel     | 1        | 1/2    |
| 11          | S200-201-074-PJ1-11 | Top Headboard Panel        | 1        | 1/2    |

### FITTINGS

|   |   |    |   |   |    |
|---|---|----|---|---|----|
| A | <br>Ø8 x 50mm<br>+/1       | 08 | G | <br>SPACER             | 02 |
| B | <br>17mm      Ø 1/4 x 90mm | 04 | H | <br>Ø8 x 30mm<br>+/2   | 12 |
| C | <br>1/4<br>+/1             | 04 | I | <br>Ø4,0 x 50mm<br>+/2 | 12 |
| D | <br>17mm      Ø7 x 100mm   | 04 | J | <br>Ø10 x 50mm<br>+/1  | 08 |
| E | <br>Ø4,0 x 30mm<br>+/2     | 26 | K | <br>GLUE               | 01 |
| F |                            | 01 |   |   |    |

### TOOLS REQUIRED

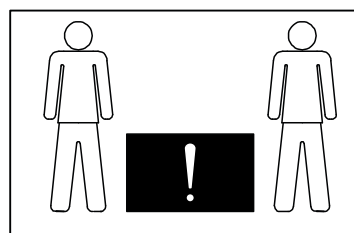
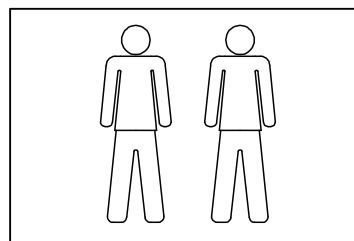
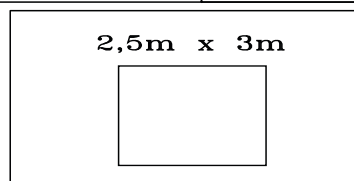
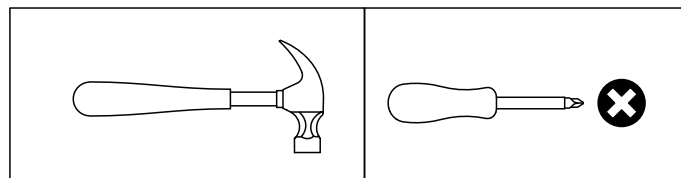

# STEP 1

## PARTS REQUIRED

1 - HEADBOARD CROSSBEAM x1

5 - FOOTBOARD PANEL x1

## HARDWARE REQUIRED

A  08  
Ø8 x 50mm

K  01  
GLUE

## TOOLS REQUIRED



Ø10 x 50mm



Ø8 x 50mm



Ø8 x 30mm

FOR YOUR FUTURE  
REFERENCE  
ORDER NUMBER  
SHOULD BE HERE

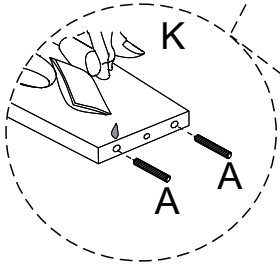
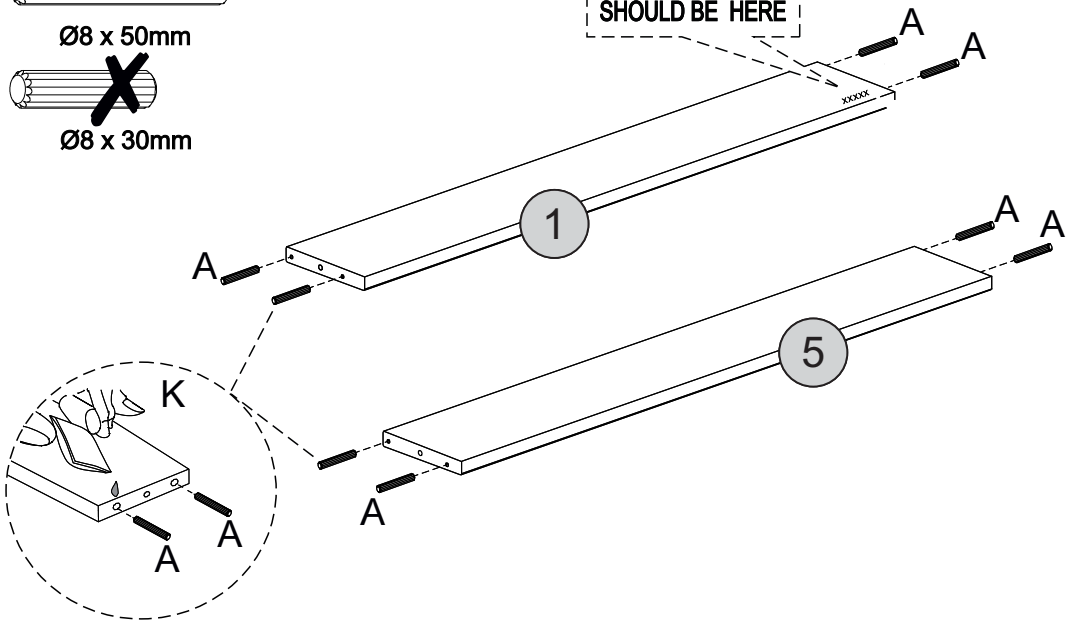

Please assemble on  
a clean soft surface  
to avoid damage.

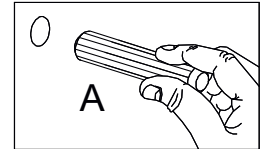

# STEP 2

## PARTS REQUIRED

2 - SIDERAIL x2

## HARDWARE REQUIRED

J  08  
Ø10x50mm

K  01  
GLUE

## TOOLS REQUIRED

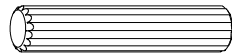

Ø10 x 50mm



Ø8 x 50mm



Ø8 x 30mm

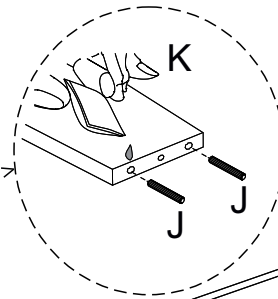
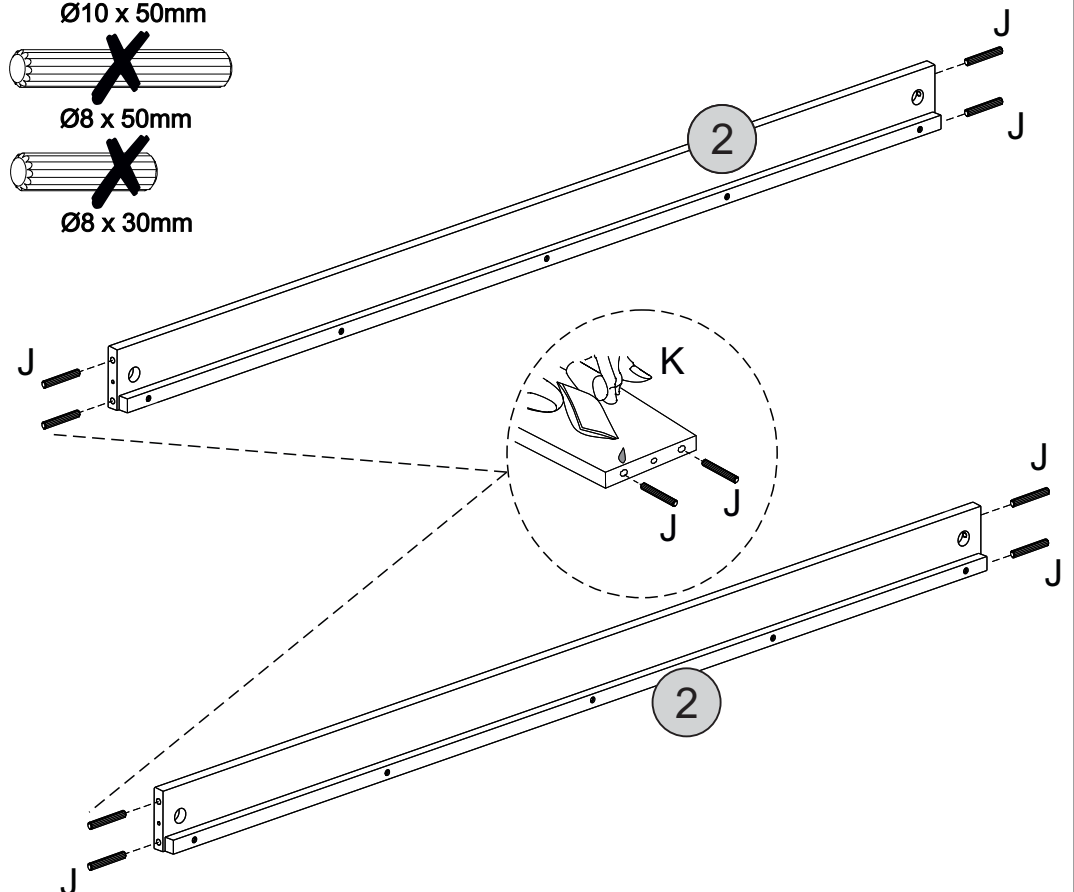

# STEP 3

## PARTS REQUIRED

3 - HEADBOARD RIGHT POST x1

4 - HEADBOARD LEFT POST(Blue)x1

## HARDWARE REQUIRED

H  12  
Ø8 x 30mm

K  01  
GLUE

## TOOLS REQUIRED

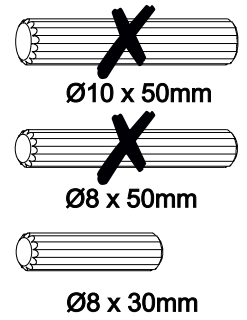
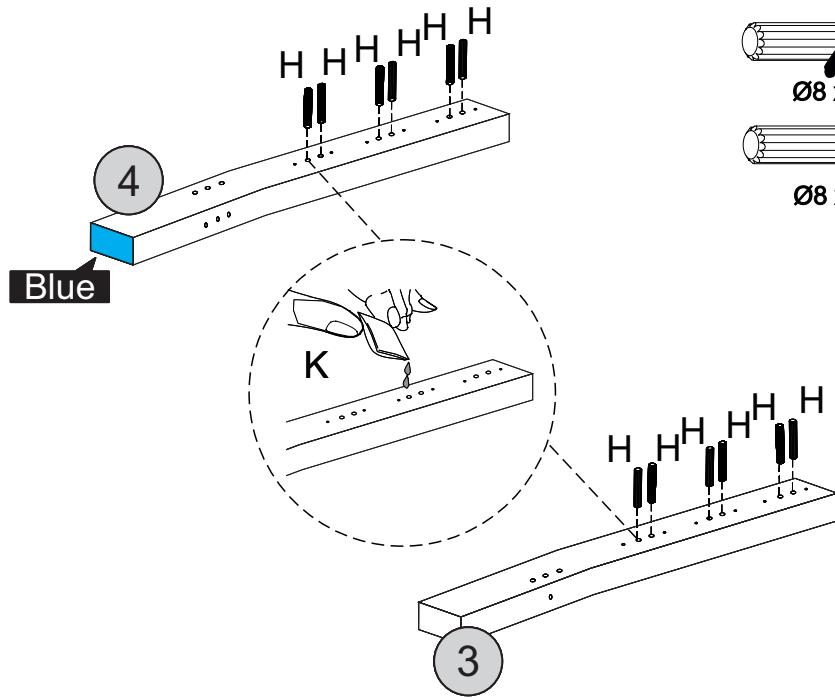

 Please assemble on a clean soft surface to avoid damage.

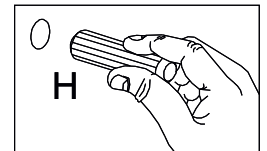

# STEP 4

## PARTS REQUIRED

1 - HEADBOARD CROSSBEAM x1

3 - HEADBOARD RIGHT POST x1

4 - HEADBOARD LEFT POST (Blue)x1

## HARDWARE REQUIRED

D  02  
Ø7 x 100mm

## TOOLS REQUIRED

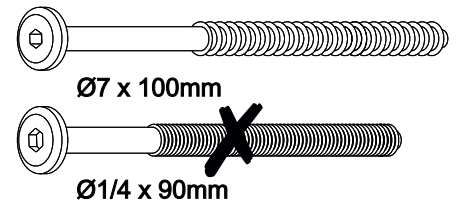
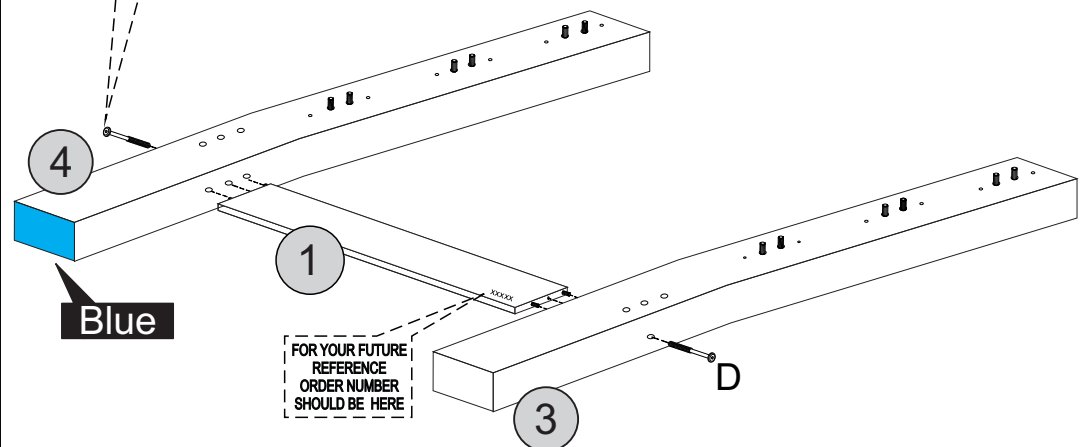
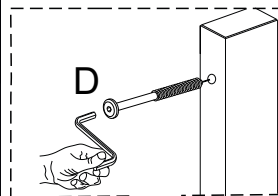
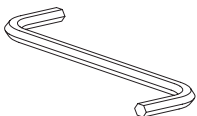

 Please assemble on a clean soft surface to avoid damage.

FOR YOUR FUTURE REFERENCE ORDER NUMBER SHOULD BE HERE

# STEP 5

## PARTS REQUIRED

9 - LOWER HEADBOARD PANEL x1

10 - CENTRE HEADBOARD PANEL x1

11 - TOP HEADBOARD PANEL x1

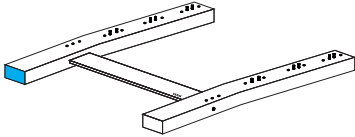

## HARDWARE REQUIRED

I  12  
Ø 4.0 x 50mm

K  01

## TOOLS REQUIRED

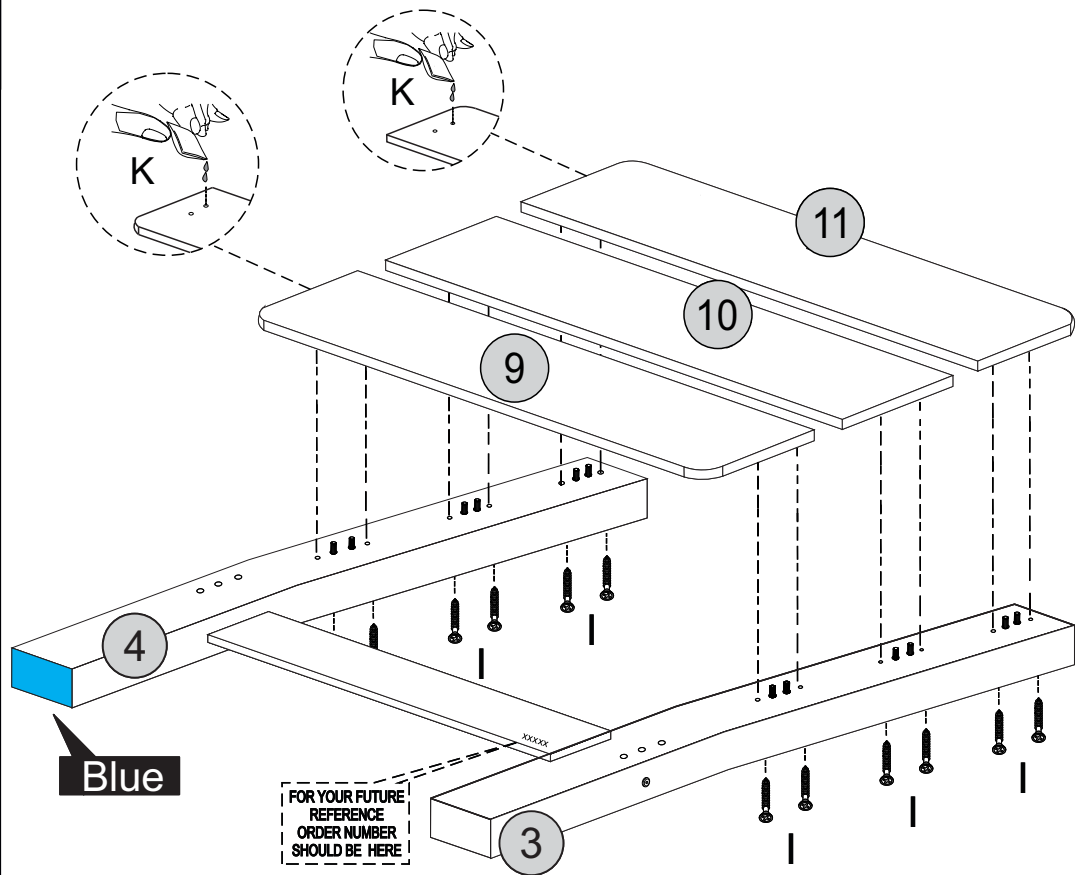
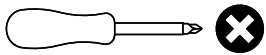

# STEP 6

## PARTS REQUIRED

5 - FOOTBOARD PANEL x1

6 - FOOTBOARD RIGHT POST x1

7 - FOOTBOARD LEFT POST (Blue) x1

## HARDWARE REQUIRED

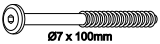
D  02  
Ø 7 x 100mm

## TOOLS REQUIRED

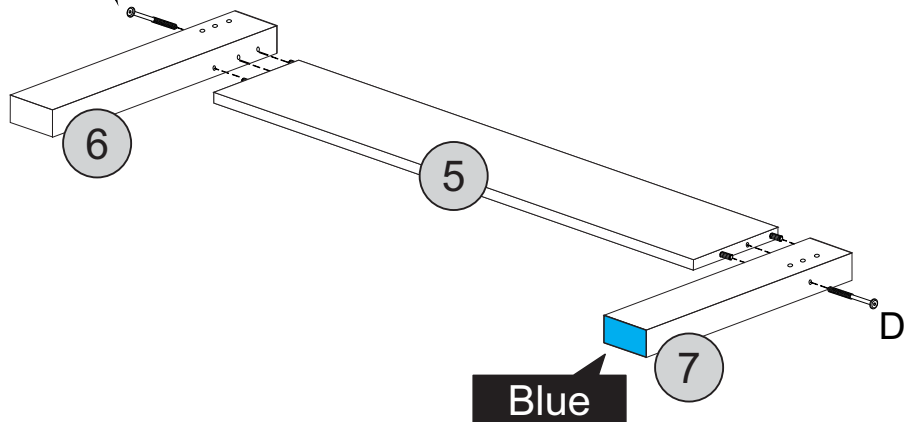
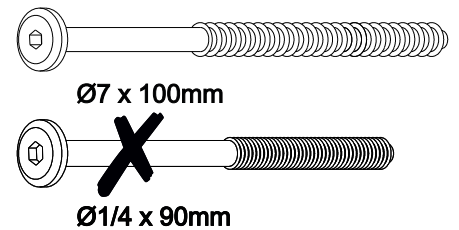
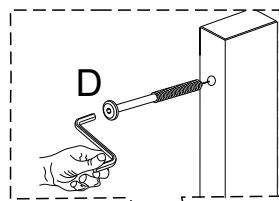
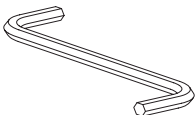

 Please assemble on a clean soft surface to avoid damage.

