

BLACK PU WAVERLEY 4' STORAGE BED ASSEMBLY INSTRUCTIONS

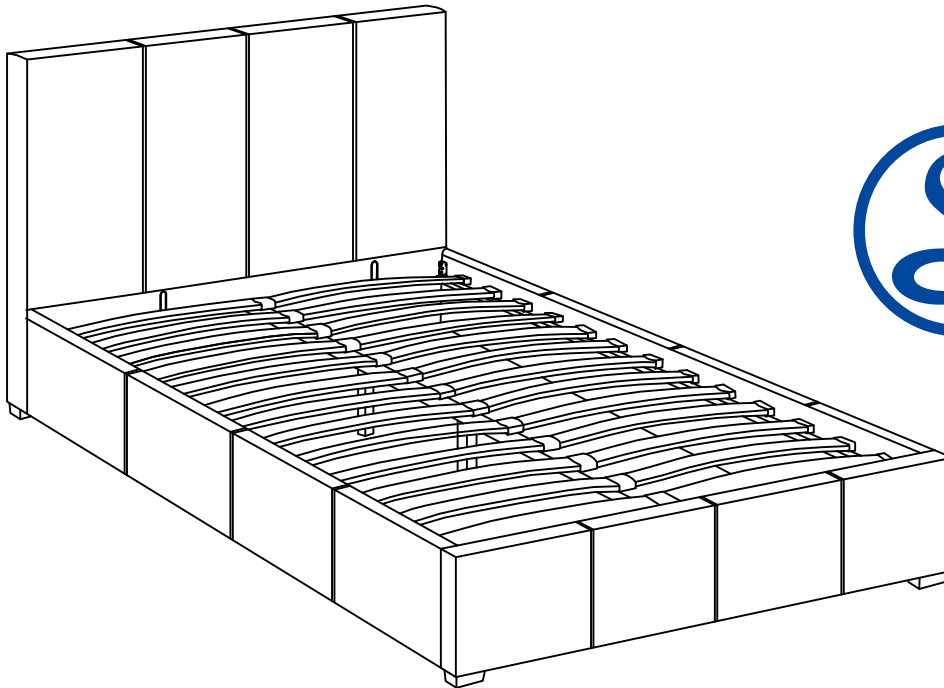

FOR DOMESTIC USE ONLY **IMPORTANT**

PLEASE READ BEFORE YOU CONTINUE FURTHER

THE PRODUCT YOU HAVE PURCHASED WILL GIVE YOU MANY YEARS OF SERVICE IF YOU FOLLOW THE GUIDELINES FOR ITS SAFE ASSEMBLY AND PERIODIC MAINTENANCE AND CLEANING.

ASSEMBLE ON A SOFT CLEAN SURFACE.

DO NOT USE ANY TOOLS OTHER THAN THOSE SHOWN.

ANY SPANNERS OR ALLEN KEYS REQUIRED ARE INCLUDED WITH THE FITTINGS KIT.

DO NOT FOR ANY REASON USE A POWER TOOL TO ASSEMBLE THIS PRODUCT. ITS USE WILL INVALIDATE ANY CLAIM YOU MAY HAVE AND COULD MAKE THIS PRODUCT UNSAFE.

DEPENDING ON THE AMOUNT OF USE THIS PRODUCT RECEIVES IT MAY BE NECESSARY TO TIGHTEN UP THE FIXINGS FROM TIME TO TIME. THIS IS COMPLETELY NORMAL FOR ANY FLAT PACK FURNITURE.
DO NOT OVERTIGHTEN FIXINGS.

FOR CLEANING, YOU MAY USE A DAMP CLOTH (NOT WET) DO NOT USE POLISH, DETERGENT OR CHEMICAL CLEANERS





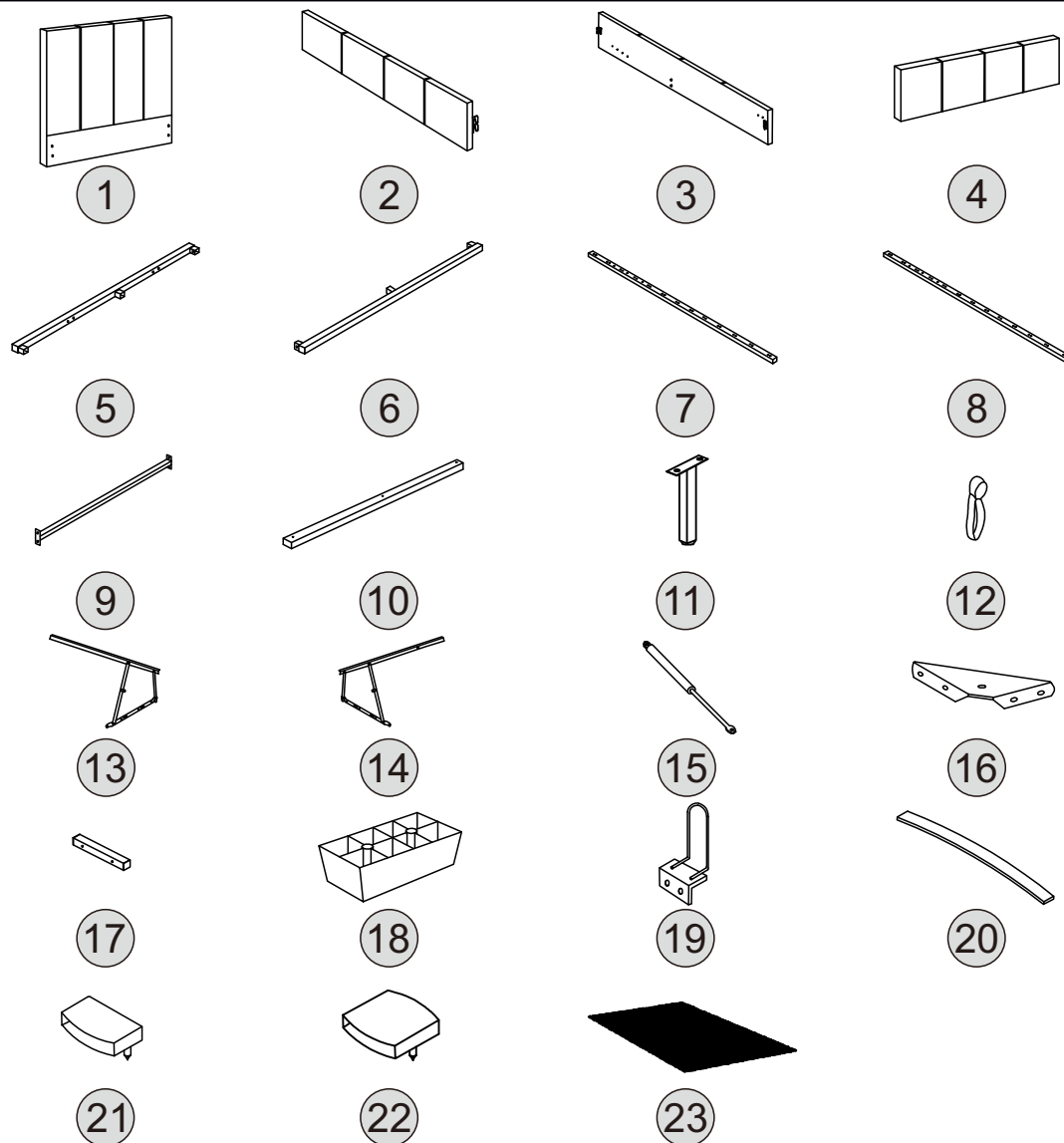





THIS PRODUCT MAY STAIN OR MARK IF ALLOWED TO COME INTO CONTACT WITH WET OR DAMP OBJECTS AS MATERIALS USED HAVE NOT BEEN SCOTCH GUARDED.

THE SURFACE OF THIS ITEM IS NOT HEAT RESISTANT. ALWAYS USE A PLACE MAT UNDER HOT OR COLD ITEMS TO PREVENT MARKING.

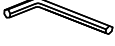
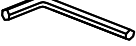

Part Number	Part Code	Part Description	Quantity	Carton
1	S200-202-006-HA1-01	Headboard	1	1/2
2	S200-202-006-HA1-02	Footboard	1	2/2
3	S200-202-006-HA1-03	Left Side Rail	1	2/2
4	S200-202-006-HA1-04	Right Side Rail	1	2/2
5	S200-202-006-HA1-05	Front Frame Rail	1	2/2
6	S200-202-006-HA1-06	Back Frame Rail	1	2/2
7	S200-202-006-HA1-07	Frame Centre Rail	1	2/2
8	S200-202-006-HA1-08	Front Side Rail	2	2/2
9	S200-202-006-HA1-09	Centre Frame Rail	1	2/2
10	S200-202-006-HA1-10	Cross Rail	1	2/2
11	S200-202-006-HA1-11	Support Leg	2	2/2
12	S200-202-006-HA1-12	Strap	1	2/2
13	S200-202-006-HA1-13	Left Lifting Arm	1	2/2
14	S200-202-006-HA1-14	Right Lifting Arm	1	2/2
15	S200-202-006-HA1-15	Gas Lift	2	2/2
16	S200-202-006-HA1-16	Corner Bracket	2	2/2
17	S200-202-006-HA1-17	Support Block	1	2/2
18	S200-202-006-HA1-18	Feet	4	2/2
19	S200-202-006-HA1-19	Mattress Support	2	2/2
20	S200-202-006-HA1-20	Sprung Slats	26	1/2
21	S200-202-006-HA1-21	Plastic Slit Caps	26	2/2
22	S200-202-006-HA1-22	Centre Slat Caps	13	2/2
23	S200-202-006-HA1-23	Woven fabric	1	1/2

HARDWARE LIST

REF		HARDWARE NAME	QTY
A		5/16x2" BOLT	5 PCS
B		5/16x1" BOLT	8 PCS
C		5/16x3/4" BOLT	6 PCS
D		1/4x3/4" BOLT	34 PCS
E		5/16"x19mm FLAT WASHER	53 PCS
F		5/16"x13mm SPRING WASHER	33 PCS
G		5/16"x12mm	7 PCS
H		#7*1-1/2 Screw	8 PCS
I		M4 ALLEN KEY	1 PC
J		M5 ALLEN KEY	1 PC
K		12mm SPANNER	1 PC

PLEASE CHECK THAT YOU HAVE ALL THE PARTS LISTED BEFORE YOU START ASSEMBLING. IF YOU DO FIND THAT SOMETHING IS MISSING. DO NOT CONTINUE ASSEMBLY. PLEASE CONTACT YOUR SUPPLIER IMMEDIATELY.

Important information!

The gas lifts used in the construction of this product are extremely strong and cannot be operated by hand when not fitted to the ottoman hinges. All gas lifts are tested in the factory for correct pressure and operation before use.

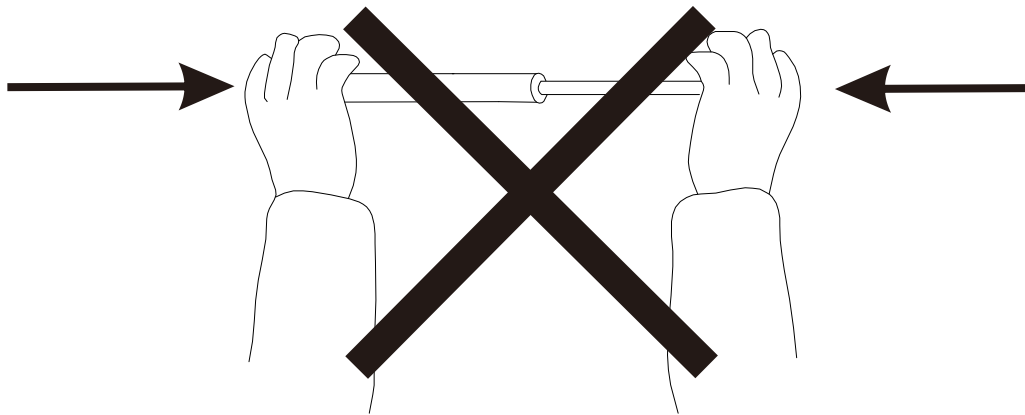

You must ensure the **MATTRESS** is on the bed frame before lifting the mechanism.
FAILURE TO DO SO MAY RESULT IN INJURY.

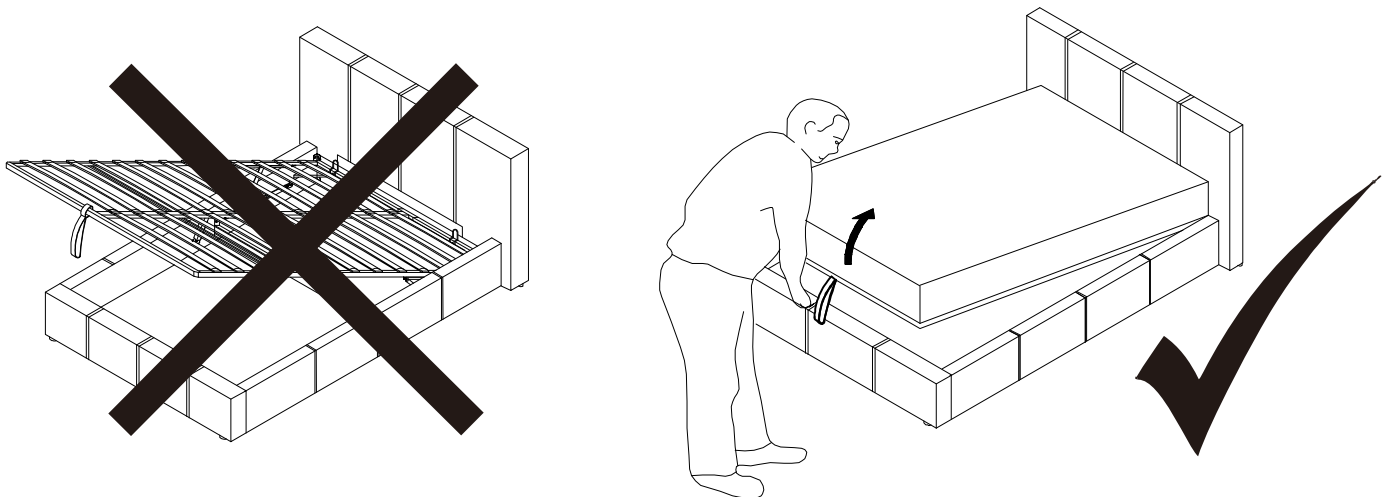

Initially it might appear that the gas lifts are very stiff when opening and closing the ottoman frame, **THIS IS NORMAL.**

After operating the ottoman a few times, the movement of the gas lifts and the opening and closing of the ottoman will become easier.

STEP 1

PARTS REQUIRED

1 - HEADBOARD	x1
18 - FEET	x2

HARDWARE REQUIRED

H		04
---	---	----

TOOLS REQUIRED

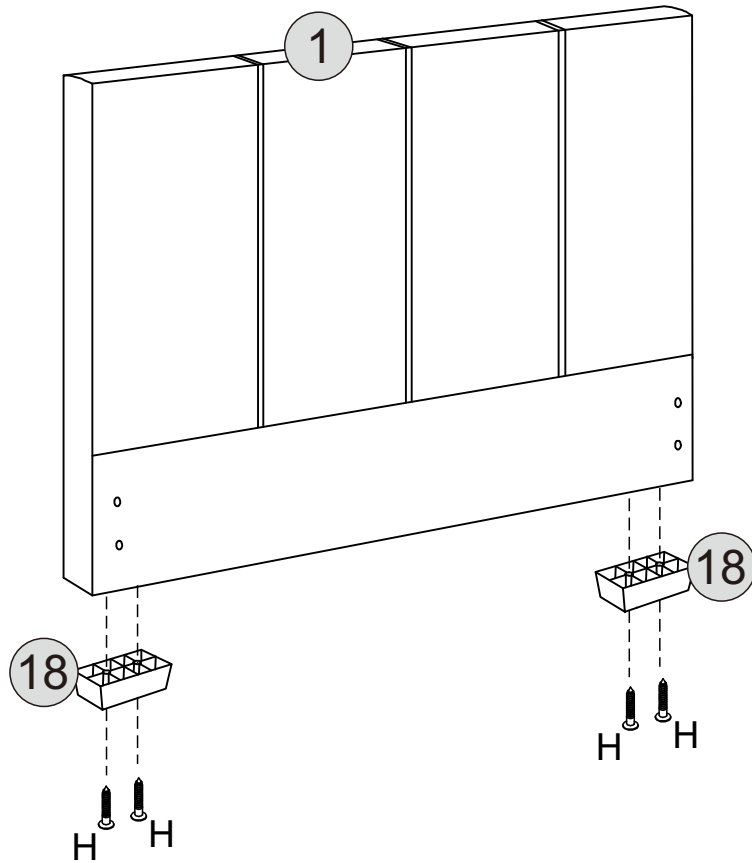
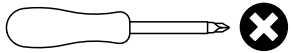

STEP 2

PARTS REQUIRED

2 - FOOTBOARD	x1
18 - FEET	x2

HARDWARE REQUIRED

H		04
---	---	----

TOOLS REQUIRED

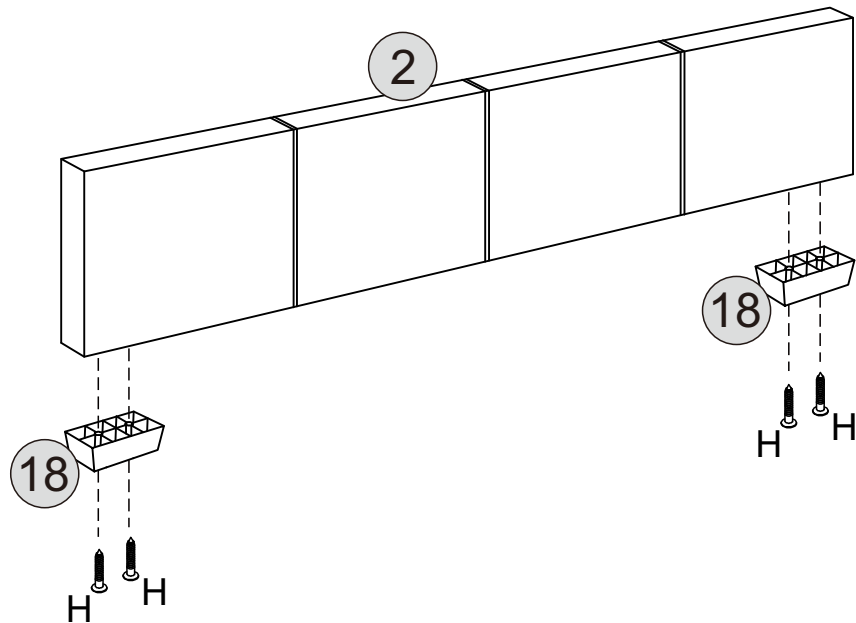
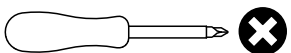



STEP 3

PARTS REQUIRED

2 - FOOTBOARD	x1
17 - SUPPORT BLOCK	x1

HARDWARE REQUIRED

A		02
E		02

TOOLS REQUIRED

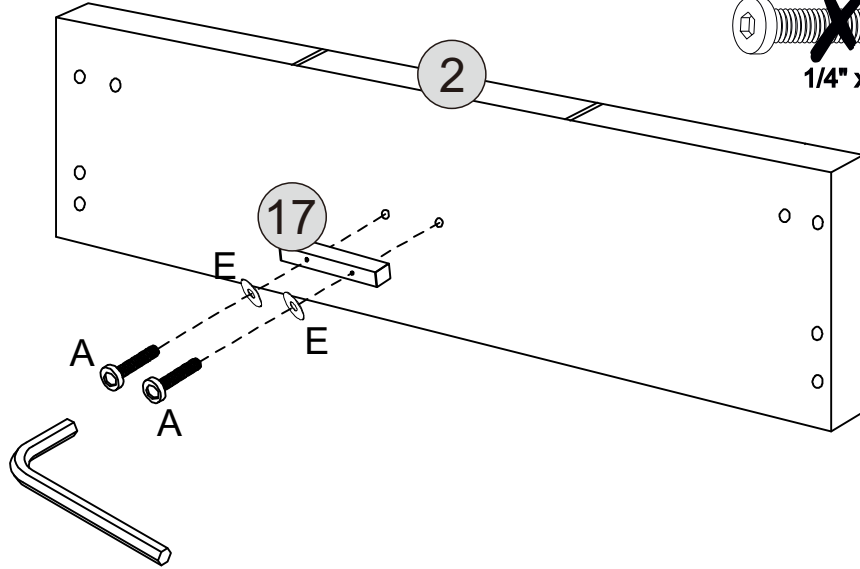
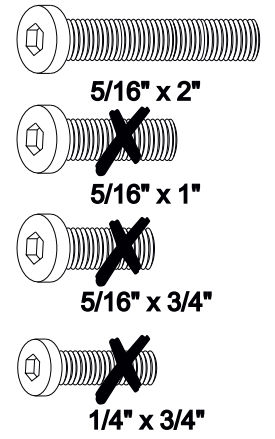
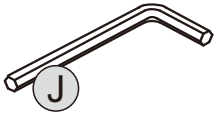



STEP 4

PARTS REQUIRED

1 - HEADBOARD	x1
2 - FOOTBOARD	x1
3 - LEFT SIDERAIL	x1
4 - RIGHT SIDERAIL	x1

HARDWARE REQUIRED

B		08
E		08
F		08

TOOLS REQUIRED

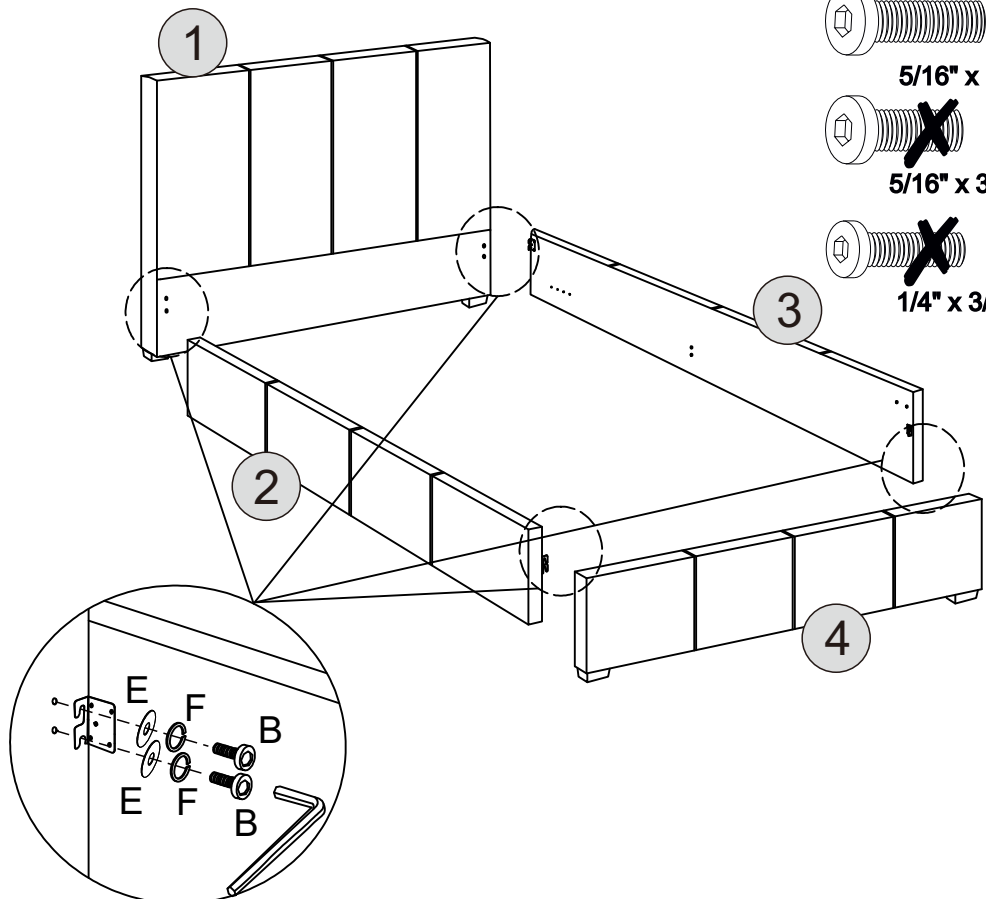
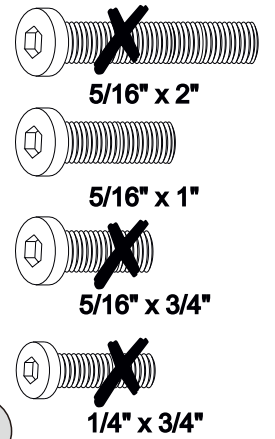

STEP 5

PARTS REQUIRED

16 - CORNER BRACKET x2

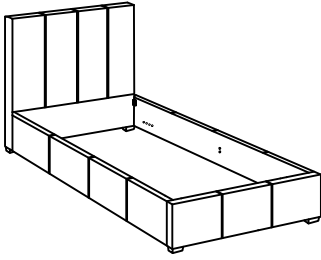

HARDWARE REQUIRED

D		08
E		08

TOOLS REQUIRED

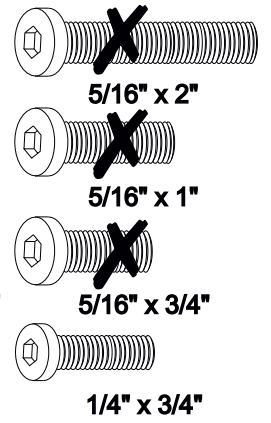
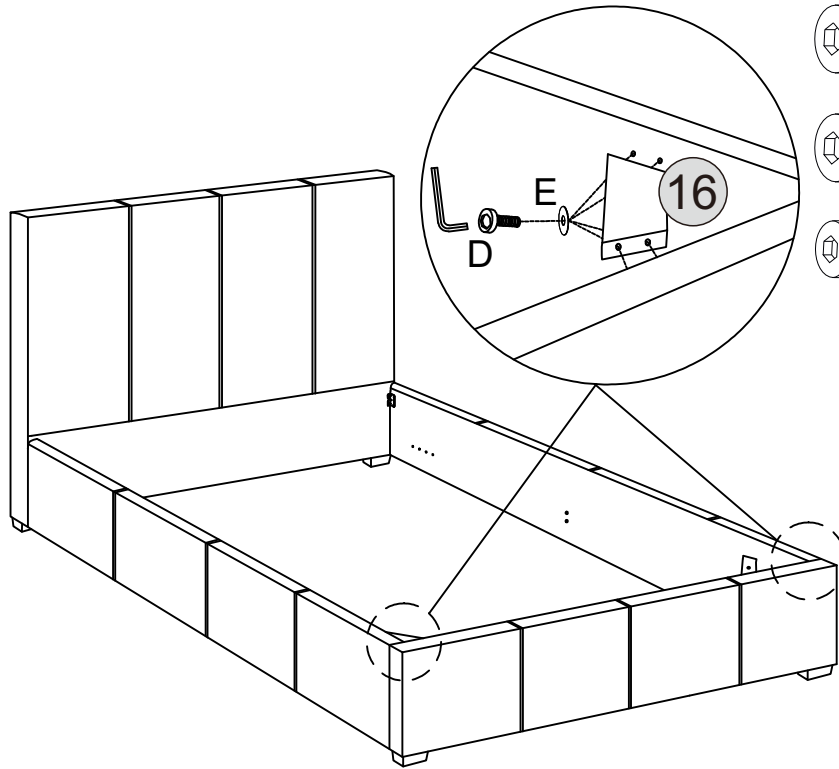
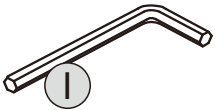

STEP 6

PARTS REQUIRED

5 - FRONT FRAME RAIL	x1
6 - BACK FRAME RAIL	x1
7 - FRAME CENTRE RAIL	x1
8 - FRONT SIDE RAIL	x2
12 - STRAP	x1

HARDWARE REQUIRED

C		06
E		06
F		06

TOOLS REQUIRED

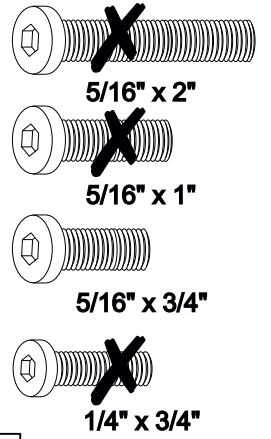
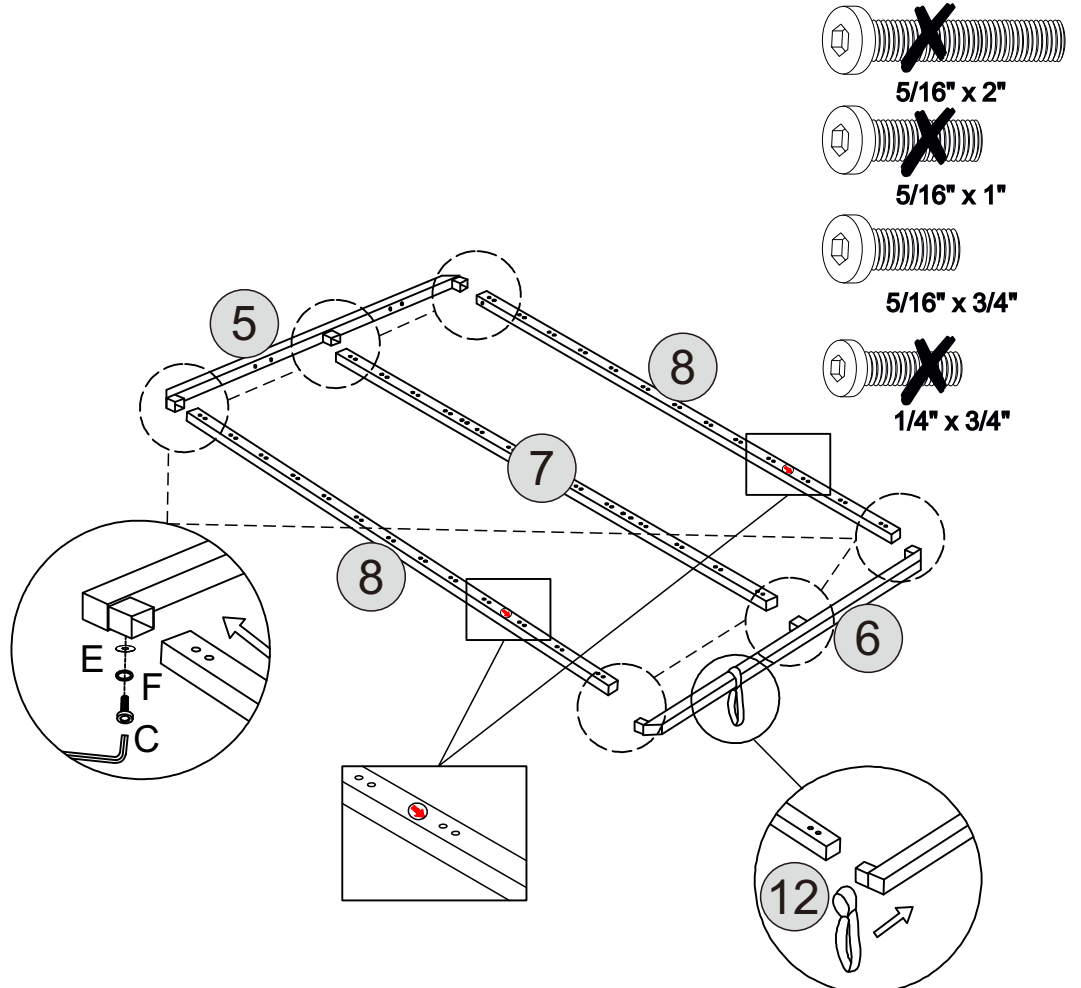
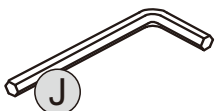

STEP 7

PARTS REQUIRED

10 - CROSSRAIL x1

19 - MATTRESS SUPPORT x2

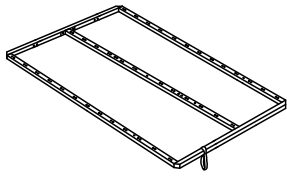

HARDWARE REQUIRED

A 03
5/16" x 2"

D 04
1/4" x 3/4"

E 07

F 07

G 03

TOOLS REQUIRED

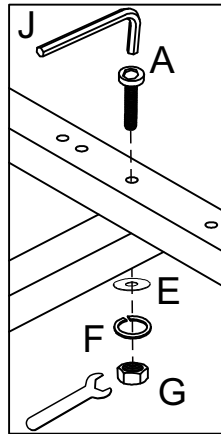
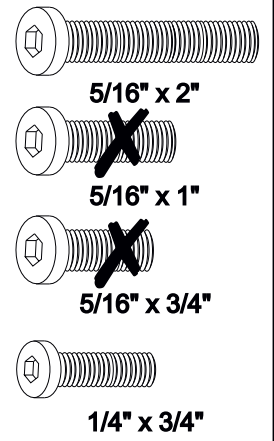
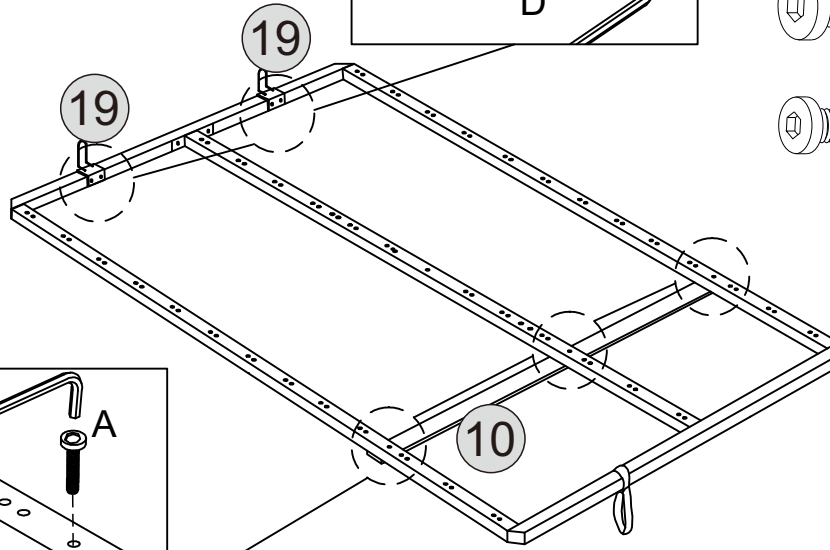
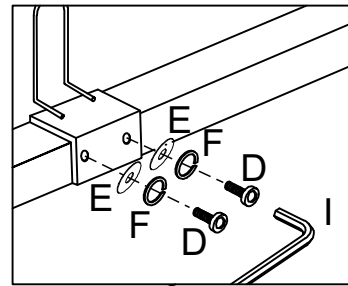
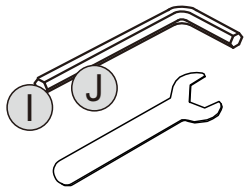

STEP 8

PARTS REQUIRED

11 - SUPPORT LEG x2

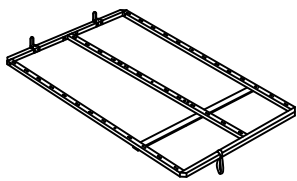

HARDWARE REQUIRED

D 04
1/4" x 3/4"

E 04

F 04

TOOLS REQUIRED

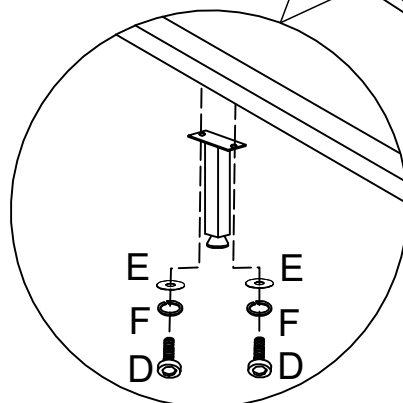
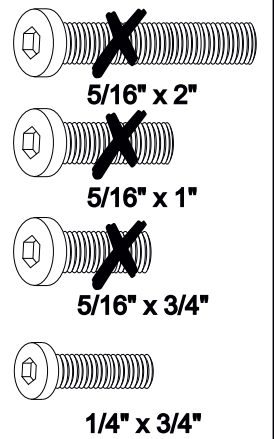
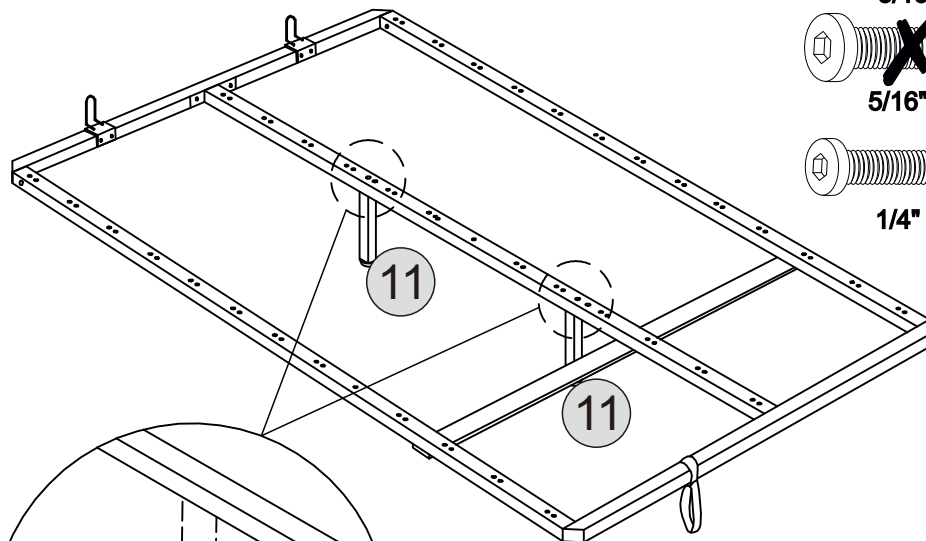
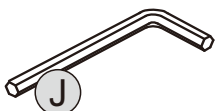

STEP 9

PARTS REQUIRED

13 - LEFT LIFTING ARM x1

14 - RIGHT LIFTING ARM x1

15 - GAS LIFT x2

HARDWARE REQUIRED

G  04

TOOLS REQUIRED

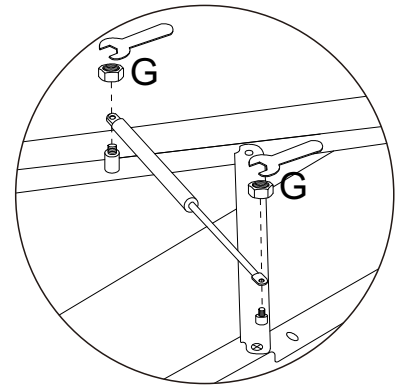
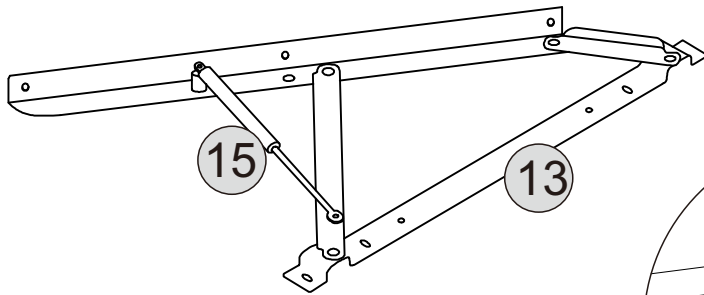
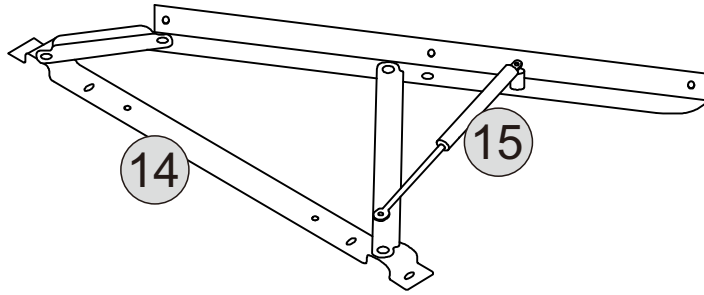
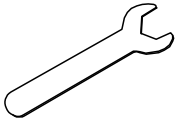

STEP 10

PARTS REQUIRED

9 - CENTRE FRAME RAIL x1

13 - LEFT LIFTING ARM x1

14 - RIGHT LIFTING ARM x1

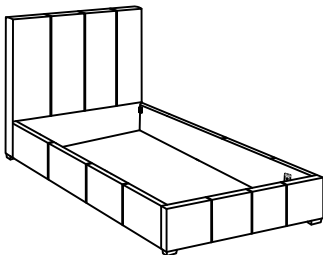

HARDWARE REQUIRED

D  12

E  12

F  08

TOOLS REQUIRED

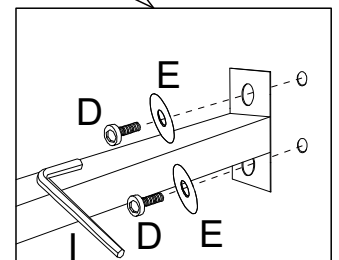
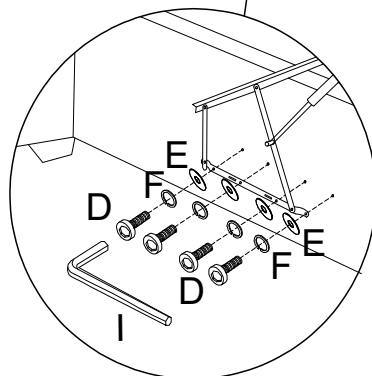
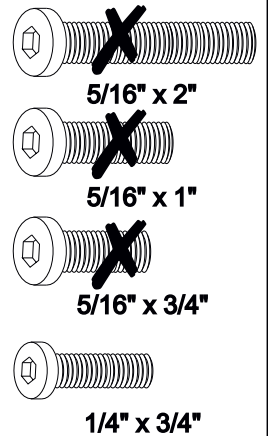
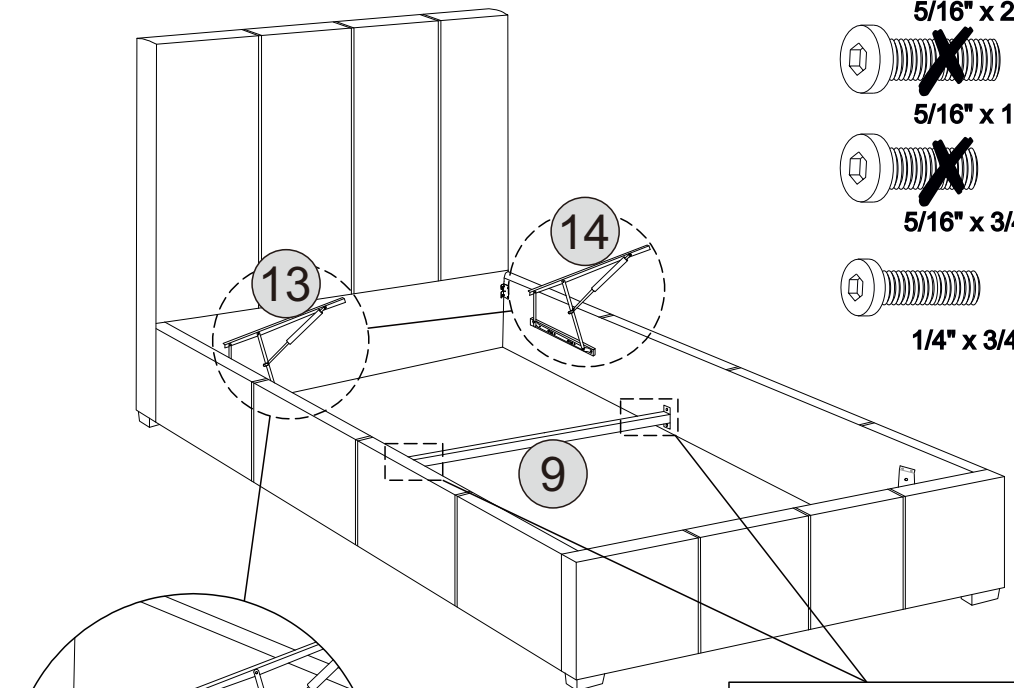
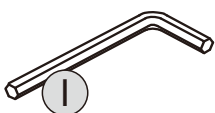

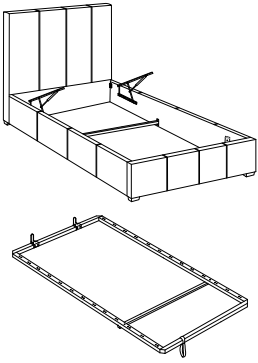

STEP 11

PARTS REQUIRED



HARDWARE REQUIRED

D	 1/4" x 3/4"	06
E		06

TOOLS REQUIRED

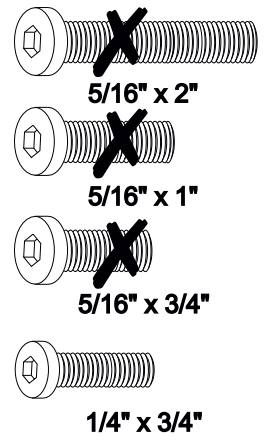
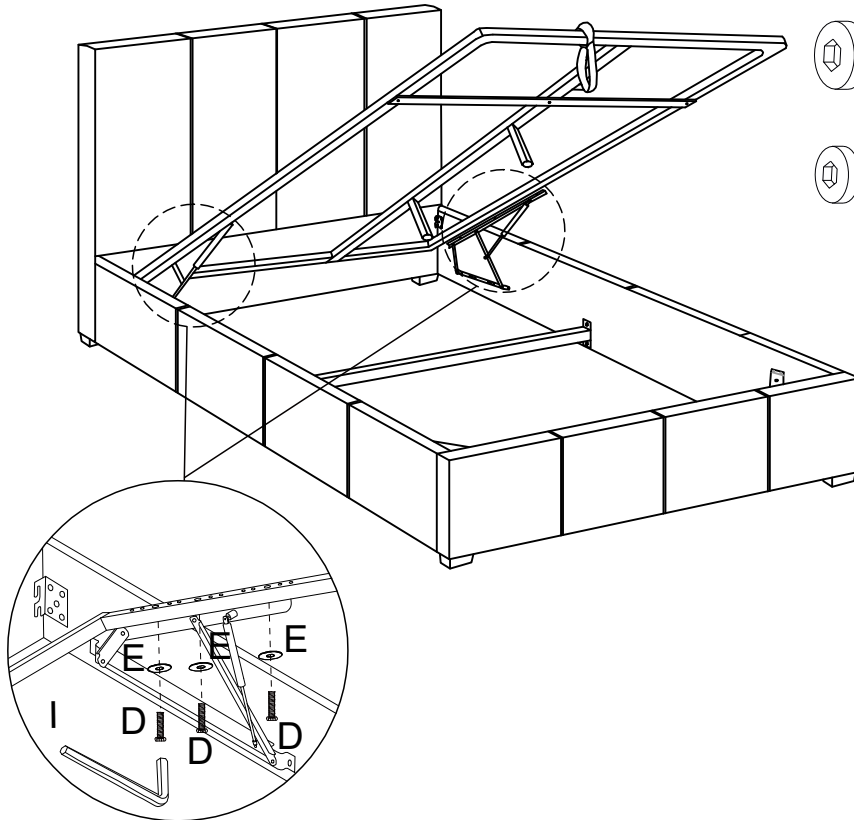
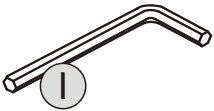

STEP 12

PARTS REQUIRED

23 - WOVEN FABRIC	x1
-------------------	----

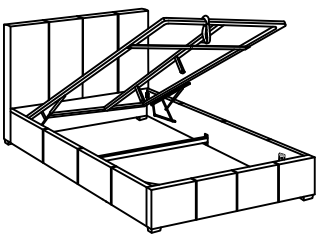

HARDWARE REQUIRED

TOOLS REQUIRED

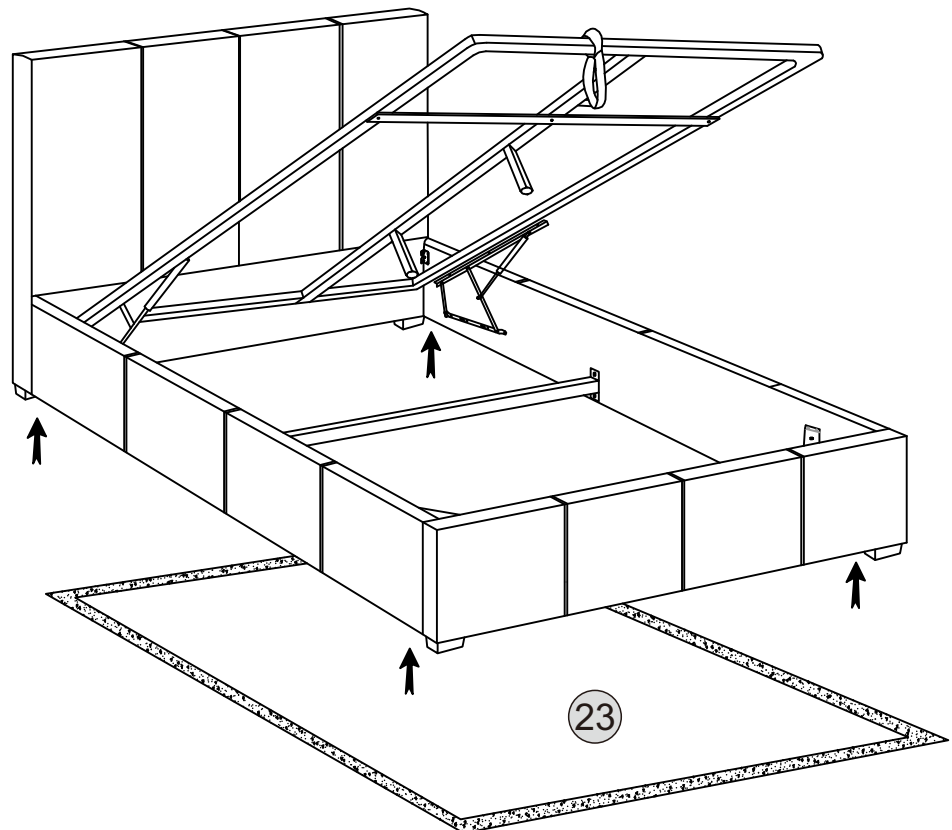

STEP 13

PARTS REQUIRED

20 - SPRUNG SLATS x26

21 - PLASTIC SLAT CAPS x26

22 - CENTRE SLAT CAPS x13

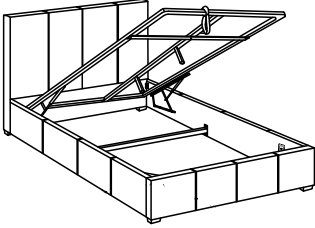

HARDWARE REQUIRED

TOOLS REQUIRED

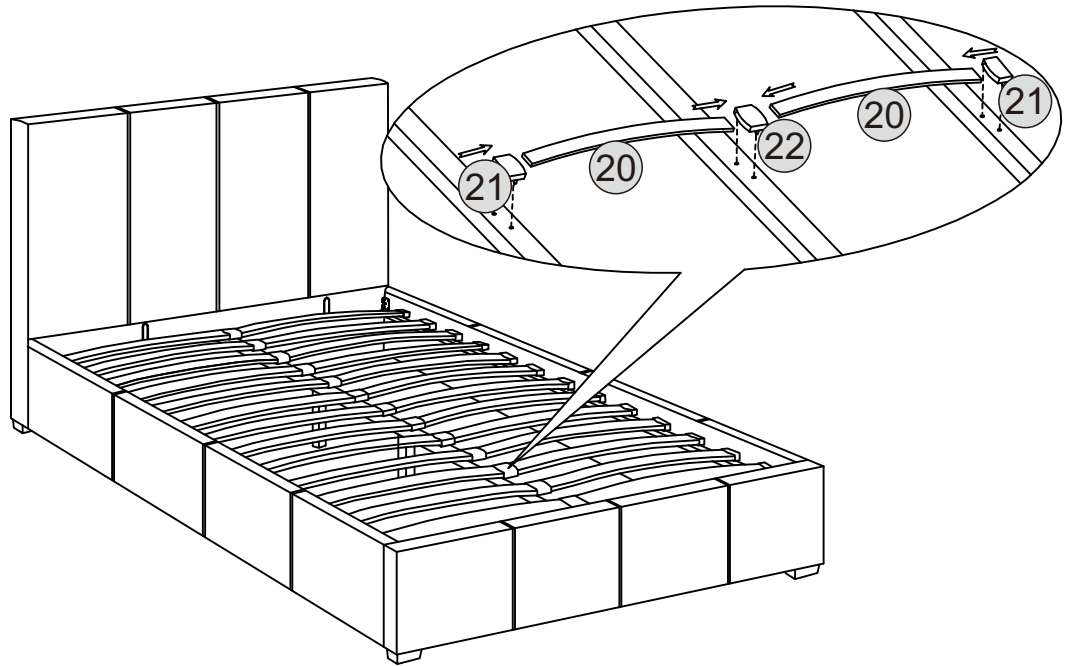

STEP 14

PARTS REQUIRED

HARDWARE REQUIRED

TOOLS REQUIRED

