

56878

ANTIQUE PINE AMBER 4'6" BED ASSEMBLY INSTRUCTIONS

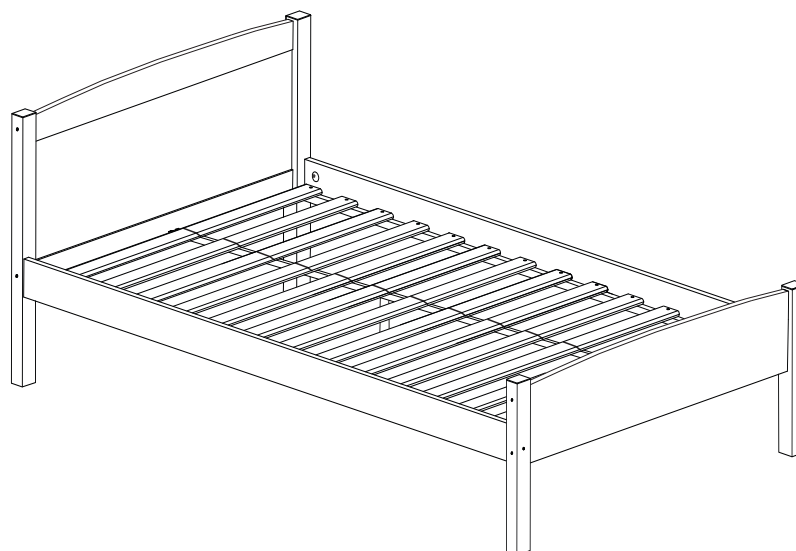
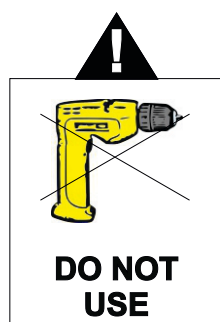

MAX WEIGHT

IMPORTANT FOR DOMESTIC USE ONLY PLEASE READ BEFORE YOU CONTINUE FURTHER CARE AND MAINTENANCE

- After unpacking this product please keep the original packaging in case it needs to be returned for any reason.
- Please ensure all fittings and parts are present before commencing with assembly.
- We recommend that you lay a blanket or sheet on the floor to avoid damage to both your floor and the product.
- We strongly recommend that you keep children away from your work area.
- Assemble this product as close to its final position as possible.
- Never drag or push products as this could cause damage to the joints making it inferior.
- Do not drag or push items across your furniture as this may cause the surface to scratch.
- Do not place this product next to a radiator or in direct sunlight.
- Wood is a natural product and may expand if subjected to damp and may shrink or crack if subjected to heat. Therefore it is recommended that room temperature is maintained, with no sudden temperature fluctuations.
- Make sure any spillage is wiped off immediately.
- Do not place hot or chilled items directly on to the surface, use a place mat or marking will occur.
- For general cleaning use a soft cotton or microfibre cloth, and do not use detergents of any kind.
- Do not place on a wet or damp floor as staining may occur to your floor.
- From time to time it may be necessary to tighten fittings, regular inspections should be carried out.

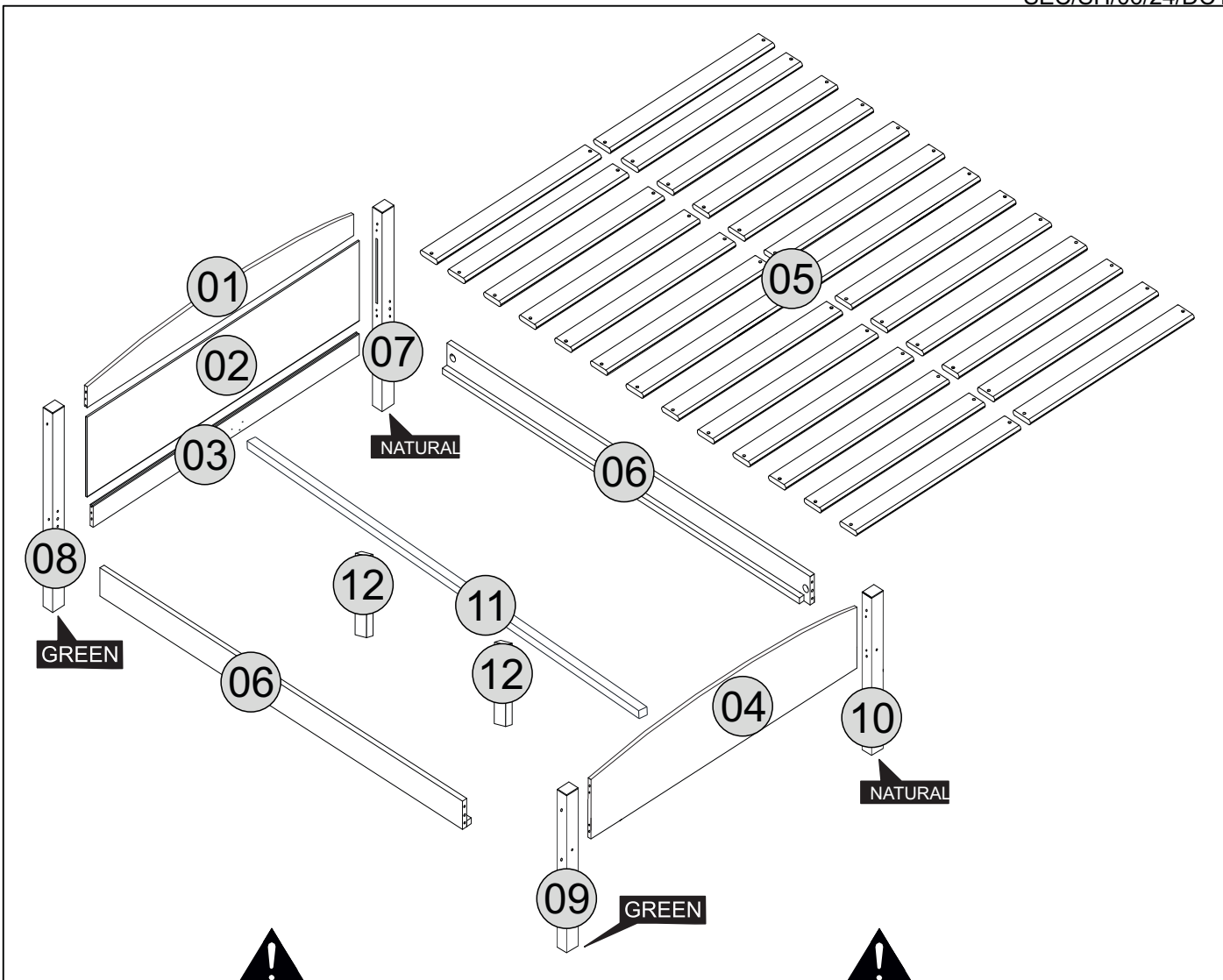

* Use of power tools to assemble this product will invalidate any claim and damage this product making it unsafe !!!
 * Please assemble on a clean soft surface to avoid damage.







* Please check contents and read the instructions before commencing assembly.
 * Assemble this product following the enclosed instructions carefully.
 * Please take care to avoid damaging panels during assembly.

Please Note:
 The below highlighted parts have been number/colour coded to help identify them during assembly.

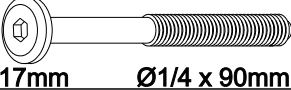
PARTS LIST

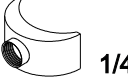
Part Number	Part Code	Part Description	Quantity	Carton
01	S200-203-001-DC1-01	Upper Crossbeam	1	1/2
02	S200-203-001-DC1-02	Large Panel	1	1/2
03	S200-203-001-DC1-03	Lower Crossbeam	1	1/2
04	S200-203-001-DC1-04	Small Panel	1	1/2
05	S200-203-001-DC1-05	Slats (02 Holes)	26	1/2
06	S200-203-001-DC1-06	Siderails	2	2/2
07	S200-203-001-DC1-07	Right Headboard Post (Natural)	1	1/2
08	S200-203-001-DC1-08	Left Headboard Post (Green)	1	1/2
09	S200-203-001-DC1-09	Left Footboard Post (Green)	1	1/2
10	S200-203-001-DC1-10	Right Footboard Post (Natural)	1	1/2
11	S200-203-001-DC1-11	Centre Support Rail	1	2/2
12	S200-203-001-DC1-12	Centre Support Leg	2	1/2

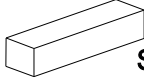
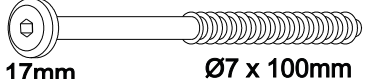
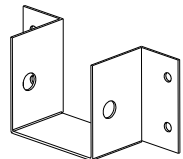
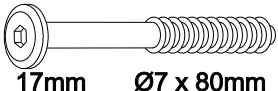
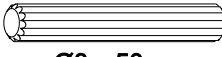
FITTINGS

A	 17mm Ø1/4 x 90mm	04	H	 Ø4,0 x 20mm	04
B	 1/4	04	I		01
C	 Ø3,5 x 30mm	52	J	 SPACER	02
D	 17mm Ø7 x 100mm	08	K		02
E	 17mm Ø7 x 80mm	02			
F	 Ø8 x 50mm	16	L	 GLUE	01
G	 Ø4,0 x 16mm	08			

TOOLS REQUIRED

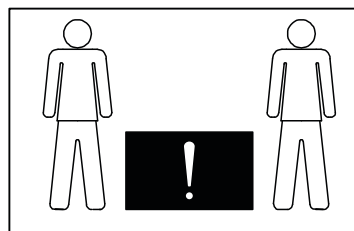
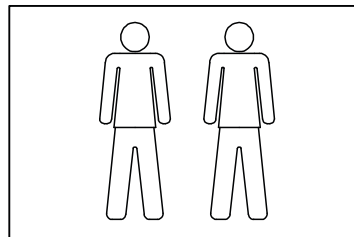
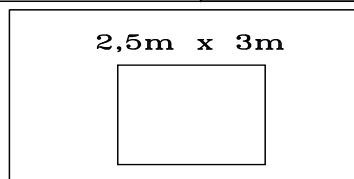
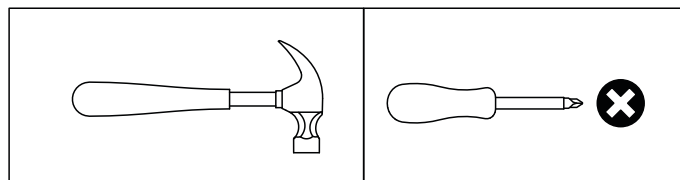

STEP 1

PARTS REQUIRED

01- UPPER CROSSBEAM x1

03- LOWER CROSSBEAM x1

07- RIGHT HEADBOARD POST (NATURAL) x1

08- LEFT HEADBOARD POST (GREEN) x1

HARDWARE REQUIRED

F  04
Ø8 x 50mm

L  01
GLUE

TOOLS REQUIRED

 **Glue must be added to the dowel holes on part 01,03,07 and 08.**

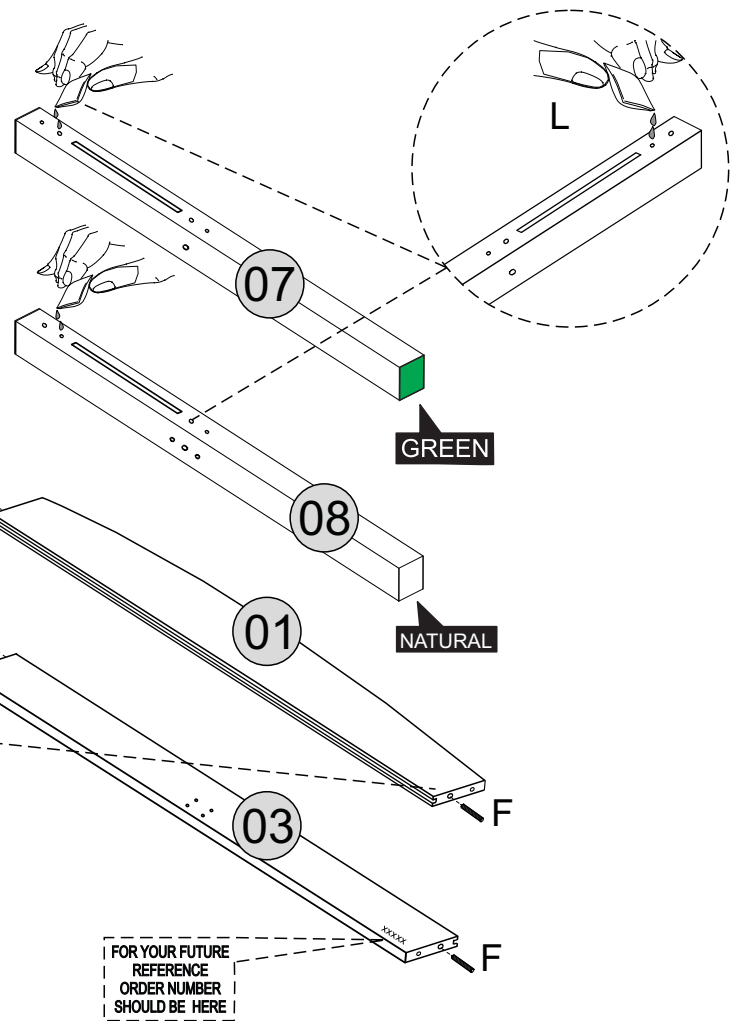
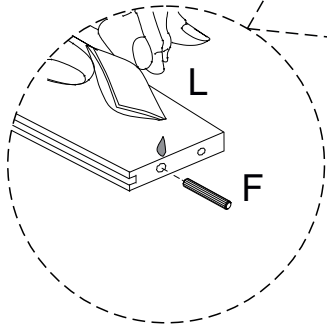

STEP 2

PARTS REQUIRED

01- UPPER CROSSBEAM x1

03- LOWER CROSSBEAM x1

07- RIGHT HEADBOARD POST (NATURAL) x1

HARDWARE REQUIRED

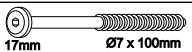
D  02
17mm Ø7 x 100mm

TOOLS REQUIRED

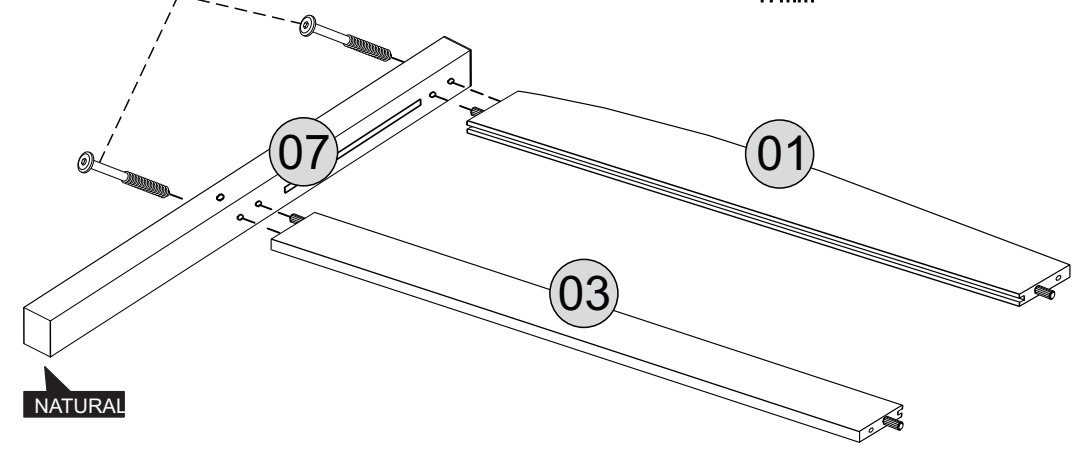
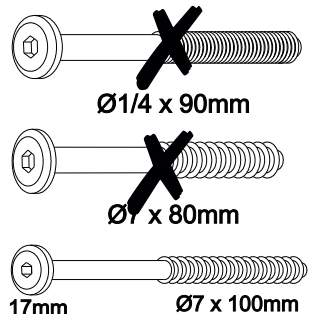
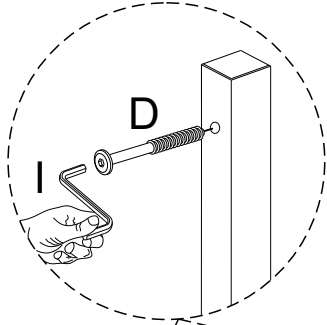

 **Please assemble on a clean soft surface to avoid damage.**

STEP 3

PARTS REQUIRED

02- LARGE PANEL x1

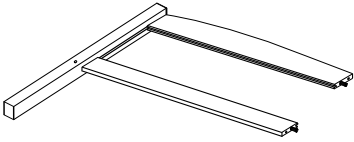

HARDWARE REQUIRED

TOOLS REQUIRED

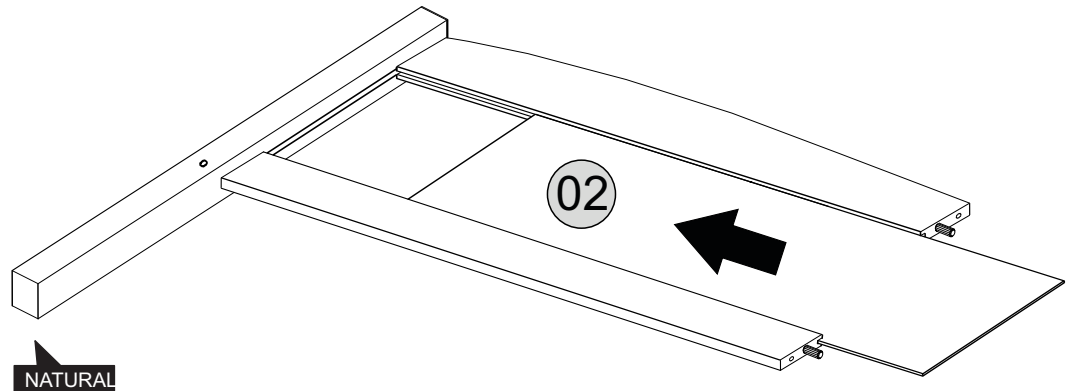

!
Please assemble on a clean soft surface to avoid damage.

STEP 4

PARTS REQUIRED

08- LEFT HEADBOARD POST (GREEN) x1

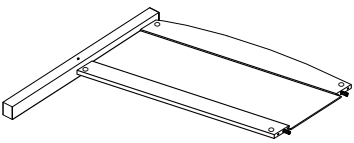

HARDWARE REQUIRED

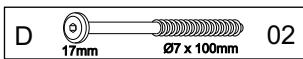

TOOLS REQUIRED

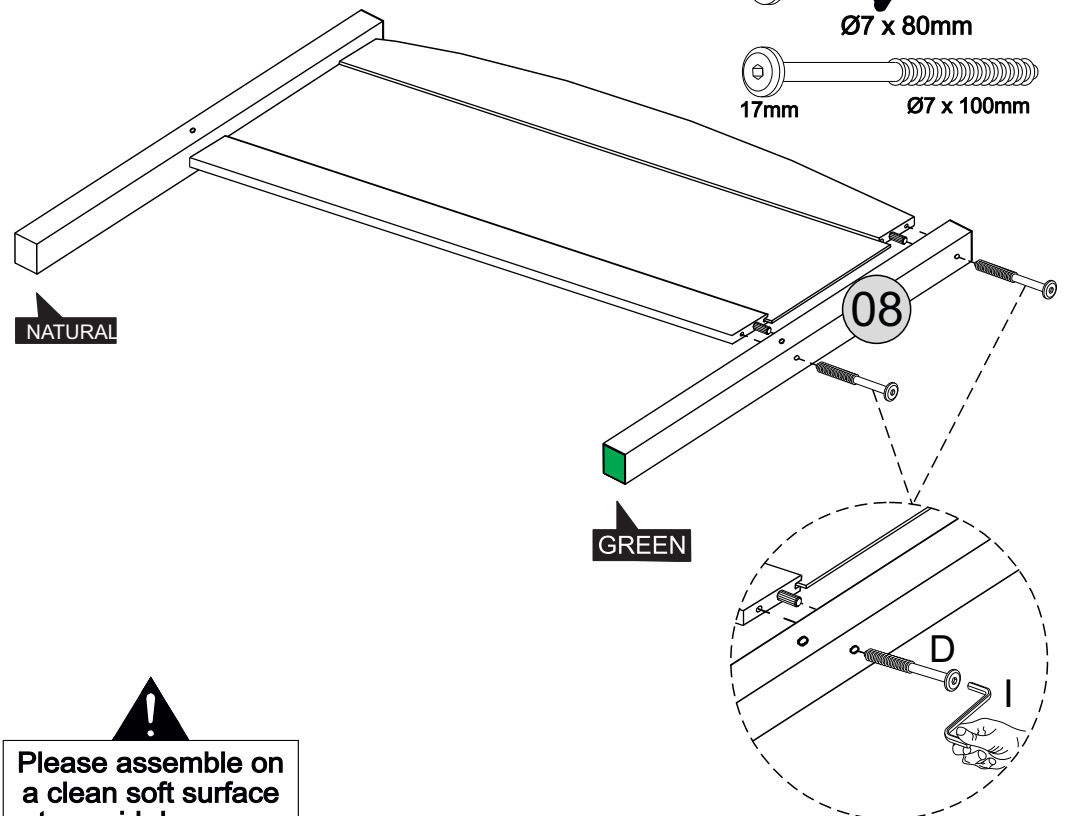



!
Please assemble on a clean soft surface to avoid damage.

STEP 5

PARTS REQUIRED

- 04- SMALL PANEL x1
- 09- LEFT FOOTBOARD POST (GREEN) x1
- 10- RIGHT HEADBOARD POST (NATURAL) x1

HARDWARE REQUIRED

- F  04
Ø8 x 50mm
- L  01
GLUE

TOOLS REQUIRED

 **Glue must be added to the dowel holes on part 04, 09 and 10.**

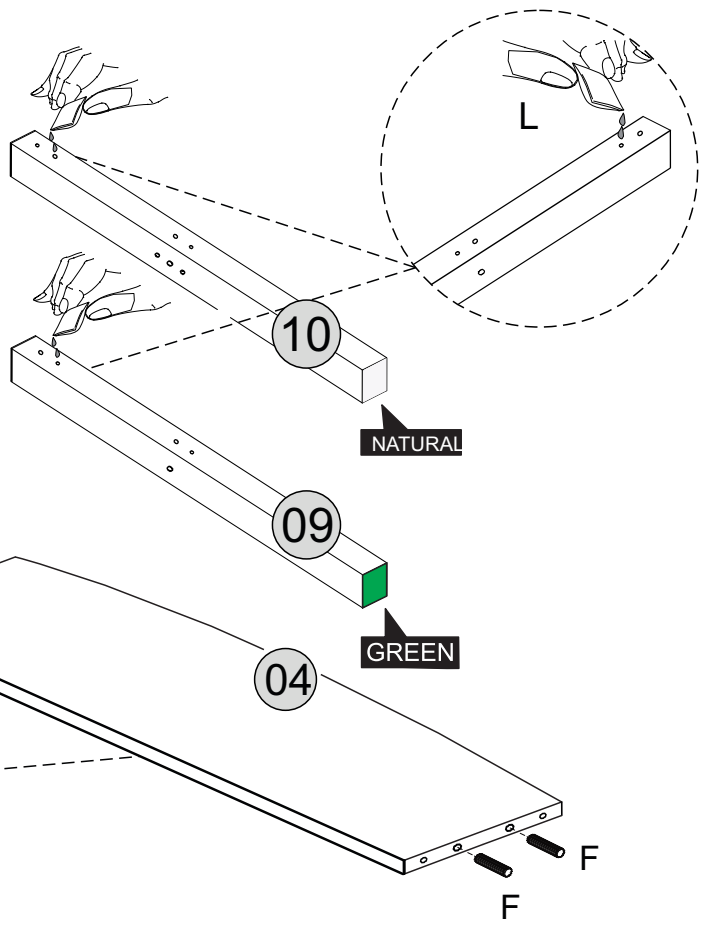
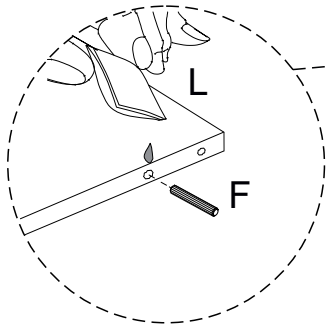

STEP 6

PARTS REQUIRED

- 04- SMALL PANEL x1
- 10- RIGHT FOOTBOARD POST (NATURAL) x1

HARDWARE REQUIRED

- D  02
17mm Ø7 x 100mm

TOOLS REQUIRED

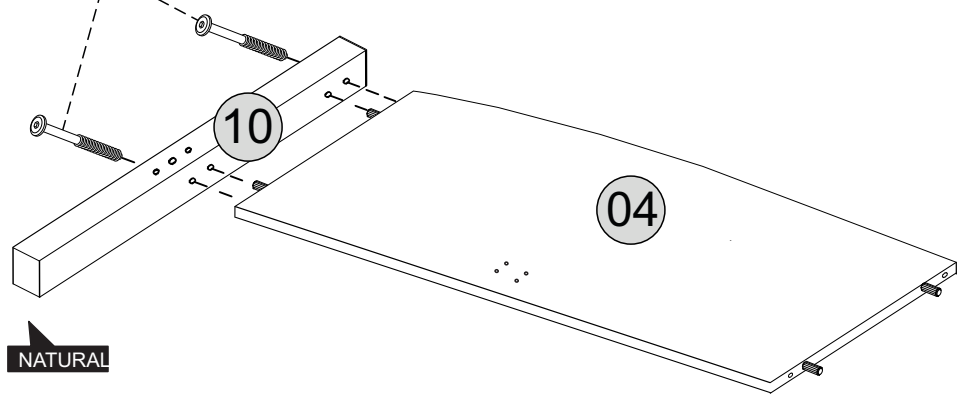
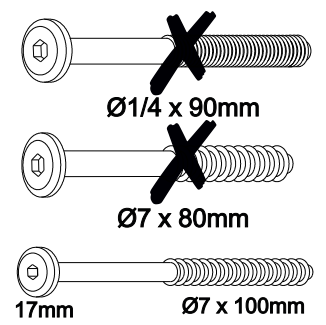
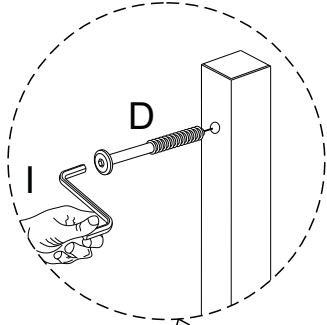

 **Please assemble on a clean soft surface to avoid damage.**

STEP 7

PARTS REQUIRED

09-LEFT FOOTBOARD POST (GREEN) x1

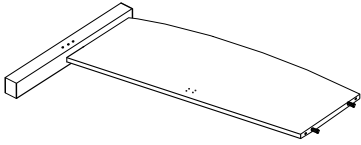

HARDWARE REQUIRED

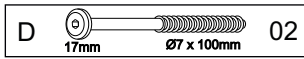

TOOLS REQUIRED

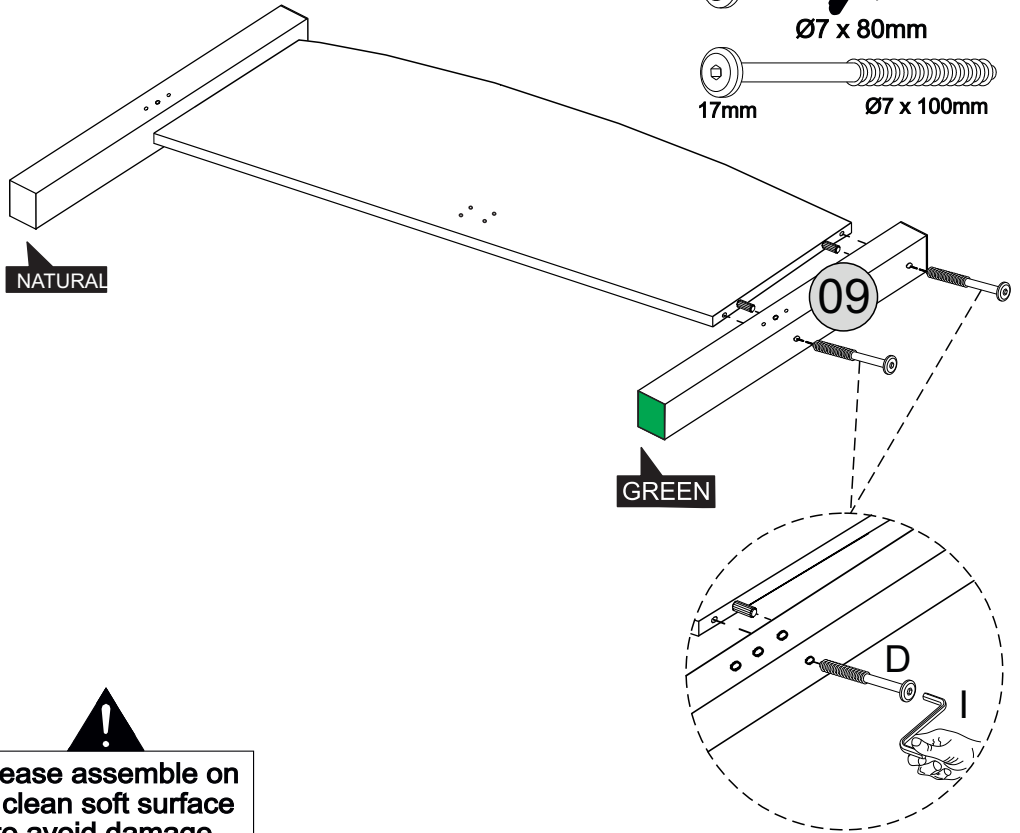
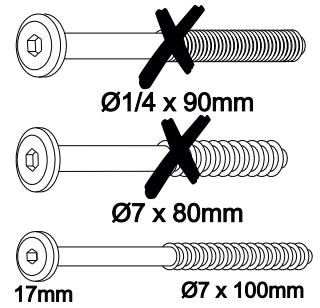

Please assemble on a clean soft surface to avoid damage.

STEP 8

PARTS REQUIRED

06- SIDERAILS x2

HARDWARE REQUIRED



TOOLS REQUIRED

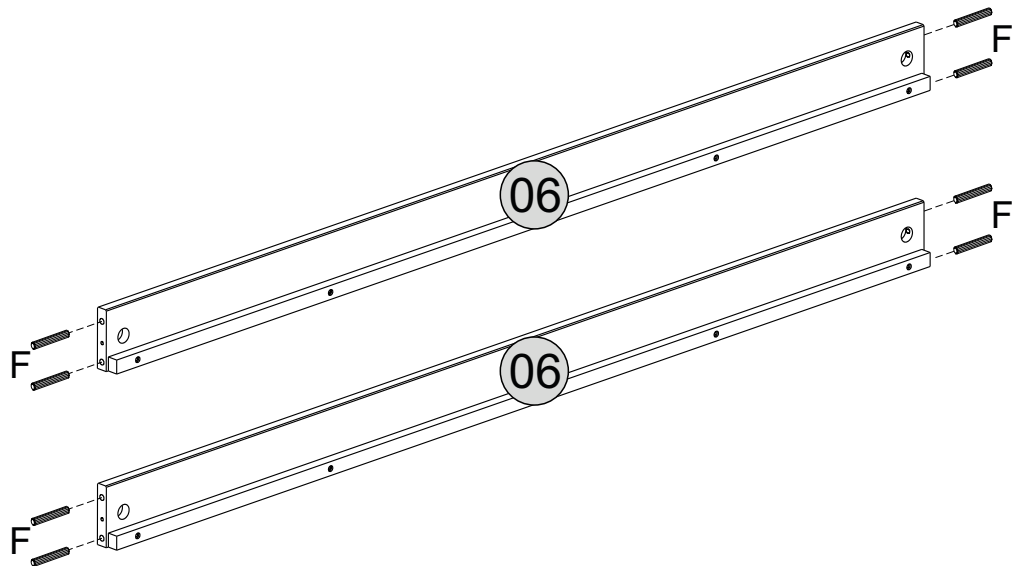

STEP 9

PARTS REQUIRED

06- SIDERAILS x2

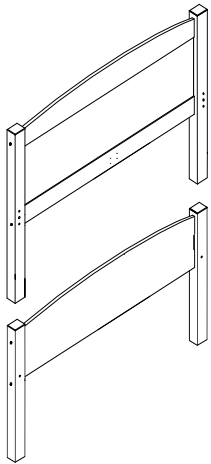

HARDWARE REQUIRED

A  04

B  04

TOOLS REQUIRED

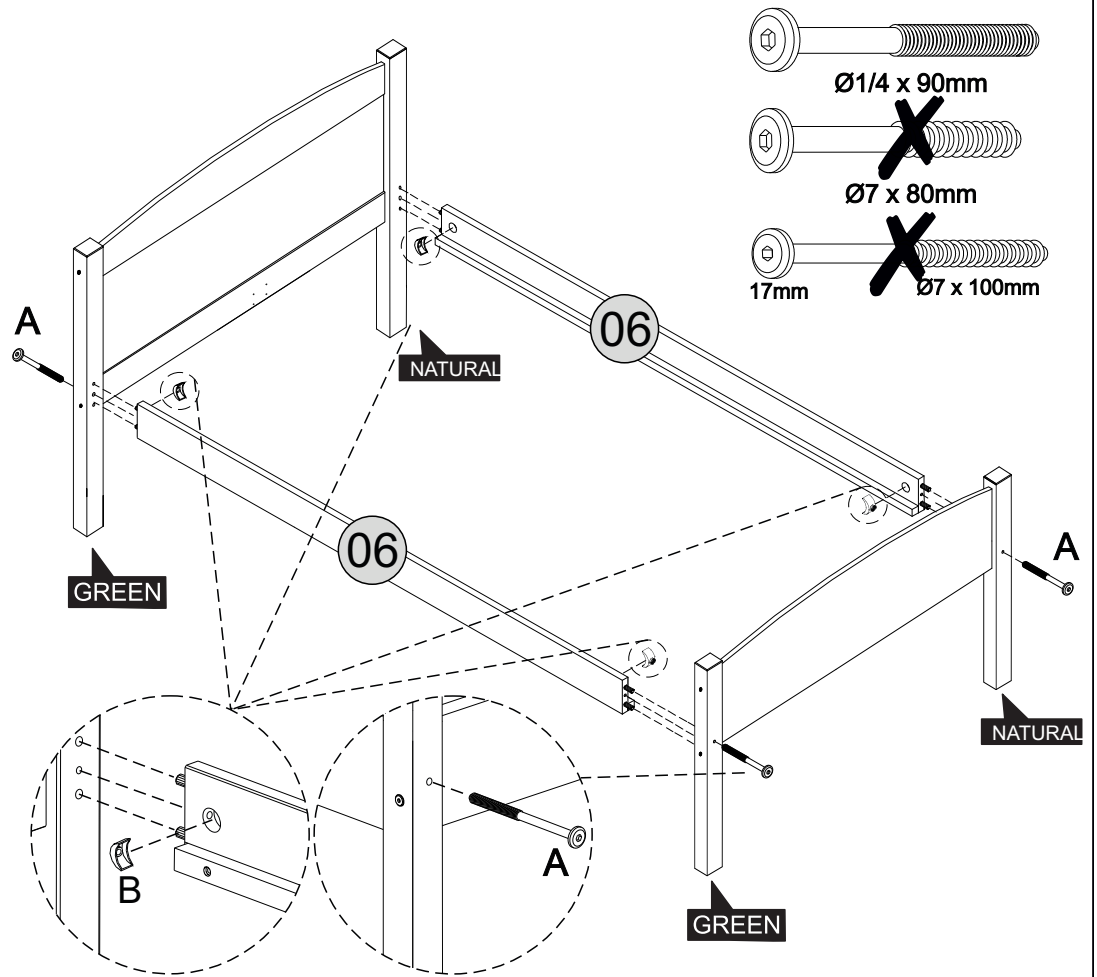
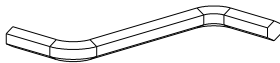

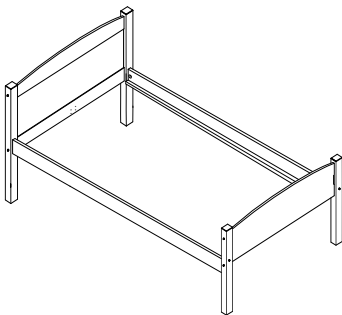

STEP 10

PARTS REQUIRED



HARDWARE REQUIRED

G  08

K  02

TOOLS REQUIRED

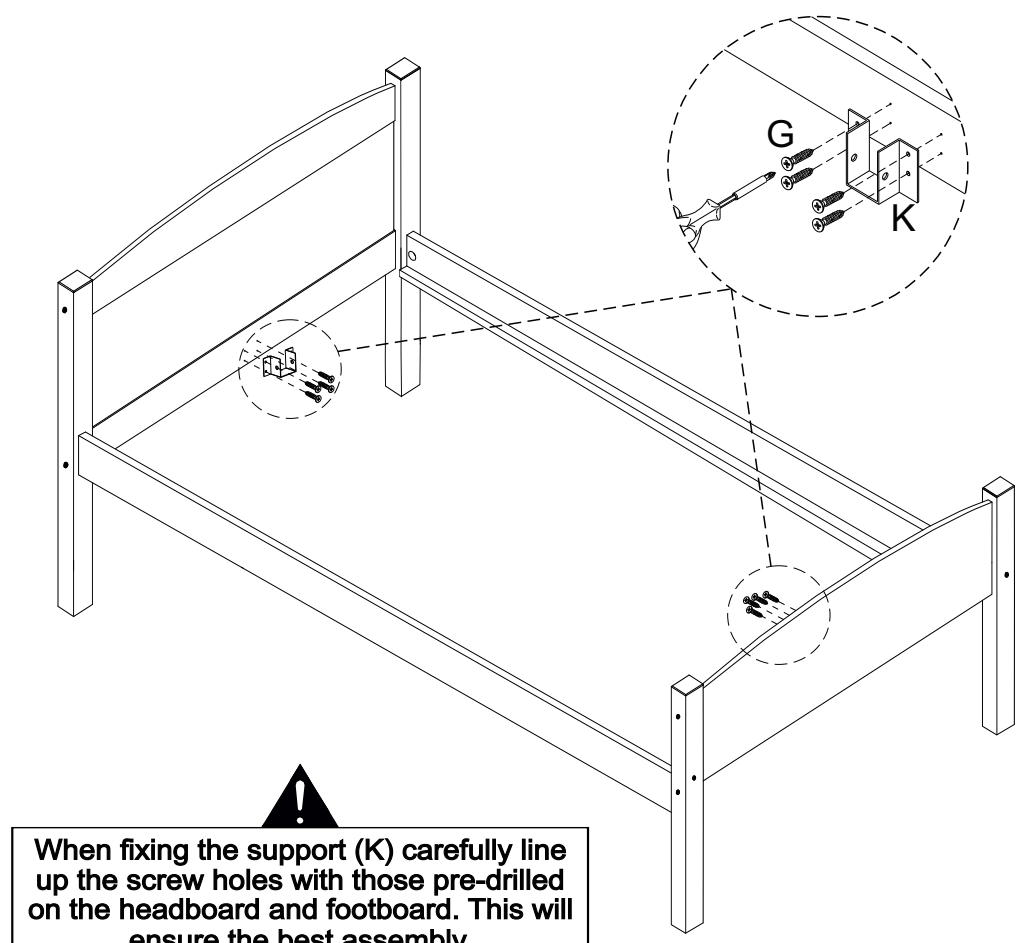
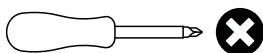

When fixing the support (K) carefully line up the screw holes with those pre-drilled on the headboard and footboard. This will ensure the best assembly.

STEP 11

PARTS REQUIRED

11- CENTRE SUPPORT RAIL x1

12- CENTRE SUPPORT LEG x2

HARDWARE REQUIRED

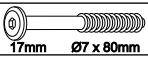
E  02
17mm Ø7 x 80mm

TOOLS REQUIRED

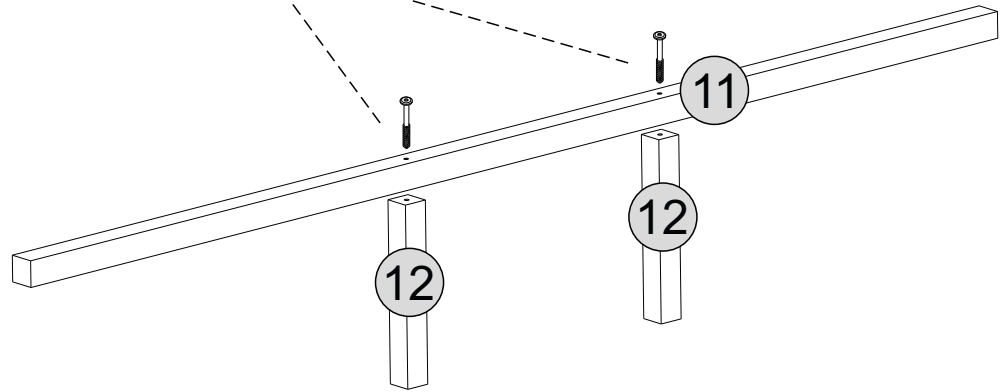
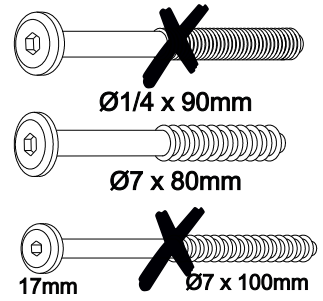
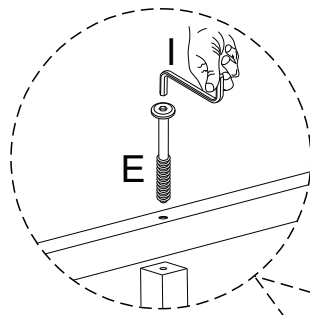

STEP 12

PARTS REQUIRED

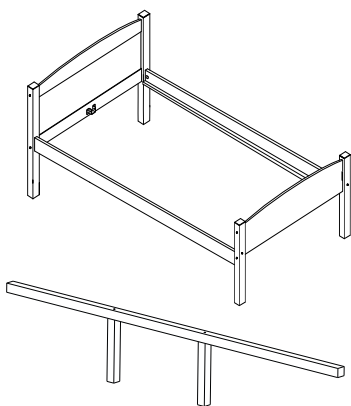

HARDWARE REQUIRED

H  04
Ø4,0 x 20mm

TOOLS REQUIRED

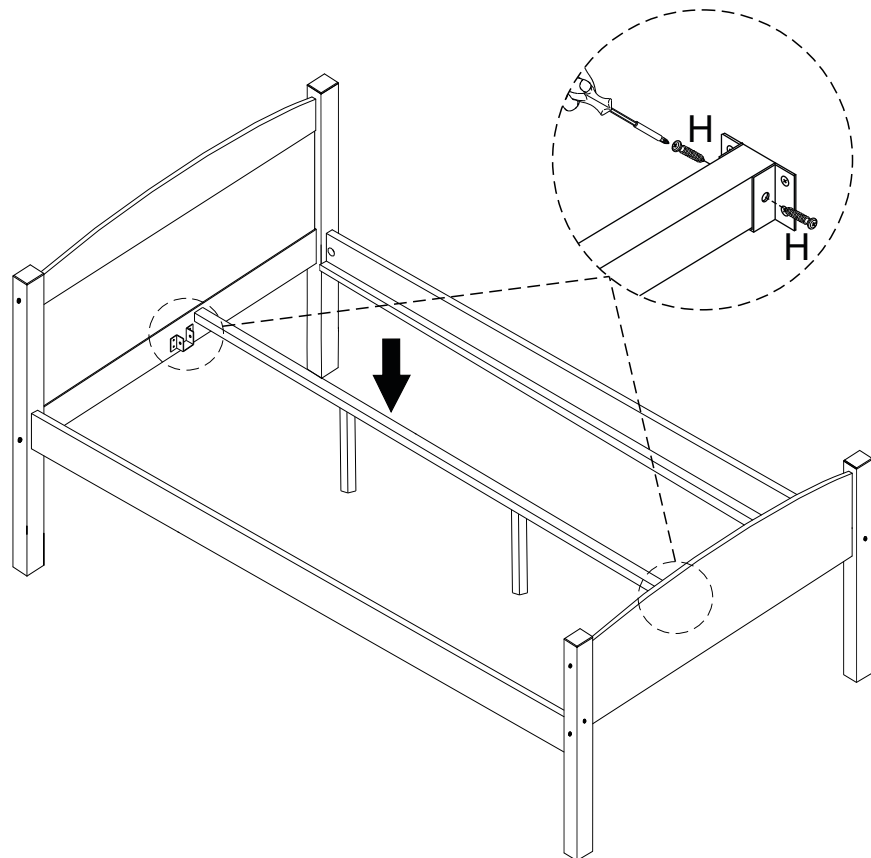

STEP 13

PARTS REQUIRED

05- SLATS (02 HOLES) x26

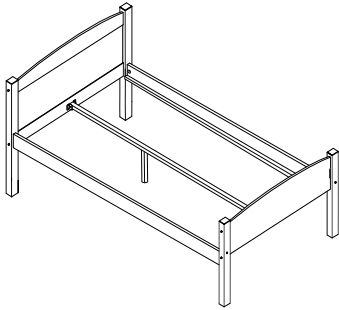

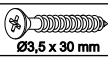

HARDWARE REQUIRED

C  52
Ø3,5 x 30 mm

J  02
SPACER

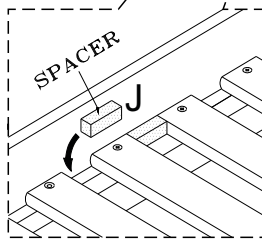
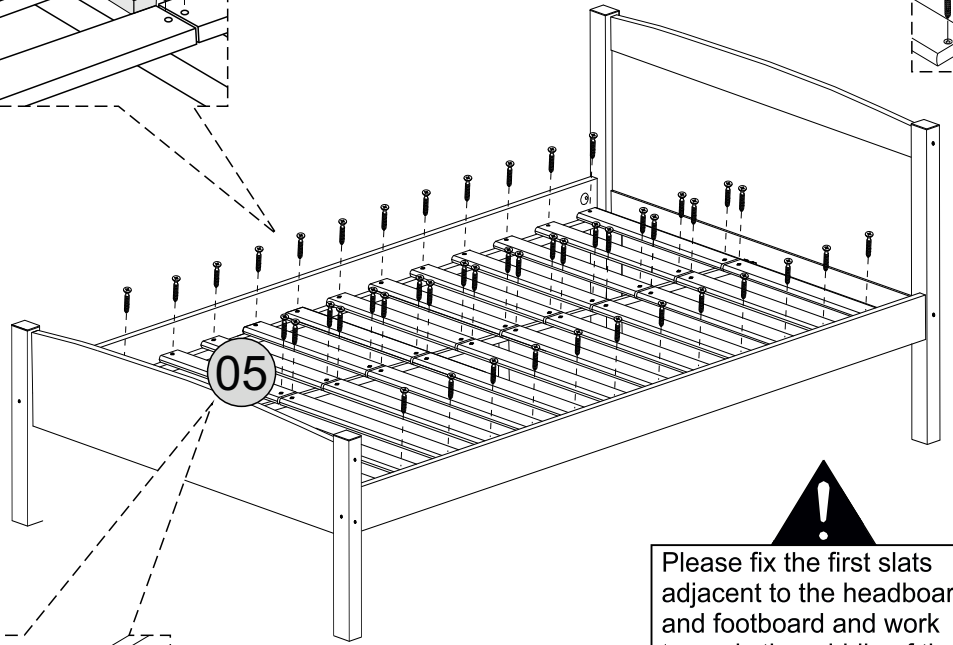
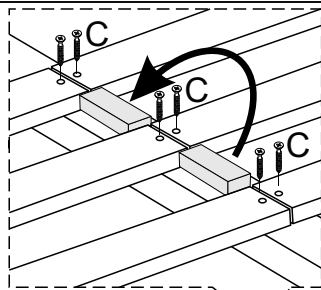
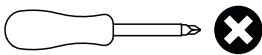
TOOLS REQUIRED



Please fix the first slats adjacent to the headboard and footboard and work towards the middle of the bed using the spacer (J) as shown to ensure correct spacing. Fix all the slats to one siderail first then push the second siderail tight against the slats and fix.

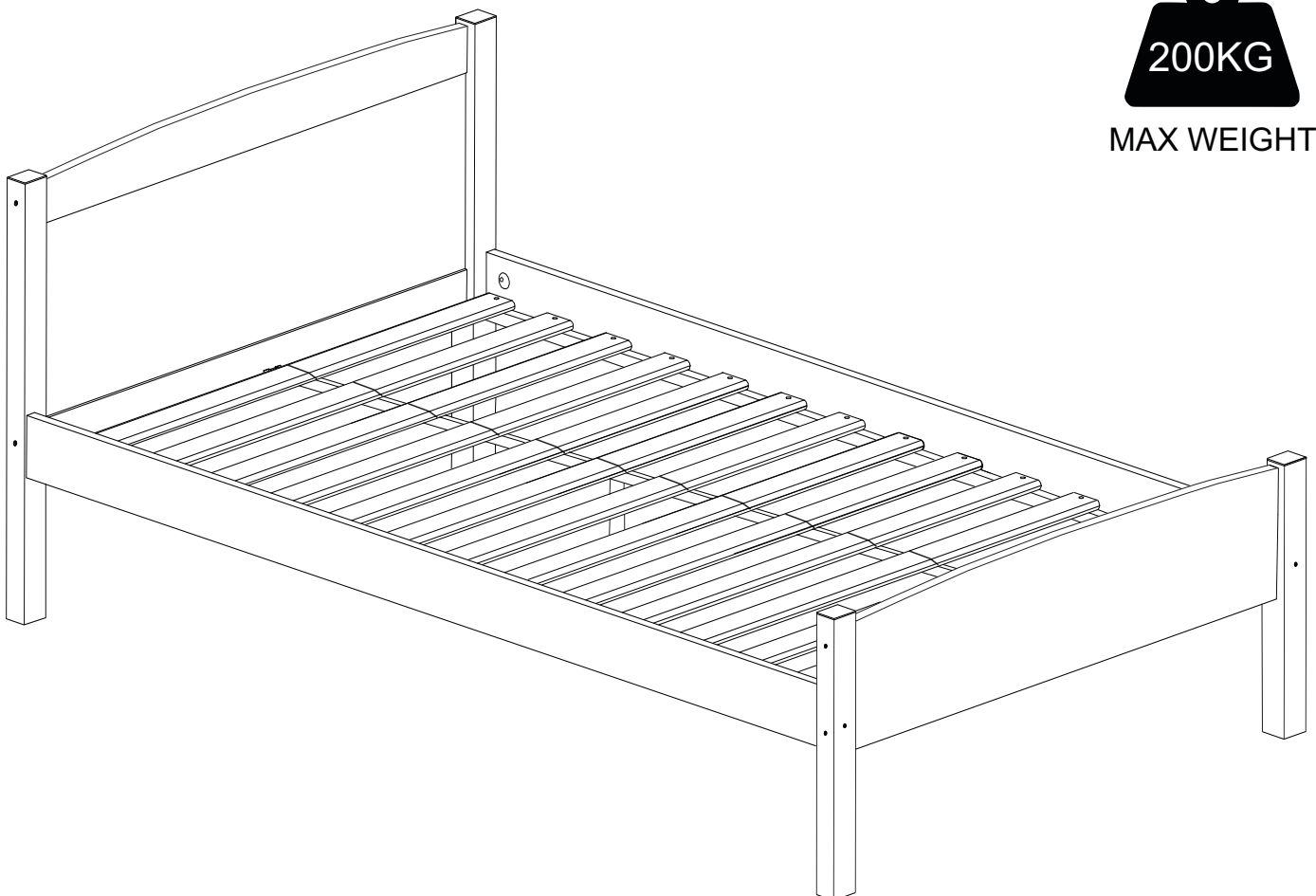

MAX WEIGHT