

LIGHT OAK RATTAN EFFECT

SANTANA 4'6 BED

ASSEMBLY INSTRUCTIONS

56359

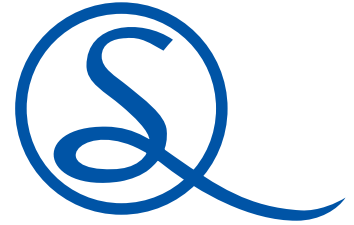
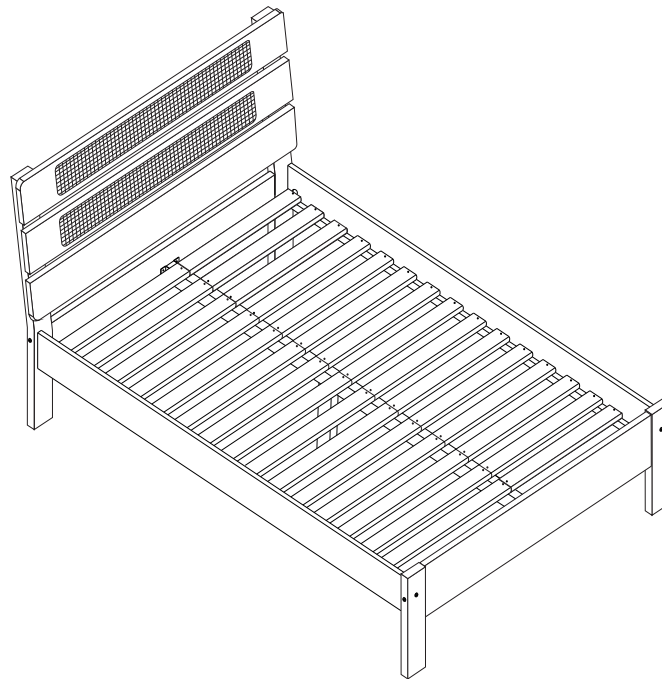
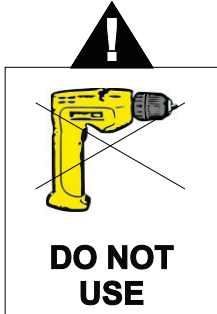

FOR DOMESTIC USE ONLY

IMPORTANT

PLEASE READ BEFORE YOU CONTINUE FURTHER

CARE AND MAINTENANCE

After unpacking this product please keep the original packaging in case it needs to be returned for any reason.

- Please ensure all fittings and parts are present before commencing with assembly.
- We recommend that you lay a blanket or sheet on the floor to avoid damage to both your floor and the product.
- We strongly recommend that you keep children away from your work area.
- Assemble this product as close to its final position as possible.
- Never drag or push products as this could cause damage to the joints making it inferior.
- Do not place this product next to a radiator or in direct sunlight.
- Wood is a natural product and may expand if subjected to damp and may shrink or crack if subjected to heat. Therefore it is recommended that room temperature is maintained, with no sudden temperature fluctuations.
- Make sure any spillage is wiped off immediately.
- Do not place hot or chilled items directly on to the surface, use a place mat or marking will occur.
- For general cleaning use a duster, and do not use detergents of any kind. However, the surface will need to be retreated from time to time. This can be done by using block wax (unperfumed) and rubbing it over the whole item.
- From time to time it may be necessary to tighten fittings, regular inspections should be carried out.

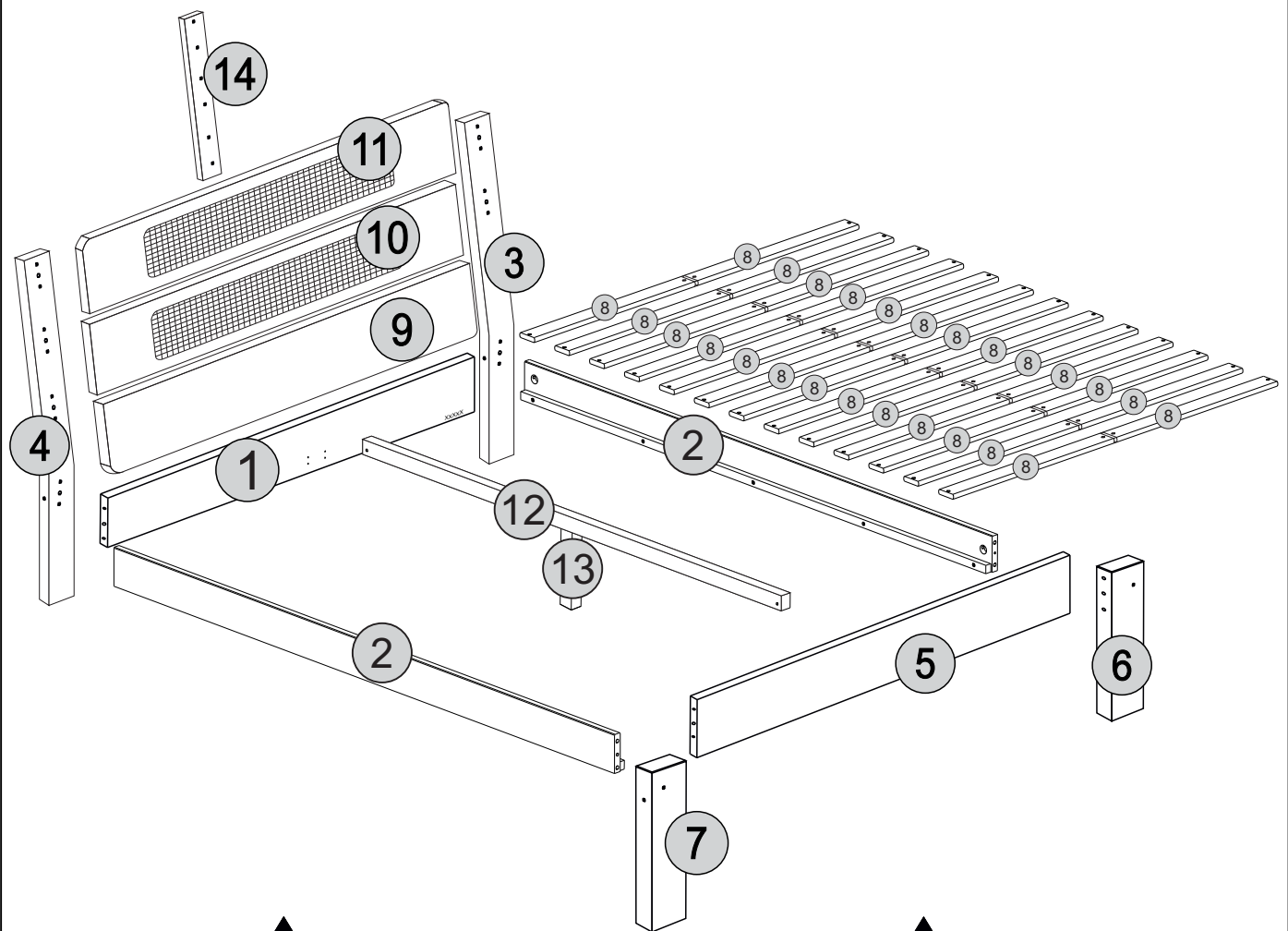









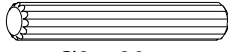

* Use of power tools to assemble this product will invalidate any claim and damage this product making it unsafe !!!
* Please assemble on a clean soft surface to avoid damage.

* Please check contents and read the instructions before commencing assembly.
* Assemble this product following the enclosed instructions carefully.
* Please take care to avoid damaging panels during assembly.

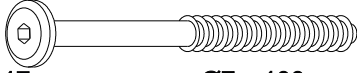
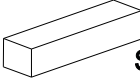
PARTS LIST

Part Number	Part Code	Part Description	Quantity	Carton
1	S200-203-117-DC1-01	Headboard Panel	1	1/2
2	S200-203-117-DC1-02	Siderail	2	2/2
3	S200-203-117-DC1-03	Headboard Right Post	1	1/2
4	S200-203-117-DC1-04	Headboard Left Post (Green)	1	1/2
5	S200-203-117-DC1-05	Footboard Panel	1	1/2
6	S200-203-117-DC1-06	Footboard Right Post	1	1/2
7	S200-203-117-DC1-07	Footboard Left Post (Green)	1	1/2
8	S200-203-117-DC1-08	Slats	26	2/2
9	S200-203-117-DC1-09	Lower Headboard Panel	1	1/2
10	S200-203-117-DC1-10	Centre Headboard Panel	1	1/2
11	S200-203-117-DC1-11	Top Headboard Panel	1	1/2
12	S200-203-117-DC1-12	Centre Rail	1	2/2
13	S200-203-117-DC1-13	Centre Support Leg	1	1/2
14	S200-203-117-DC1-14	Support Headboard	1	1/2

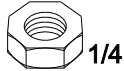
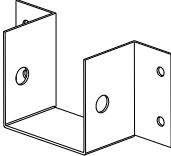
FITTINGS

A	 $\text{Ø}8 \times 50\text{mm}$	16	H		01
B	 17mm $\text{Ø} 1/4 \times 80\text{mm}$	04	I	 $\text{Ø}8 \times 30\text{mm}$	06
C	 1/4	04	J	 $5,0 \times 50\text{mm}$	12
D	 17mm $\text{Ø}7 \times 100\text{mm}$	04	K	 SPACER	02
E	 $\text{Ø}4,0 \times 30\text{mm}$	52	L	 $\text{Ø}3,5 \times 25\text{mm}$	06
F	 17mm $\text{Ø}1/4 \times 60\text{mm}$	02	M	 1/4	02
G		02	N	 17mm $\text{Ø}7 \times 90\text{mm}$	01
			O	 $\text{Ø}4,0 \times 16\text{mm}$	08

TOOLS REQUIRED

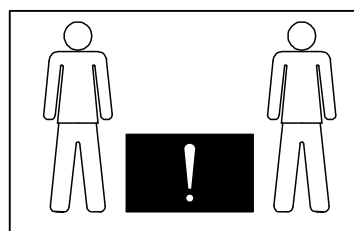
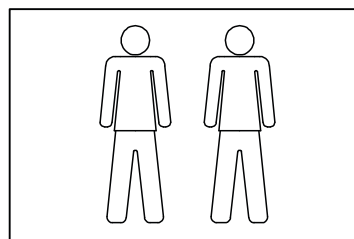
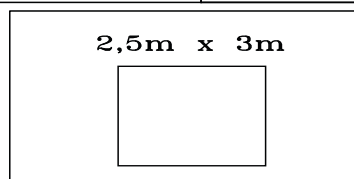
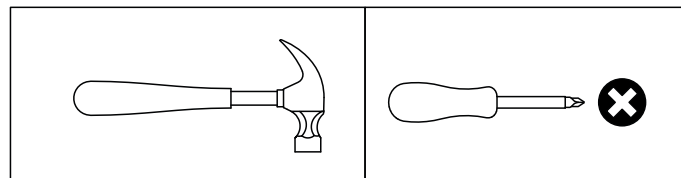

STEP 1

PARTS REQUIRED

1 - HEADBOARD PANEL	x1
2 - SIDERAIL	x2
5 - FOOTBOARD PANEL	x1

HARDWARE REQUIRED

A		16
---	---	----

TOOLS REQUIRED



Ø8 x 50mm



Ø8 x 30mm

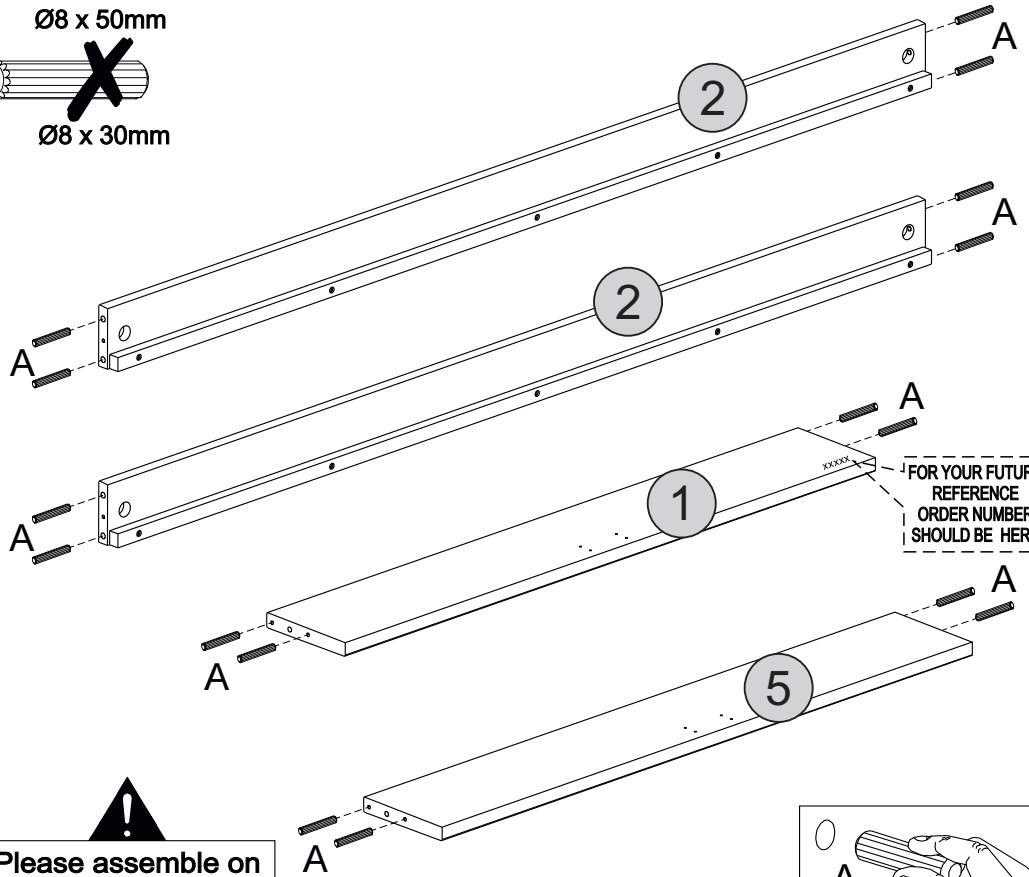

FOR YOUR FUTURE REFERENCE ORDER NUMBER SHOULD BE HERE

 Please assemble on a clean soft surface to avoid damage.

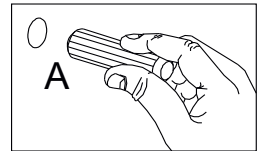

STEP 2

PARTS REQUIRED

3 - HEADBOARD RIGHT POST	x1
4 - HEADBOARD LEFT POST (GREEN)	x1

HARDWARE REQUIRED

I		06
---	---	----

TOOLS REQUIRED



Ø8 x 50mm

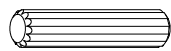

Ø8 x 30mm

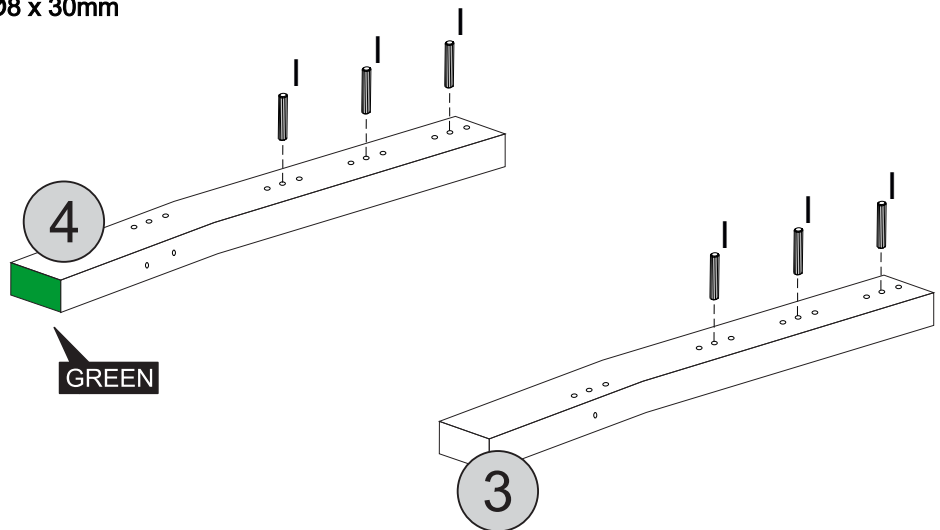

GREEN

 Please assemble on a clean soft surface to avoid damage.

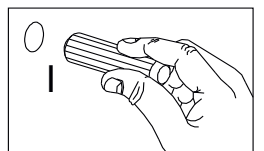

STEP 3

PARTS REQUIRED

- 1 - HEADBOARD PANEL x1
- 3 - HEADBOARD RIGHT POST x1
- 4 - HEADBOARD LEFT POST (GREEN) x1

HARDWARE REQUIRED

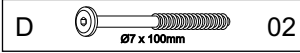

TOOLS REQUIRED

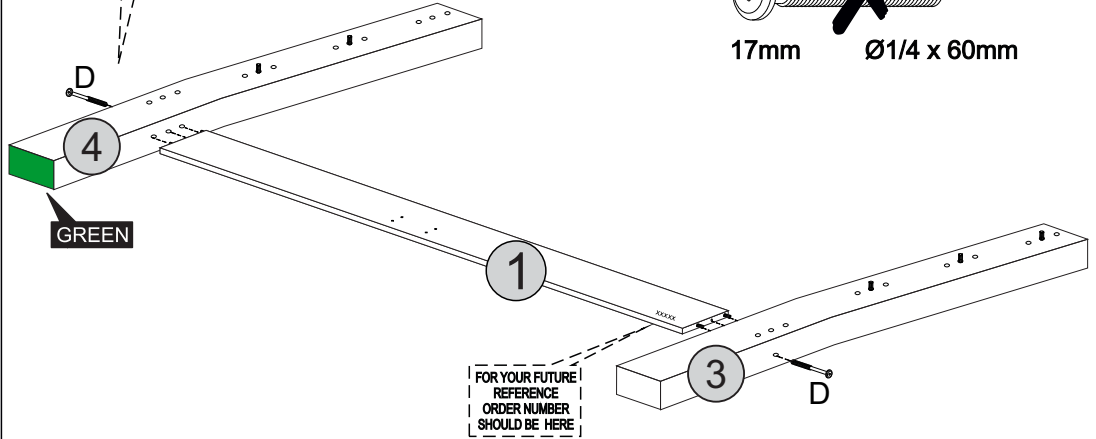
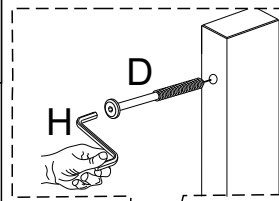
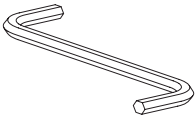

- 17mm $\text{\O}7$ x 100mm
- 17mm ~~$\text{\O}7$ x 90mm~~
- 17mm ~~$\text{\O}1/4$ x 80mm~~
- 17mm ~~$\text{\O}1/4$ x 60mm~~

Please assemble on a clean soft surface to avoid damage.

STEP 4

PARTS REQUIRED

- 5 - FOOTBOARD PANEL x1
- 6 - FOOTBOARD RIGHT POST x1
- 7 - FOOTBOARD LEFT POST (GREEN) x1

HARDWARE REQUIRED

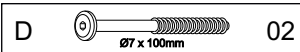

TOOLS REQUIRED

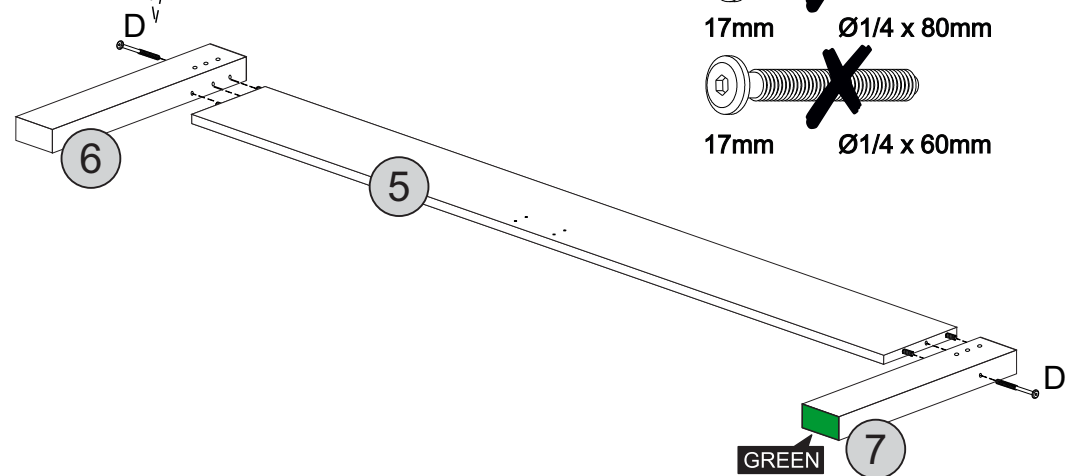
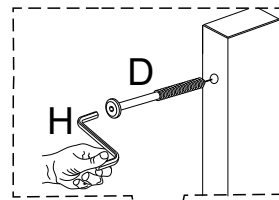
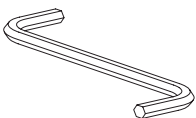

- 17mm $\text{\O}7$ x 100mm
- 17mm ~~$\text{\O}7$ x 90mm~~
- 17mm ~~$\text{\O}1/4$ x 80mm~~
- 17mm ~~$\text{\O}1/4$ x 60mm~~

Please assemble on a clean soft surface to avoid damage.

STEP 5

PARTS REQUIRED

- 9 - LOWER HEADBOARD PANEL x1
- 10 - CENTRE HEADBOARD PANEL x1
- 11 - HEAD & FOOTBOARD TOP PANEL x1

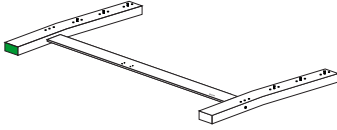

HARDWARE REQUIRED

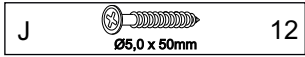

TOOLS REQUIRED

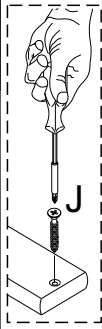
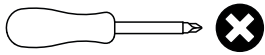

Ø5,0 x 50mm



Ø4,0 x 30mm

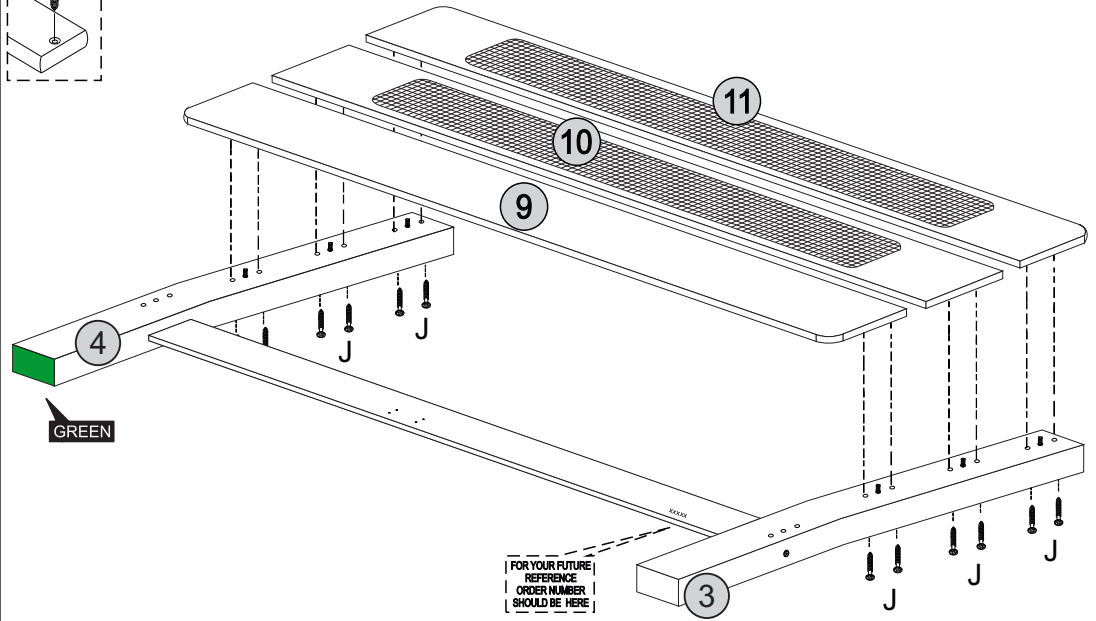

STEP 6

PARTS REQUIRED

- 2- SIDERAIL x2

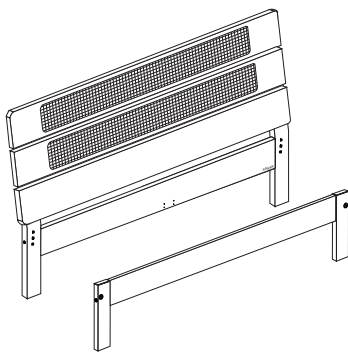

HARDWARE REQUIRED

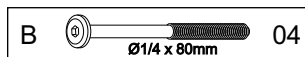

TOOLS REQUIRED

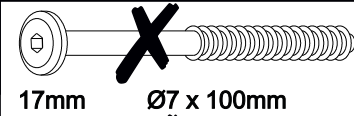
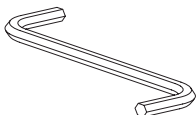

17mm Ø7 x 100mm



17mm Ø7 x 90mm

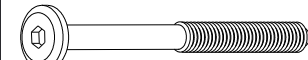

17mm Ø1/4 x 80mm

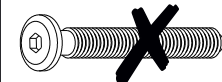

17mm Ø1/4 x 60mm

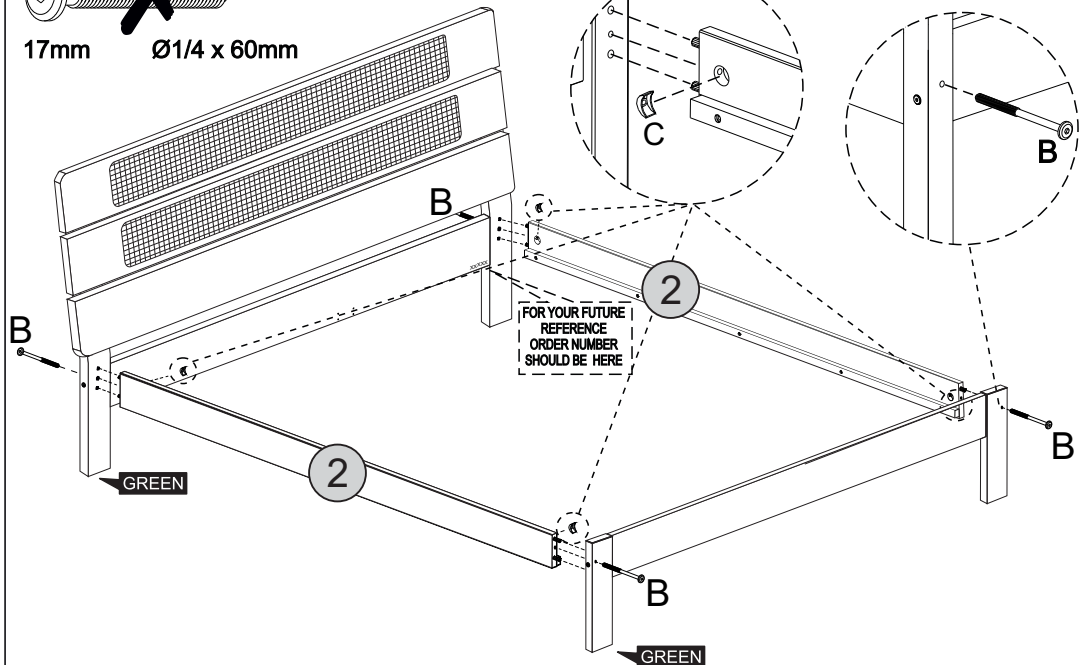

STEP 7

PARTS REQUIRED

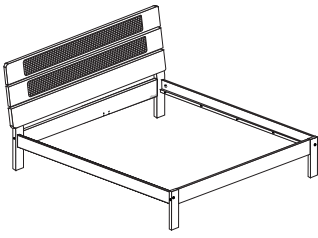

HARDWARE REQUIRED

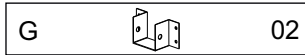

TOOLS REQUIRED

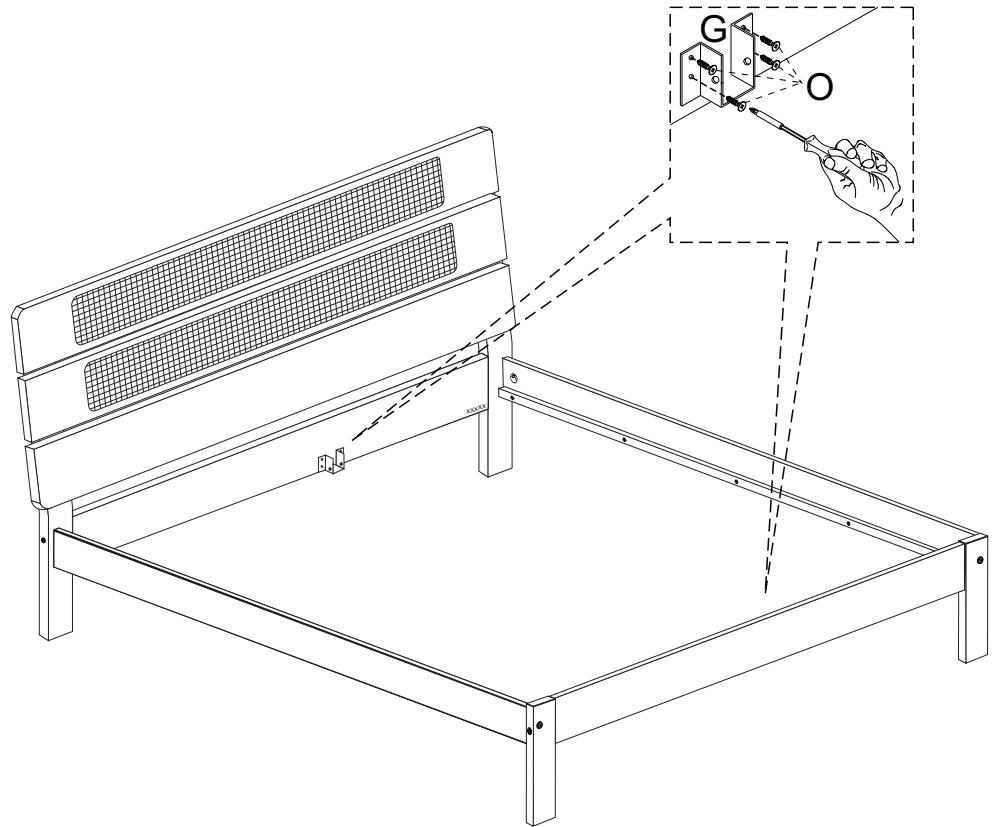
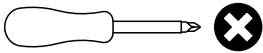

STEP 8

PARTS REQUIRED

12 - CENTRE RAIL	x1
------------------	----

13 - CENTRE SUPPORT LEG	x1
-------------------------	----

HARDWARE REQUIRED

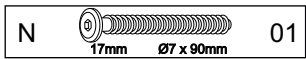

TOOLS REQUIRED

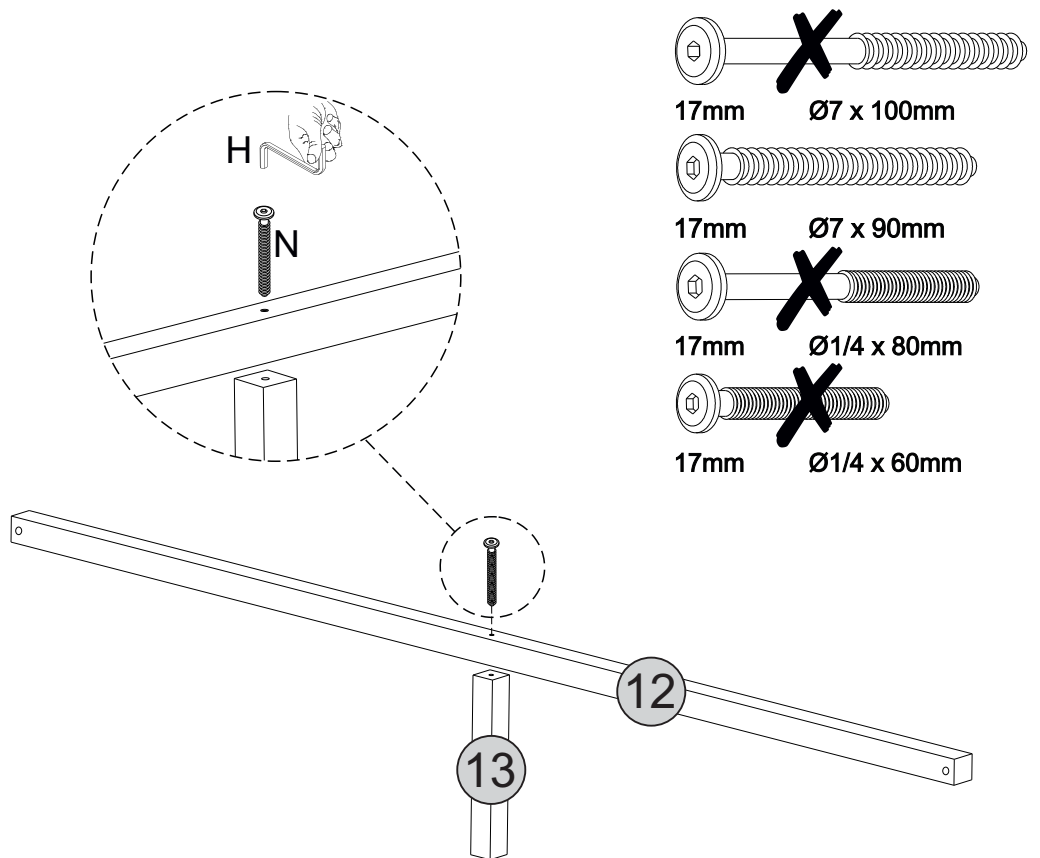
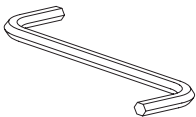

STEP 9

PARTS REQUIRED

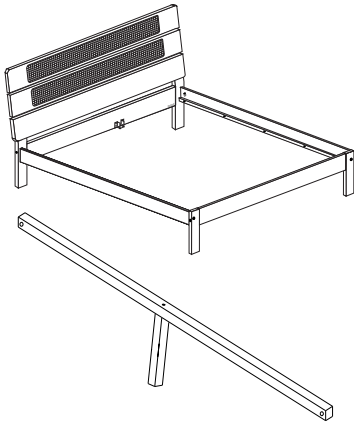

HARDWARE REQUIRED

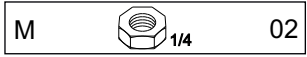
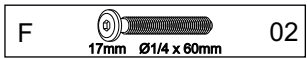

TOOLS REQUIRED

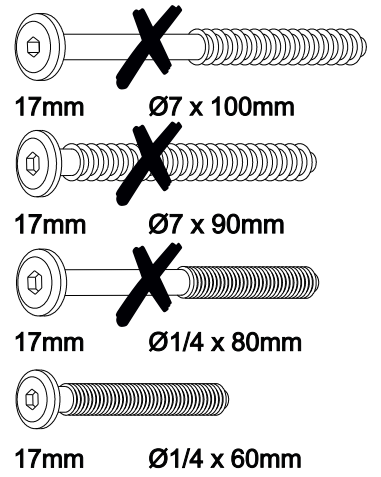
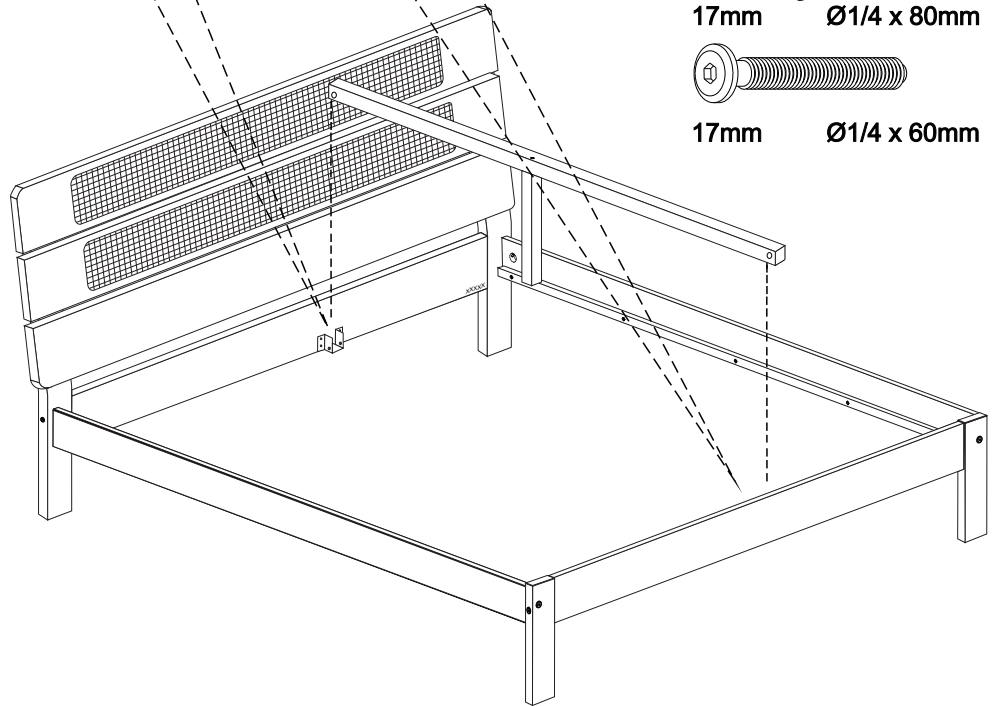
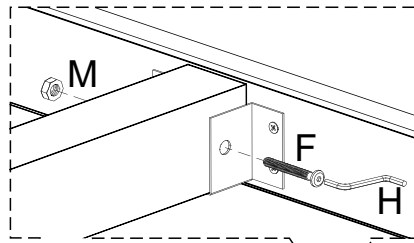
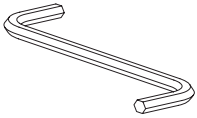

STEP 10

PARTS REQUIRED

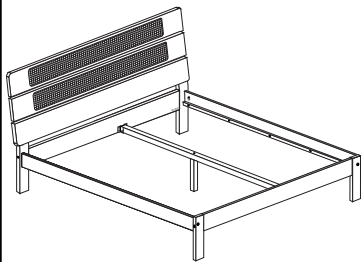

HARDWARE REQUIRED

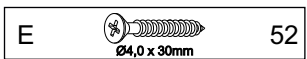

TOOLS REQUIRED

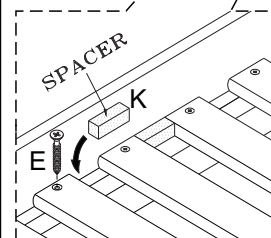
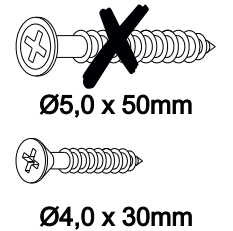
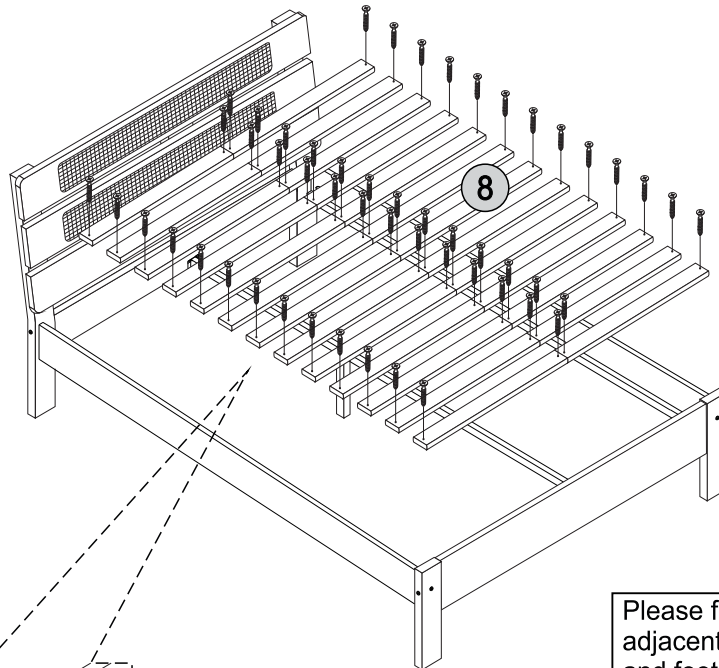
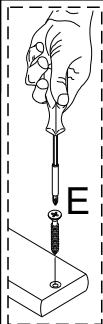
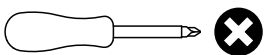

!
Please fix the first slats adjacent to the headboard and footboard and work towards the middle of the bed using the spacer (K) as shown to ensure correct spacing. Fix all the slats to one siderail first then push the second siderail tight against the slats and fix.

STEP 11

PARTS REQUIRED

14 -SUPPORT HEADBOARD x1

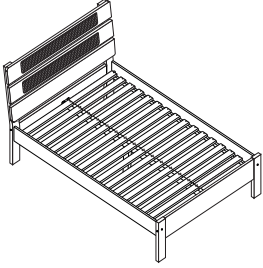

HARDWARE REQUIRED

L  Ø3,5 x 25mm 06

TOOLS REQUIRED

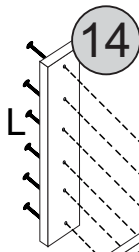
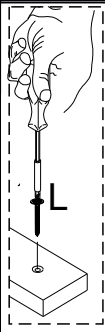
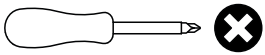

200KG
MAX WEIGHT