

# GREY OAK EFFECT MONACO 5' HIGH END BED ASSEMBLY INSTRUCTIONS

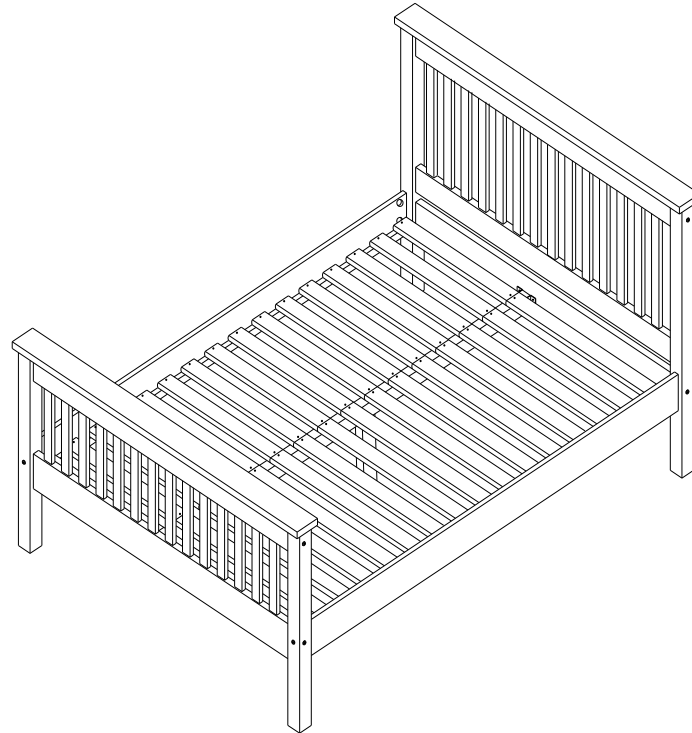

**MAX WEIGHT**

**FOR DOMESTIC USE ONLY  
IMPORTANT**

**PLEASE READ BEFORE YOU CONTINUE FURTHER**

## **CARE AND MAINTENANCE**

After unpacking this product please keep the original packaging in case it needs to be returned for any reason.

- Please ensure all fittings and parts are present before commencing with assembly.
- We recommend that you lay a blanket or sheet on the floor to avoid damage to both your floor and the product.
- We strongly recommend that you keep children away from your work area.
- Assemble this product as close to its final position as possible.
- Never drag or push products as this could cause damage to the joints making it inferior.
- Do not place this product next to a radiator or in direct sunlight.
- Wood is a natural product and may expand if subjected to damp and may shrink or crack if subjected to heat. Therefore it is recommended that room temperature is maintained, with no sudden temperature fluctuations.
- Make sure any spillage is wiped off immediately.
- Do not place hot or chilled items directly on to the surface, use a place mat or marking will occur.
- For general cleaning use a duster, and do not use detergents of any kind. However, the surface will need to be retreated from time to time. This can be done by using block wax (unperfumed) and rubbing it over the whole item.
- From time to time it may be necessary to tighten fittings, regular inspections should be carried out.

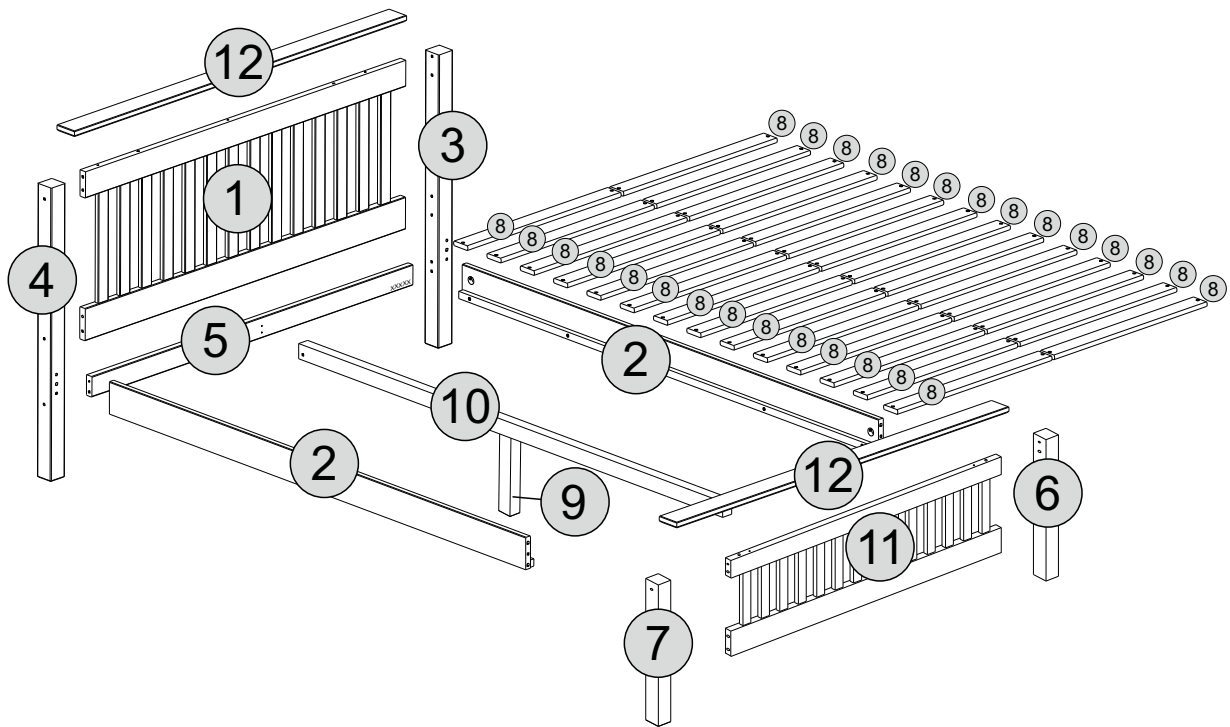









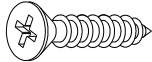
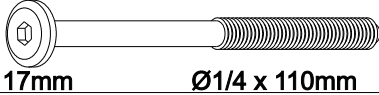
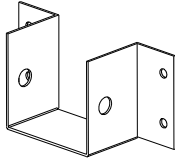

\* Use of power tools to assemble this product will invalidate any claim and damage this product making it unsafe !!!  
 \* Please assemble on a clean soft surface to avoid damage.

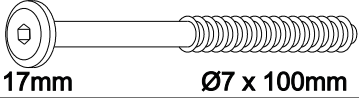
\* Please check contents and read the instructions before commencing assembly.  
 \* Assemble this product following the enclosed instructions carefully.  
 \* Please take care to avoid damaging panels during assembly.

### PARTS LIST

Part Number	Part Code	Part Description	Quantity	Carton
1	S200-204-048-DC1-01	Headboard Panel	1	1/4
2	S200-204-048-DC1-02	Siderail	2	3/4
3	S200-204-048-DC1-03	Headboard Right Post (Natural)	1	2/4
4	S200-204-048-DC1-04	Headboard Left Post (Green)	1	2/4
5	S200-204-048-DC1-05	Headboard Crossbeam	1	1/4
6	S200-204-048-DC1-06	Footboard Right Post (Natural)	1	2/4
7	S200-204-048-DC1-07	Footboard Left Post (Green)	1	2/4
8	S200-204-048-DC1-08	Slats (2 Holes)	28	4/4
9	S200-204-048-DC1-09	Centre Support Leg	1	3/4
10	S200-204-048-DC1-10	Centre Rail	1	3/4
11	S200-204-048-DC1-11	Footboard Panel	1	1/4
12	S200-204-048-DC1-12	Top Crossbeam	2	3/4

### FITTINGS

A	 Ø8 x 50mm	22	H	 Ø4,0 x 16mm	08
B	 17mm Ø1/4 x 110mm	04	I		02
C	 1/4	04			
D	 17mm Ø7 x 100mm	10	J	 17mm Ø1/4 x 60mm	02
E	 Ø4,0 x 30mm	56	K	 1/4	02
F		01	L	 Ø3,5 x 30mm	06
G	 SPACER 87mm	02	M	 17mm Ø7 x 90mm	01

### TOOLS REQUIRED

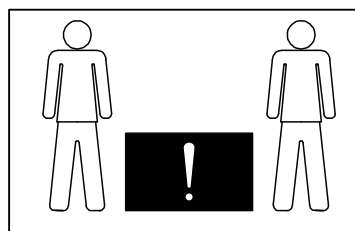
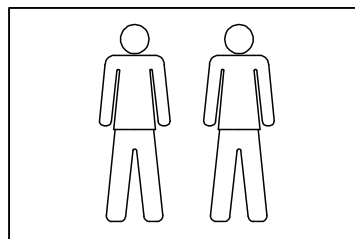
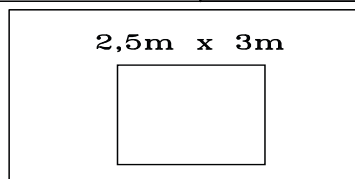
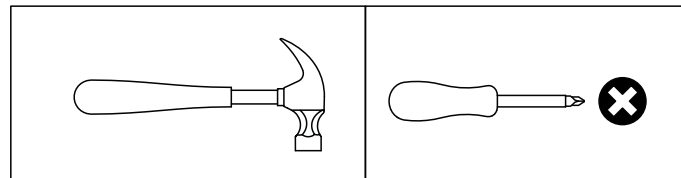

# STEP 1

## PARTS REQUIRED

2 - SIDERAIL x2

5 - HEADBOARD CROSSBEAM x1

## HARDWARE REQUIRED

A  10  
Ø8 x 50mm

## TOOLS REQUIRED

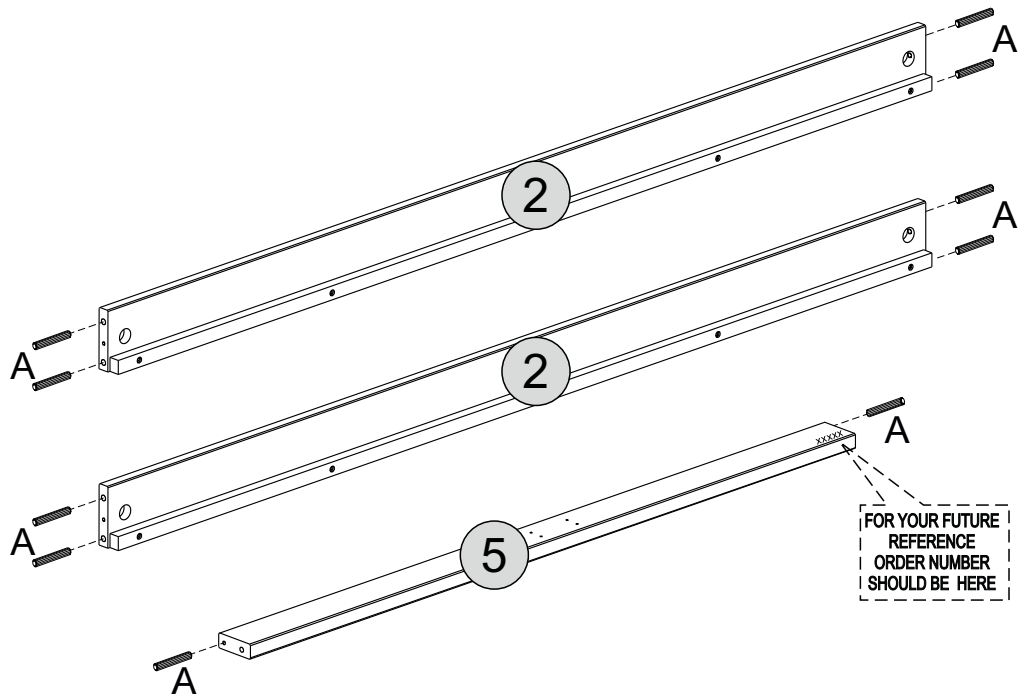

 Please assemble on a clean soft surface to avoid damage.

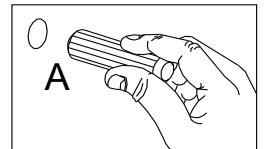

# STEP 2

## PARTS REQUIRED

1 - HEADBOARD PANEL x1

11- FOOTBOARD PANEL x1

## HARDWARE REQUIRED

A  12  
Ø8 x 50mm

## TOOLS REQUIRED

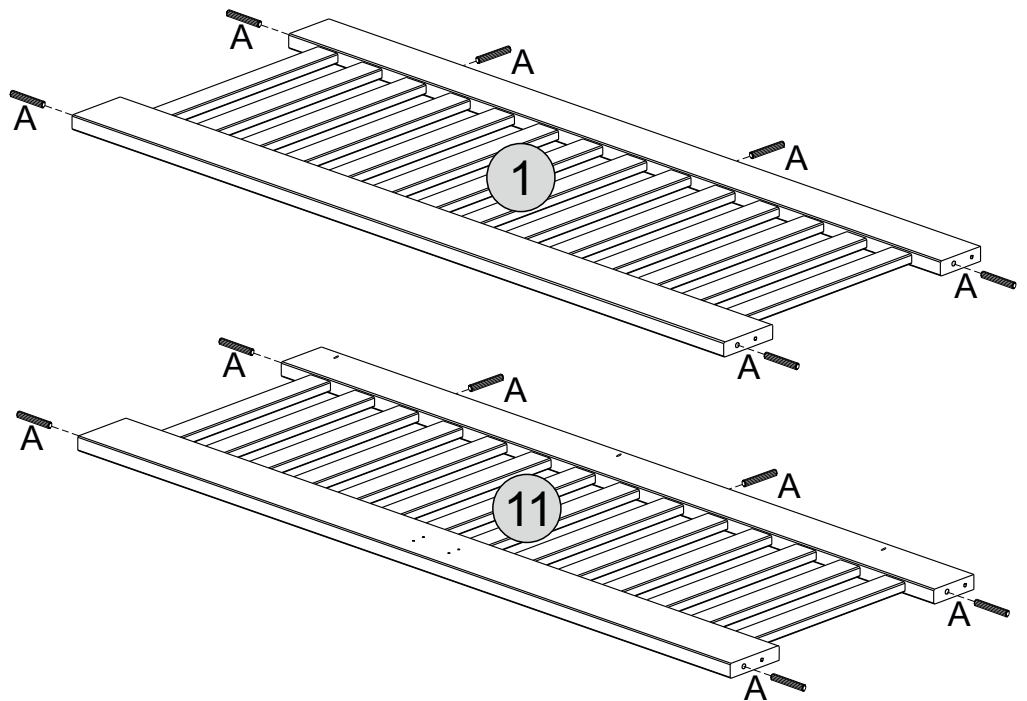

 Please assemble on a clean soft surface to avoid damage.

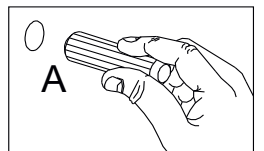

# STEP 3

## PARTS REQUIRED

1 - HEADBOARD PANEL x1

3 - HEADBOARD RIGHT POST (NATURAL) x1

4 - HEADBOARD LEFT POST (GREEN) x1

5 - HEADBOARD CROSSBEAM x1

## HARDWARE REQUIRED

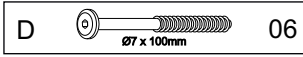

## TOOLS REQUIRED

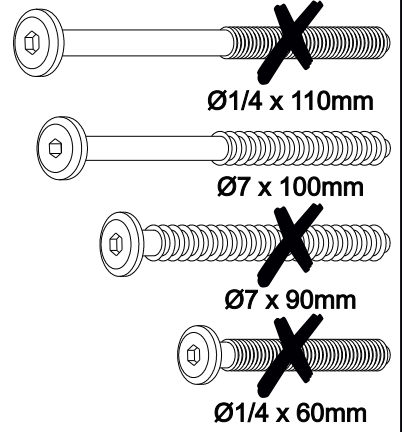
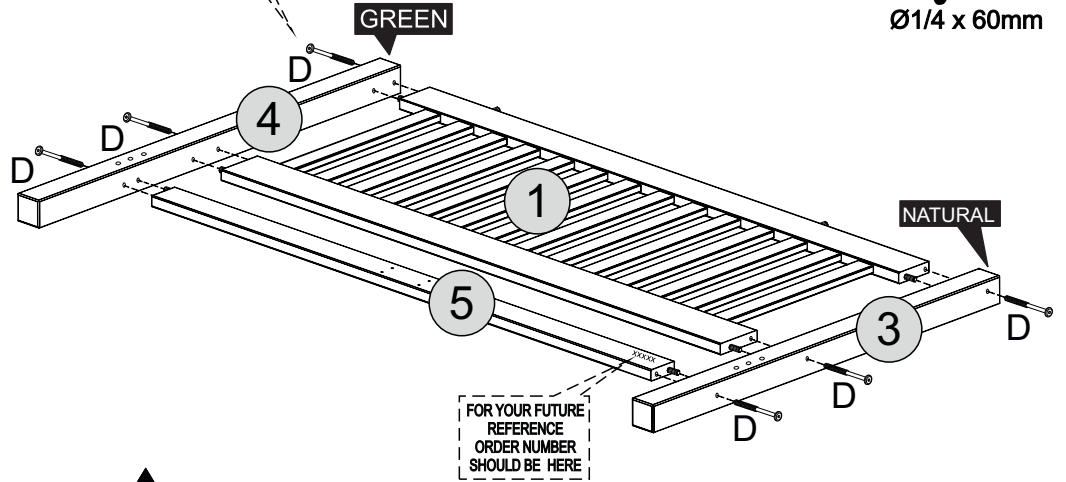
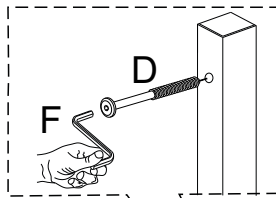
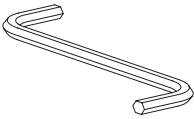

Please assemble on a clean soft surface to avoid damage.

# STEP 4

## PARTS REQUIRED

6 - FOOTBOARD RIGHT POST (NATURAL) x1

7 - FOOTBOARD LEFT POST (GREEN) x1

11- FOOTBOARD PANEL x1

## HARDWARE REQUIRED

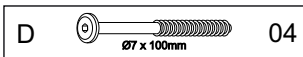

## TOOLS REQUIRED

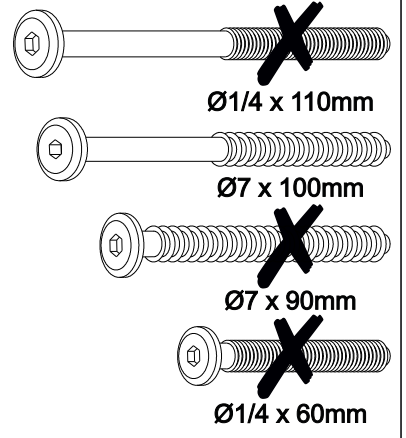
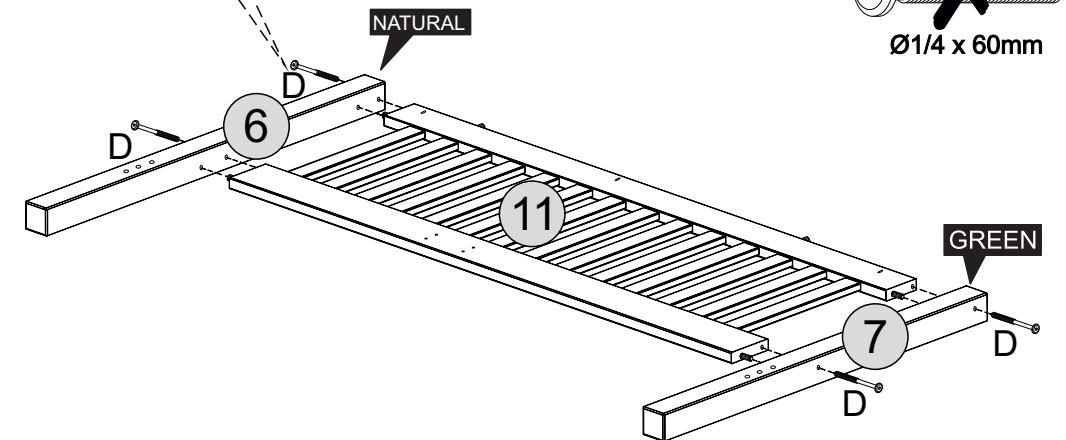
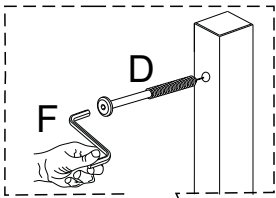
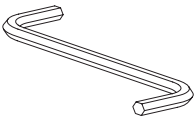

Please assemble on a clean soft surface to avoid damage.

# STEP 5

## PARTS REQUIRED

2 - SIDERAIL x2

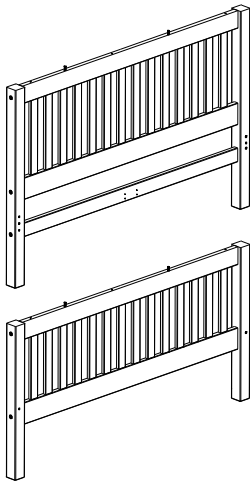

## HARDWARE REQUIRED

B  Ø1/4 x 110mm 04

C  1/4 04

## TOOLS REQUIRED

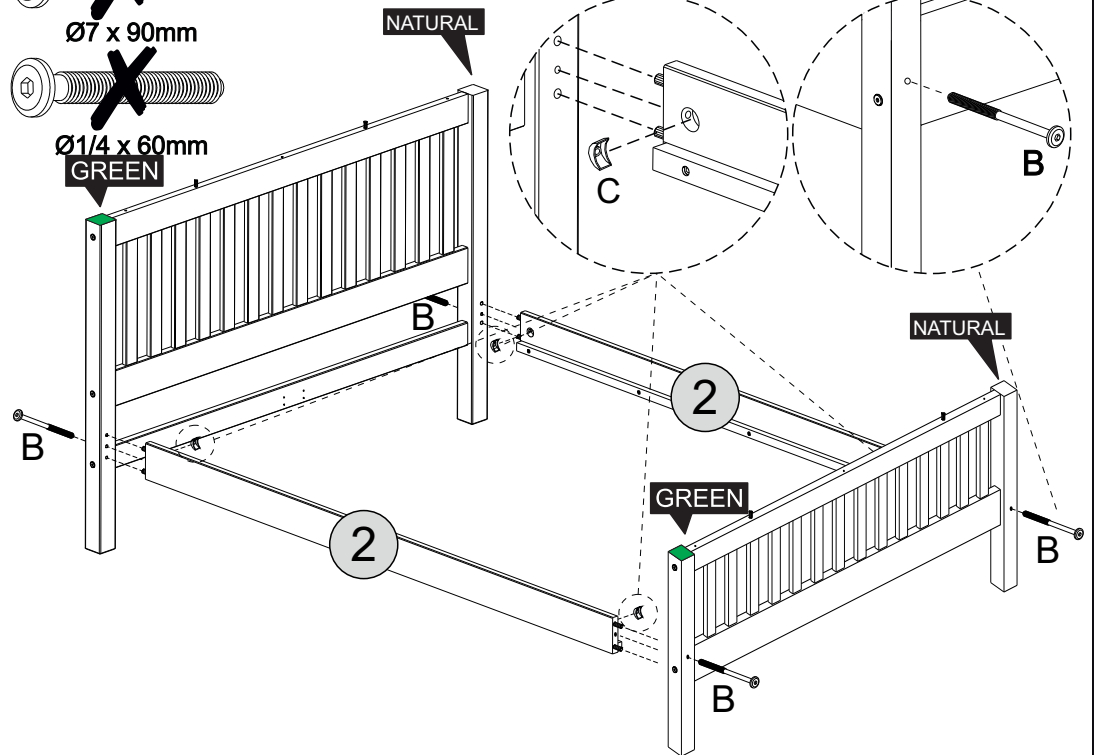
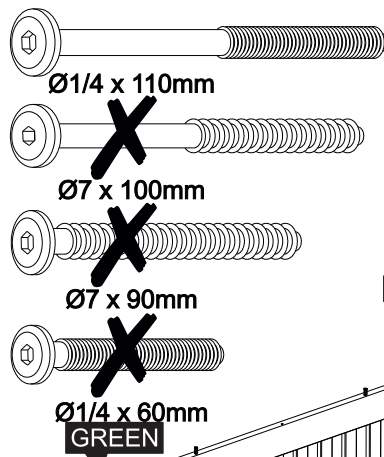
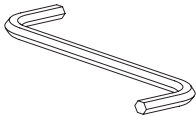

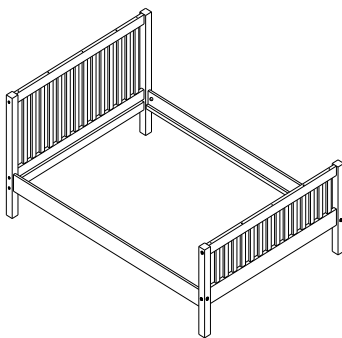

# STEP 6

## PARTS REQUIRED



## HARDWARE REQUIRED

H  Ø4,0 x 16mm 08

I  02

## TOOLS REQUIRED

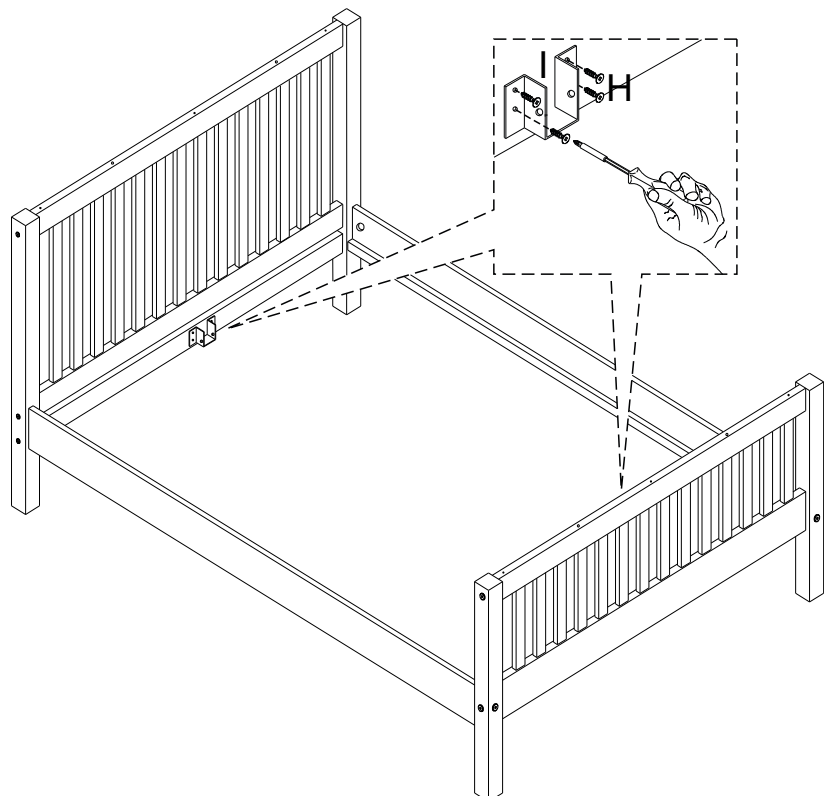
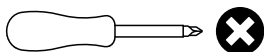

# STEP 7

## PARTS REQUIRED

10 - CENTRE RAIL x1

9- CENTRE SUPPORT LEG x1

## HARDWARE REQUIRED

M  01  
17mm Ø7 x 90mm

## TOOLS REQUIRED

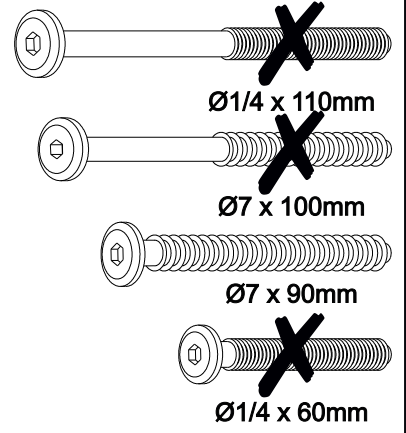
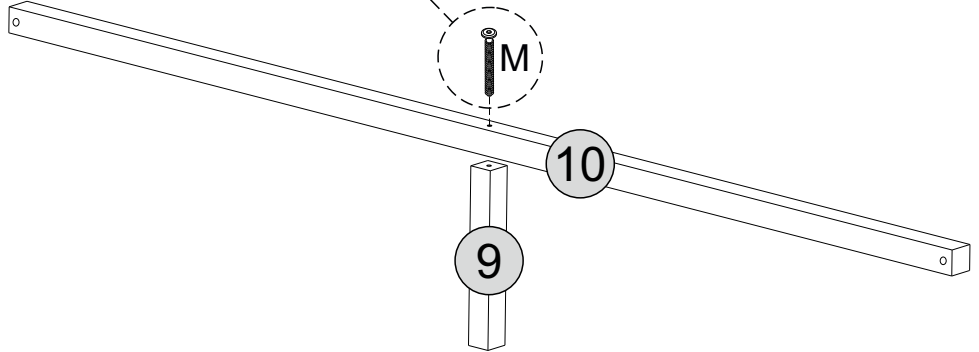
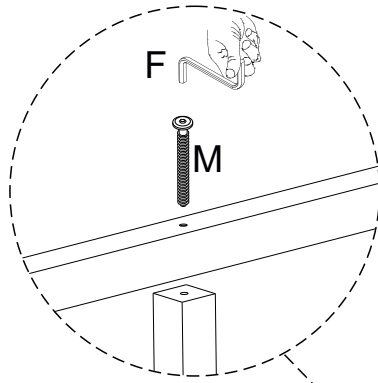
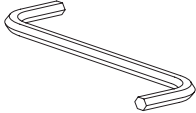

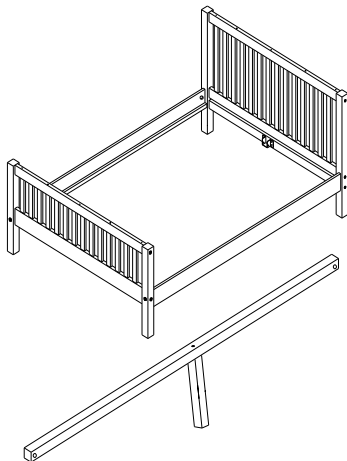

# STEP 8

## PARTS REQUIRED



## HARDWARE REQUIRED

J  02  
17mm Ø1/4 x 60mm

K  1/4 02

## TOOLS REQUIRED

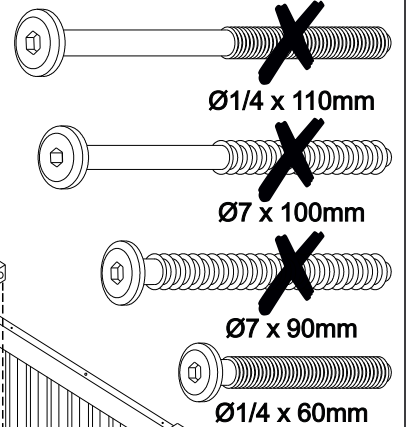
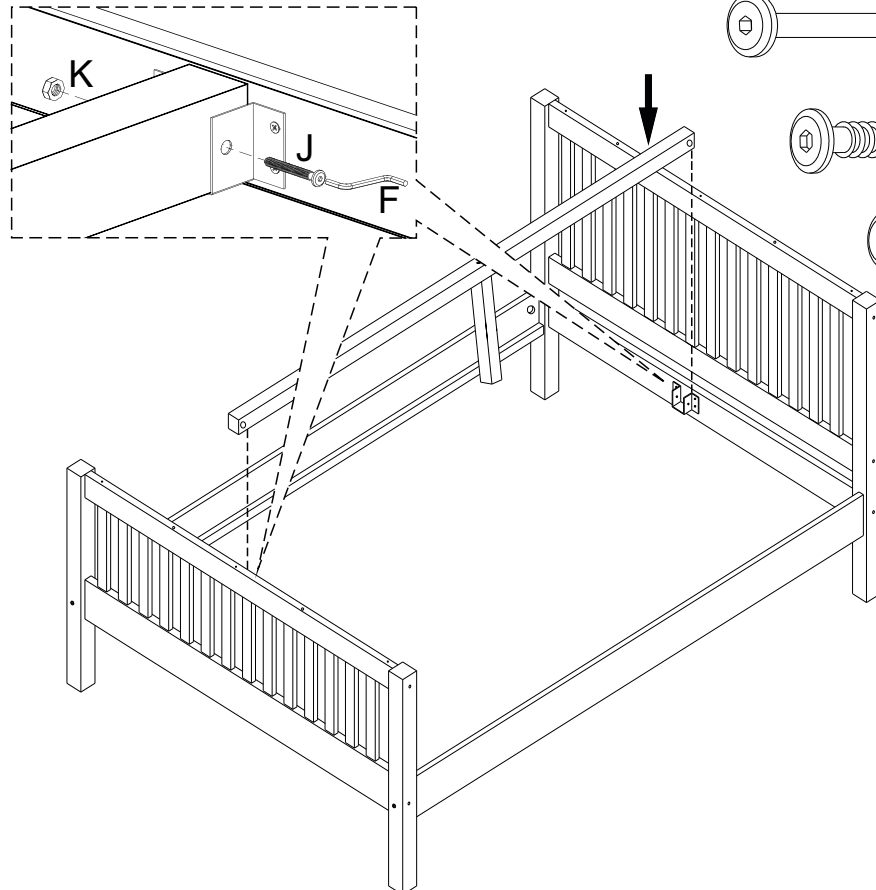
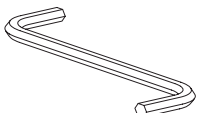

# STEP 9

## PARTS REQUIRED

12- TOP CROSSBEAM x2

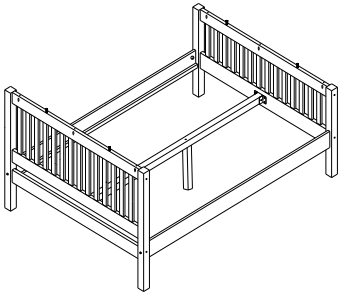

## HARDWARE REQUIRED

L  Ø3,5 x 30mm 06

## TOOLS REQUIRED

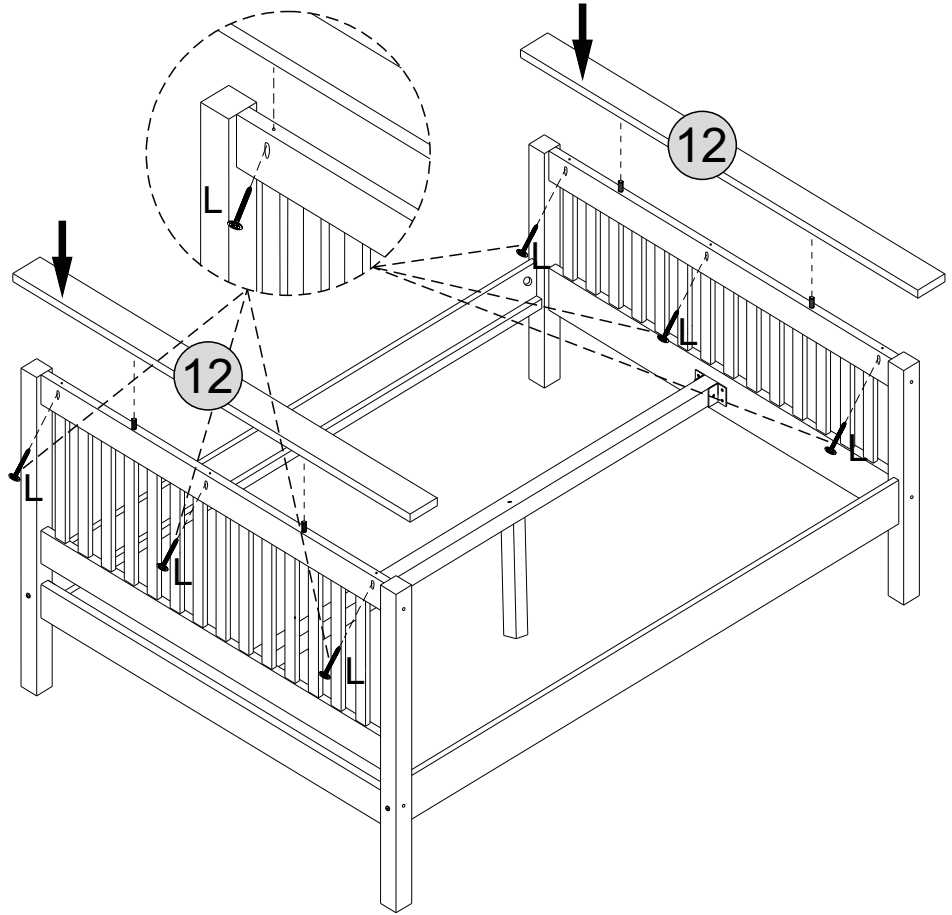
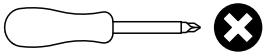

# STEP 10

## PARTS REQUIRED

8 - SLATS (2 HOLES) x28

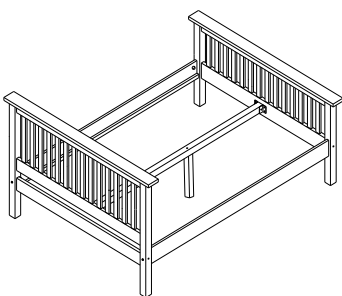

## HARDWARE REQUIRED

E  Ø4,0 x 30mm 56

G  SPACER 87mm 02

## TOOLS REQUIRED

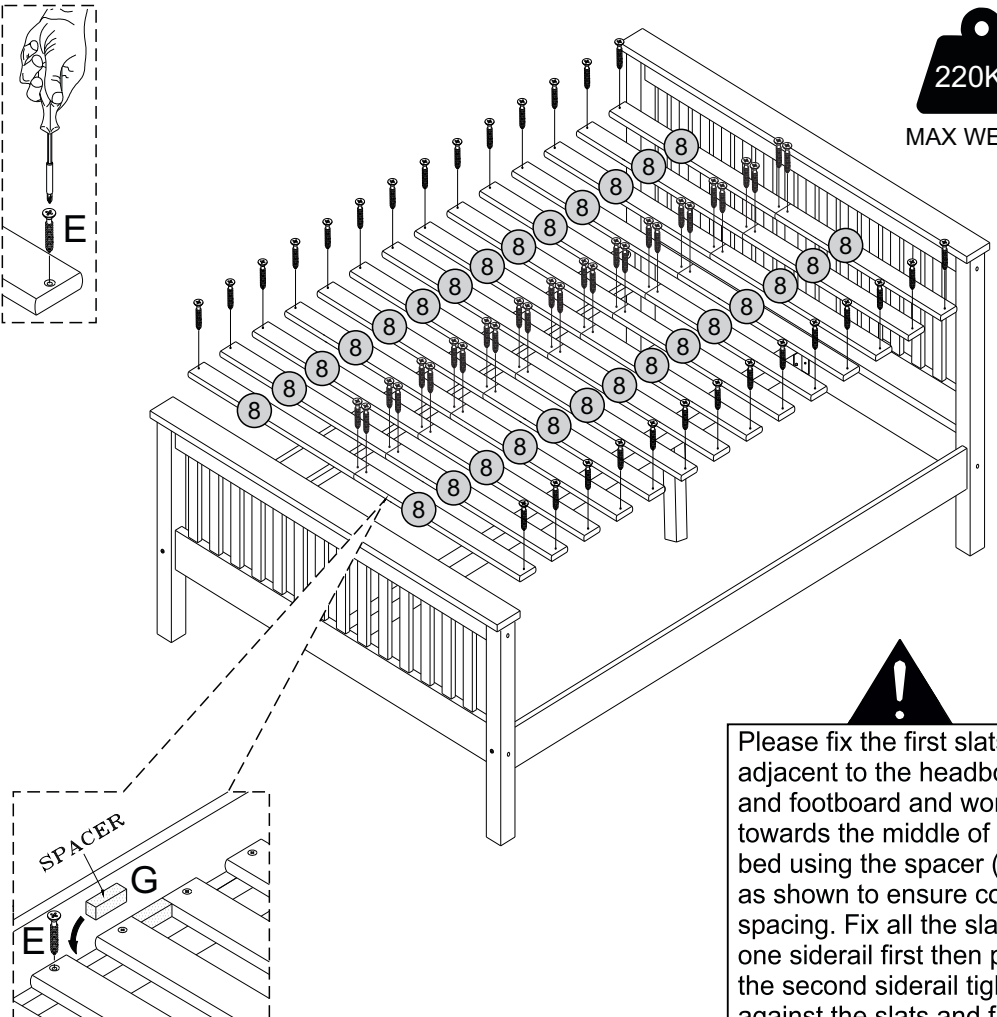
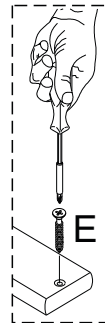
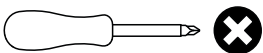

**220KG**  
MAX WEIGHT

**!**  
Please fix the first slats adjacent to the headboard and footboard and work towards the middle of the bed using the spacer ( G ) as shown to ensure correct spacing. Fix all the slats to one siderail first then push the second siderail tight against the slats and fix.