

56196

# OAK EFFECT NEPTUNE 3' BUNK BED ASSEMBLY INSTRUCTIONS

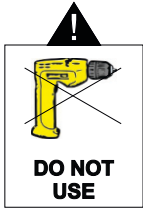

**TOP BUNK  
MAX WEIGHT**



**BOTTOM BUNK  
MAX WEIGHT**

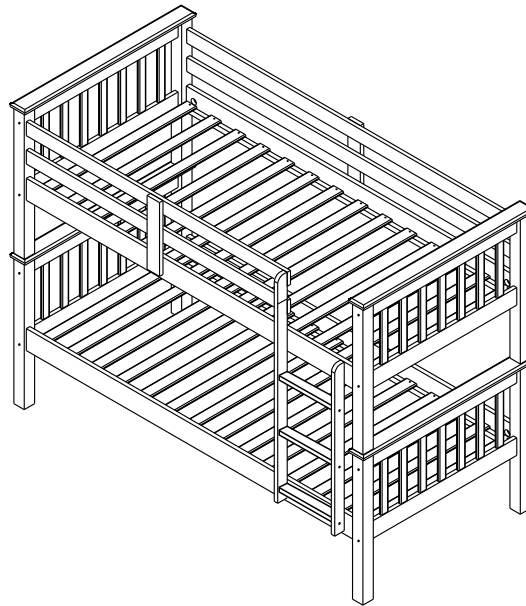

**IMPORTANT  
FOR DOMESTIC USE ONLY**

**PLEASE READ AND FOLLOW THESE INSTRUCTIONS CAREFULLY**

**RETAIN FOR FUTURE REFERENCE  
CARE AND MAINTENANCE**

**WARNING** "High beds and the upper bed of bunk beds are not suitable for children under the age of six years due to the risk of injury from falls".

**WARNING** "Bunk beds and high beds can present a serious risk of injury from strangulation if not used correctly. Never attach or hang items to any part of the bunk bed that are not designed to be used with the bed, for example, but not limited to; ropes, strings, cords, hooks, belts and bags".

**WARNING** "Children can become trapped between the bed and the wall, a roof pitch, the ceiling, adjoining pieces of furniture (e.g. cupboards) and the like. To avoid risk of serious injury the distance between the top safety barrier and the adjoining structure shall not exceed 75mm or shall be more than 230mm".

**WARNING** Do not use the bunk bed/high bed if any structural part is broken or missing.

The recommended mattress size for this bunk bed is 1900mm x 915mm x 150mm.

The maximum mattress height is 160mm.

The maximum mattress height is clearly marked on the bunk bed and **MUST NOT BE EXCEEDED**.

Depending on the amount of use this product receives it may be necessary to tighten up the fixings from time to time, this is completely normal for all flat pack furniture. **DO NOT OVER TIGHTEN FIXINGS**. Do not for any reason use a power tool to assemble this product.

Two persons are required to assemble this bunk bed.

Assemble as close to its final position as possible.

Assemble on a soft clean surface.

For cleaning you may use a damp cloth (not wet).

The room in which the bed is positioned should be ventilated to prevent mould in and around the bed.

This bunk bed is manufactured to conform to BS EN 747:2012+A1:2015

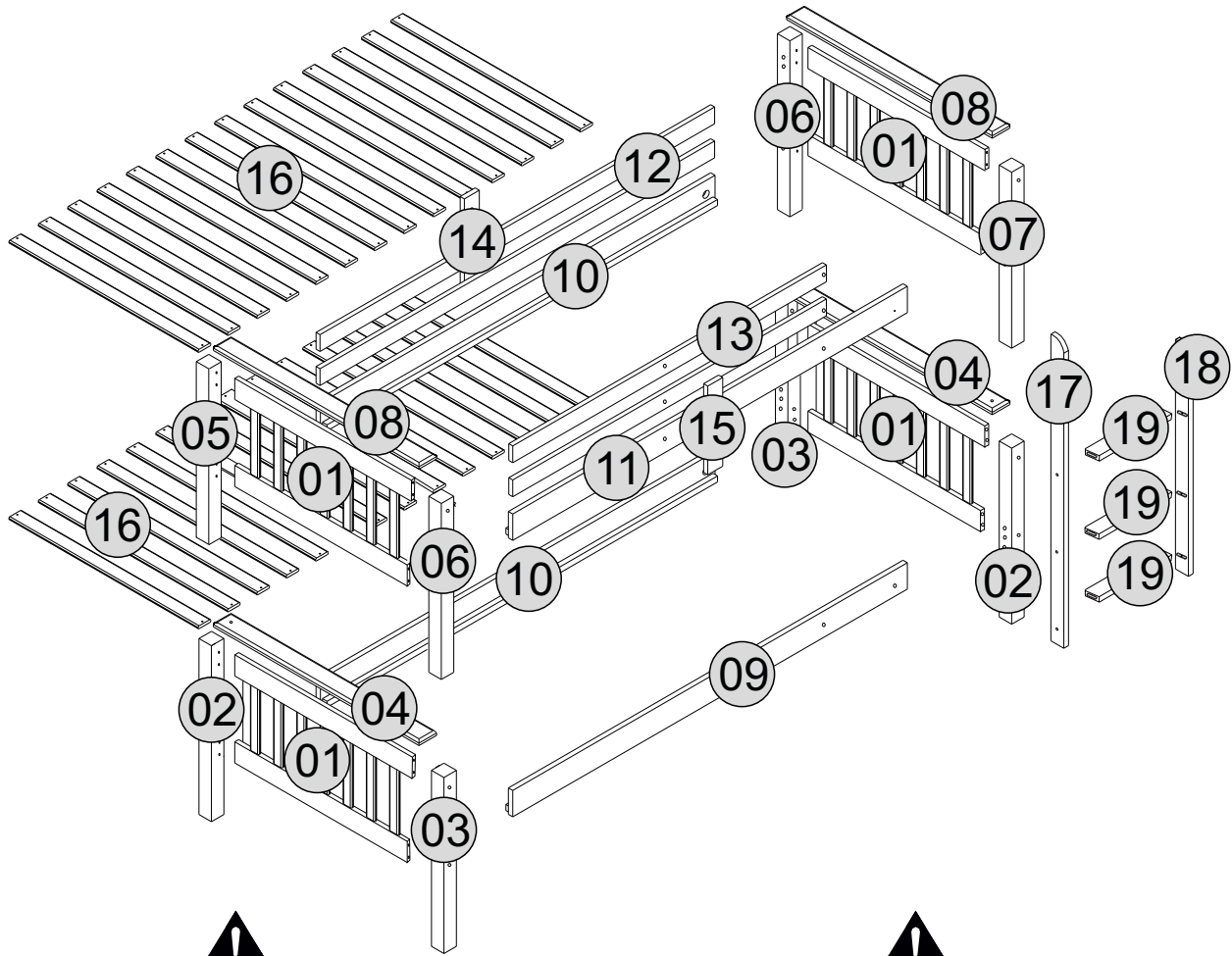







\* Use of power tools to assemble this product will invalidate any claim and damage this product making it unsafe !!!  
\* Please assemble on a clean soft surface to avoid damage.

\* Please check contents and read the instructions before commencing assembly.  
\* Assemble this product following the enclosed instructions carefully.  
\* Please take care to avoid damaging panels during assembly.

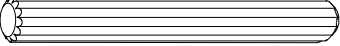
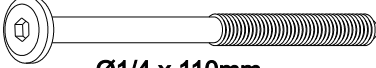
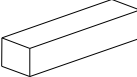
## PARTS LIST

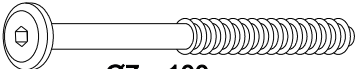
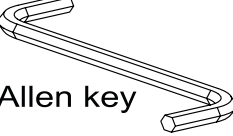
Part Number	Part Code	Part Description	Quantity	Carton
01	S200-205-008-PJ1-01	Headboard Panel	4	1/3
02	S200-205-008-PJ1-02	Left Post (Bottom Bunk) (Yellow)	2	1/3
03	S200-205-008-PJ1-03	Right Post (Bottom Bunk) (Blue)	2	1/3
04	S200-205-008-PJ1-04	Bottom Headboard Plinth	2	2/3
05	S200-205-008-PJ1-05	Upper Left Post/Guard-Rail (Grey)	1	1/3
06	S200-205-008-PJ1-06	Upper Right Post/Guard-Rail (Red)	2	1/3
07	S200-205-008-PJ1-07	Upper Left Post (Ladder Side) (Natural)	1	1/3
08	S200-205-008-PJ1-08	Top Headboard Plinth	2	2/3
09	S200-205-008-PJ1-09	Side Rail With Holes For Ladder	1	2/3
10	S200-205-008-PJ1-10	Side Rail	2	2/3
11	S200-205-008-PJ1-11	Side Rail With Holes For Support Brace	1	2/3
12	S200-205-008-PJ1-12	Long Safety Rail	2	2/3
13	S200-205-008-PJ1-13	Short Safety Rail	2	2/3
14	S200-205-008-PJ1-14	Support Brace With Hole	1	2/3
15	S200-205-008-PJ1-15	Support Brace	1	2/3
16	S200-205-008-PJ1-16	Slats	28	3/3
17	S200-205-008-PJ1-17	Long Ladder Upright	1	2/3
18	S200-205-008-PJ1-18	Short Ladder Upright	1	2/3
19	S200-205-008-PJ1-19	Ladder Step	3	2/3

### FITTINGS

A	 Ø8 x 50mm	54	G	 Ø10 x 100mm	04
B	 Ø1/4 x 110mm	08	H	 SPACER (WOODEN)	02
C	 1/4	08	I	 3,5 x 35mm	56
D	 Ø7 x 100mm	22	J	 Allen key	01
E	 Ø4,0 x 35mm	14			
F	 Ø7 x 50mm	06	K	 GLUE	03
			L	 Ø4,0 x 25mm	06

### TOOLS REQUIRED

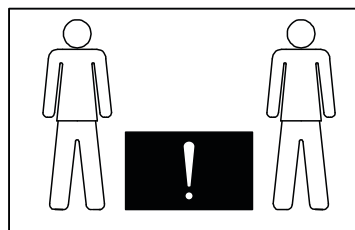
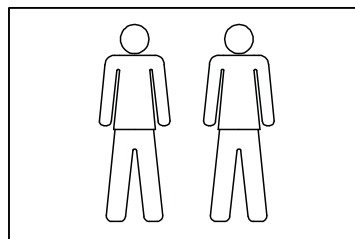
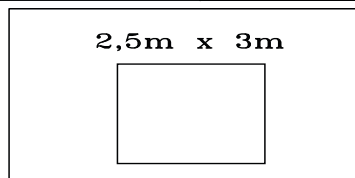
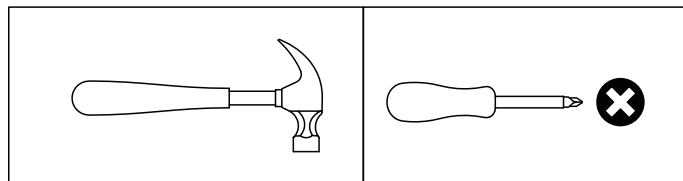

# STEP 1

## PARTS REQUIRED

01- HEADBOARD PANEL x4

## HARDWARE REQUIRED

A  28  
Ø8 x 50mm

K  01  
GLUE

## TOOLS REQUIRED

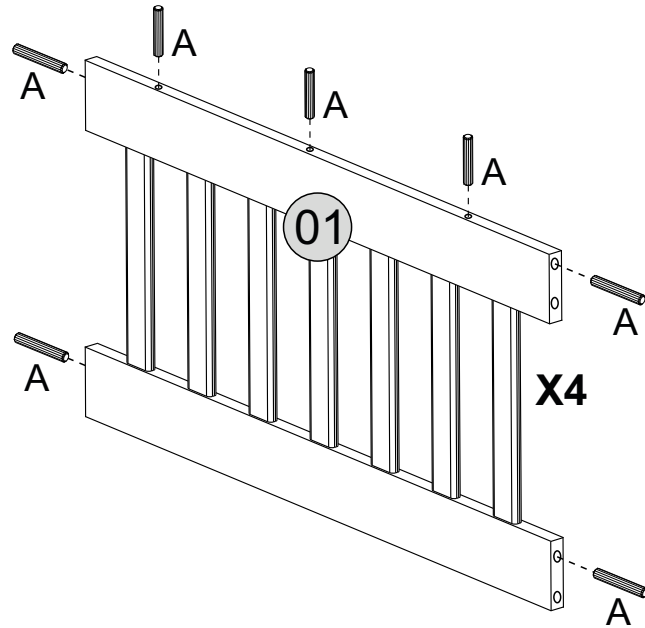

**!**  
Please assemble on a clean soft surface to avoid damage.

**!**  
Glue must be added to the dowel holes on part 01.

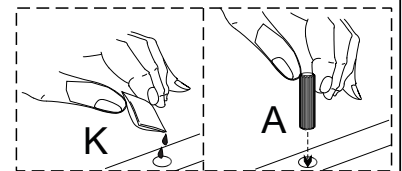

# STEP 2

## PARTS REQUIRED

01- HEADBOARD PANEL x2

02- LEFT POST (BOTTOM) (YELLOW) x2

03- RIGHT POST (BOTTOM) (BLUE) x2

## HARDWARE REQUIRED

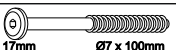
D  08  
17mm Ø7 x 100mm

K  01  
GLUE

## TOOLS REQUIRED

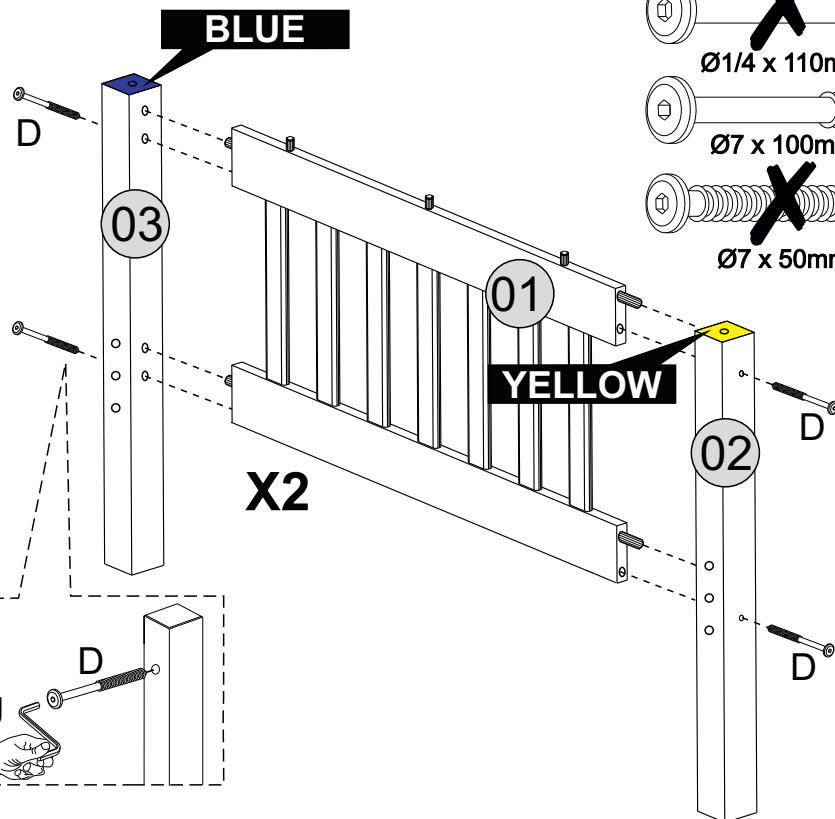
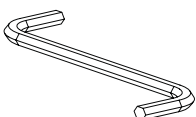

**!**  
Please assemble on a clean soft surface to avoid damage.

**!**  
Glue must be added to the dowel holes on part 01,02 and 03.

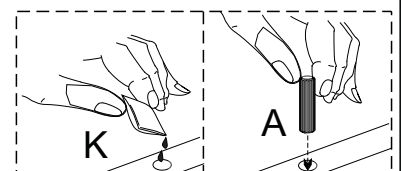



# STEP 3

## PARTS REQUIRED

01- HEADBOARD PANEL	x1
05- UPPER LEFT/GUARD RAIL (GREY)	x1
06- UPPER RIGHT/GUARD RAIL (RED)	x1

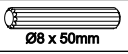
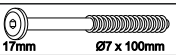
## HARDWARE REQUIRED

A		02
D		04
K		01

## TOOLS REQUIRED

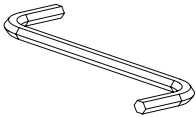

**RED**

**GREY**

**!** Please assemble on a clean soft surface to avoid damage.

**!** Glue must be added to the dowel holes on part 05 and 06.

**X** Ø1/4 x 110mm

**X** Ø7 x 50mm



01, 05, 06, A, D, J, K

# STEP 4

## PARTS REQUIRED

01- HEADBOARD PANEL	x1
06- UPPER RIGHT/GUARD RAIL (RED)	x1
07- UPPER LEFT POST (LADDER SIDE)	x1

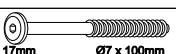
## HARDWARE REQUIRED

A		02
D		04
K		01

## TOOLS REQUIRED

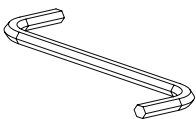

**RED**

**NATURAL**

**!** Please assemble on a clean soft surface to avoid damage.

**!** Glue must be added to the dowel holes on part 06 and 07.

**X** Ø1/4 x 110mm

**X** Ø7 x 50mm

01, 06, 07, A, D, J, K

FOR YOUR FUTURE REFERENCE ORDER NUMBER SHOULD BE HERE

# STEP 5

## PARTS REQUIRED

09- SIDE RAIL (LADDER HOLES) x1

10- SIDE RAIL x2

11-SIDE RAIL (SUPPORT BRACE HOLES) x1

## HARDWARE REQUIRED

A  16  
Ø8 x 50mm

## TOOLS REQUIRED

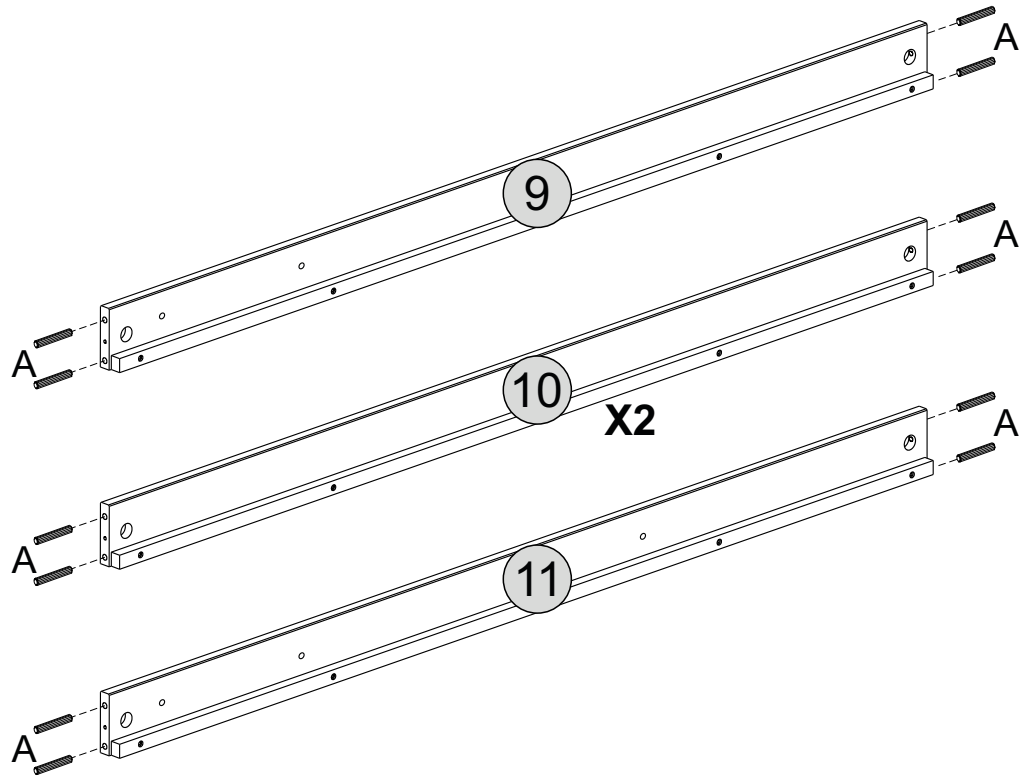

# STEP 6

## PARTS REQUIRED

12- LONG SAFETY RAIL x2

13- SHORT SAFETY RAIL x2

## HARDWARE REQUIRED

A  06  
Ø8 x 50mm

## TOOLS REQUIRED

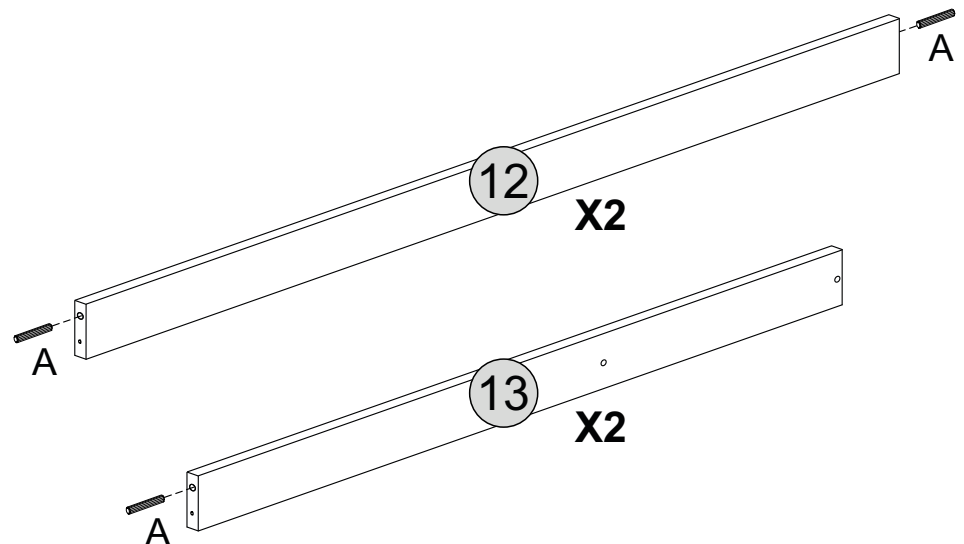

# STEP 7

## PARTS REQUIRED

09- SIDE RAIL (LADDER HOLES) x1

10- SIDE RAIL x1

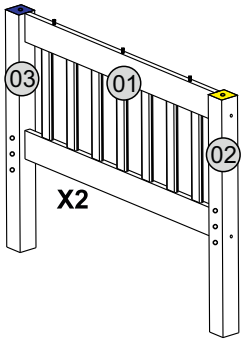

## HARDWARE REQUIRED

B  17mm  $\varnothing 1/4 \times 110\text{mm}$  04

C  1/4 04

## TOOLS REQUIRED

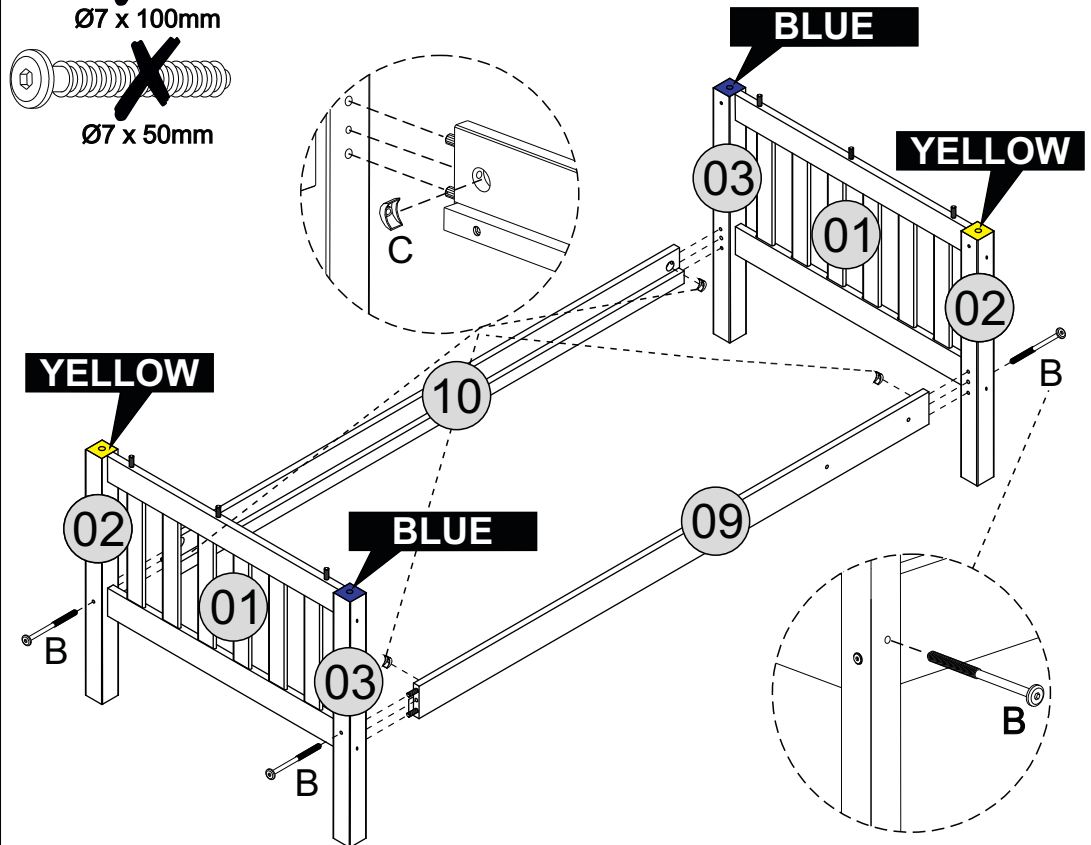
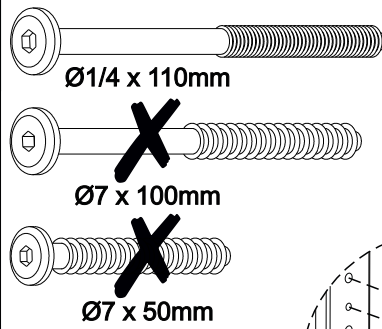
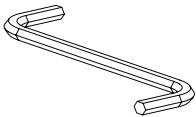

# STEP 8

## PARTS REQUIRED

04-BOTTOM HEADBOARD PLINTH x2

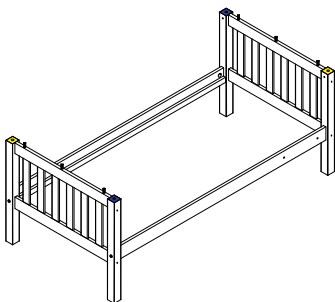

## HARDWARE REQUIRED

K  GLUE 01

## TOOLS REQUIRED

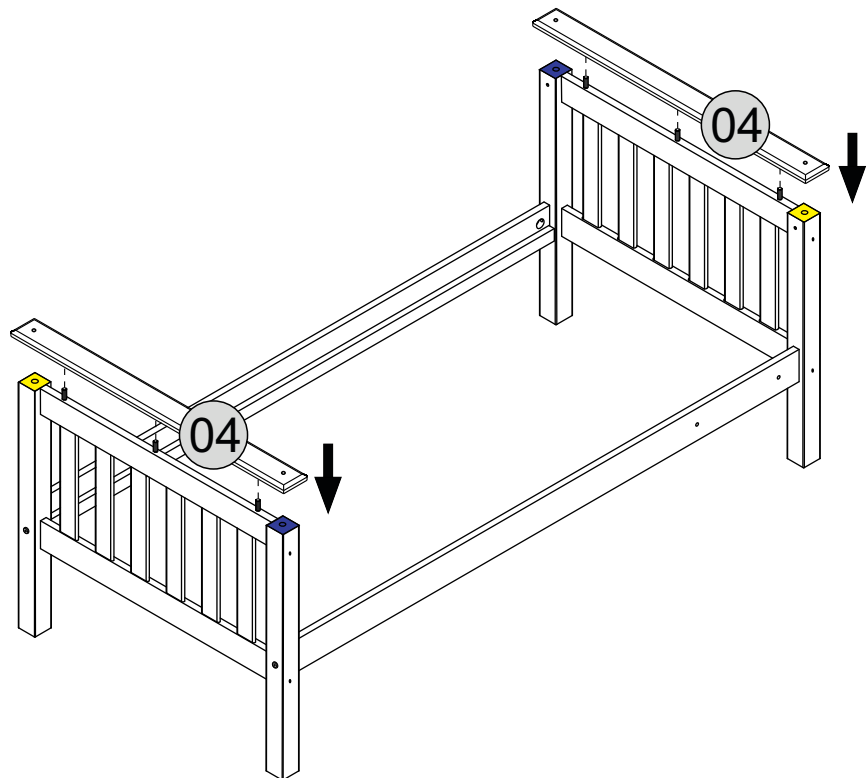

 **Glue must be added to the dowel holes on part 04.**

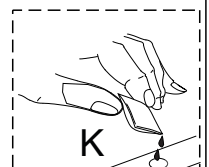





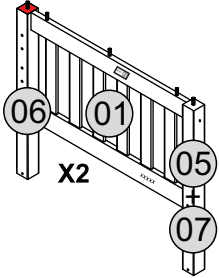

# STEP 9

## PARTS REQUIRED

- 10- SIDE RAIL x1
- 11-SIDE RAIL (SUPPORT BRACE HOLES) x1
- 12- LONG SAFETY RAIL x2



## HARDWARE REQUIRED

- B  17mm  $\varnothing 1/4 \times 110\text{mm}$  04
- C  1/4 04
- D  17mm  $\varnothing 7 \times 100\text{mm}$  04

## TOOLS REQUIRED

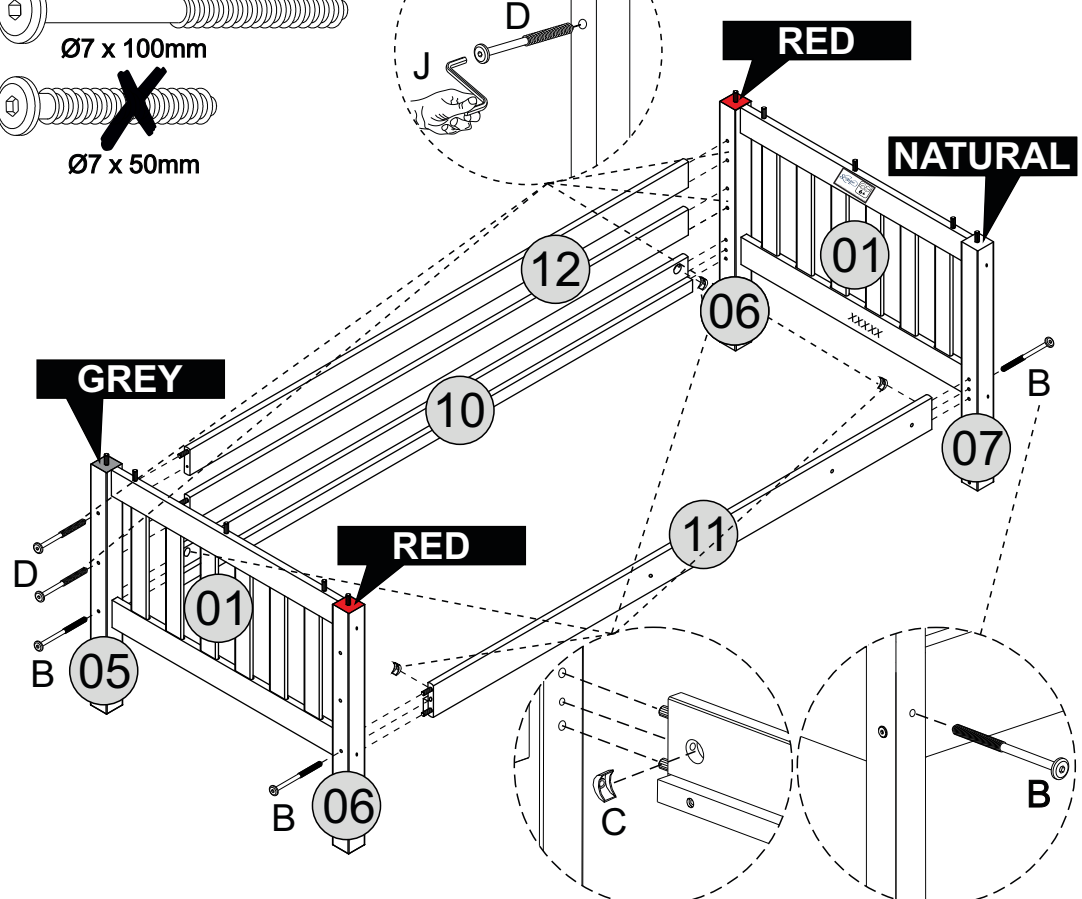
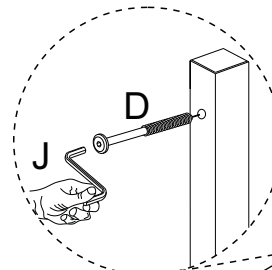
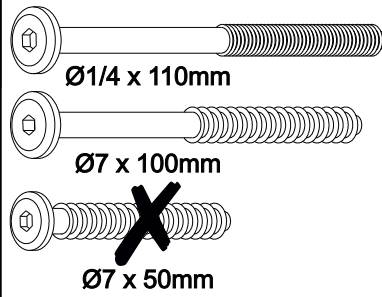
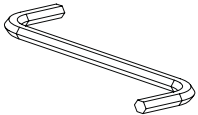

# STEP 10

## PARTS REQUIRED

- 08 -TOP HEADBOARD PLINTH x2

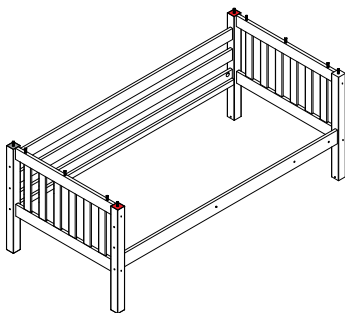

## HARDWARE REQUIRED

- K  GLUE 01

## TOOLS REQUIRED

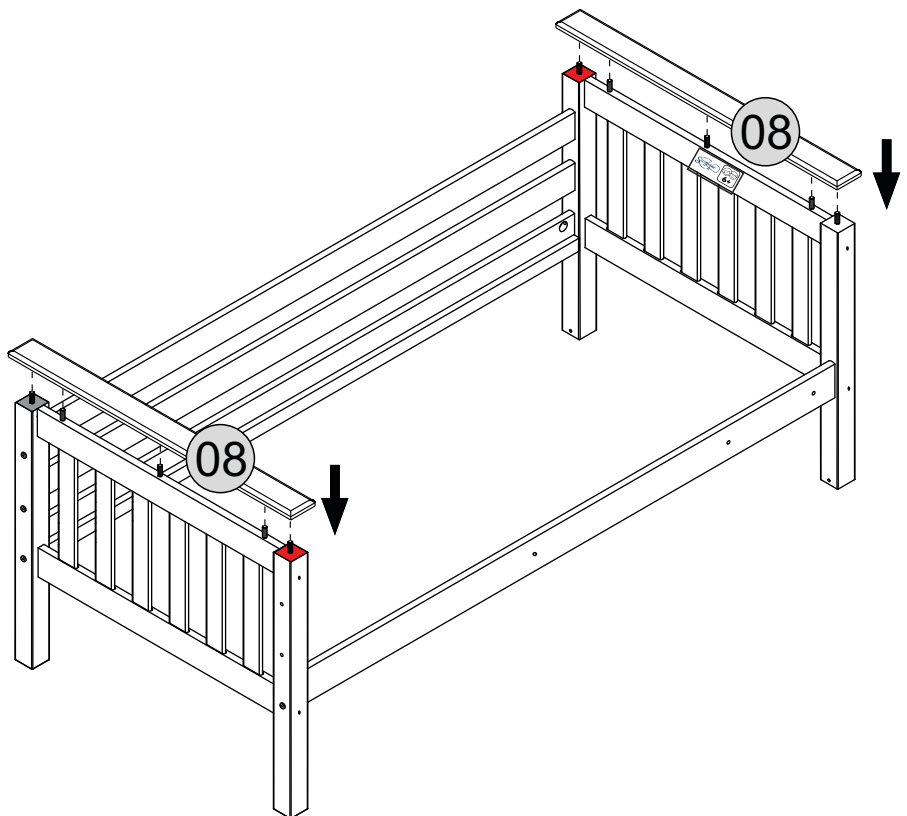

**!**  
Glue must be added to the dowel holes on part 08.

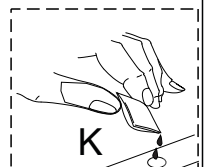



# STEP 11

## PARTS REQUIRED

16 - SLATS x14

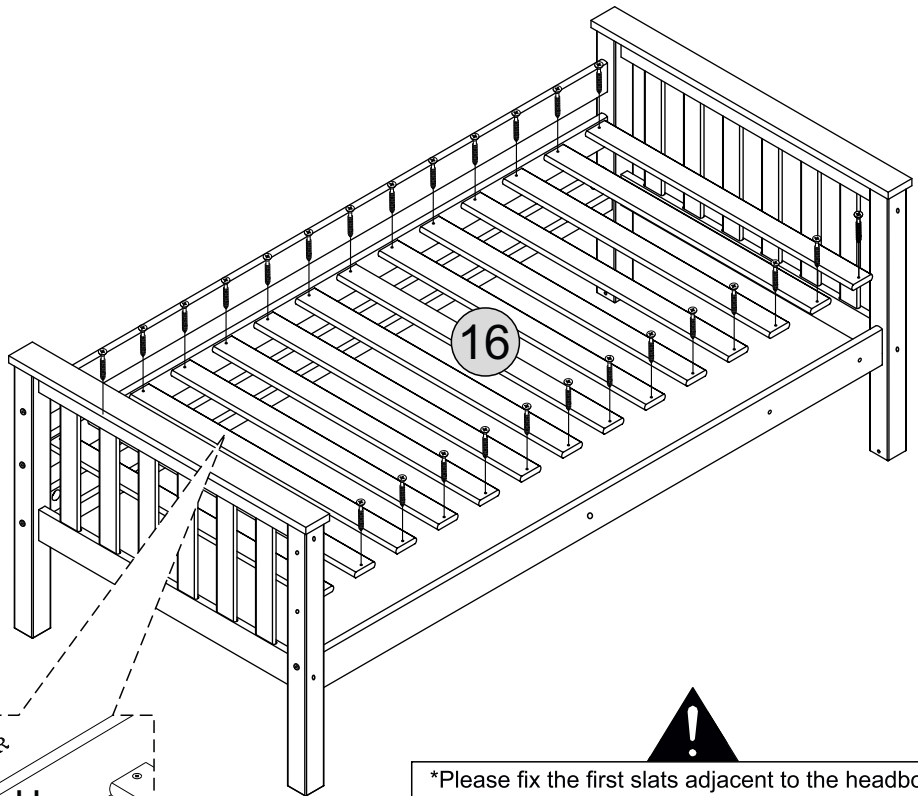
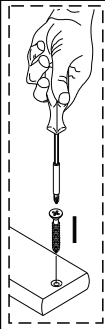
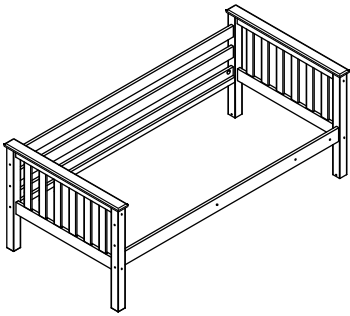

## HARDWARE REQUIRED

H  SPACER (WOODEN) 02

I  3,5 x 35mm 28

## TOOLS REQUIRED

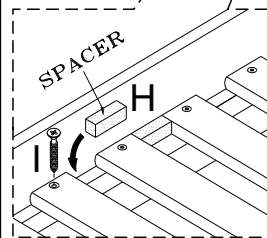
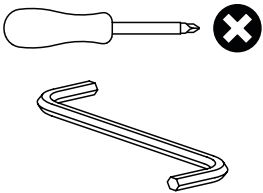

**!**  
\*Please fix the first slats adjacent to the headboard and footboard and work towards the middle of the bed using the spacer (H) as shown to ensure correct spacing. Fix all the slats to one siderail first then push the opposite siderail tight against the slats and fix. Please retain the Allen Key (J) and use periodically to check that all bolts are tight.

# STEP 12

## PARTS REQUIRED

16 - SLATS x14

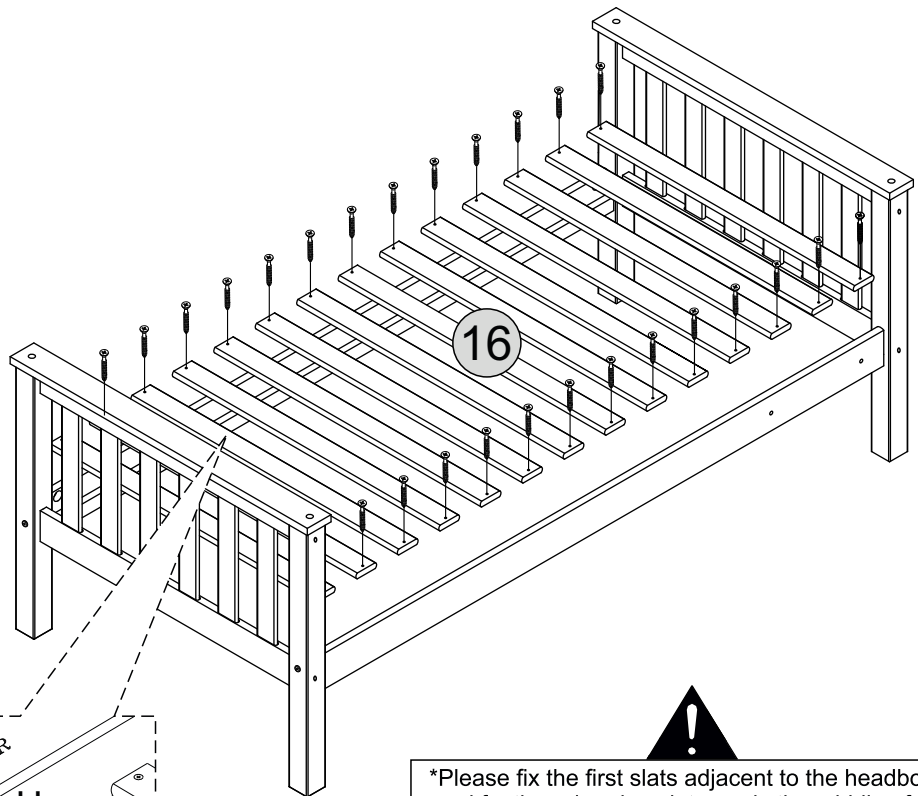
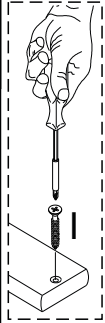
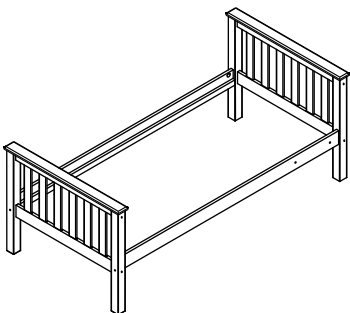

## HARDWARE REQUIRED

H  SPACER (WOODEN) 02

I  3,5 x 35mm 28

## TOOLS REQUIRED

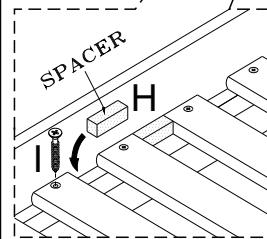
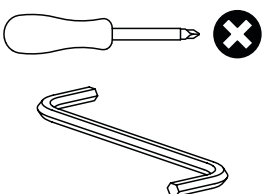

**!**  
\*Please fix the first slats adjacent to the headboard and footboard and work towards the middle of the bed using the spacer (H) as shown to ensure correct spacing. Fix all the slats to one siderail first then push the opposite siderail tight against the slats and fix. Please retain the Allen Key (J) and use periodically to check that all bolts are tight.

# STEP 13

## PARTS REQUIRED

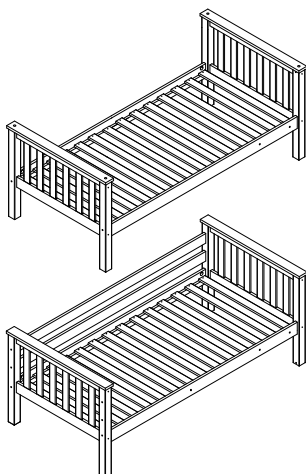

## HARDWARE REQUIRED

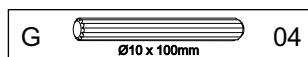
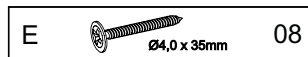

## TOOLS REQUIRED

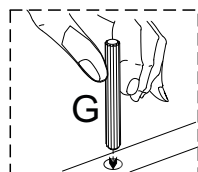
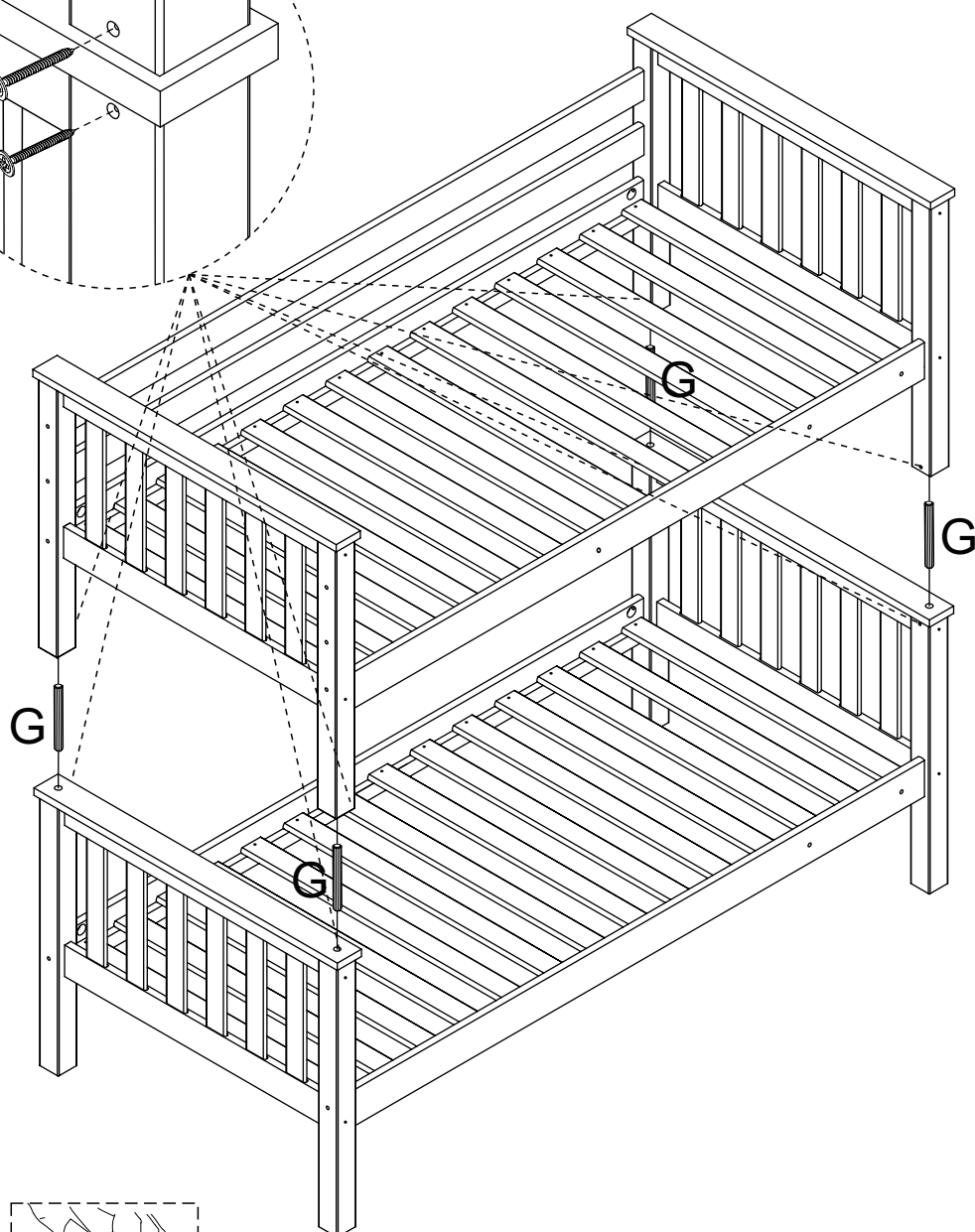
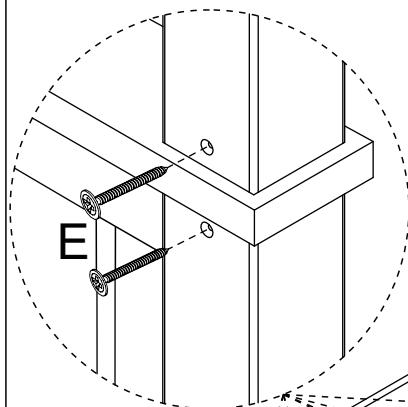
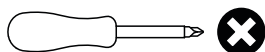



# STEP 14

## PARTS REQUIRED

17- LONG LADDER UPRIGHT	x1
18- SHORT LADDER UPRIGHT	x1
19- LADDER STEP	x3

## HARDWARE REQUIRED

K		GLUE	01
L		Ø4,0 x 25mm	06

## TOOLS REQUIRED

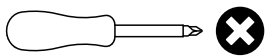

ADD GLUE AS BELOW

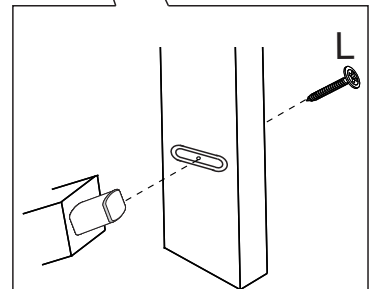
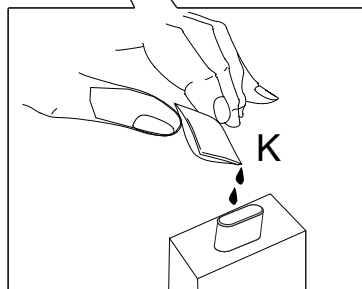
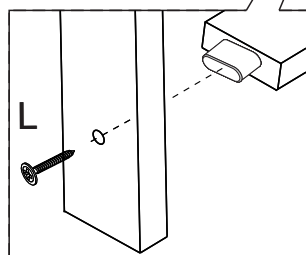
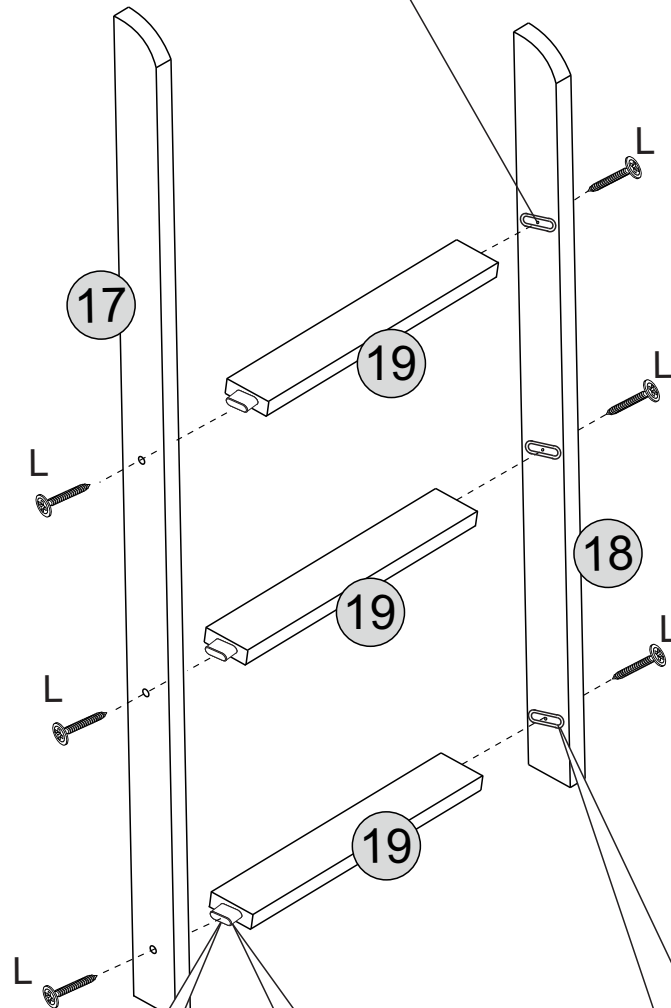
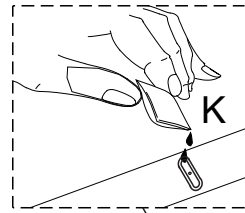

ADD GLUE AS ABOVE!

# STEP 15

## PARTS REQUIRED

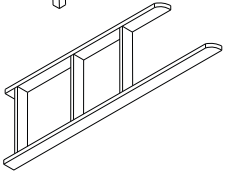
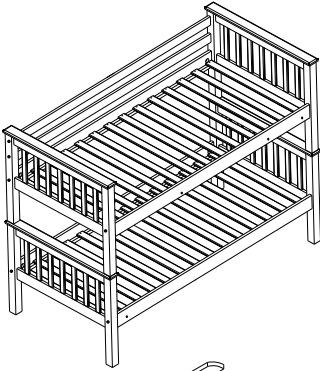

## HARDWARE REQUIRED

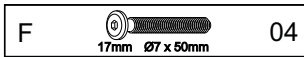

## TOOLS REQUIRED

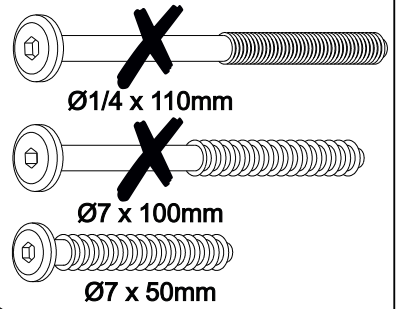
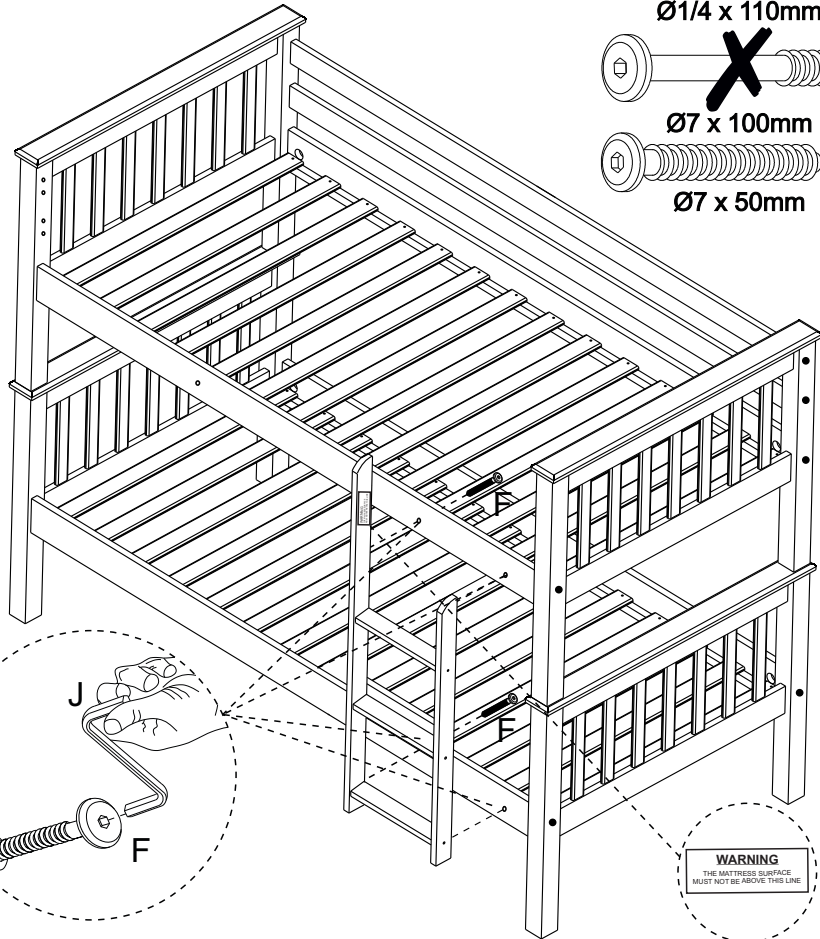
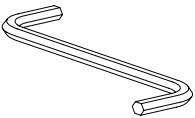

# STEP 16

## PARTS REQUIRED

13- SHORT SAFETY RAIL x2

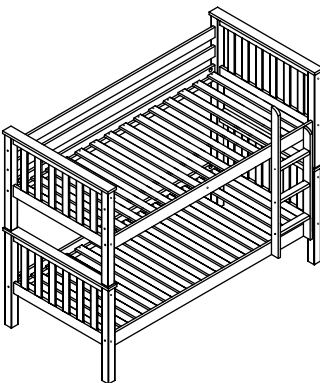

## HARDWARE REQUIRED

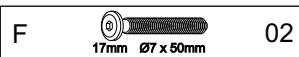
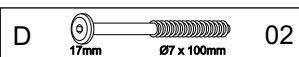

## TOOLS REQUIRED

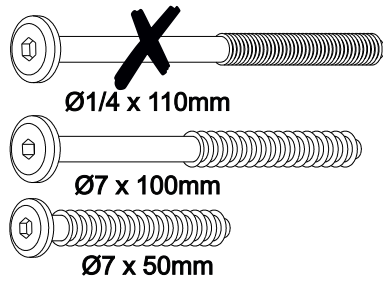
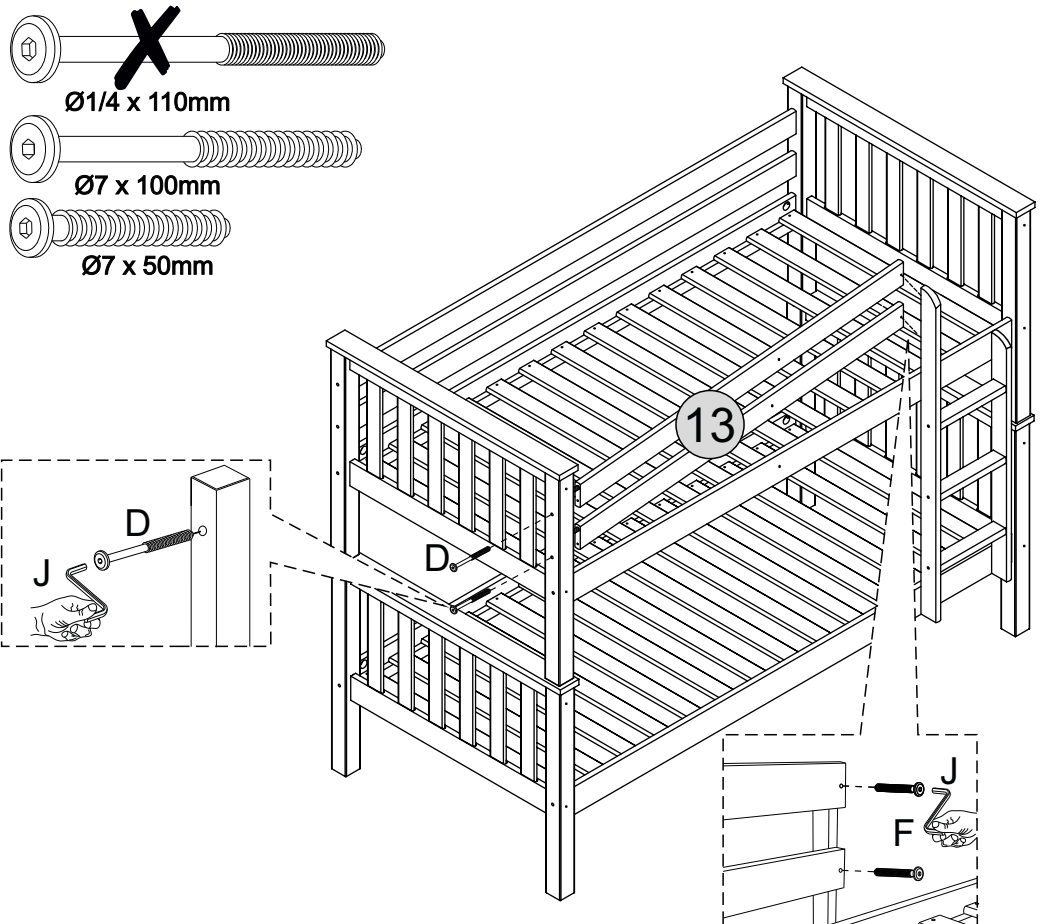
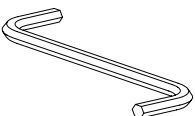

# STEP 17

**PARTS REQUIRED**

14- SUPPORT BRACE WITH HOLE x1

15- SUPPORT BRACE x1

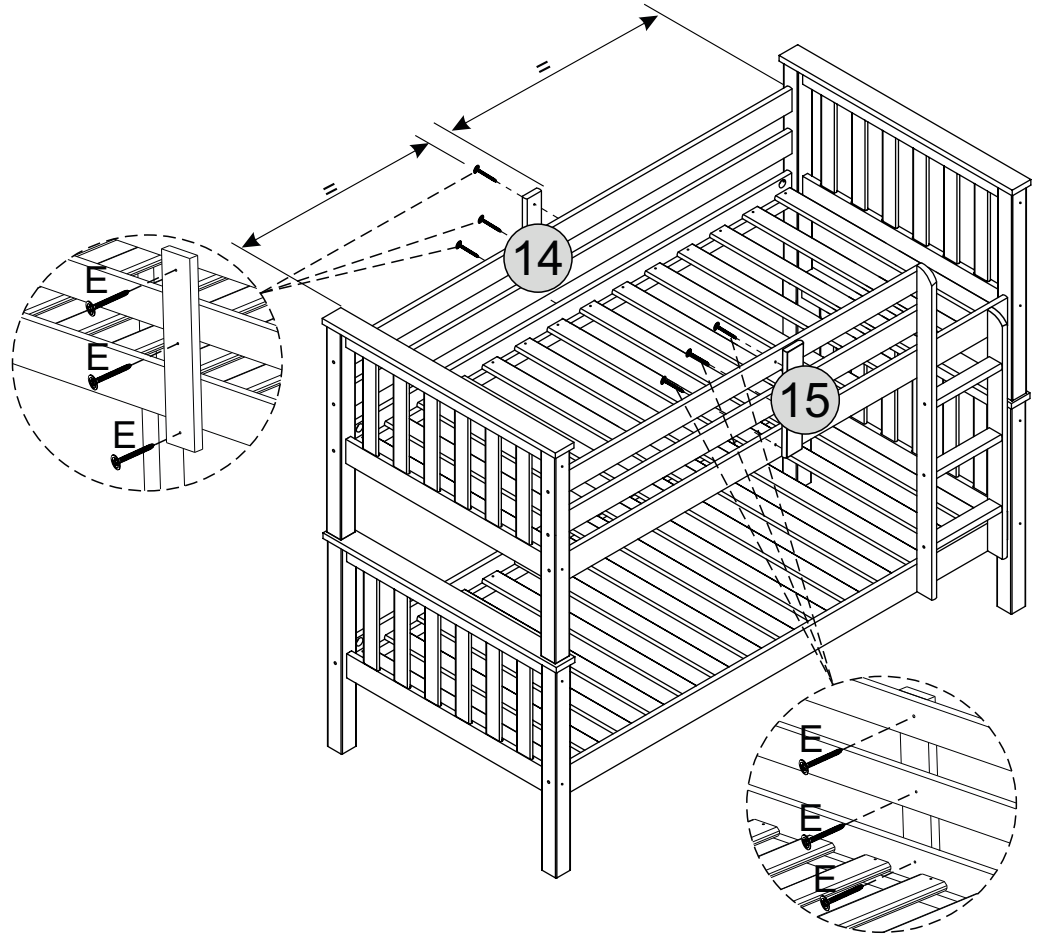
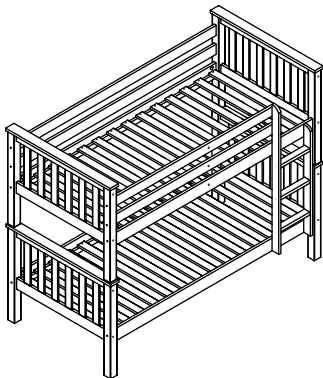

**HARDWARE REQUIRED**

E  06  
Ø4,0 x 35mm

**TOOLS REQUIRED**

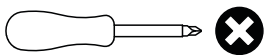

# STEP 18

**PARTS REQUIRED**

**HARDWARE REQUIRED**

**TOOLS REQUIRED**

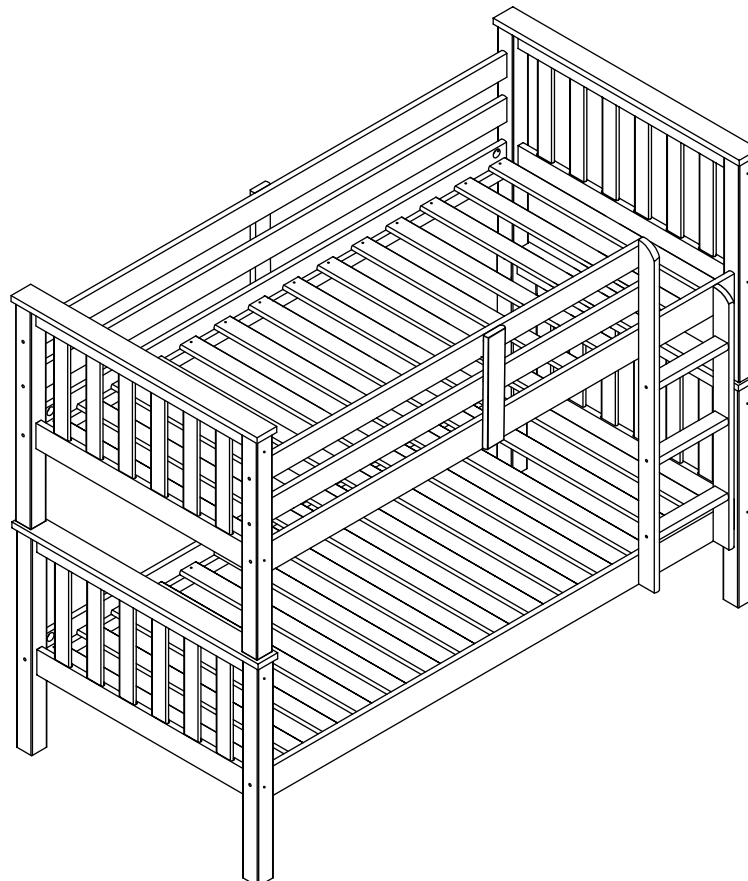

TOP BUNK  
MAX WEIGHT



BOTTOM BUNK  
MAX WEIGHT