

ELENA COFFEE TABLE ASSEMBLY INSTRUCTIONS

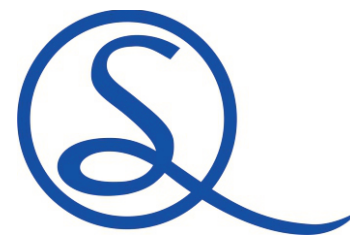
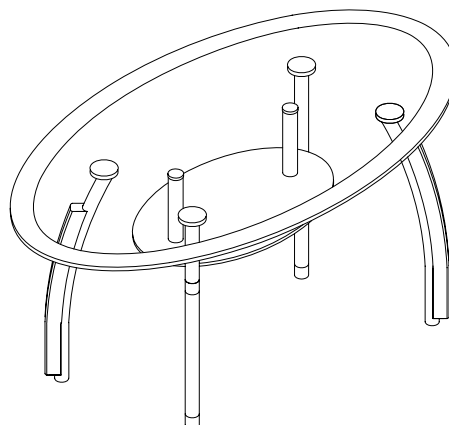

IMPORTANT FOR DOMESTIC USE ONLY PLEASE READ BEFORE YOU CONTINUE FURTHER

THE PRODUCT YOU HAVE PURCHASED WILL GIVE YOU MANY YEARS OF OF SERVICE. IF YOU FOLLOW THE GUIDELINES FOR ITS SAFE ASSEMBLY AND PERIODIC MAINTENANCE AND CLEANING.

ASSEMBLE ON A SOFT CLEAN SURFACE.

DO NOT USE ANY TOOLS OTHER THAN THOSE SHOWN.

ANY SPANNERS OR ALLEN KEYS REQUIRED ARE INCLUDED WITH THE FITTINGS KIT.

DO NOT FOR ANY REASON USE A POWER TOOL TO ASSEMBLE THIS PRODUCT. ITS USE WILL INVALIDATE ANY CLAIM YOU MAY HAVE AND COULD MAKE THIS PRODUCT UNSAFE.

DEPENDING ON THE AMOUNT OF USE THIS PRODUCT RECIEVES IT MAY BE NECESSARY TO TIGHTEN UP THE FIXINGS FROM TIME TO TIME. THIS IS COMPLETELY NORMAL FOR ANY FLAT PACK FURNITURE.
DO NOT OVERTIGHTEN FIXINGS.

DO NOT DRAG FURNITURE AS THIS CAN CAUSE DAMAGE TO THE JOINTS.

DO NOT USE FURNITURE POLISH AS THIS WILL SMEAR THE SURFACE.
DO NOT USE LINT OR ABRASIVE CLOTHS AS THESE WILL SCRATCH THE SURFACE.
PLEASE USE A DAMP CLOTH (NOT WET) OR A LINT FREE CLOTH (OR MICROFIBRE TYPE CLOTH), AND ENSURE THAT YOU TEST THE CLOTH FIRST ON AN INCONSPICUOUS AREA OF THE FURNITURE BEFORE USE.

THE SURFACE OF THIS ITEM IS NOT HEAT RESISTANT. ALWAYS USE A PLACE MAT UNDER HOT OR COLD ITEMS TO PREVENT MARKING, AND SOFT FELT PADS UNDERNEATH ORNAMENTS.

CARE & MAINTENANCE INSTRUCTIONS

THIS PRODUCT INCLUDES TOUGHENED GLASS WITH NOMINAL THICKNESS 8/6/6MM IF THE GLASS IS CHIPPED OR BROKEN, PLEASE REPLACE WITH TYPE DESCRIBED OR ALTERNATIVELY CONSULT WITH THE RETAILER STATING THE MODEL DETAILS .

WARNING

1. MAXIMUM LOAD ON TOP - DO NOT EXCEED 40KGS IN WEIGHT.
2. DO NOT SIT OR STAND ON GLASS SURFACES.
3. DO NOT USE GLASS AS A CHOPPING SURFACE .
DO NOT STRIKE GLASS WITH HAND OR POINTED ITEMS.
4. DO NOT PLACE VERY HOT OR VERY COLD ITEMS ON THE GLASS SURFACES UNLESS ADEQUATELY THICK TABLE MATS ARE USED TO PREVENT SUCH ITEMS COMING INTO CONTACT WITH THE GLASS.
5. WHEN CLEANING GLASS PANELS USE A DAMP CLOTH OR LEATHER WITH WASHING UP LIQUID OR SOFT SOAP IF NECESSARY.
DO NOT USE WASHING POWDER OR ANY OTHER SUBSTANCES CONTAINING ABRASIVE SINCE THESE SUBSTANCES SCRATCH GLASS.

KEEP THESE INSTRUCTIONS IN A SAFE PLACE FOR FUTURE REFERENCE
THE GLASS USED IN THIS PRODUCT IS TOUGHENED AND CONFORMS TO BS 7376 2004

PLEASE CHECK THAT YOU HAVE ALL THE PARTS LISTED BEFORE YOU START ASSEMBLING. IF YOU DO FIND THAT SOMETHING IS MISSING. DO NOT CONTINUE ASSEMBLY. PLEASE CONTACT YOUR SUPPLIER IMMEDIATELY.

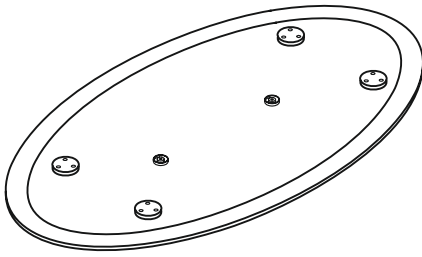

1

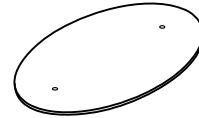

2



3



4

PARTS LIST

Part Number	Part Description	Quantity	Carton
1	Top Glass	1	1/2
2	Bottom Glass	1	1/2
3	Support Bar	2	2/2
4	Table Legs	4	2/2

HARDWARE LIST

REF		HARDWARE NAME	QTY
A		Metal Rod	2PCS
B		Plastic Cap	2PCS
C		Plastic Washer	2PCS
D		Flat Washer	2PCS
E		Nut	2PCS
F		Wrench Socket	1PC
G		Bolt	12PCS
H		Spring Washer	12PCS
I		Flat Washer	12PCS
J		Allen Key	1PC
K		Adjustable Feet	4PCS

STEP 1

PARTS REQUIRED

1 - TOP GLASS x1

HARDWARE REQUIRED

A  02

TOOLS REQUIRED

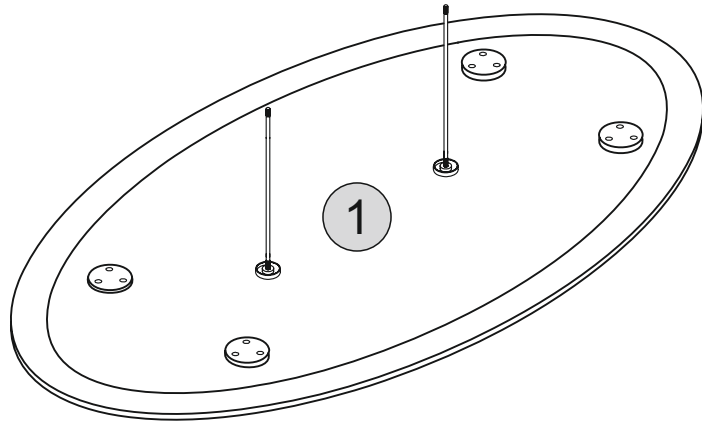
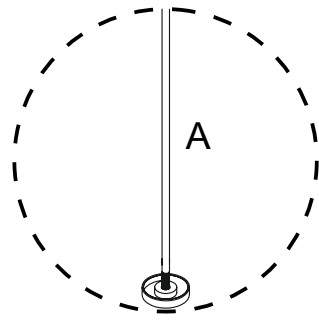

STEP 2

PARTS REQUIRED

3 - SUPPORT BAR x2

HARDWARE REQUIRED

B  02

TOOLS REQUIRED

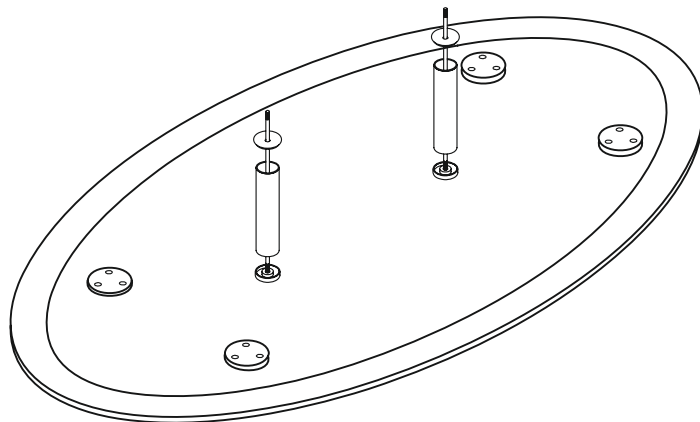
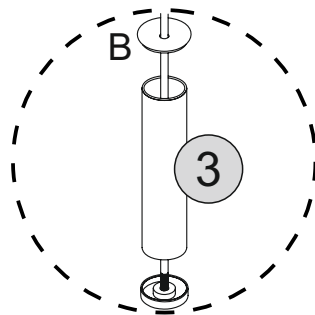
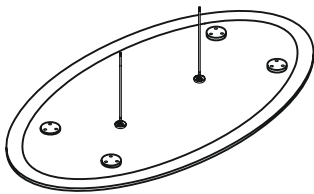

STEP 3

PARTS REQUIRED

2 - BOTTOM GLASS x1

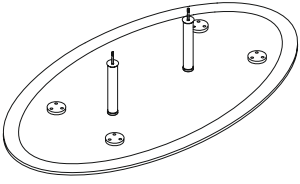

HARDWARE REQUIRED

C  02

D  02

E  02

TOOLS REQUIRED

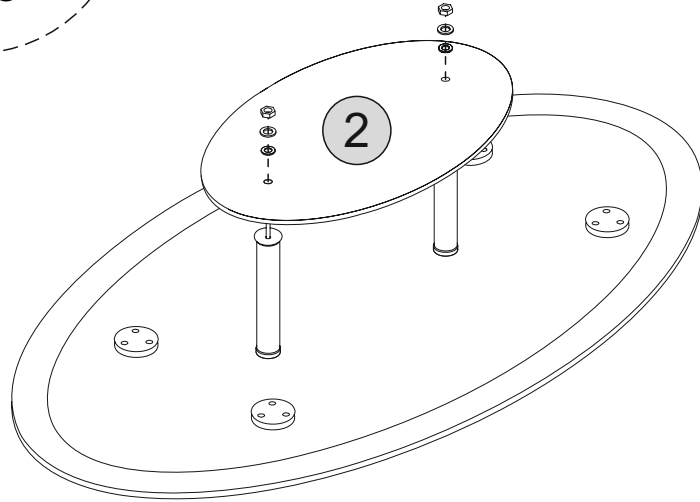
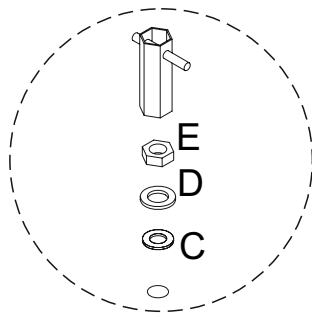
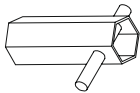

STEP 4

PARTS REQUIRED

4 - TABLE LEGS x4

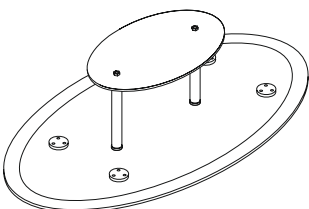

HARDWARE REQUIRED

G  12

H  12

I  12

TOOLS REQUIRED

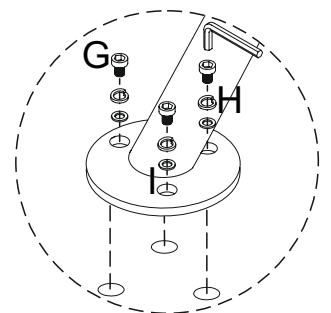
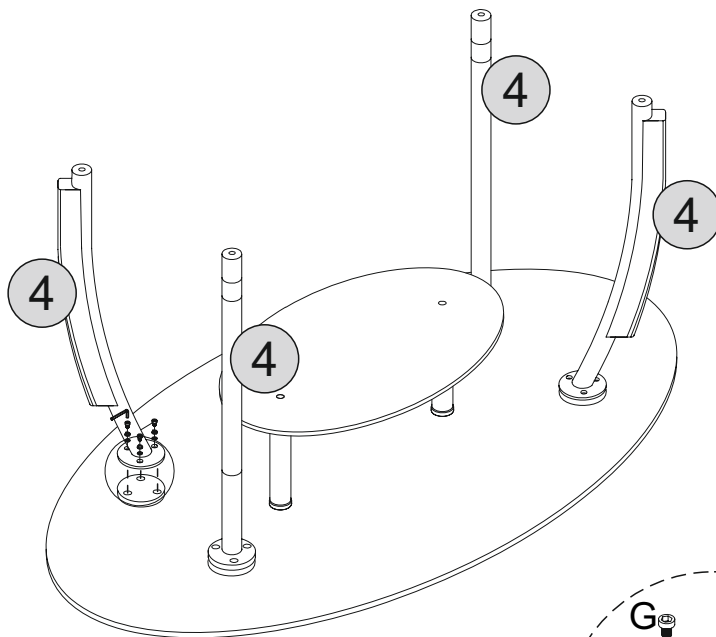
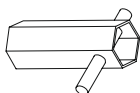

STEP 5

PARTS REQUIRED

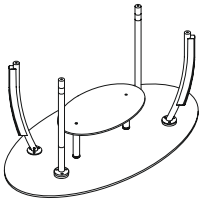

HARDWARE REQUIRED



TOOLS REQUIRED

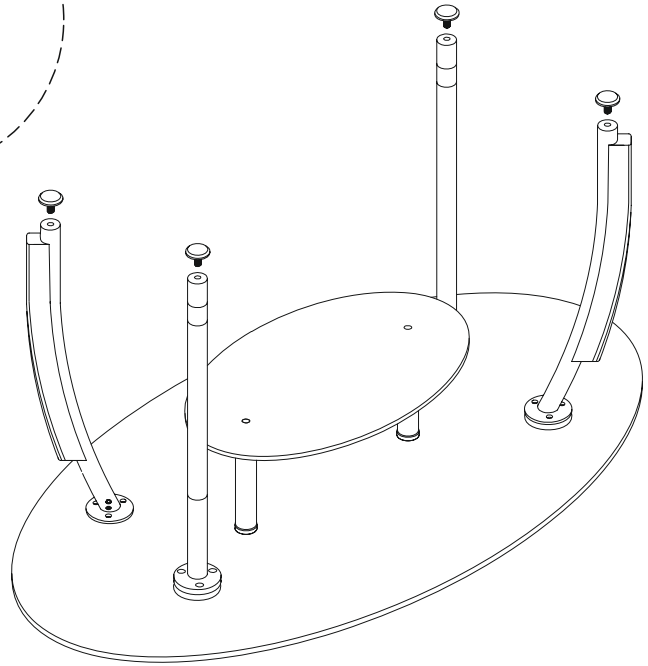
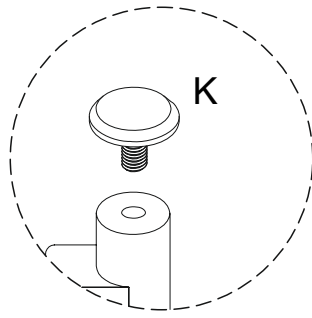

STEP 6

PARTS REQUIRED

HARDWARE REQUIRED

TOOLS REQUIRED

