

# CORONA NEST OF TABLES ASSEMBLY INSTRUCTIONS

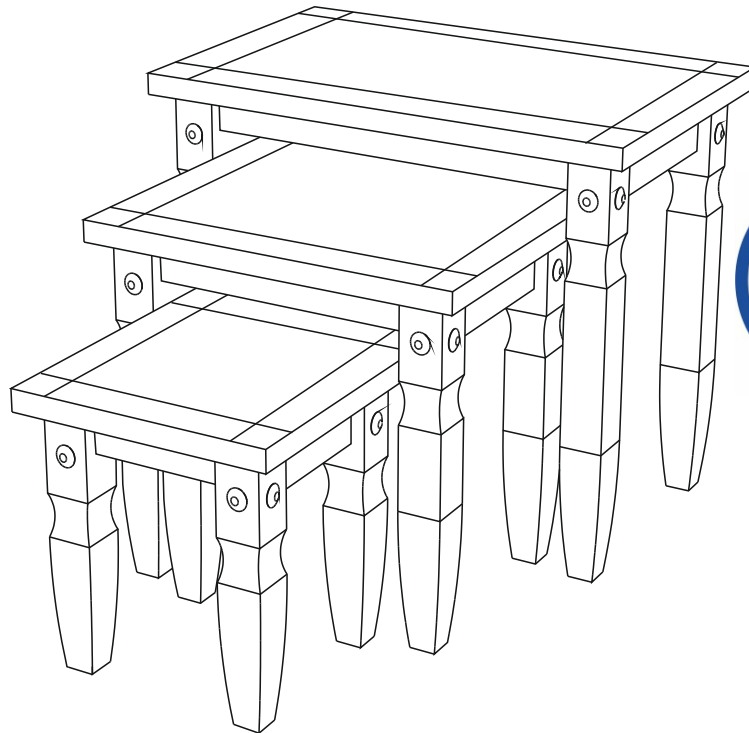

## **IMPORTANT** PLEASE READ BEFORE YOU CONTINUE FURTHER **FOR DOMESTIC USE ONLY** **CARE AND MAINTENANCE**

After unpacking this product please keep the original packaging in case it needs to be returned for any reason.

- Please ensure all fittings and parts are present before commencing with assembly.
- We recommend that you lay a blanket or sheet on the floor to avoid damage to both your floor and the product.
- We strongly recommend that you keep children away from your work area.
- Assemble this product as close to its final position as possible.
- Never drag or push products as this could cause damage to the joints making it inferior.
- Do not place this product next to a radiator or in direct sunlight.
- Wood is a natural product and may expand if subjected to damp and may shrink or crack if subjected to heat. Therefore it is recommended that room temperature is maintained, with no sudden temperature fluctuations.
- Make sure any spillage is wiped off immediately.
- Do not place hot or chilled items directly on to the surface, use a place mat or marking will occur.
- For general cleaning use a duster, and do not use detergents of any kind. However, the surface will need to be retreated from time to time. This can be done by using block wax (unperfumed) and rubbing it over the whole item.
- From time to time it may be necessary to tighten fittings, regular inspections should be carried out.

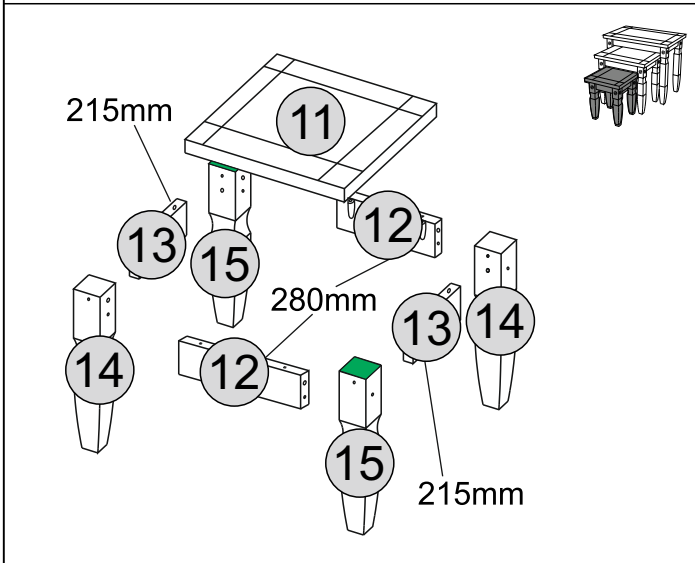
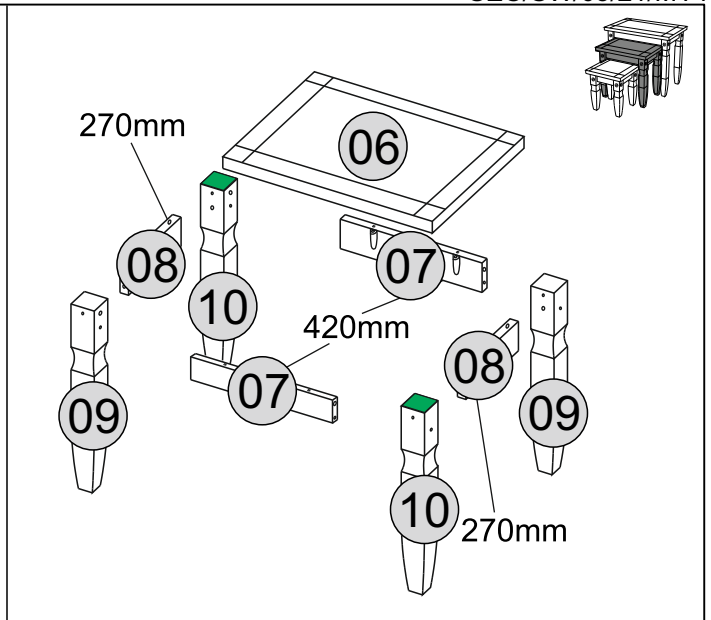
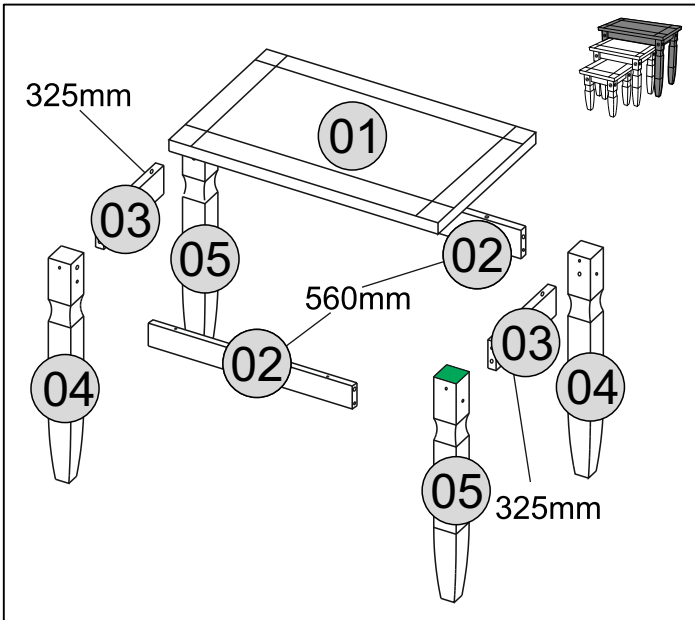



**!**



- \* Use of power tools to assemble this product will invalidate any claim and damage this product making it unsafe !!!
- \* Please assemble on a clean soft surface to avoid damage.
- \* Please check carton contents and read the instructions before commencing assembly.
- \* Assemble this product following the enclosed instructions carefully.
- \* Please take care to avoid damaging panels during assembly.

### PARTS LIST

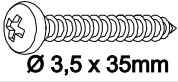
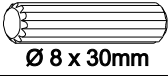
| Part Number | Part Code           | Part Description                  | Quantity | Carton |
|-------------|---------------------|-----------------------------------|----------|--------|
| 01          | S300-303-010-MY1-01 | Top Panel (Large)                 | 1        | 1/1    |
| 02          | S300-303-010-MY1-02 | Front/Rear Panel (Large) (560mm)  | 2        | 1/1    |
| 03          | S300-303-010-MY1-03 | Side Panel (Large) (325mm)        | 2        | 1/1    |
| 04          | S300-303-010-MY1-04 | Leg Natural (Large)               | 2        | 1/1    |
| 05          | S300-303-010-MY1-05 | Leg Green (Large)                 | 2        | 1/1    |
| 06          | S300-303-010-MY1-06 | Top Panel (Medium)                | 1        | 1/1    |
| 07          | S300-303-010-MY1-07 | Front/Rear Panel (Medium) (420mm) | 2        | 1/1    |
| 08          | S300-303-010-MY1-08 | Side Panel (Medium) (270mm)       | 2        | 1/1    |
| 09          | S300-303-010-MY1-09 | Leg Natural (Medium)              | 2        | 1/1    |
| 10          | S300-303-010-MY1-10 | Leg Green (Medium)                | 2        | 1/1    |
| 11          | S300-303-010-MY1-11 | Top Panel (Small)                 | 1        | 1/1    |
| 12          | S300-303-010-MY1-12 | Front/Rear Panel (Small) (280mm)  | 2        | 1/1    |
| 13          | S300-303-010-MY1-13 | Side Panel (Small) (215mm)        | 2        | 1/1    |
| 14          | S300-303-010-MY1-14 | Leg Natural (Small)               | 2        | 1/1    |
| 15          | S300-303-010-MY1-15 | Leg Green (Small)                 | 2        | 1/1    |

### FITTINGS

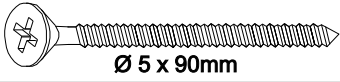
|   |                                                                                                       |    |
|---|-------------------------------------------------------------------------------------------------------|----|
| A |  <p>Ø 3,5 x 35mm</p> | 16 |
| B |  <p>Ø 8 x 30mm</p>   | 36 |
| C |                      | 24 |

|   |                                                                                                      |    |
|---|------------------------------------------------------------------------------------------------------|----|
| D |  <p>Ø 5 x 90mm</p> | 24 |
| E |  <p>GLUE</p>      | 02 |

### TOOLS REQUIRED

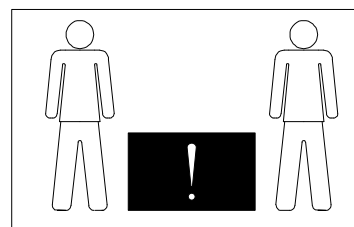
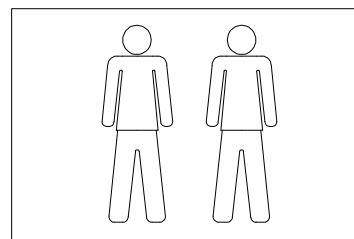
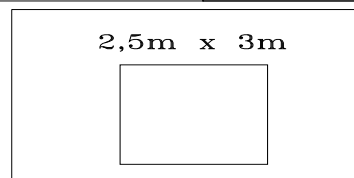
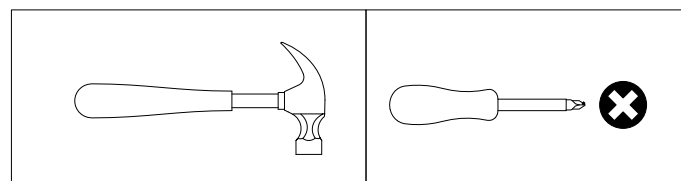

# STEP 1

## PARTS REQUIRED

02-FRONT/REAR PANEL (LARGE)(560mm) x2

07-FRONT/REAR PANEL (MEDIUM)(420mm)x2

12-FRONT/REAR PANEL (SMALL)(280mm) x2

## HARDWARE REQUIRED

B  12  
Ø 8 x 30mm

E  01  
GLUE

## TOOLS REQUIRED

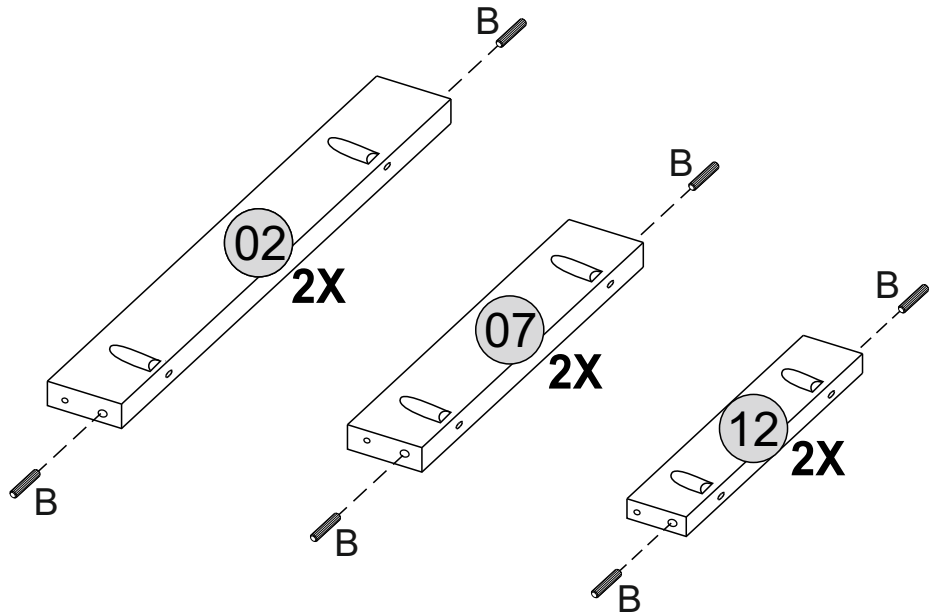

  
Please assemble on a clean soft surface to avoid damage.

  
Glue must be added to the dowel holes on part 02, 07, 12.

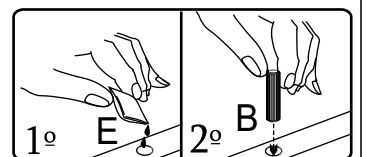

# STEP 2

## PARTS REQUIRED

03 - SIDE PANEL (LARGE)(325mm) x2

08 - SIDE PANEL (MEDIUM)(270mm) x2

13 - SIDE PANEL (SMALL)(215mm) x2

## HARDWARE REQUIRED

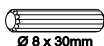
B  24  
Ø 8 x 30mm

E  01  
GLUE

## TOOLS REQUIRED

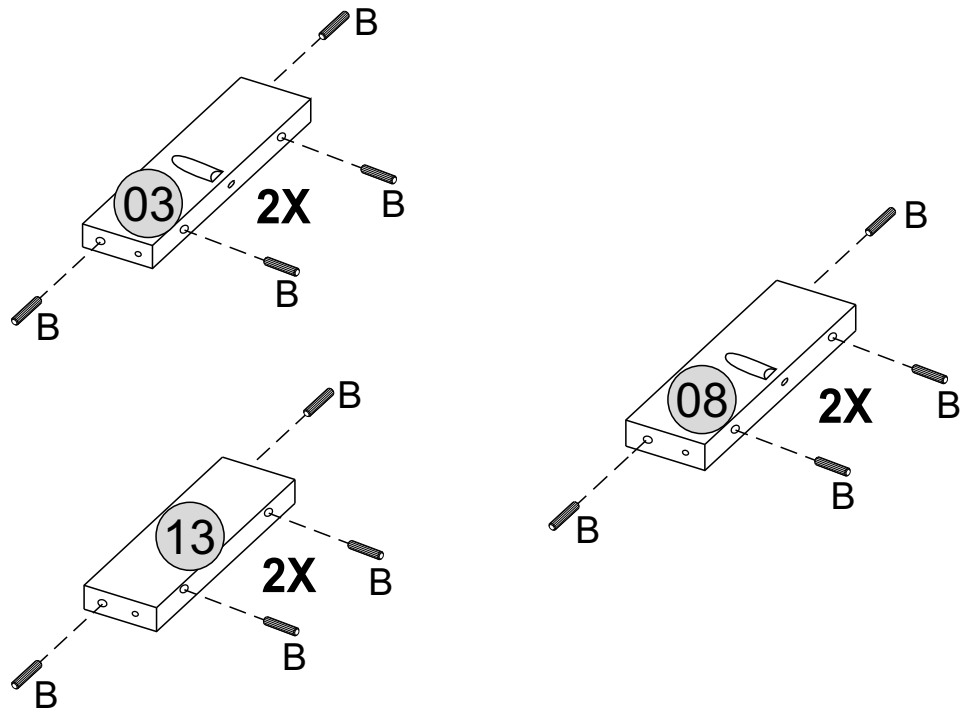

  
Please assemble on a clean soft surface to avoid damage.

  
Glue must be added to the dowel holes on part 03, 08, 13.

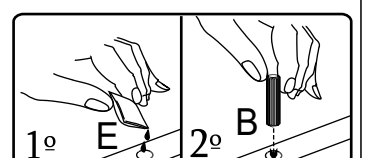

# STEP 3

## PARTS REQUIRED

02-FRONT/REAR PANEL (LARGE)(560mm) x2

04-LEG NATURAL (LARGE) x2

05-LEG GREEN (LARGE) x2

## HARDWARE REQUIRED

D  04  
Ø 5 x 90mm

E  01

## TOOLS REQUIRED

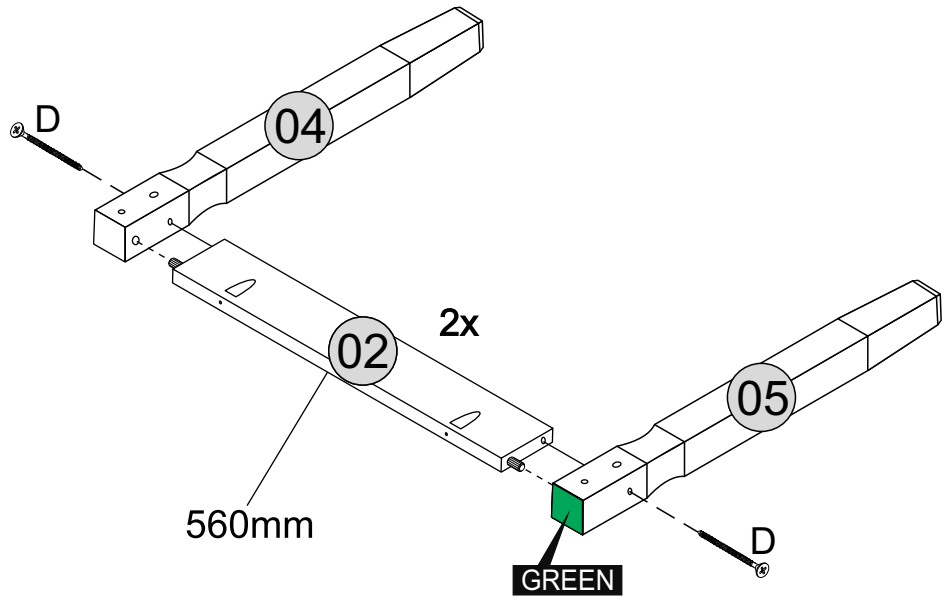
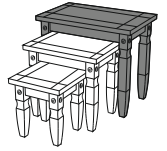
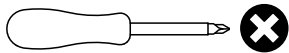

Please assemble on a clean soft surface to avoid damage.



Glue must be added to the dowel holes on part 04 and 05.

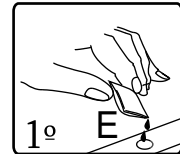

# STEP 4

## PARTS REQUIRED

03 - SIDE PANEL (LARGE)(325mm) x2

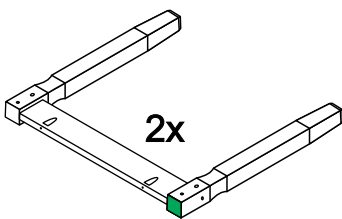

## HARDWARE REQUIRED

D  04  
Ø 5 x 90mm

E  01

## TOOLS REQUIRED

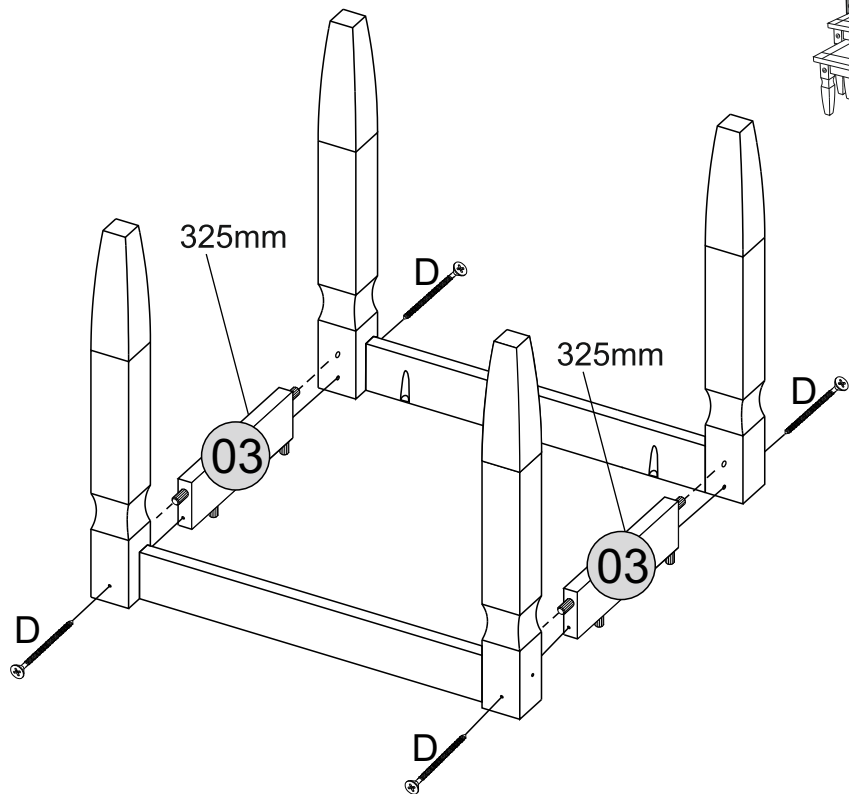
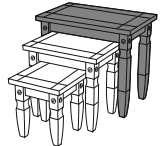
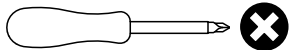

Please assemble on a clean soft surface to avoid damage.



Glue must be added to the dowel holes on part 04 and 05.

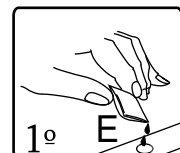

# STEP 5

## PARTS REQUIRED

01 - TOP PANEL (LARGE) x1

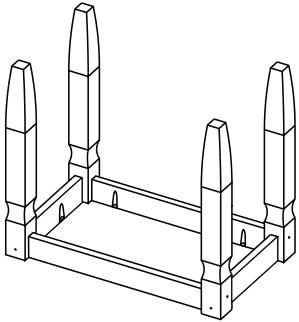

## HARDWARE REQUIRED

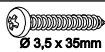
A  06  
Ø 3,5 x 35mm

E  01

## TOOLS REQUIRED

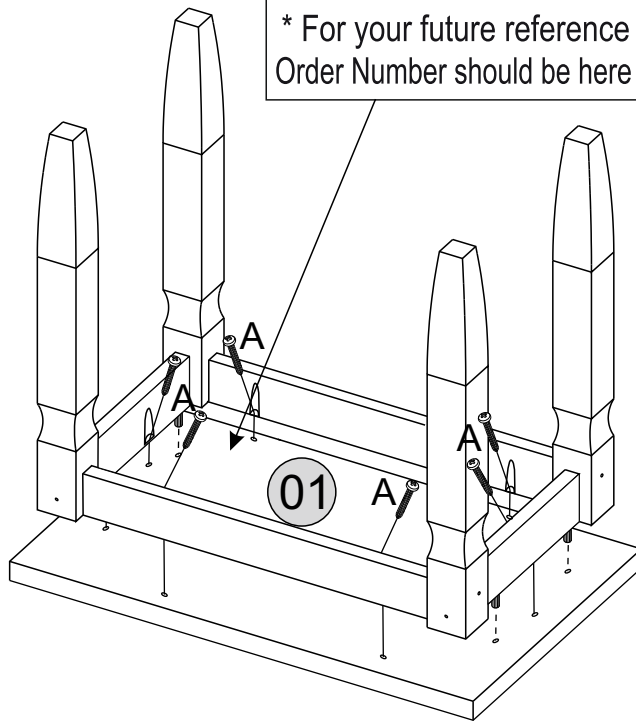
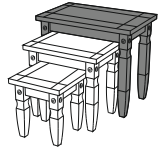
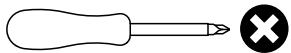

\* For your future reference  
Order Number should be here



Please assemble on a clean soft surface to avoid damage.



Glue must be added to the dowel holes on part 01.

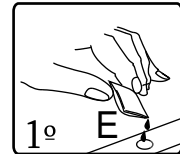

# STEP 6

## PARTS REQUIRED

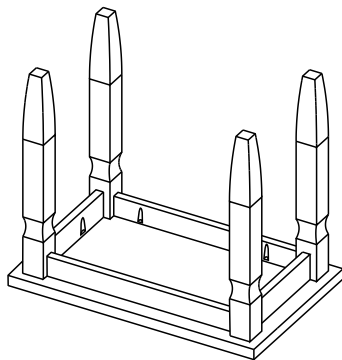

## HARDWARE REQUIRED

C  08

## TOOLS REQUIRED

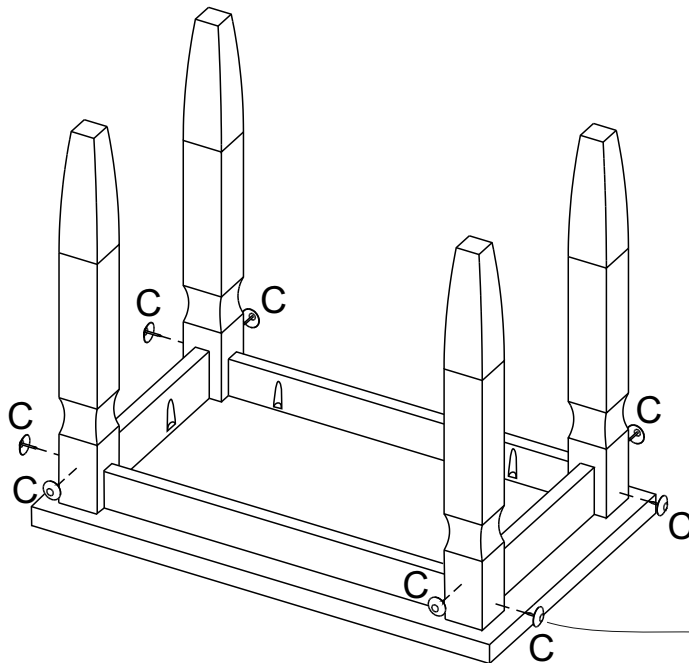
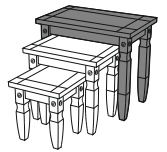

Please assemble on a clean soft surface to avoid damage.

**IMPORTANT:** Please insert the studs as per the illustration above, 1 stud above the screw and 1 stud below so that both studs line up.

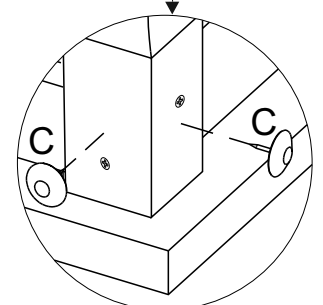

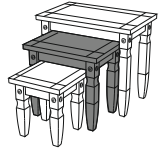

# STEP 7

## PARTS REQUIRED

07-FRONT/REAR PANEL (MEDIUM)(420mm)x2

09- LEG NATURAL (MEDIUM) x2

10- LEG GREEN (MEDIUM) x2

## HARDWARE REQUIRED

D  04  
Ø 5 x 90mm

E  01

## TOOLS REQUIRED

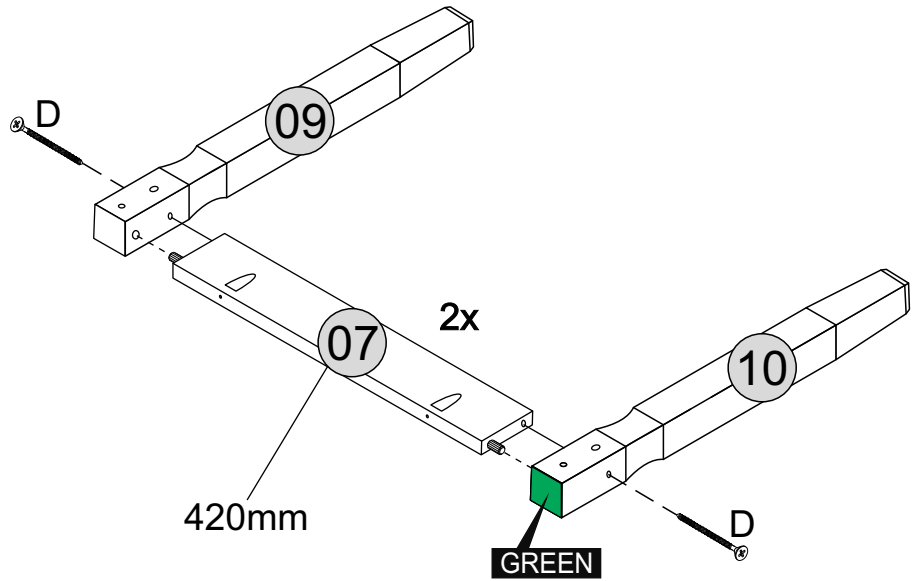
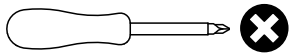

Please assemble on a clean soft surface to avoid damage.



Glue must be added to the dowel holes on part 09 and 10.

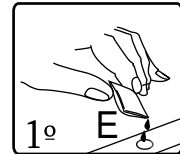

# STEP 8

## PARTS REQUIRED

08 - SIDE PANEL (MEDIUM)(270mm) x2

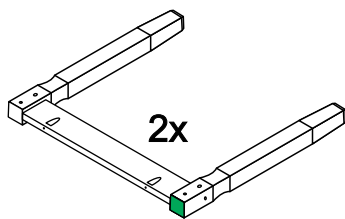

## HARDWARE REQUIRED

D  04  
Ø 5 x 90mm

E  01

## TOOLS REQUIRED

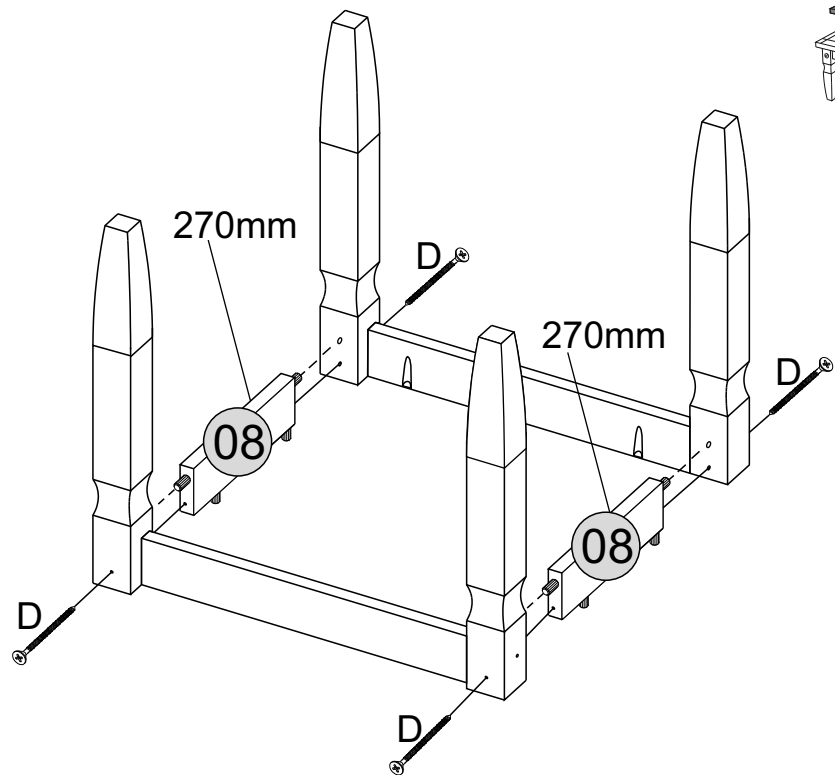
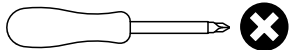

Please assemble on a clean soft surface to avoid damage.



Glue must be added to the dowel holes on part 09 and 10.

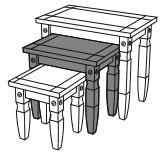
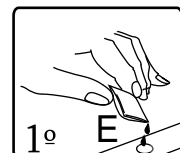

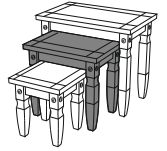

# STEP 9

## PARTS REQUIRED

06 - TOP PANEL (MEDIUM) x1

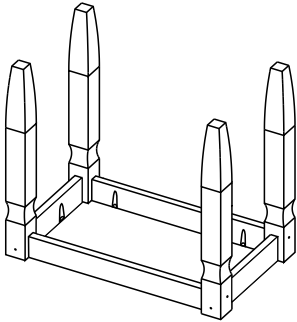

## HARDWARE REQUIRED

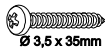
A  06  
Ø 3,5 x 35mm

E  01  
GLUE

## TOOLS REQUIRED

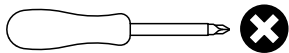

\* For your future reference  
Order Number should be here

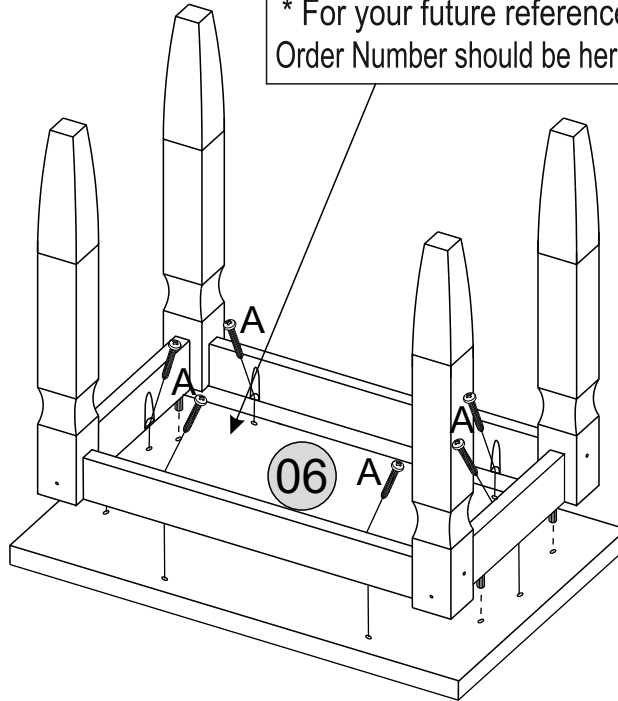

Please assemble on  
a clean soft surface  
to avoid damage.



Glue must be added to the  
dowel holes on part  
06.

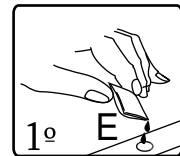

# STEP 10

## PARTS REQUIRED

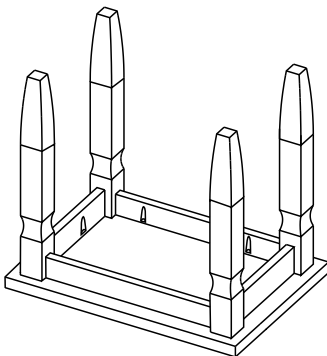

## HARDWARE REQUIRED

C  08

## TOOLS REQUIRED

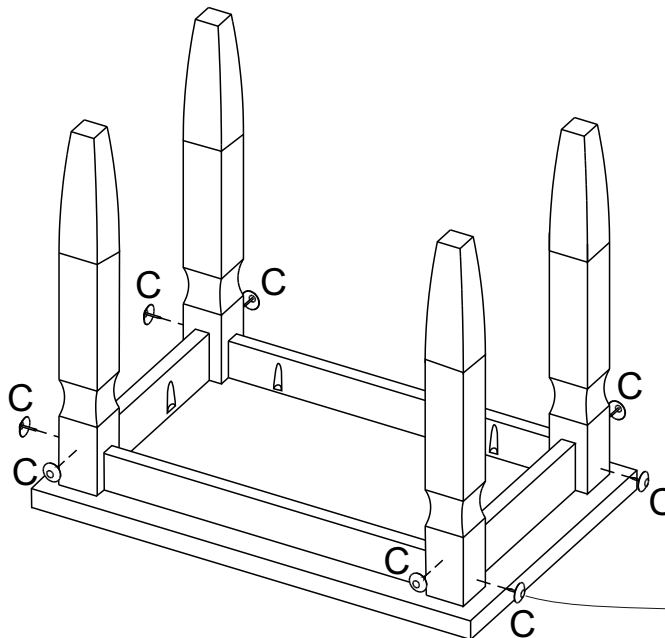
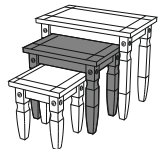

Please assemble on  
a clean soft surface  
to avoid damage.

**IMPORTANT:** Please insert the studs  
as per the illustration above, 1 stud  
above the screw and 1 stud below so  
that both studs line up.

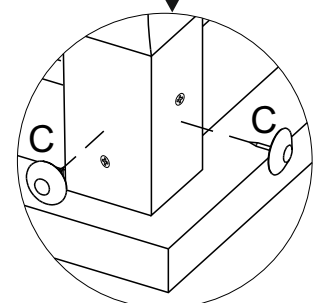



# STEP 11

## PARTS REQUIRED

12- FRONT/REAR PANEL (SMALL)(280mm) x2

14- LEG NATURAL (SMALL) x2

15- LEG GREEN (SMALL) x2

## HARDWARE REQUIRED

D  04  
Ø 5 x 90mm

E  01

## TOOLS REQUIRED

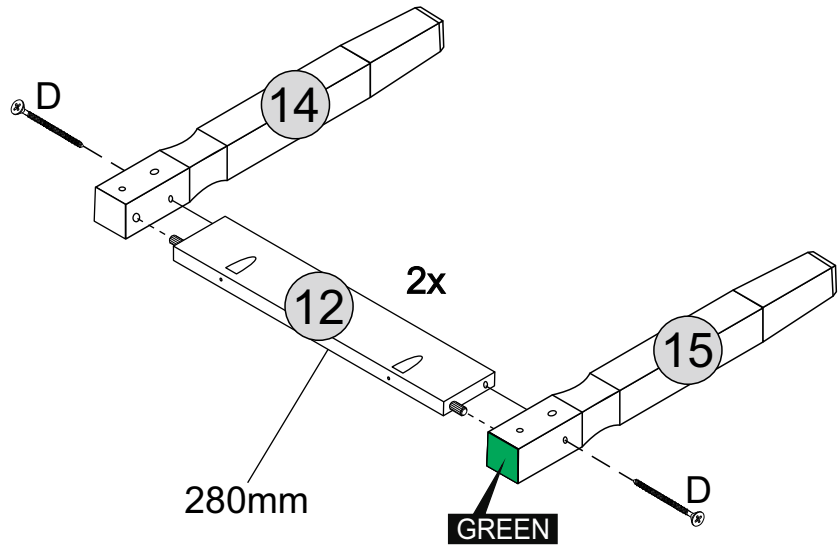
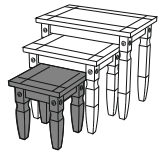
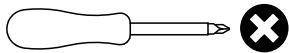

Please assemble on a clean soft surface to avoid damage.



Glue must be added to the dowel holes on part 14 and 15.

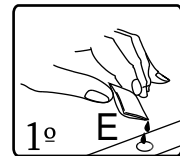

# STEP 12

## PARTS REQUIRED

13 - SIDE PANEL (SMALL)(215mm) x2

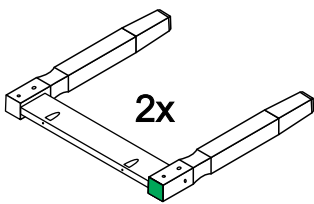

## HARDWARE REQUIRED

D  04  
Ø 5 x 90mm

E  01

## TOOLS REQUIRED

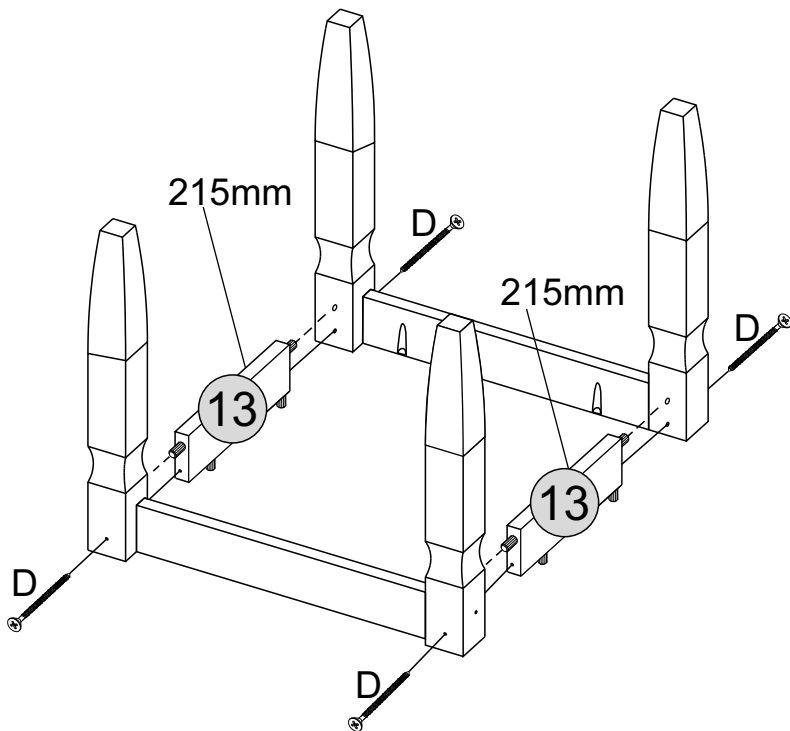
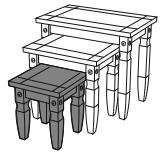
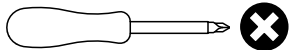

Please assemble on a clean soft surface to avoid damage.



Glue must be added to the dowel holes on part 14 and 15.

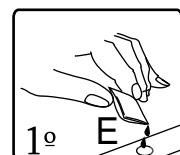

# STEP 13

## PARTS REQUIRED

11 - TOP PANEL (SMALL) x1

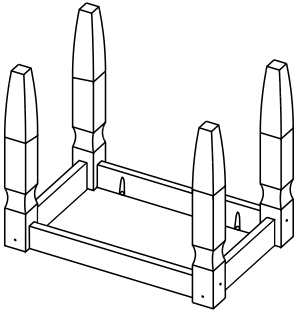

## HARDWARE REQUIRED

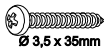
A  06  
Ø 3,5 x 35mm

E  01  
GLUE

## TOOLS REQUIRED

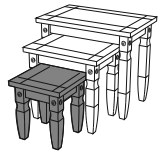
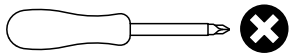

\* For your future reference  
Order Number should be here

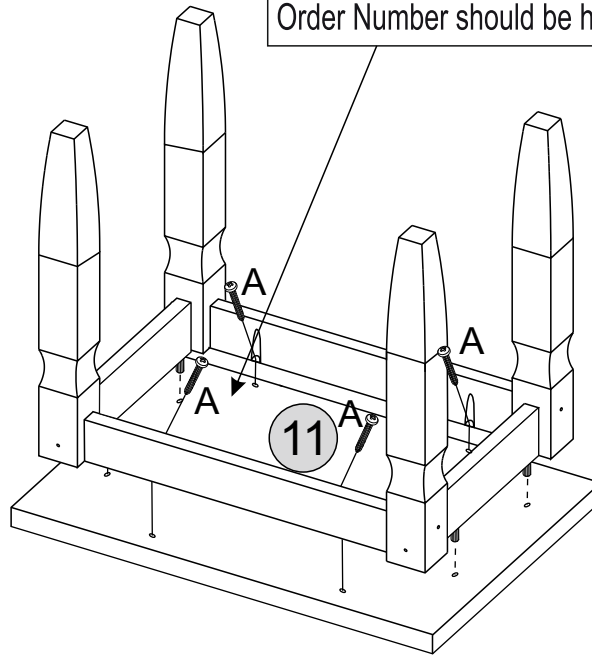

Please assemble on  
a clean soft surface  
to avoid damage.



Glue must be added to the  
dowel holes on part  
11.

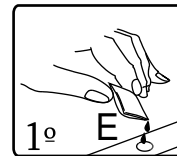

# STEP 14

## PARTS REQUIRED

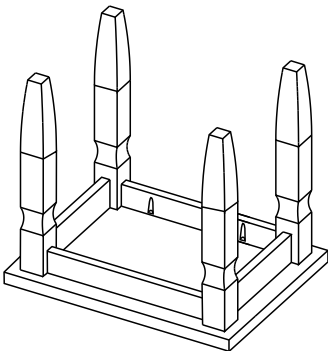

## HARDWARE REQUIRED

C  08

## TOOLS REQUIRED

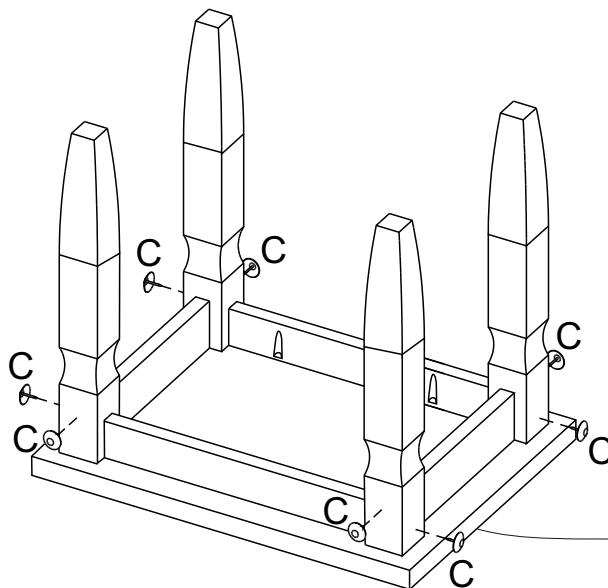
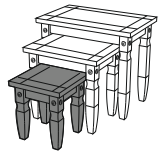

Please assemble on  
a clean soft surface  
to avoid damage.

**IMPORTANT:** Please insert the studs  
as per the illustration above, 1 stud  
above the screw and 1 stud below so  
that both studs line up.

