

NORDIC 1 DOOR 2 DRAWER TV UNIT ASSEMBLY INSTRUCTIONS

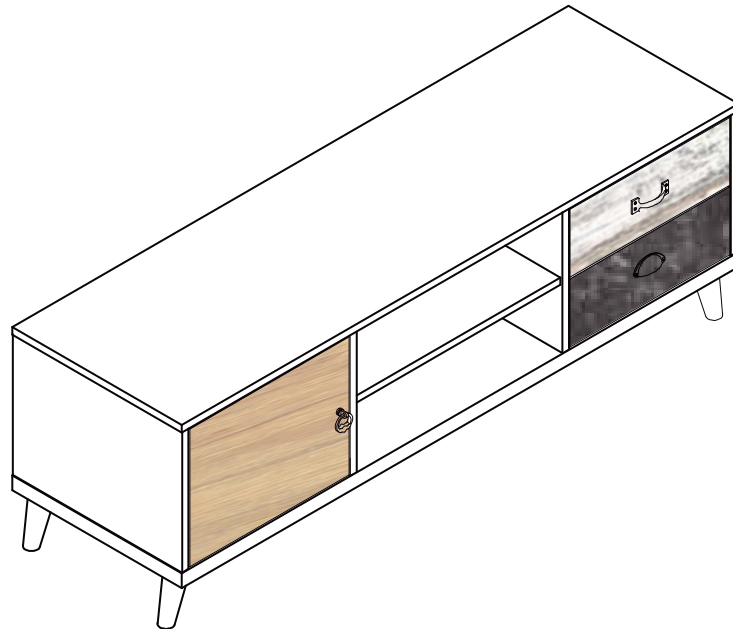

FOR DOMESTIC USE ONLY

IMPORTANT

PLEASE READ BEFORE YOU CONTINUE FURTHER

THE PRODUCT YOU HAVE PURCHASED WILL GIVE YOU MANY YEARS OF SERVICE IF YOU FOLLOW THE GUIDELINES FOR ITS SAFE ASSEMBLY AND PERIODIC MAINTENANCE AND CLEANING.

ASSEMBLE ON A SOFT CLEAN SURFACE.

DO NOT USE ANY TOOLS OTHER THAN THOSE SHOWN.

ANY SPANNERS OR ALLEN KEYS REQUIRED ARE INCLUDED WITH THE FITTING KIT.

DO NOT FOR ANY REASON USE A POWER TOOL TO ASSEMBLE THIS PRODUCT. ITS USE WILL INVALIDATE ANY CLAIM YOU MAY HAVE AND COULD MAKE THIS PRODUCT UNSAFE.

DEPENDING ON THE AMOUNT OF USE THIS PRODUCT RECEIVES, IT MAY BE NECESSARY TO TIGHTEN UP THE FIXINGS FROM TIME TO TIME. THIS IS COMPLETELY NORMAL FOR ANY FLAT PACK FURNITURE. DO NOT OVERTIGHTEN FIXINGS.

FOR CLEANING, YOU MAY USE A DAMP CLOTH (NOT WET). DO NOT USE POLISH, DETERGENT OR CHEMICAL CLEANERS.



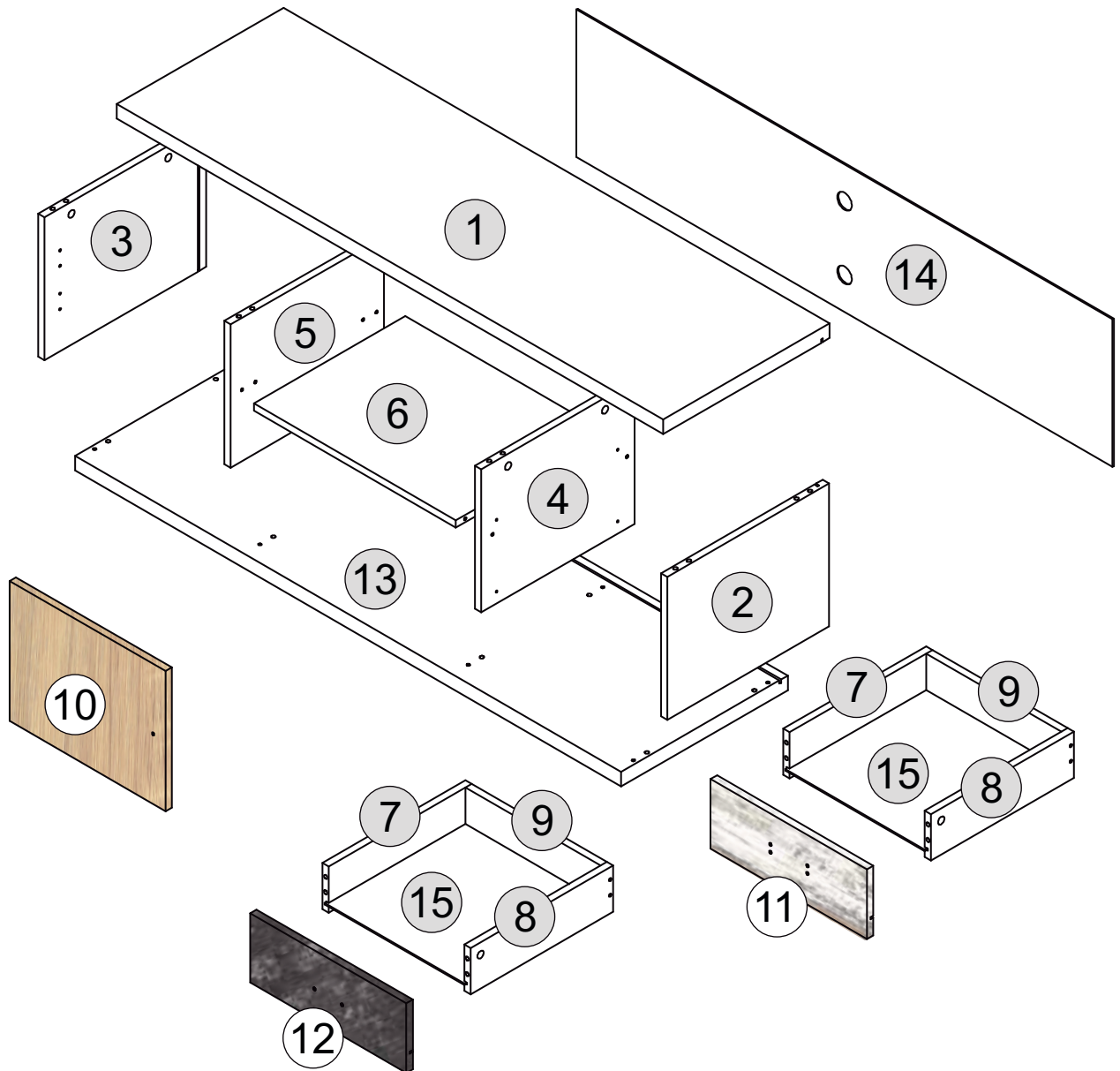











THIS SURFACE OF THIS ITEM IS NOT HEAT RESISTANT. ALWAYS USE A PLACE MAT UNDER HOT OR COLD ITEMS TO PREVENT MARKING.



PART LIST

Part Number	Part Code	Part Description	Quantity	Carton
1	S300-305-045-ZF1-01	Top Panel	1	1/1
2	S300-305-045-ZF1-02	Right Side Panel	1	1/1
3	S300-305-045-ZF1-03	Left Side Panel	1	1/1
4	S300-305-045-ZF1-04	Right Centre Panel	1	1/1
5	S300-301-045-ZF1-05	Left Centre Panel	1	1/1
6	S300-301-045-ZF1-06	Shelf Panel	1	1/1
7	S300-301-045-ZF1-07	Left Drawer Side	2	1/1
8	S300-301-045-ZF1-08	Right Drawer Side	2	1/1
9	S300-301-045-ZF1-09	Drawer Back	2	1/1
10	S300-301-045-ZF1-10	Door	1	1/1
11	S300-301-045-ZF1-11	Top Drawer Front	1	1/1
12	S300-301-045-ZF1-12	Bottom Drawer Front	1	1/1
13	S300-301-045-ZF1-13	Bottom Panel	1	1/1
14	S300-301-045-ZF1-14	Back Panel	1	1/1
15	S300-301-045-ZF1-15	Drawer Base	2	1/1

HARDWARE LIST

No	Part Name		Qty	Carton
A	M8x25mm Wooden Dowel		x24	1
B	M4x45mm Screw		x4	1
C	M4x38mm Screw		x8	1
D	M3.5x14mm Screw		x40	1
E	Minifix Cam Bolt (8032t)		x12	1
F	Minifix Cam Nut (1512)		x12	1
G	Wood Leg + Plastic Foot		x4	1
H	End Hinges (M11)		x2	1
I	14"Drawer Slide (0.9 - W)		x2	1
J	Handle + Screw (L-3510 (3x16mm=4pcs))		x1	1
K	Handle + Screw (Y-8238 (3x16mm=2pcs))		x1	1
L	Handle + Screw (T-4538 (4x20mm=1pcs))		x1	1
M	Door Stopper (AC89-BLK)		x1	1
N	6/8" Nail		x6	1
O	4x65mm Screw		x8	1

TIPS FOR FITTINGS CAM-LOCKS

WHEN FITTING CAM NUT. ENSURE STARTING POSITION IS CORRECT BEFORE YOU INSERT CONNECTING CAM BOLT TURN CLOCKWISE UNTIL SECURE



CORRECT **WRONG**

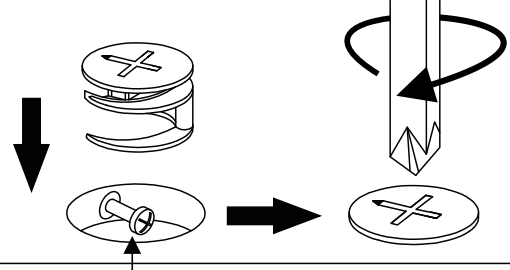

Cam bolt head needs to be in centre

CAMBOLT

Tighten until shoulder in flush with panel. Do not overtighten or undertighten (see example below)

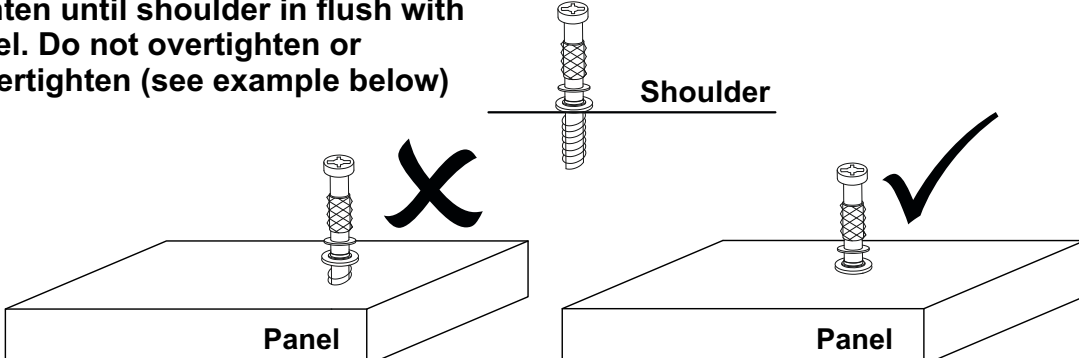

Shoulder



Panel **Panel**

STEP 1

PARTS REQUIRED

- 1 - TOP PANEL x1
- 6 - SHELF PANEL x1

HARDWARE REQUIRED

- A  04
- E  08
- M  01

TOOLS REQUIRED

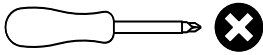

WHEN FITTING CAM BOLT
ENSURE THE CAM STUD IS FULLY TIGHTEN IN

CORRECT WRONG

WHEN FITTING CAMS
ENSURE STARTING POSITION IS CORRECT BEFORE YOU INSERT CONNECTING BOLT. TURN CLOCKWISE UNTIL SECURE

CORRECT WRONG

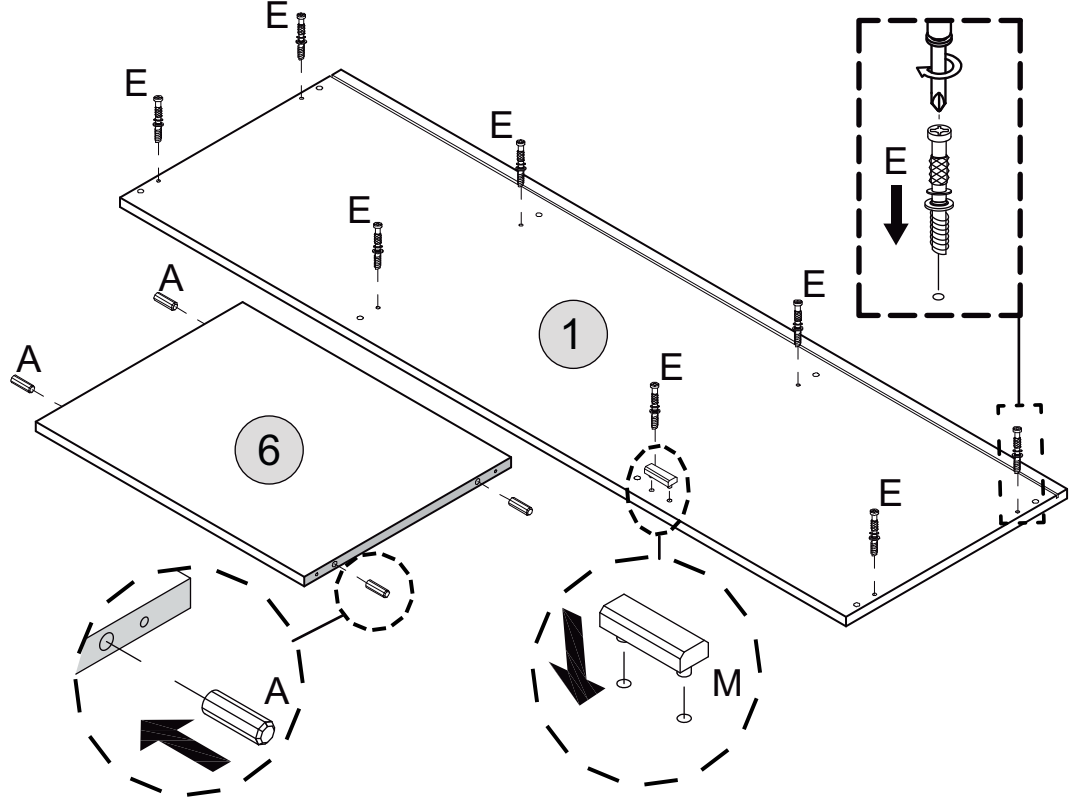



STEP 2

PARTS REQUIRED

- 2 - RIGHT SIDE PANEL x1
- 3 - LEFT SIDE PANEL x1
- 4 - RIGHT CENTRE PANEL x1
- 5 - LEFT CENTRE PANEL x1

HARDWARE REQUIRED

- A  16
- F  08

TOOLS REQUIRED

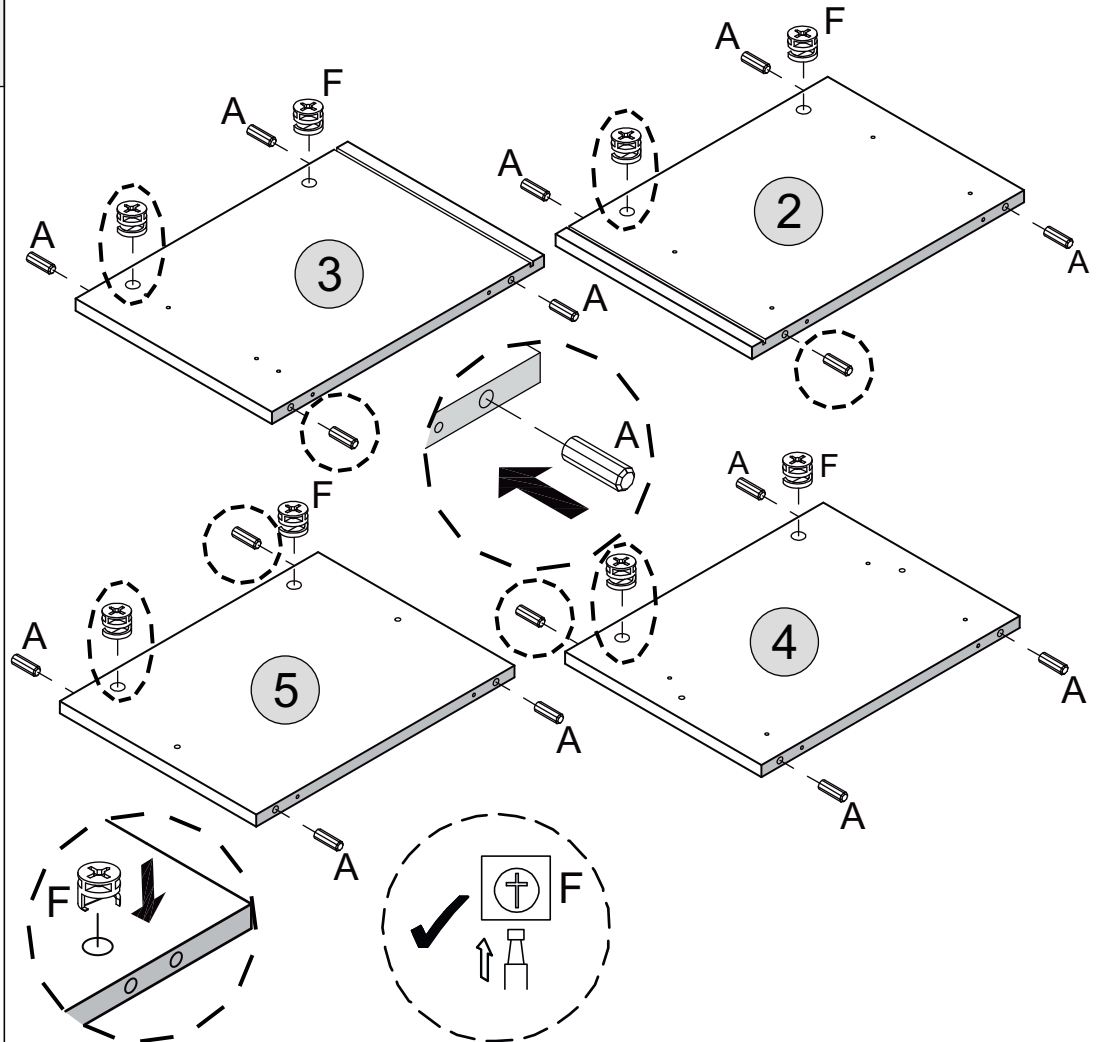

STEP 3

PARTS REQUIRED

2 - RIGHT SIDE PANEL x1

4 - RIGHT CENTRE PANEL x1

HARDWARE REQUIRED

D  08

I  04

TOOLS REQUIRED

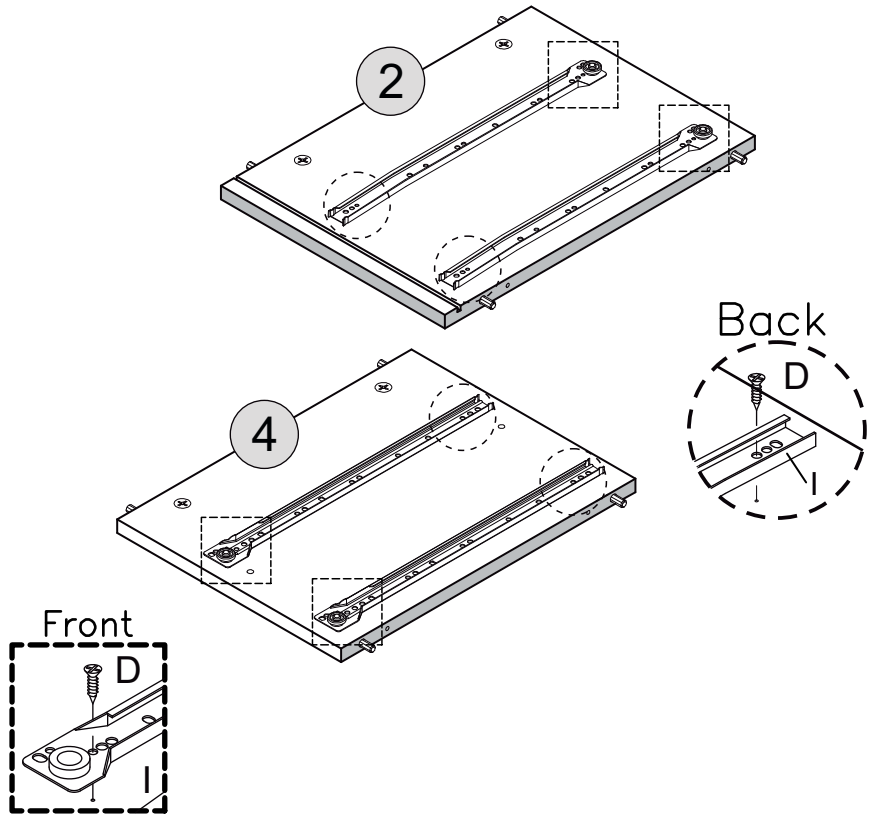
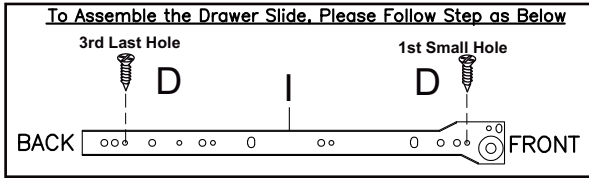
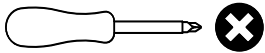

STEP 4

PARTS REQUIRED

4 - RIGHT CENTRE PANEL x1

5 - LEFT CENTRE PANEL x1

6 - SHELF PANEL x1

HARDWARE REQUIRED

B  04

TOOLS REQUIRED

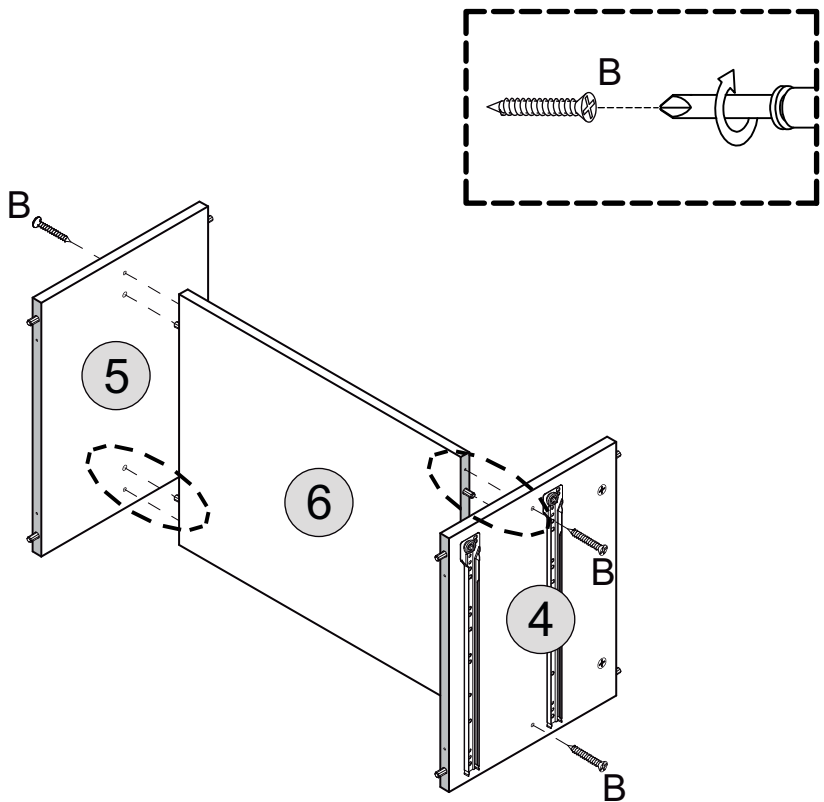
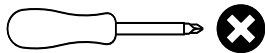

STEP 5

PARTS REQUIRED

- 1 - TOP PANEL x1
- 2 - RIGHT SIDE PANEL x1
- 3 - LEFT SIDE PANEL x1

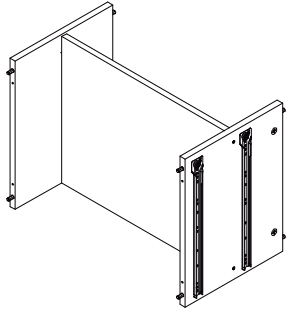

HARDWARE REQUIRED

TOOLS REQUIRED

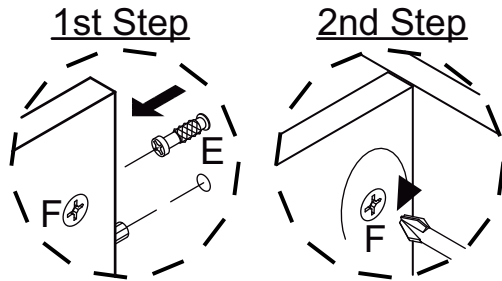
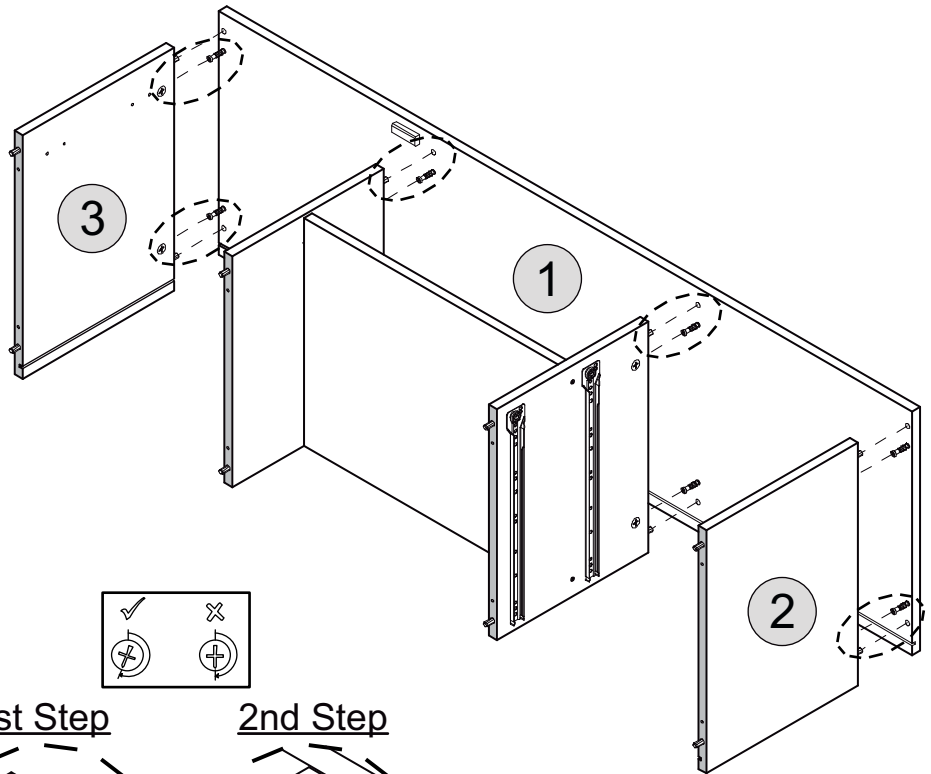
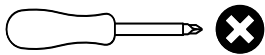

STEP 6

PARTS REQUIRED

- 14 - BACK PANEL x1

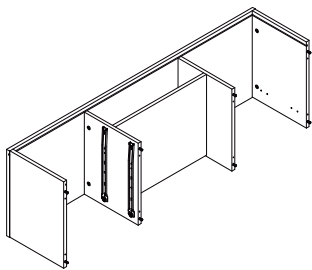

HARDWARE REQUIRED

TOOLS REQUIRED

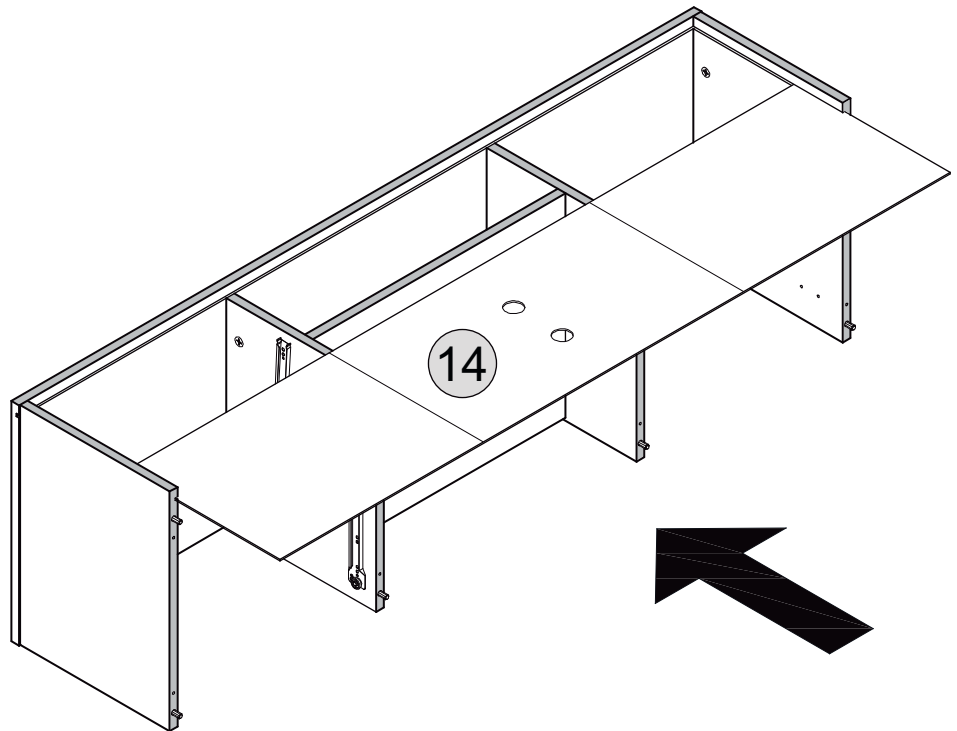

STEP 7

PARTS REQUIRED

13 - BOTTOM PANEL x1

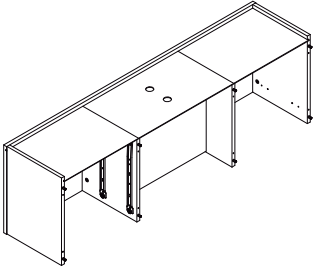

HARDWARE REQUIRED

O  08

TOOLS REQUIRED

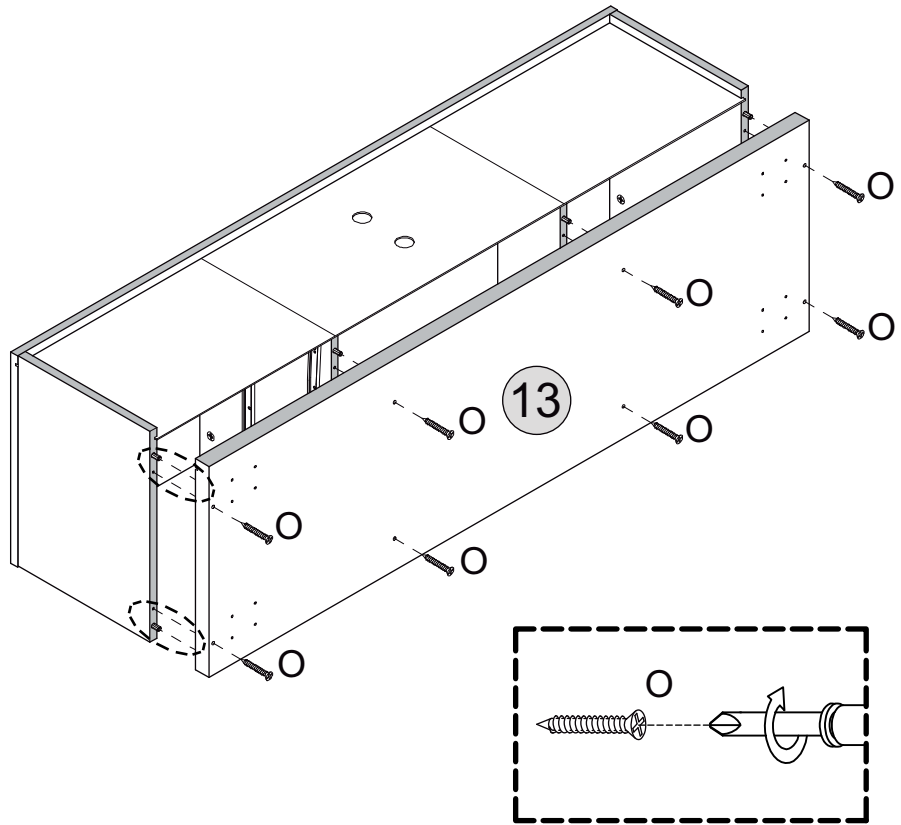
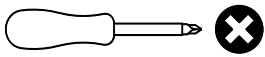

STEP 8

PARTS REQUIRED

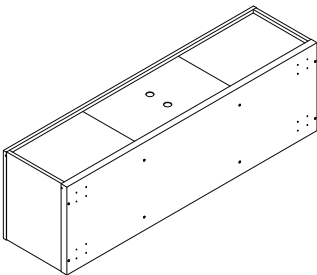

HARDWARE REQUIRED

N  06

TOOLS REQUIRED

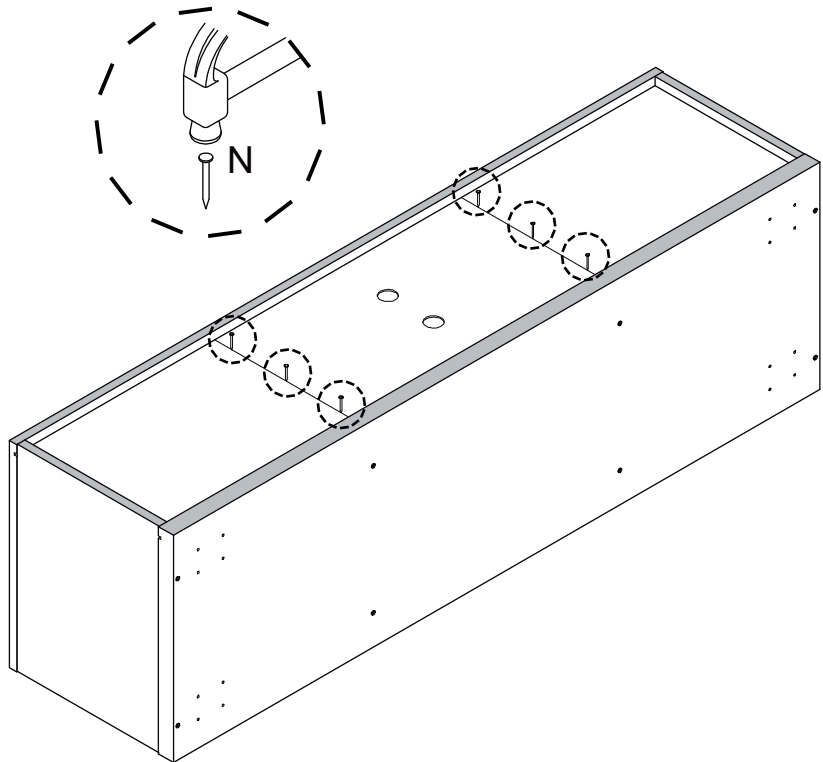
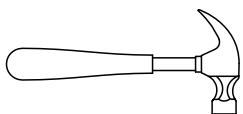

STEP 9

PARTS REQUIRED

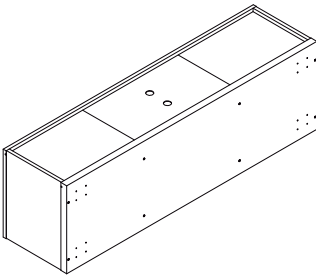

HARDWARE REQUIRED

D		16
G		04

TOOLS REQUIRED

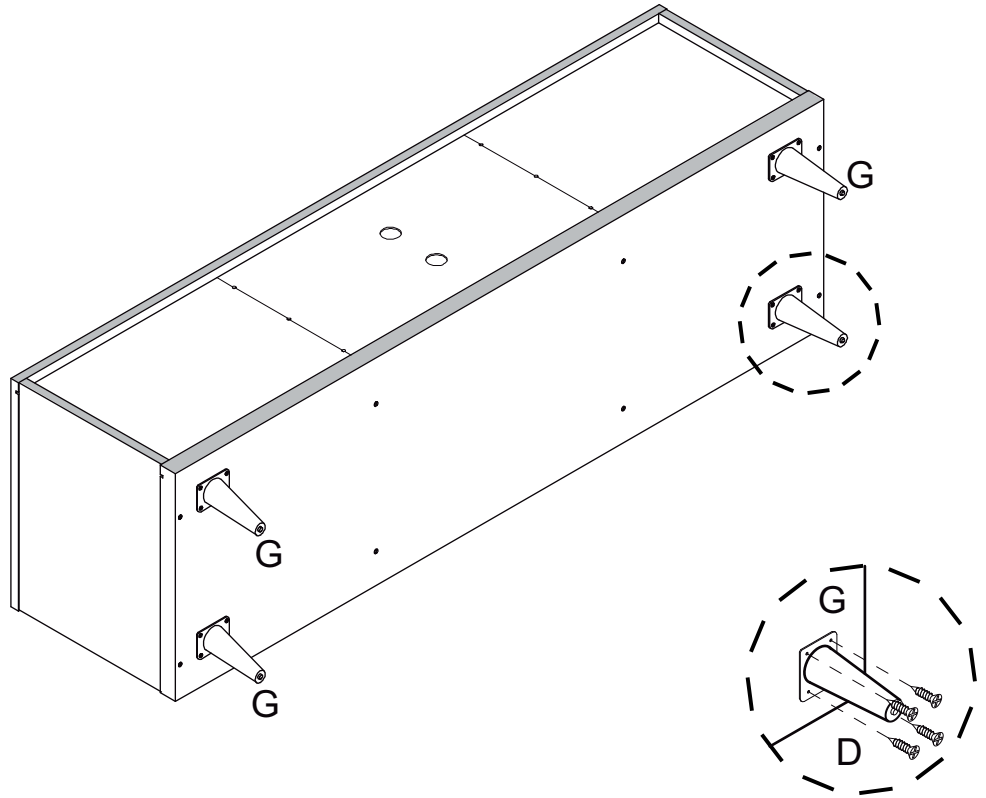
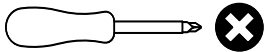

STEP 10

PARTS REQUIRED

7 - LEFT DRAWER SIDE	x2
8 - RIGHT DRAWER SIDE	x2
11 - TOP DRAWER FRONT	x1
12 - BOTTOM DRAWER FRONT	x1

HARDWARE REQUIRED

A		04
E		04
F		04

TOOLS REQUIRED

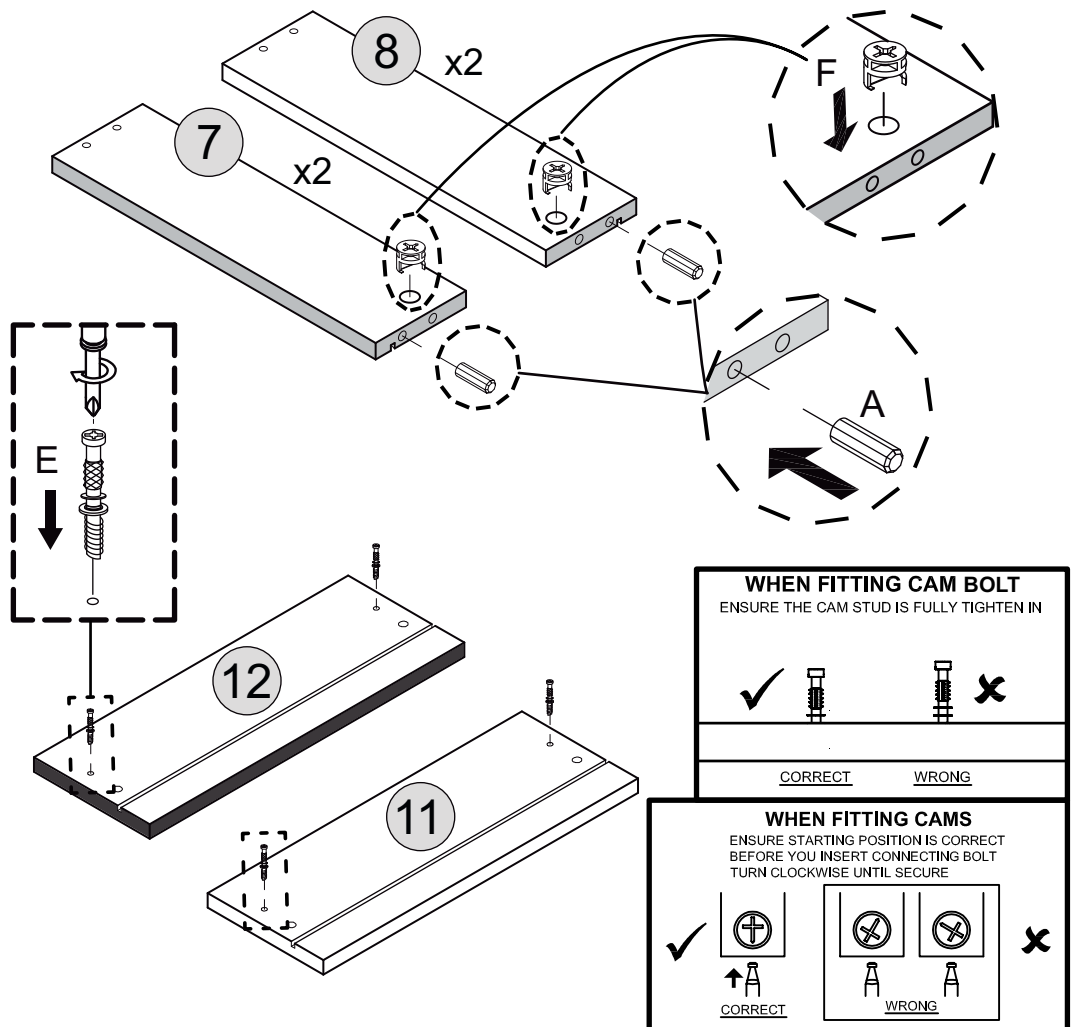
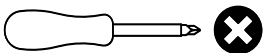

WHEN FITTING CAM BOLT
ENSURE THE CAM STUD IS FULLY TIGHTEN IN

CORRECT		WRONG	

WHEN FITTING CAMS
ENSURE STARTING POSITION IS CORRECT BEFORE YOU INSERT CONNECTING BOLT TURN CLOCKWISE UNTIL SECURE

CORRECT		WRONG		

STEP 11

PARTS REQUIRED

- 7 - LEFT DRAWER SIDE x1
- 8 - RIGHT DRAWER SIDE x1
- 9 - DRAWER BACK x1
- 12 - BOTTOM DRAWER FRONT x1
- 15 - DRAWER BASE x1

HARDWARE REQUIRED

- C  04

TOOLS REQUIRED

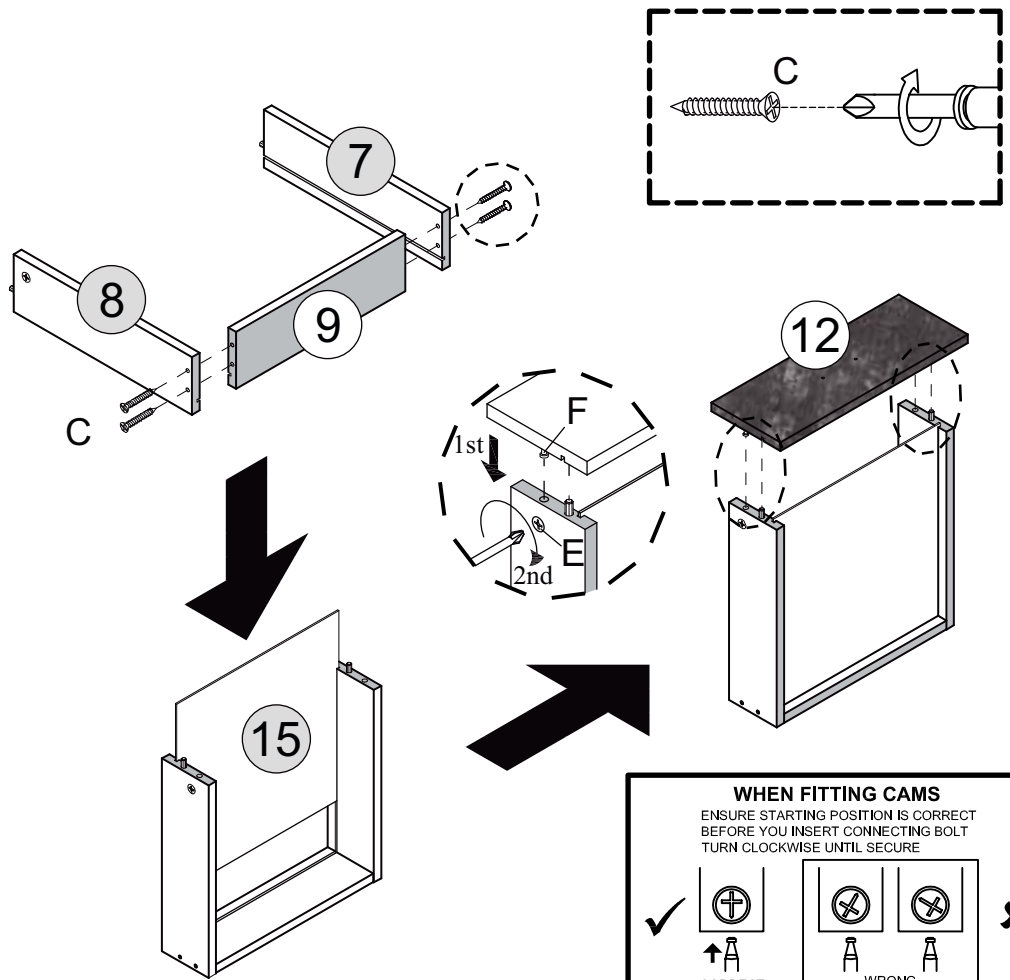
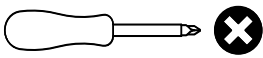

STEP 12

PARTS REQUIRED

- 7 - LEFT DRAWER SIDE x1
- 8 - RIGHT DRAWER SIDE x1
- 9 - DRAWER BACK x1
- 11 - TOP DRAWER FRONT x1
- 15 - DRAWER BASE x1

HARDWARE REQUIRED

- C  04

TOOLS REQUIRED

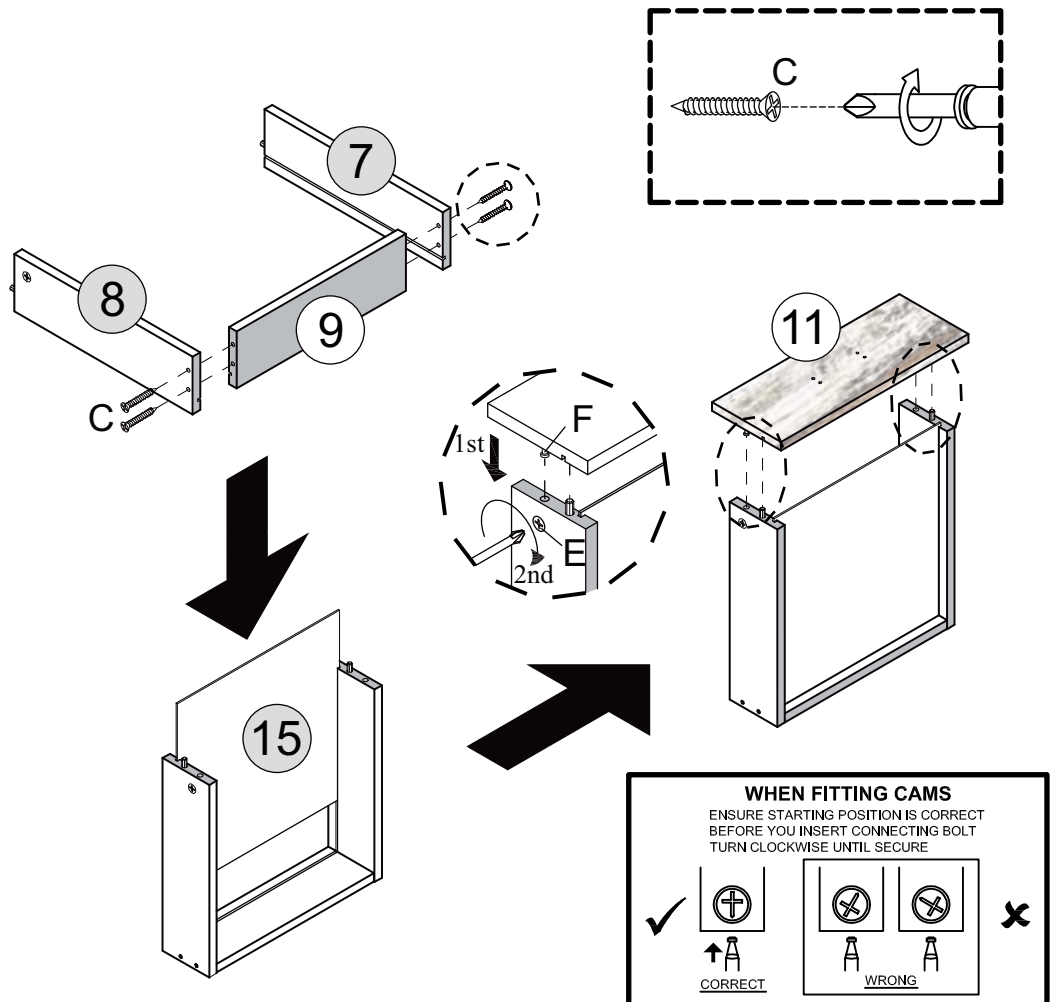
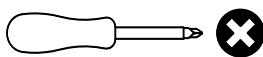

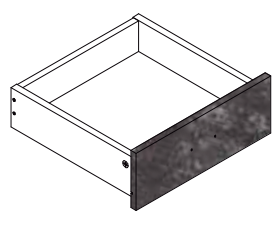

STEP 13

PARTS REQUIRED



HARDWARE REQUIRED

- D  04
- I  01
- K  01

TOOLS REQUIRED

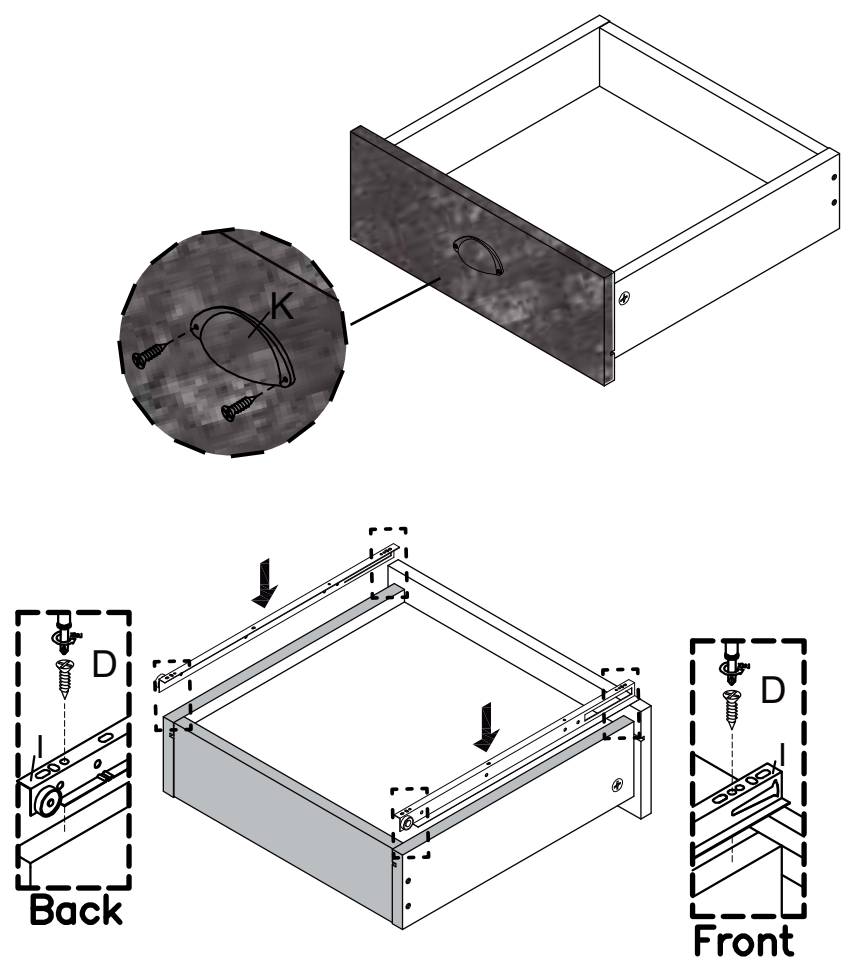
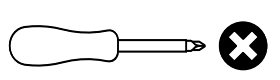

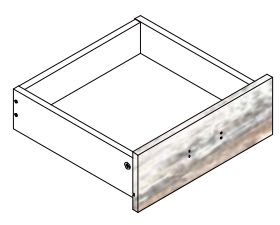

STEP 14

PARTS REQUIRED



HARDWARE REQUIRED

- D  04
- I  01
- J  01

TOOLS REQUIRED

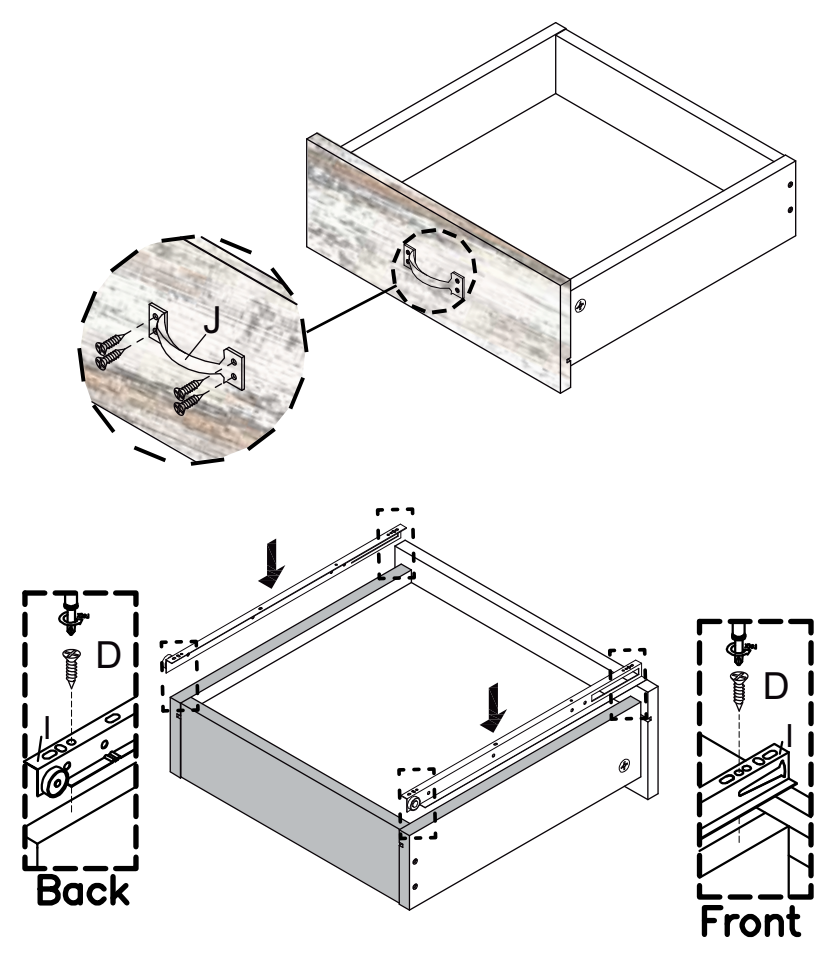
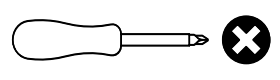

STEP 15

PARTS REQUIRED

10 - DOOR x1

HARDWARE REQUIRED

D  04

H  02

L  01

TOOLS REQUIRED

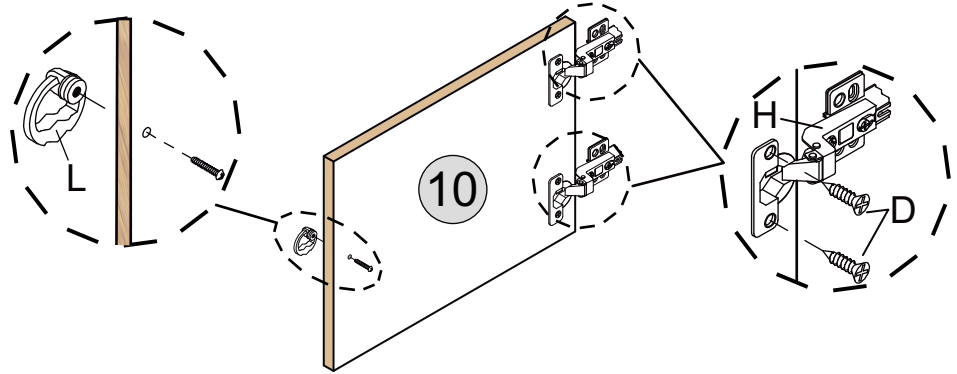
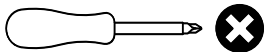

STEP 16

PARTS REQUIRED

10 - DOOR x1

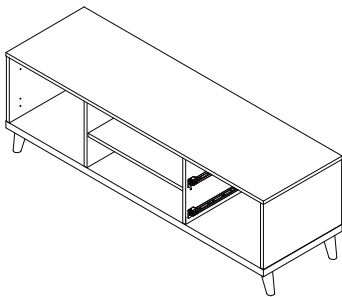

HARDWARE REQUIRED

D  04

TOOLS REQUIRED

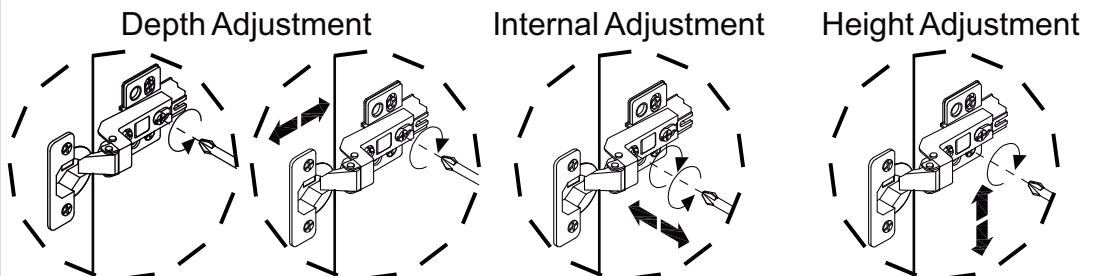
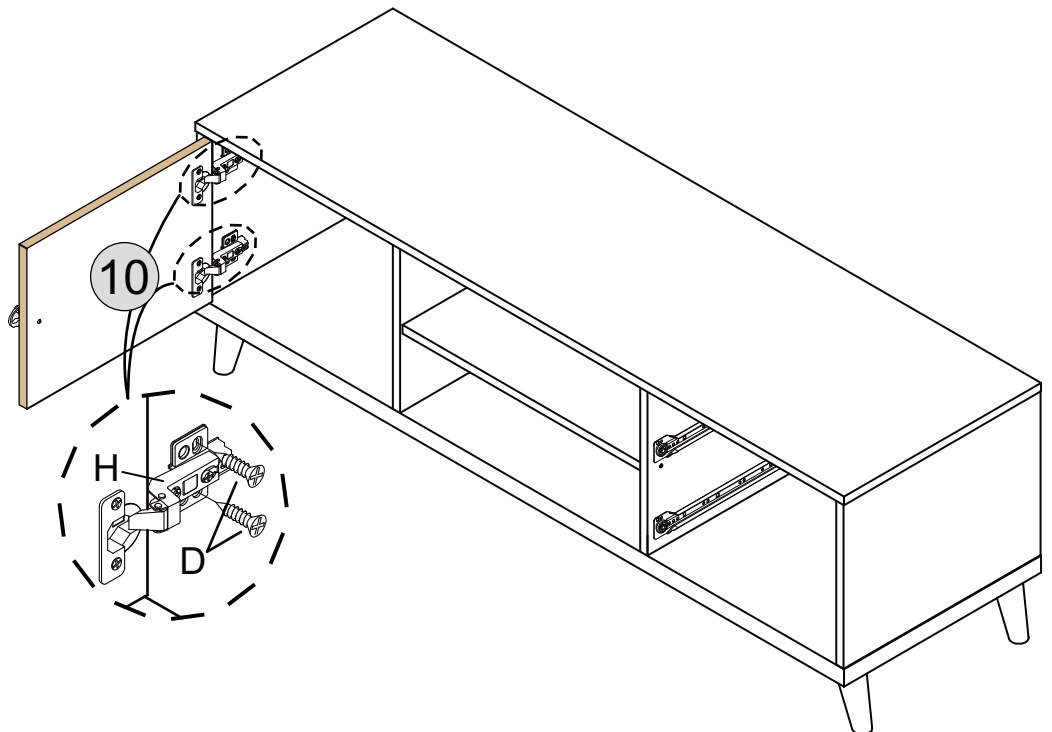
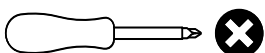

STEP 17

PARTS REQUIRED

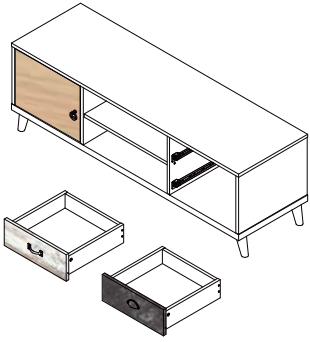

HARDWARE REQUIRED

TOOLS REQUIRED

