

MADRID WINE RACK

ASSEMBLY INSTRUCTIONS

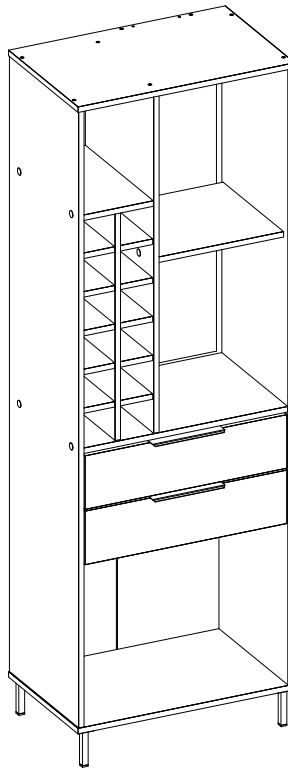

IMPORTANT

FOR DOMESTIC USE ONLY

PLEASE READ BEFORE YOU CONTINUE FURTHER

CARE AND MAINTENANCE

After unpacking this product please keep the original packaging in case it needs to be returned for any reason.

- Please ensure all fittings and parts are present before commencing with assembly.
- Never drag or push products as this could cause damage to the joints making it inferior.
- We strongly recommend that you keep children away from your work area.
- We recommend that you lay a blanket or sheet on the floor to avoid damage to both your floor and the product.
- Assemble this product as close to its final position as possible.
- Do not place this product next to a radiator or in direct sunlight.
- Do not drag or push items across your high gloss furniture as this may cause the surface to scratch
- Wood is a natural product and may expand if subjected to damp and may shrink or crack if subjected to heat. Therefore it is recommended that room temperature is maintained, with no sudden temperature fluctuations.
- Make sure any spillage is wiped off immediately.
- Do not place hot or chilled items directly on to the surface, use a place mat or marking will occur.
- For general cleaning use a soft cotton or micro fibre cloth, and do not use detergents of any kind.
- From time to time it may be necessary to tighten fittings, regular inspections should be carried out.
- Do not place on a wet or damp floor as staining may occur to your floor.

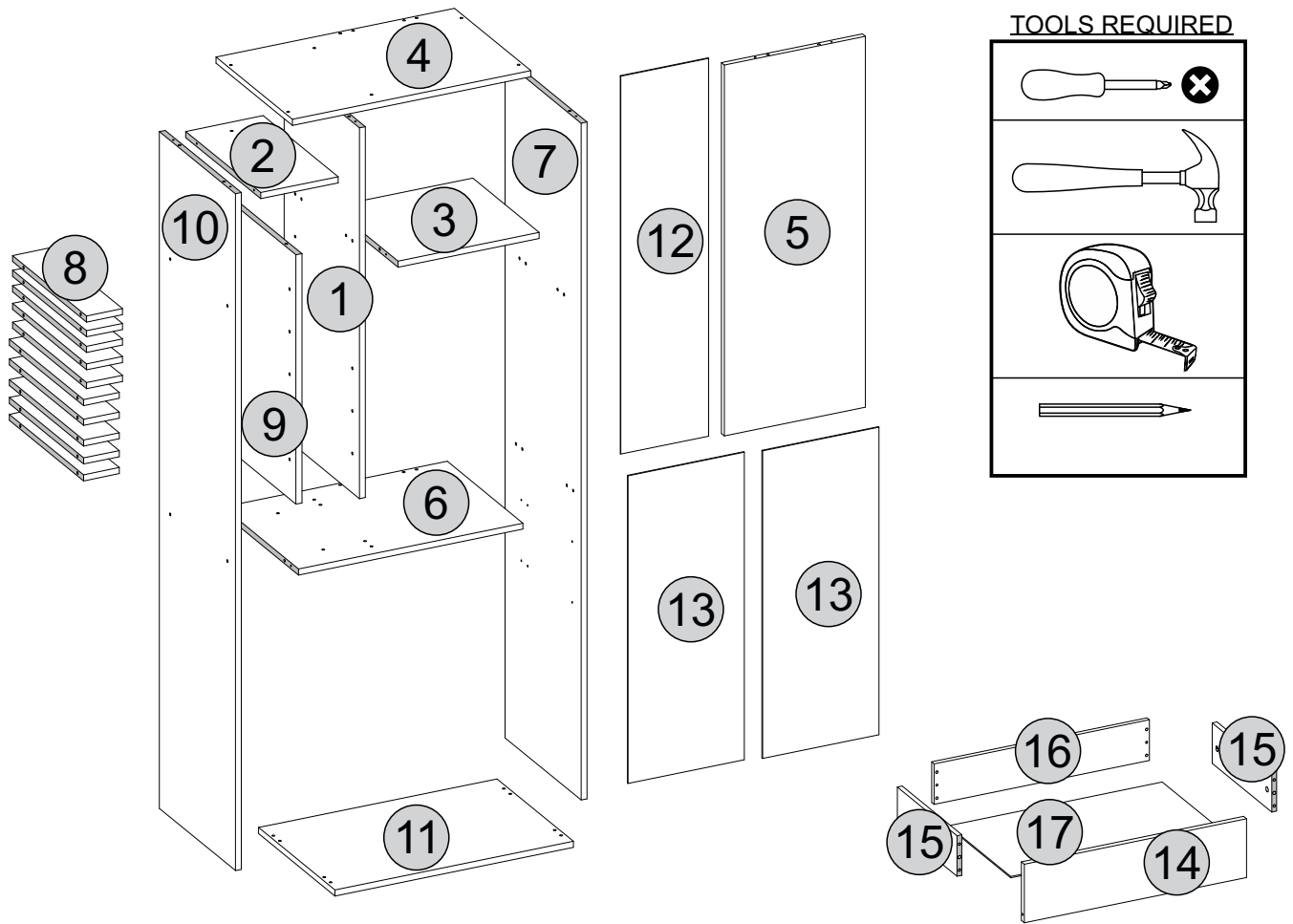

PARTS LIST









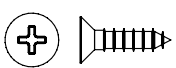
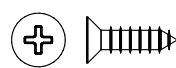

Please Note:

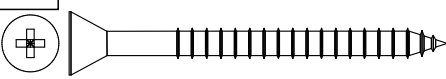
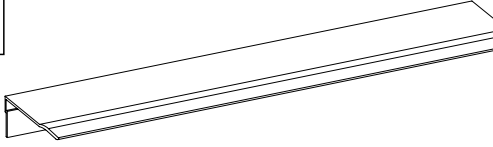
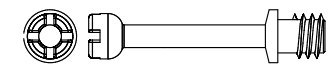
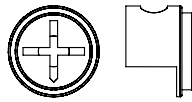
The below parts have all been stamped with the part number to help identify them during assembly.

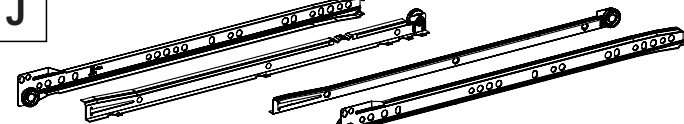
Part Number	Part Code	Part Description	Quantity	Carton
1	S300-320-030-AL1-01	Division Panel	1	2/2
2	S300-320-030-AL1-02	Left Top Shelf	1	2/2
3	S300-320-030-AL1-03	Right Top Shelf	1	2/2
4	S300-320-030-AL1-04	Top Panel	1	2/2
5	S300-320-030-AL1-05	Mirror Panel	1	1/2
6	S300-320-030-AL1-06	Drawer Top Panel	1	1/2
7	S300-320-030-AL1-07	Right Side Panel	1	1/2
8	S300-320-030-AL1-08	Cellar Shelf	10	1/2-2/2
9	S300-320-030-AL1-09	Cellar Division Panel	1	1/2
10	S300-320-030-AL1-10	Left Side Panel	1	1/2
11	S300-320-030-AL1-11	Base Panel	1	2/2
12	S300-320-030-AL1-12	Top Back Panel	1	1/2
13	S300-320-030-AL1-13	Bottom Back Panel	2	2/2
14	S300-320-030-AL1-14	Drawer Front	2	2/2
15	S300-320-030-AL1-15	Drawer Side	4	2/2
16	S300-320-030-AL1-16	Drawer Back Panel	2	2/2
17	S300-320-030-AL1-17	Drawer Bottom	2	2/2

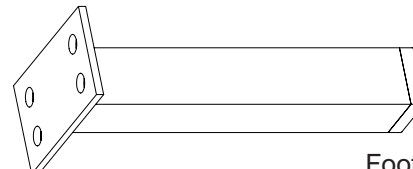
FITTINGS LIST

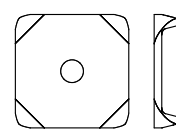
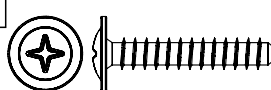
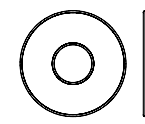
SEC/SW/10/21/AL1

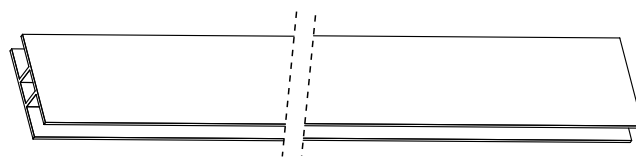
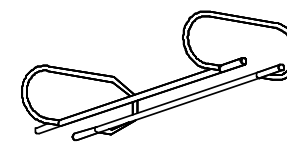
<p>A</p>  <p>+/2 Flat Head Screw Ø3,0 x 12mm (20x)</p>	<p>B</p>  <p>+/1 Flat Head Screw Ø3,5 x 12mm (6x)</p>	<p>C</p>  <p>+/2 Flat Head Screw Ø4,5 x 16mm (16x)</p>	<p>D</p>  <p>+/2 Dowel Ø6,0 x 30mm (84x)</p>
<p>E</p>  <p>+/2 Flat Head Screw Ø4,0 x 50mm (28x)</p>	<p>F</p>  <p style="text-align: center;">Handle (2x)</p>		<p>G</p>  <p>+/1 Cam Bolt (8x)</p>
<p>H</p>  <p>+/1 Cam Nut (8x)</p>	<p>I</p>  <p>+/2 Hole Plugs (30x)</p>	<p>J</p>  <p style="text-align: center;">Drawer Runners 300mm (2x)</p>	
<p>K</p>  <p>+/2 Nail 10 x 10 (48x)</p>	<p>L</p>  <p style="text-align: center;">Foot (4x)</p>	<p>M</p>  <p style="text-align: center;">Glue (3x)</p>	
<p>N</p>  <p>+/1 Back Panel Bracket (2x)</p>	<p>O</p>  <p>+/1 Flan Head Screw Ø3,5 x 22mm (1x)</p>	<p>P</p>  <p>+/1 Washer (2x)</p>	<p>Q</p>  <p style="text-align: center;">Strap (1x)</p>
<p>R</p>  <p style="text-align: center;">Back Panel Strip (1x)</p>		<p>S</p>  <p style="text-align: center;">Cup Holder (1x)</p>	

TIPS FOR FITTINGS CAM-LOCKS

WHEN FITTING CAM NUT, ENSURE STARTING POSITION IS CORRECT BEFORE YOU INSERT CONNECTING CAM BOLT TURN CLOCKWISE UNTIL SECURE

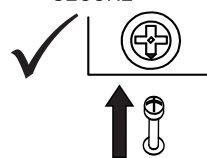

✓

CORRECT

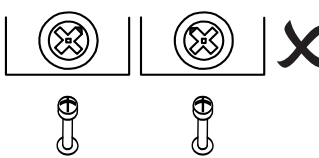

✗

WRONG

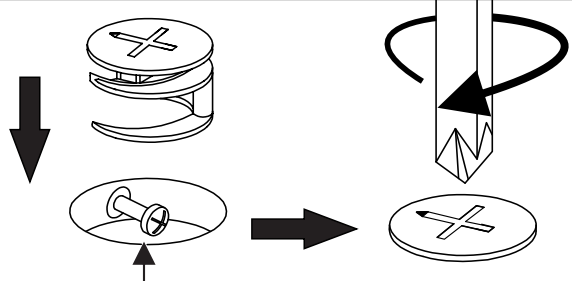

Cam bolt head needs to be in centre

CAMBOLT

Tighten until shoulder in flush with panel. Do not overtighten or undertighten (see example beside)



Shoulder

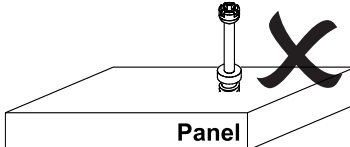

✗

Panel

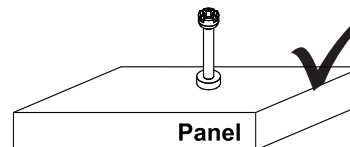

✓



Panel

STEP 1

PARTS REQUIRED

1 - DIVISION PANEL	x1
2 - LEFT TOP SHELF	x1
3 - RIGHT TOP SHELF	x1

HARDWARE REQUIRED

D		12
M		01

TOOLS REQUIRED

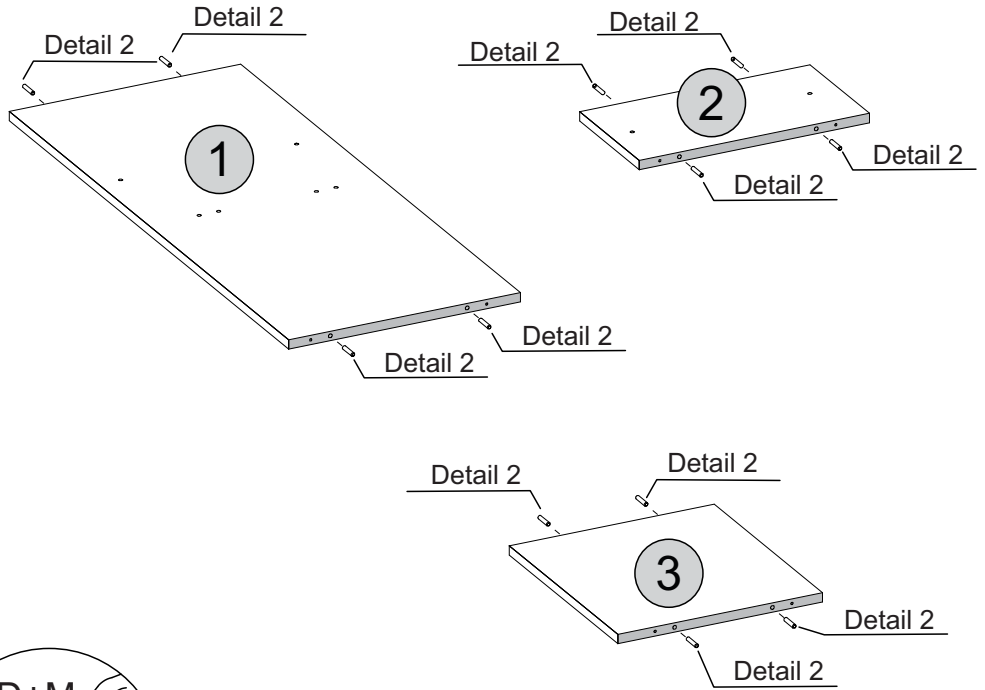
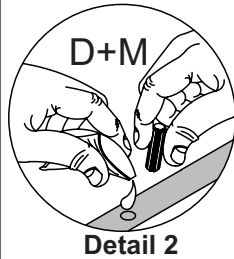
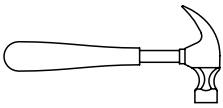



STEP 2

PARTS REQUIRED

5 - MIRROR PANEL	x1
6 - DRAWER TOP PANEL	x1
8 - CELLAR SHELF	x10

HARDWARE REQUIRED

D		48
M		01

TOOLS REQUIRED

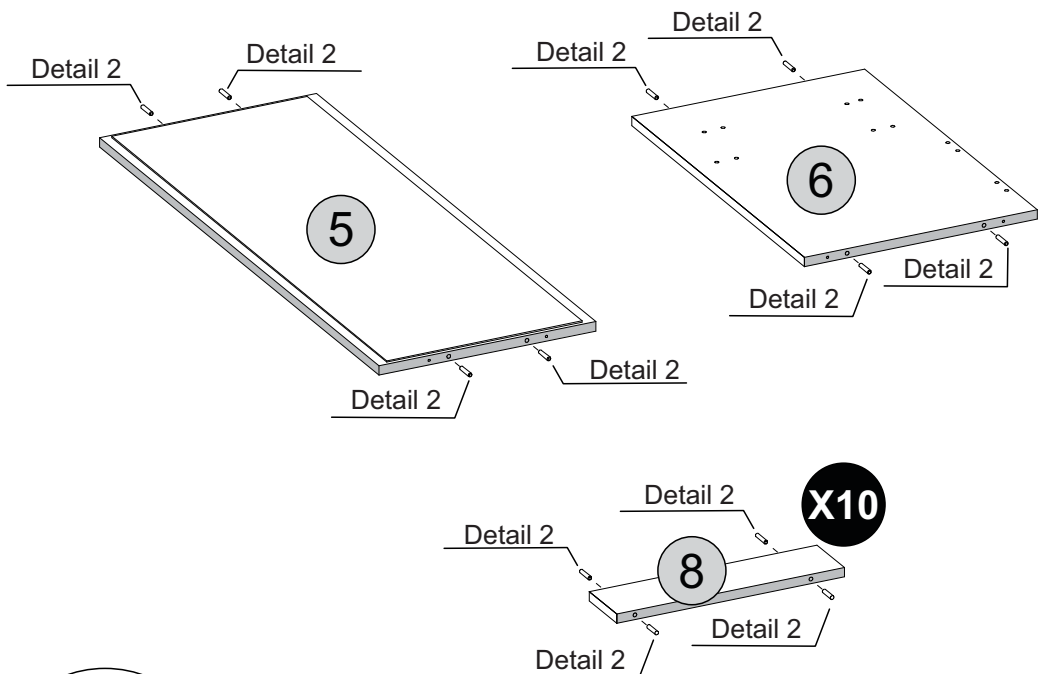
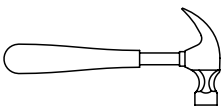

STEP 3

PARTS REQUIRED

7 - RIGHT SIDE PANEL x1

10- LEFT SIDE PANEL x1

HARDWARE REQUIRED

D  08
Ø6,0 x 30mm

M  01

TOOLS REQUIRED

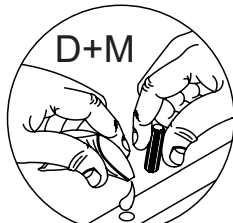
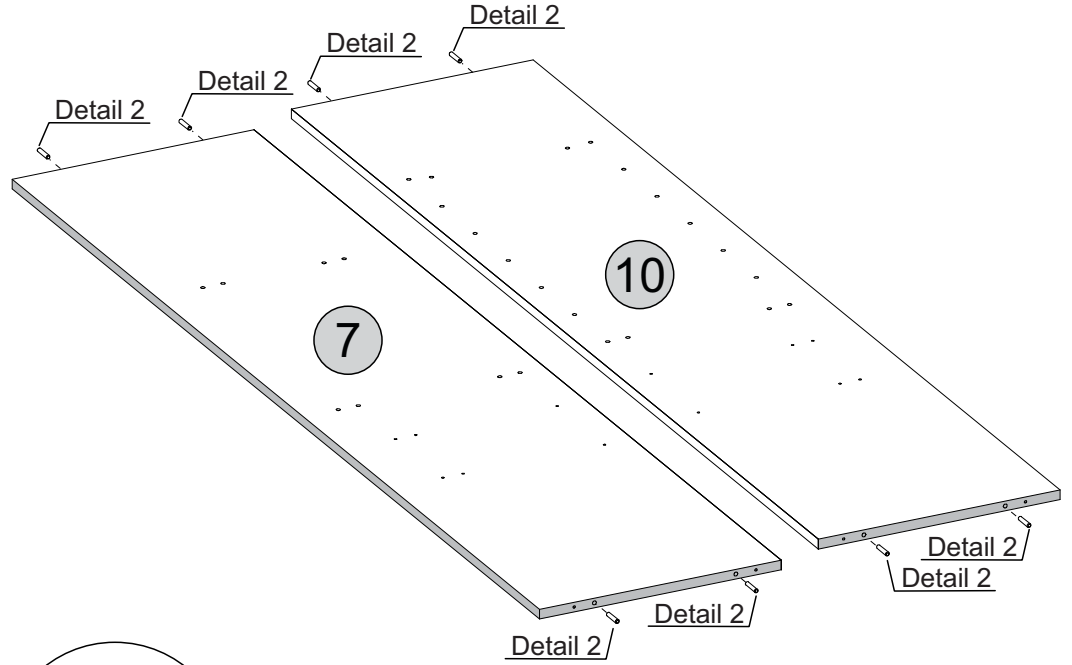
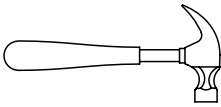

Detail 2

STEP 4

PARTS REQUIRED

7 - RIGHT SIDE PANEL x1

10 - LEFT SIDE PANEL x1

HARDWARE REQUIRED

A  08
Ø3,0 x 12mm

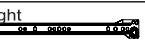
J  02
Right

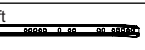
J  02
Left

TOOLS REQUIRED

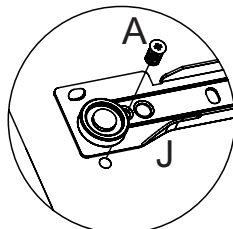
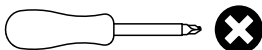

Detail 1

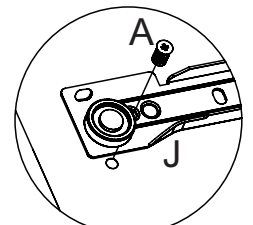
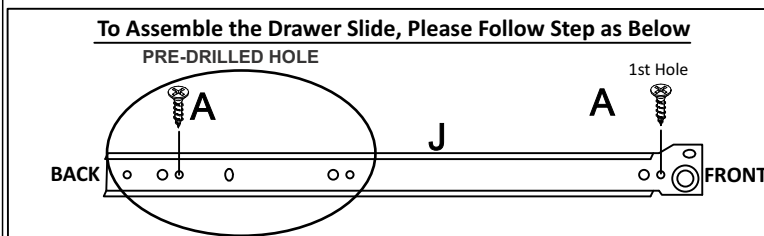
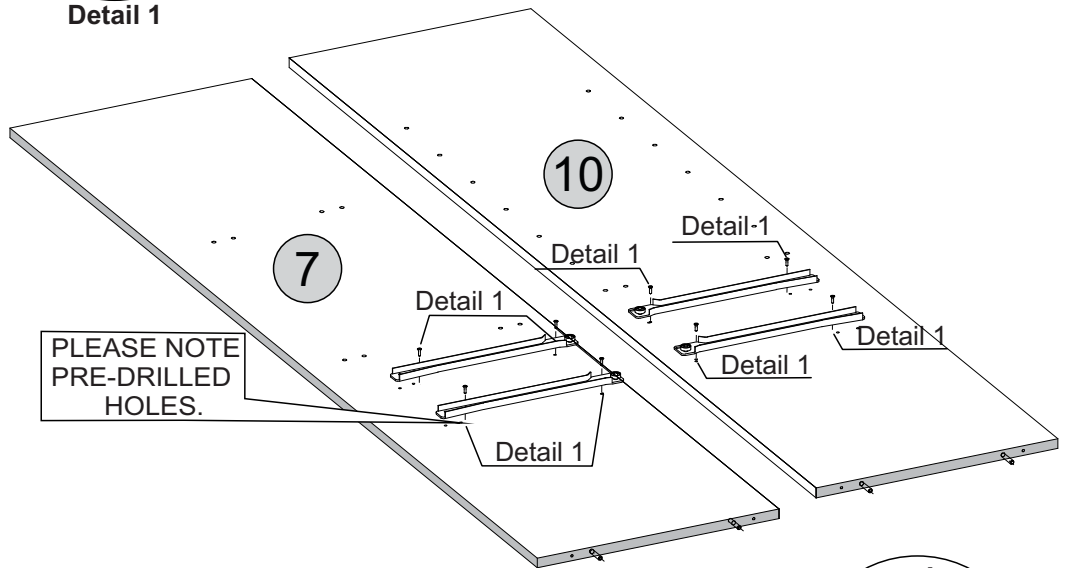
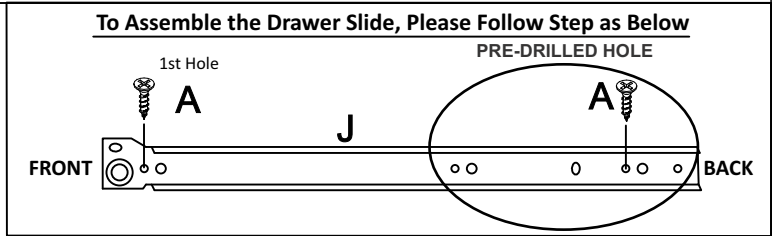



Detail 1

STEP 5

PARTS REQUIRED

- 1 - DIVISION PANEL x1
- 2 - LEFT TOP SHELF x1

HARDWARE REQUIRED

- E  02
Ø4.0 x 50mm
- M  01

TOOLS REQUIRED

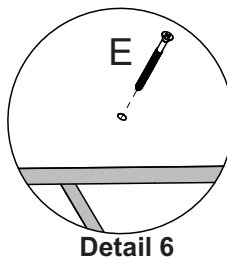
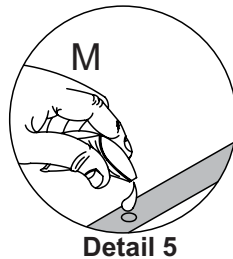
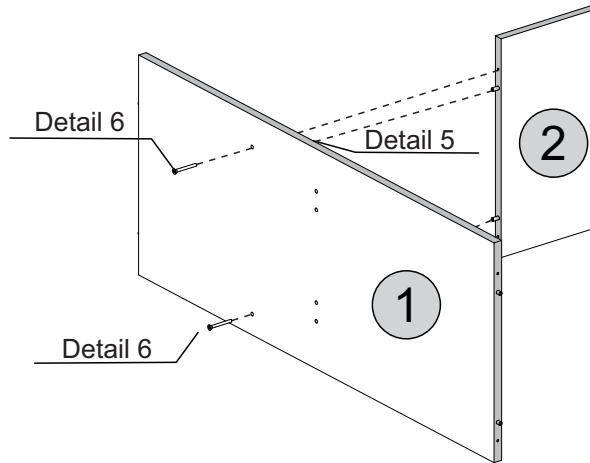
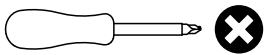



STEP 6

PARTS REQUIRED

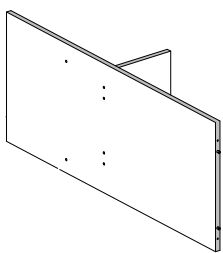
- 3 - RIGHT TOP SHELF x1



HARDWARE REQUIRED

- E  02
Ø4.0 x 50mm
- M  01

TOOLS REQUIRED

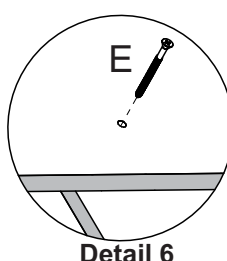
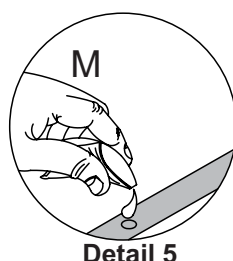
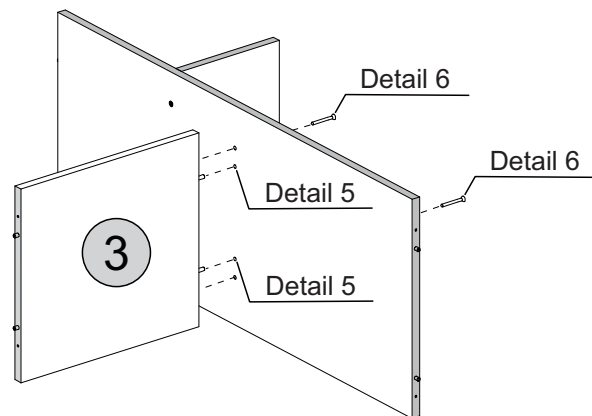
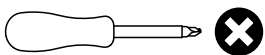

STEP 7

PARTS REQUIRED

4- TOP PANEL x1

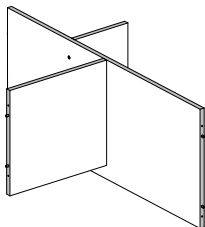

HARDWARE REQUIRED

E  02
Ø4.0 x 50mm

M  01

TOOLS REQUIRED

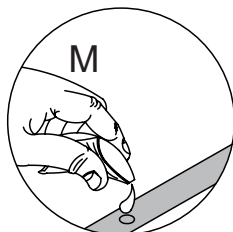
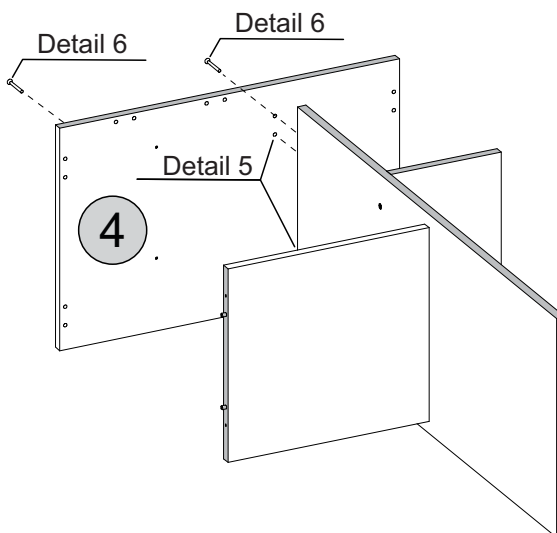
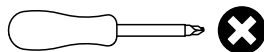

Detail 5

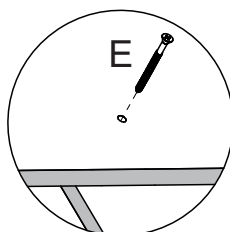

Detail 6

STEP 8

PARTS REQUIRED

5 - MIRROR PANEL x1

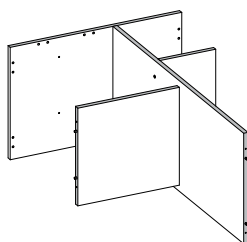

HARDWARE REQUIRED

E  02
Ø4.0 x 50mm

M  01

TOOLS REQUIRED

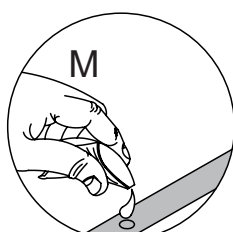
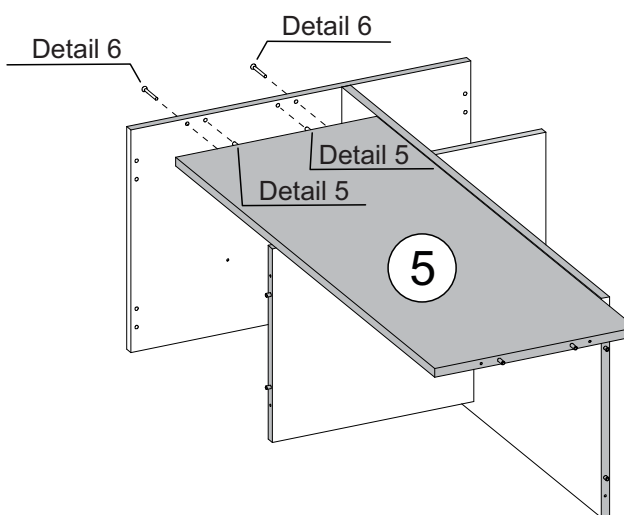
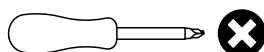

Detail 5

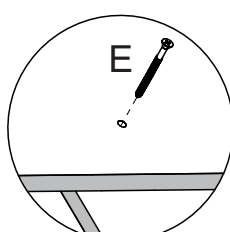

Detail 6

STEP 9

PARTS REQUIRED

6 - DRAWER TOP PANEL x1

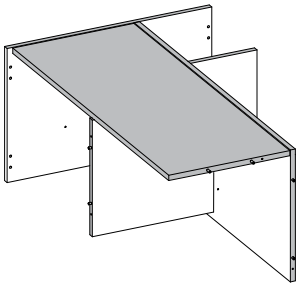

HARDWARE REQUIRED

E  04
Ø4,0 x 50mm

M  01

TOOLS REQUIRED

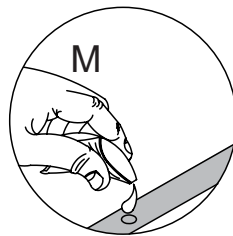
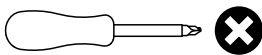

Detail 5

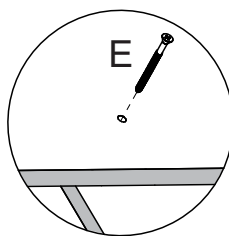

Detail 6

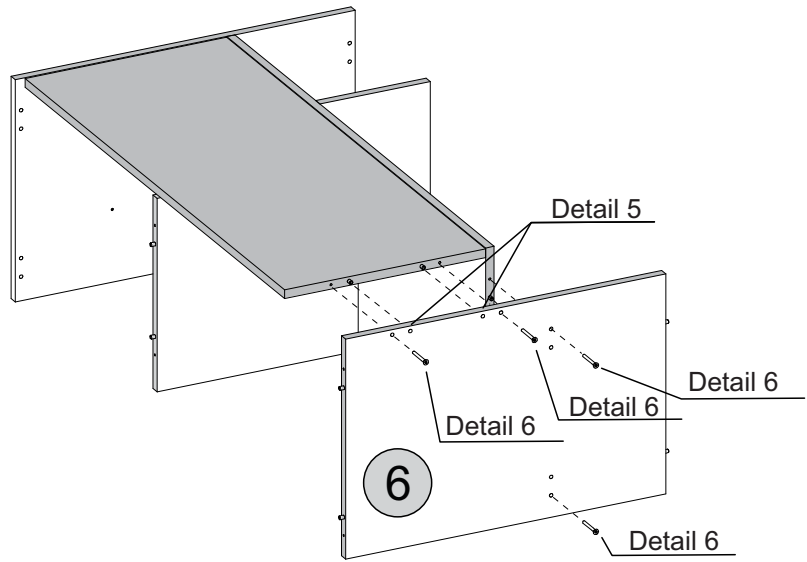

STEP 10

PARTS REQUIRED

7 - RIGHT SIDE PANEL x1

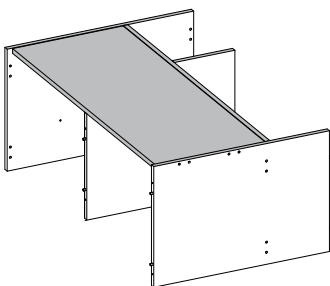

HARDWARE REQUIRED

E  06
Ø4,0 x 50mm

M  01

TOOLS REQUIRED

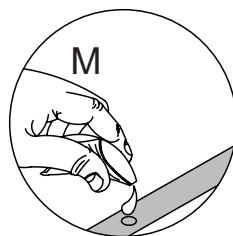
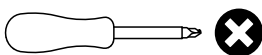

Detail 5

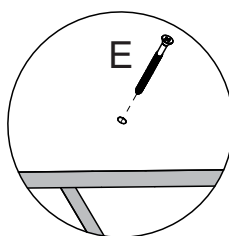

Detail 6

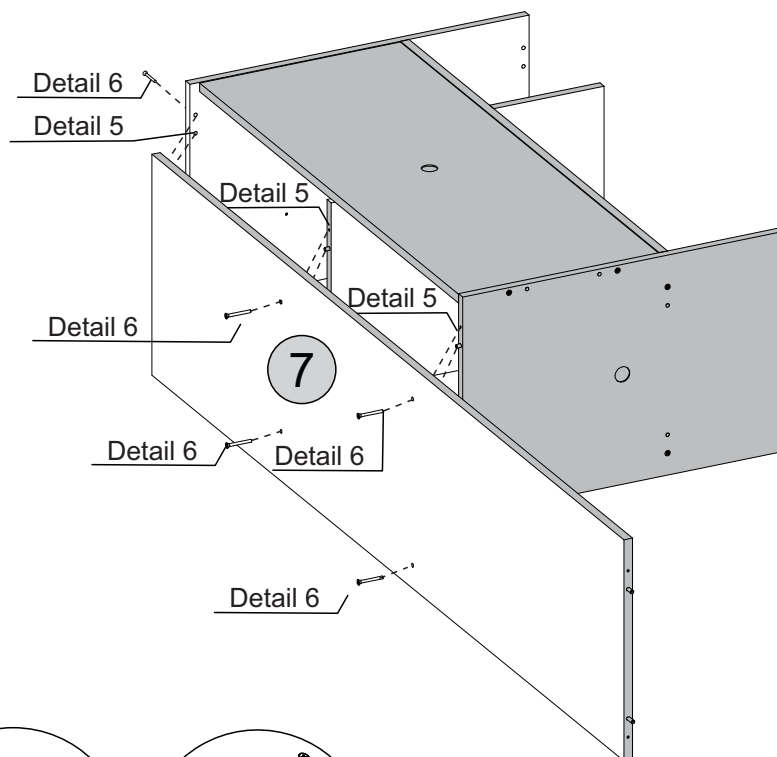

STEP 11

PARTS REQUIRED

8 - CELLAR SHELF x5

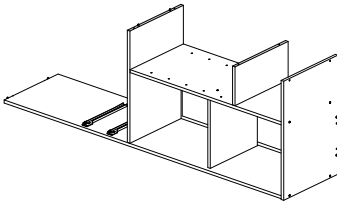

HARDWARE REQUIRED

M Glue 01

TOOLS REQUIRED

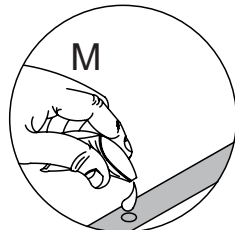
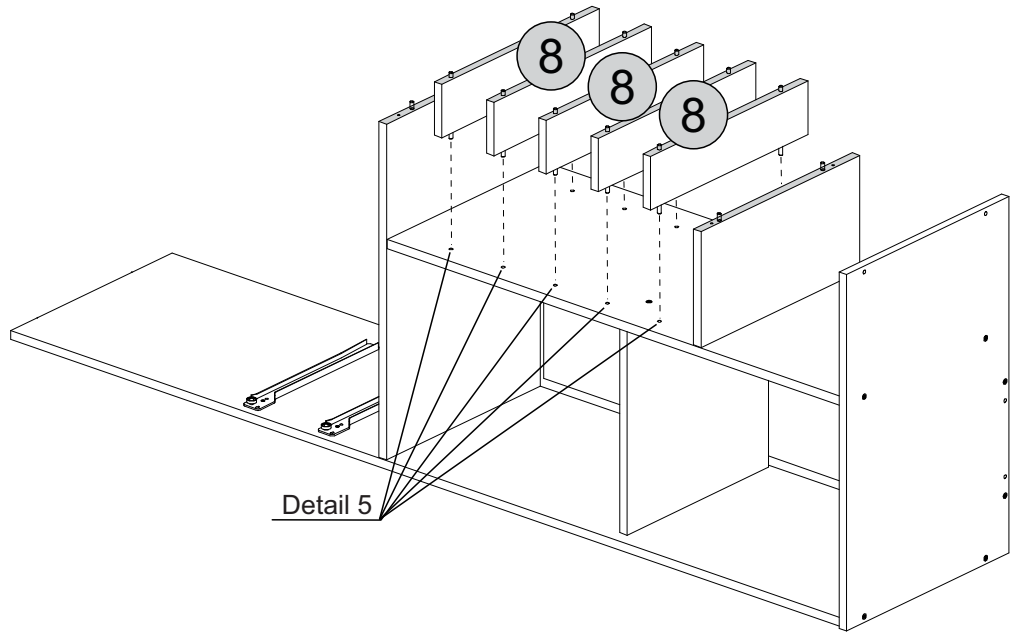

Detail 5

STEP 12

PARTS REQUIRED

9 - CELLAR DIVISION PANEL x1

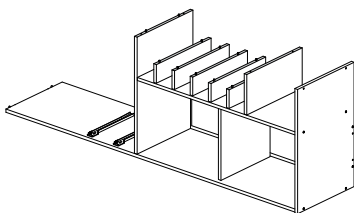

HARDWARE REQUIRED

M Glue 01

TOOLS REQUIRED

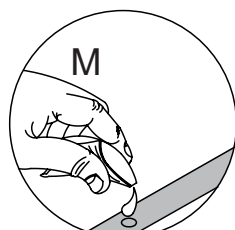
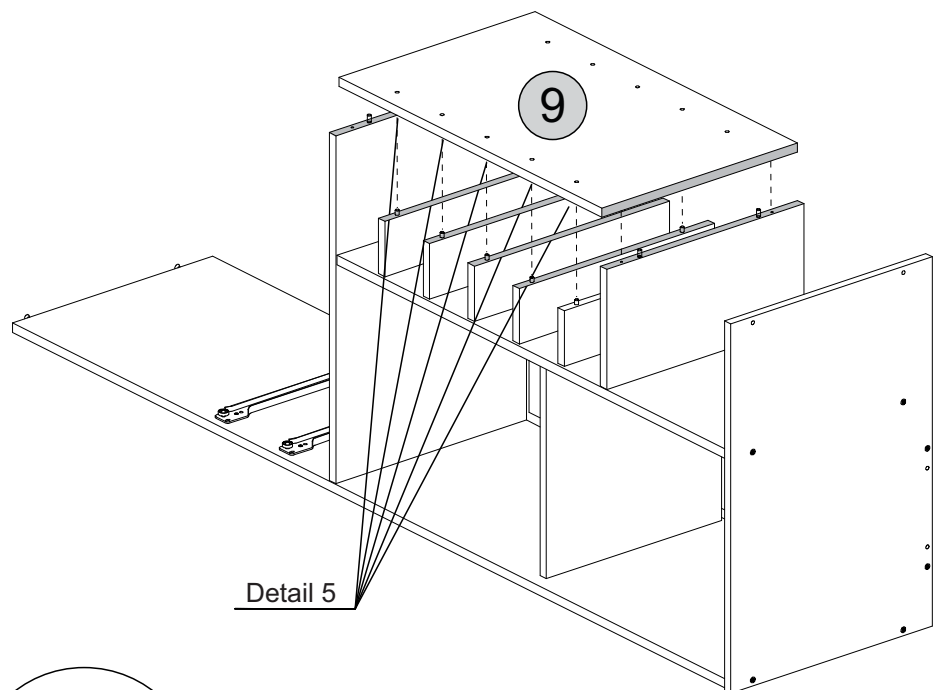

Detail 5

STEP 13

PARTS REQUIRED

8 - CELLAR SHELF x5

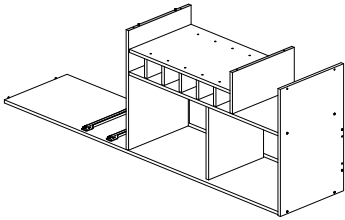

HARDWARE REQUIRED

M  01

TOOLS REQUIRED

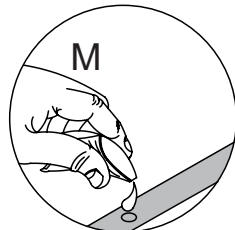
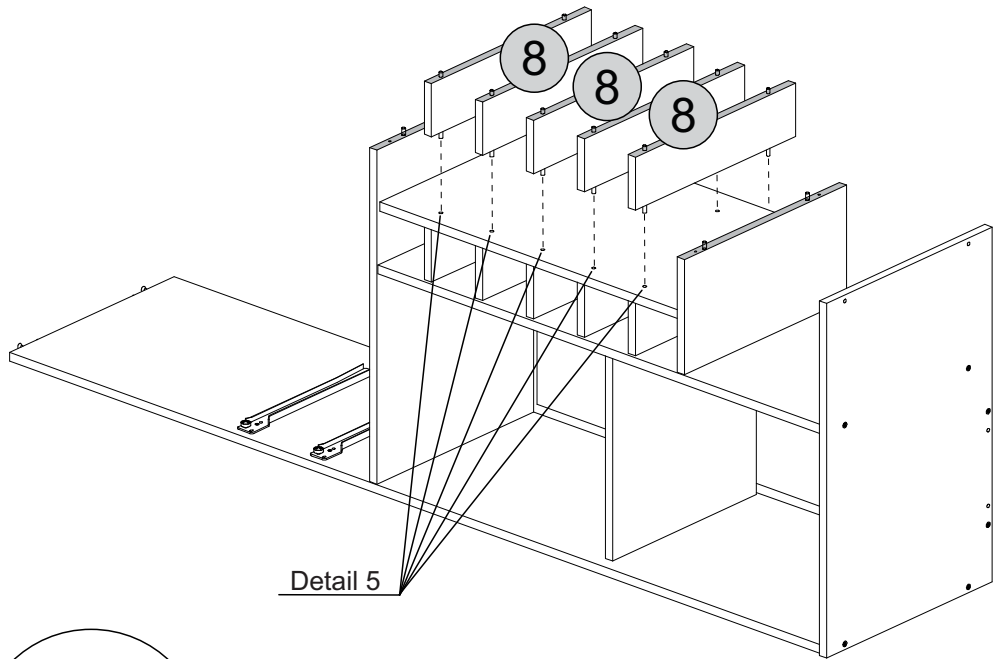

Detail 5

STEP 14

PARTS REQUIRED

10 - LEFT SIDE PANEL x1

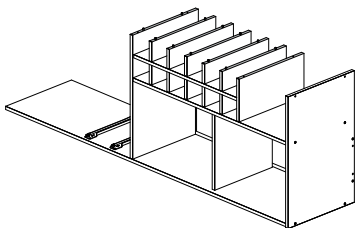

HARDWARE REQUIRED

E  06
Ø4.0 x 50mm

M  01

TOOLS REQUIRED

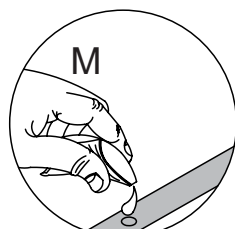
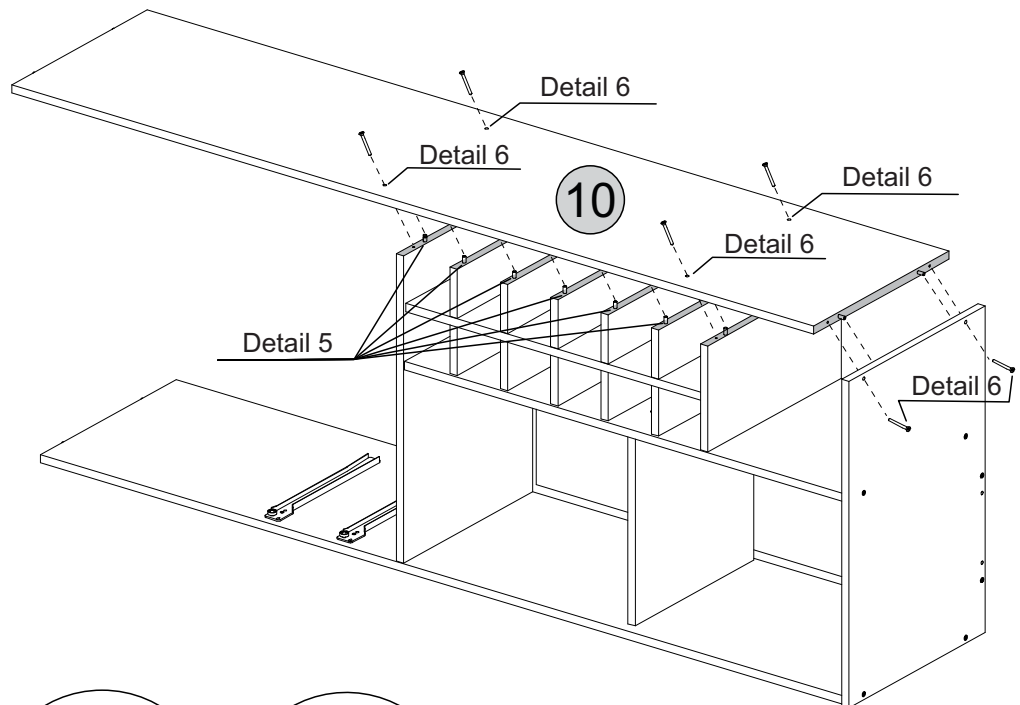
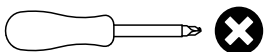

Detail 5

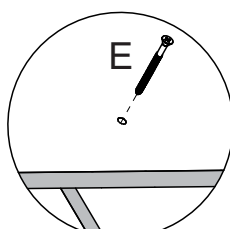

Detail 6

STEP 15

PARTS REQUIRED

11 - BASE PANEL x1

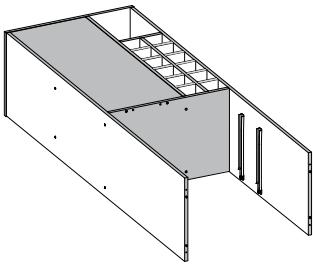

HARDWARE REQUIRED

E  04
Ø4,0 x 50mm

M  01

TOOLS REQUIRED

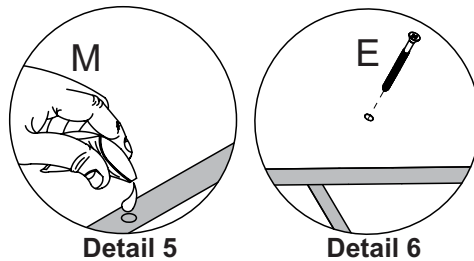

Detail 5

Detail 6

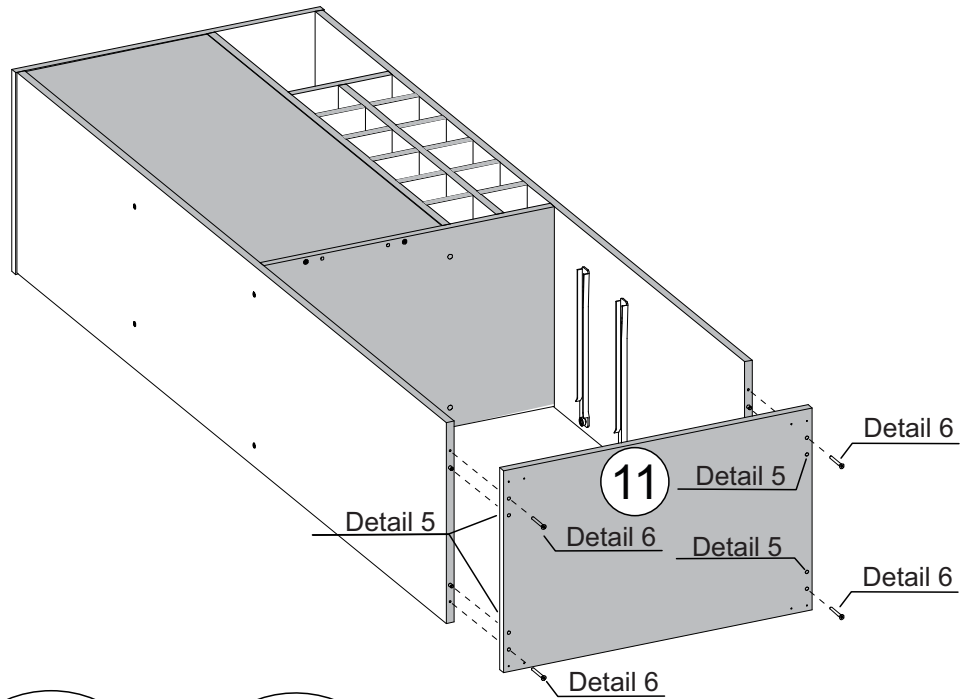

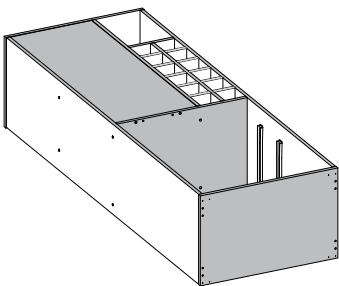

STEP 16

PARTS REQUIRED

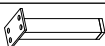

HARDWARE REQUIRED

L  04

C  16
Ø4,5 x 16mm

TOOLS REQUIRED

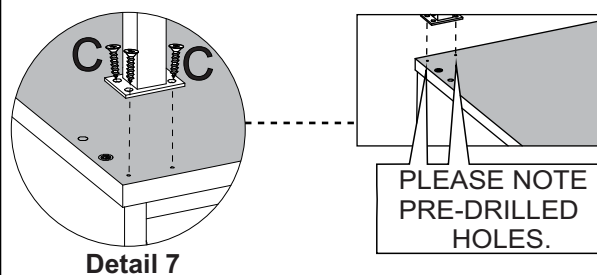
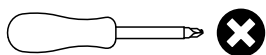

Detail 7

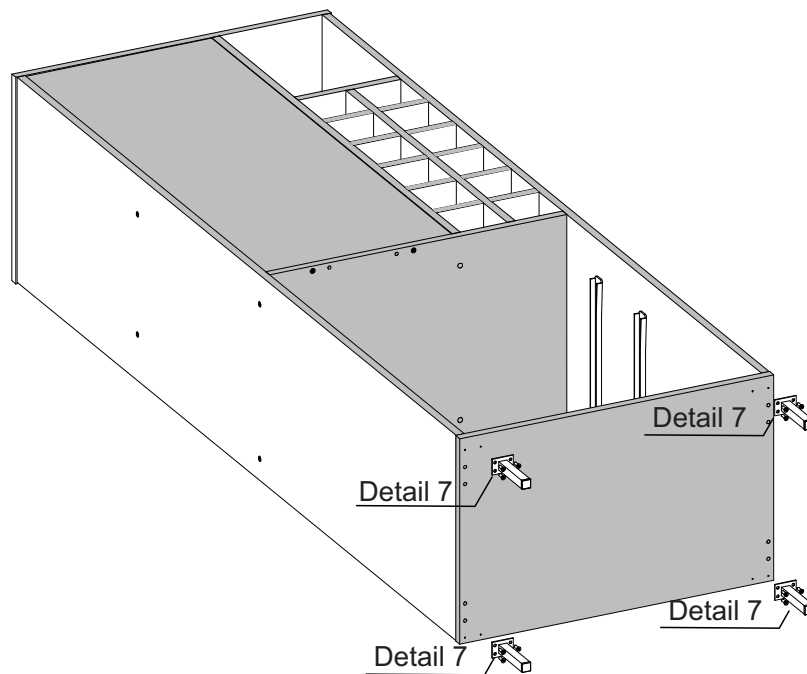



STEP 17

PARTS REQUIRED

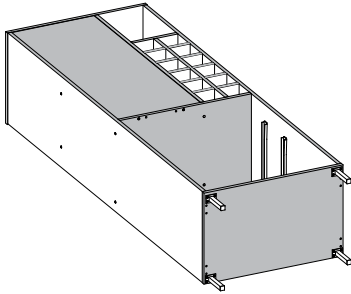
12 - TOP BACK PANEL	x1
13 - BOTTOM BACK PANEL	x2

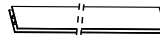

HARDWARE REQUIRED

K		32
R		01
N		02

TOOLS REQUIRED

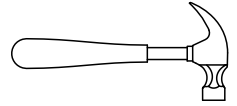

* For your future reference
Order Number should be here

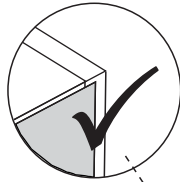

Detail 12

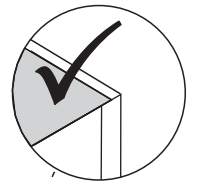
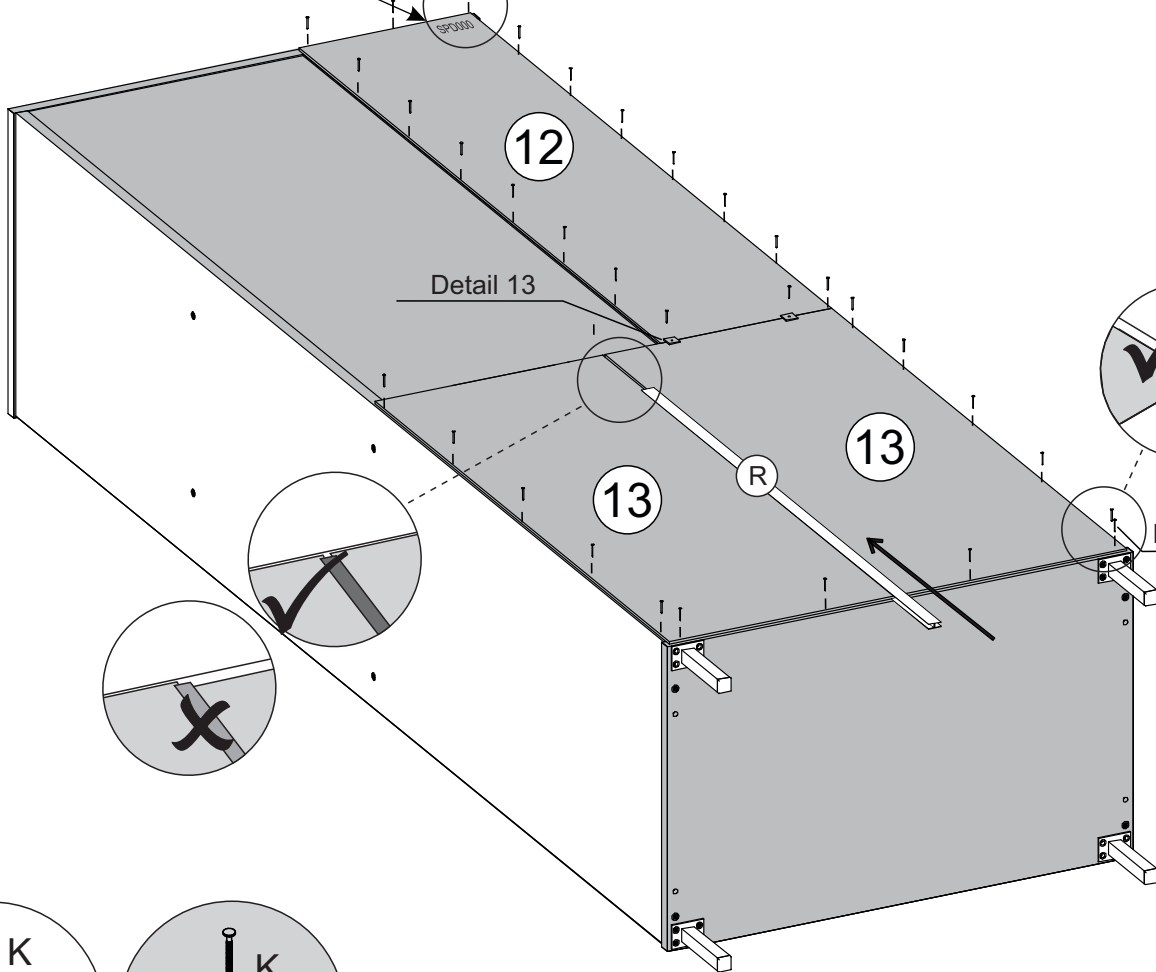
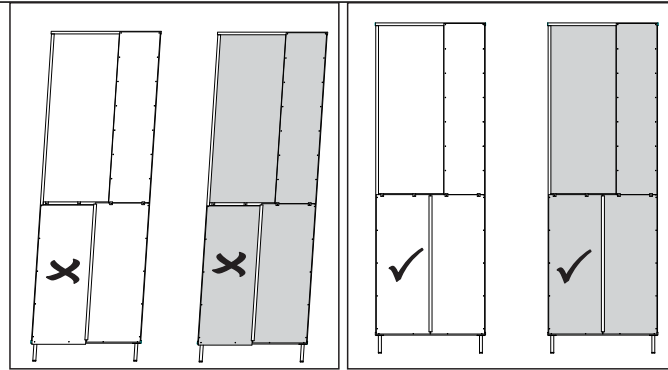

Detail 12

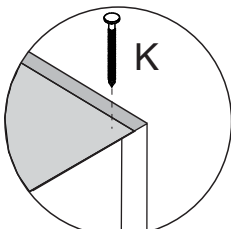
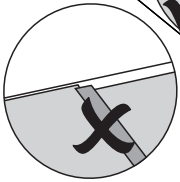
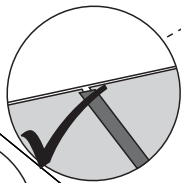

Detail 12

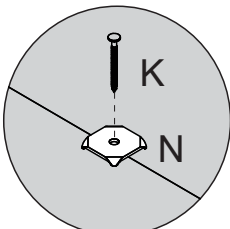

Detail 13

STEP 18

PARTS REQUIRED

15 - DRAWER SIDE x4

HARDWARE REQUIRED

D  16
Ø6.0 x 30mm

M  01

TOOLS REQUIRED

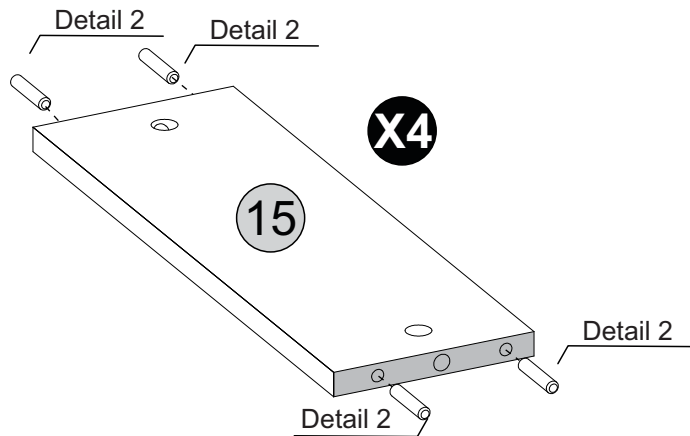

Detail 2

STEP 19

PARTS REQUIRED

16 - DRAWER BACK PANEL x2

HARDWARE REQUIRED

G  04

TOOLS REQUIRED

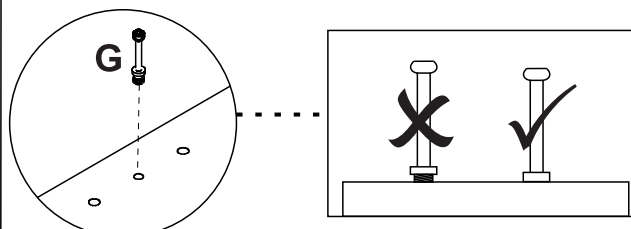
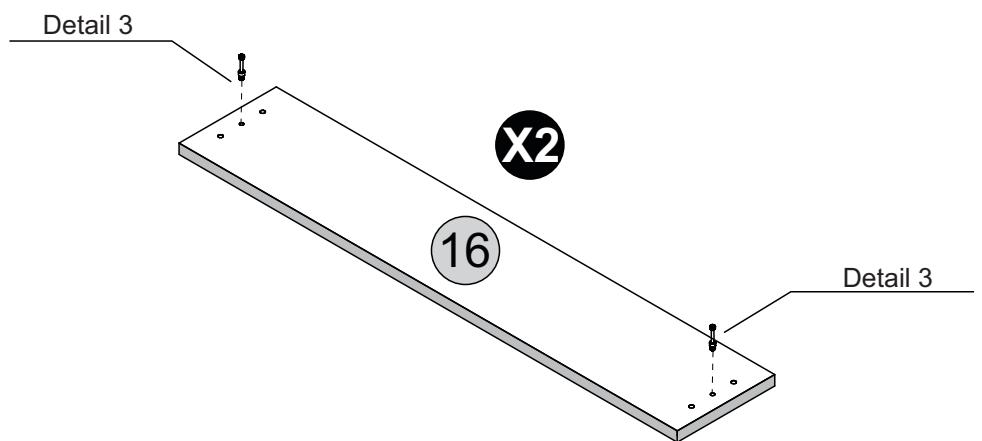
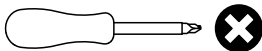

Detail 3

STEP 20

PARTS REQUIRED

14 - DRAWER FRONT x2

HARDWARE REQUIRED

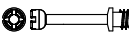
G  04

TOOLS REQUIRED

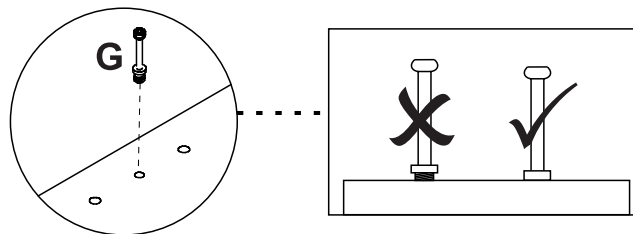
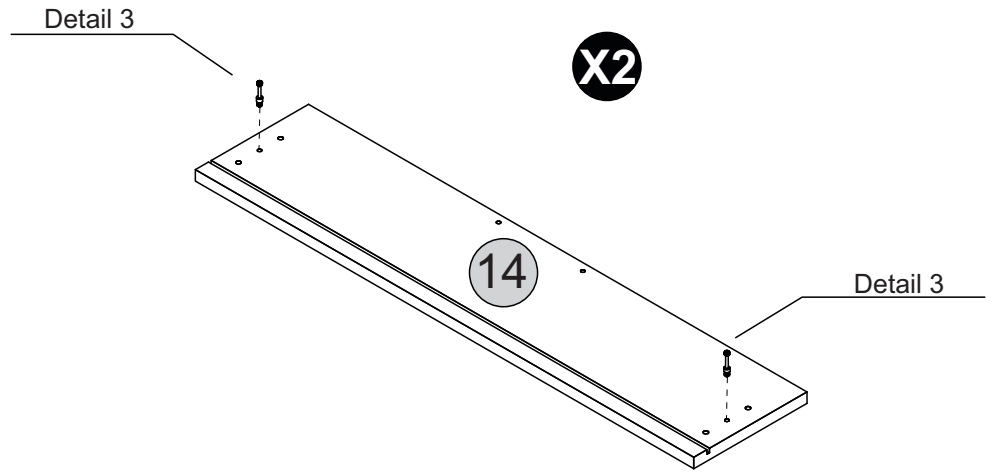
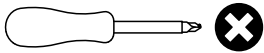

Detail 3

STEP 21

PARTS REQUIRED

15 - DRAWER SIDE x4

16 - DRAWER BACK PANEL x2

HARDWARE REQUIRED

I  04

M  01

H  04

TOOLS REQUIRED

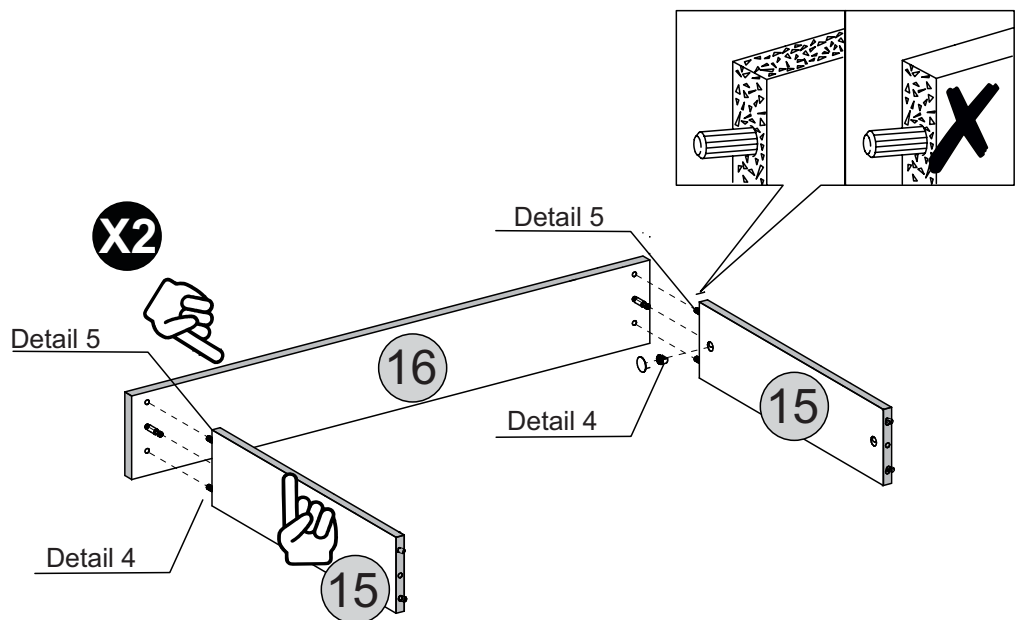
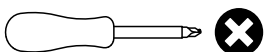

Detail 2

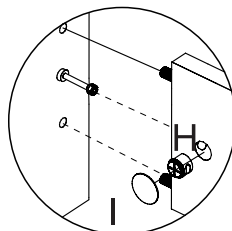

Detail 4

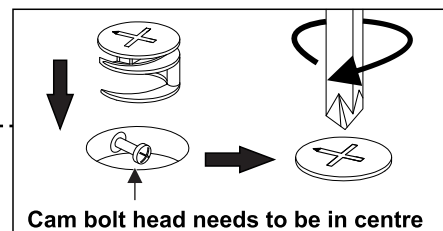

Cam bolt head needs to be in centre

STEP 22

PARTS REQUIRED

14 - DRAWER FRONT x2

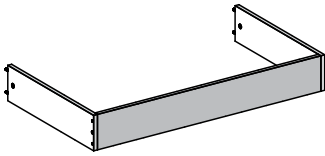

HARDWARE REQUIRED

I  04

M  01

H  04

TOOLS REQUIRED

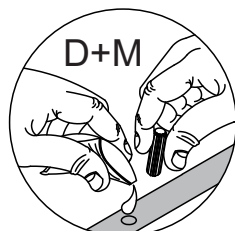
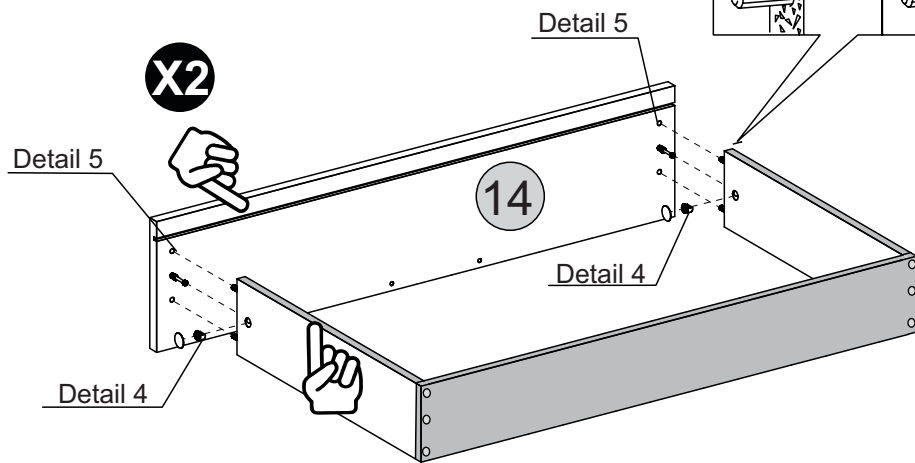
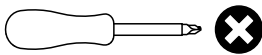

Detail 2

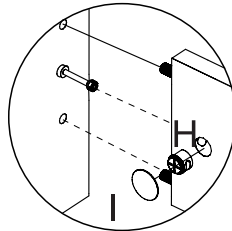

Detail 4

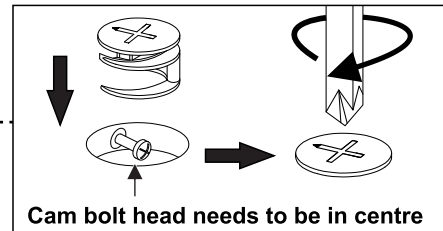

STEP 23

PARTS REQUIRED

17 - DRAWER BOTTOM x2

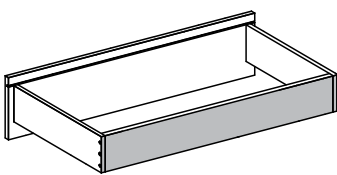

HARDWARE REQUIRED

K  14
10 x 10

TOOLS REQUIRED

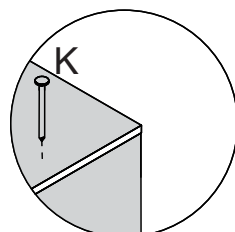
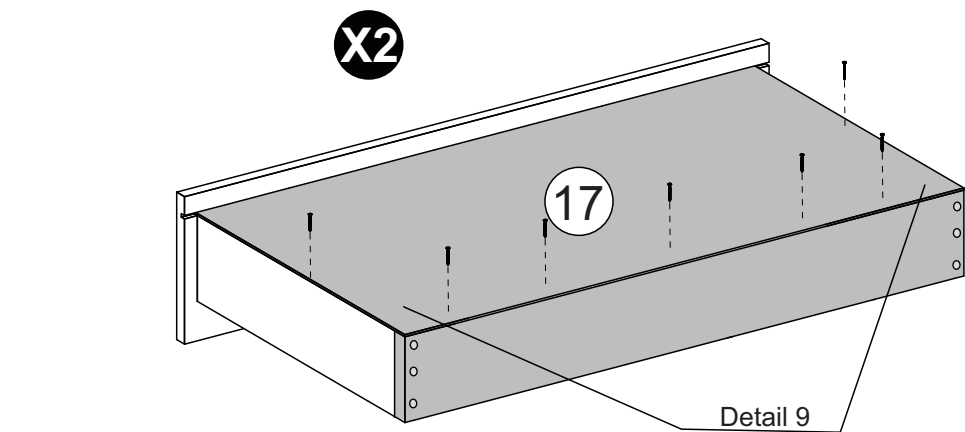
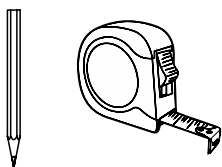
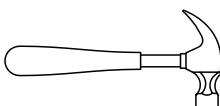

Detail 9

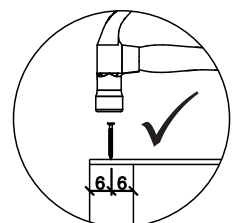
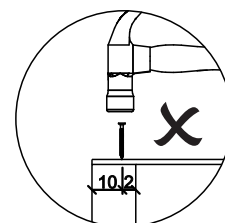
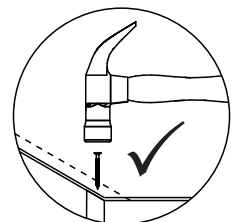
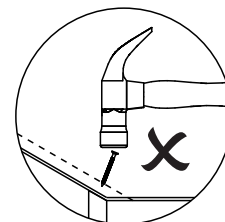

STEP 24

PARTS REQUIRED

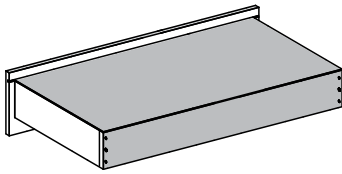

HARDWARE REQUIRED

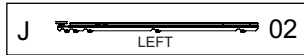
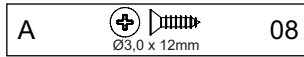

TOOLS REQUIRED

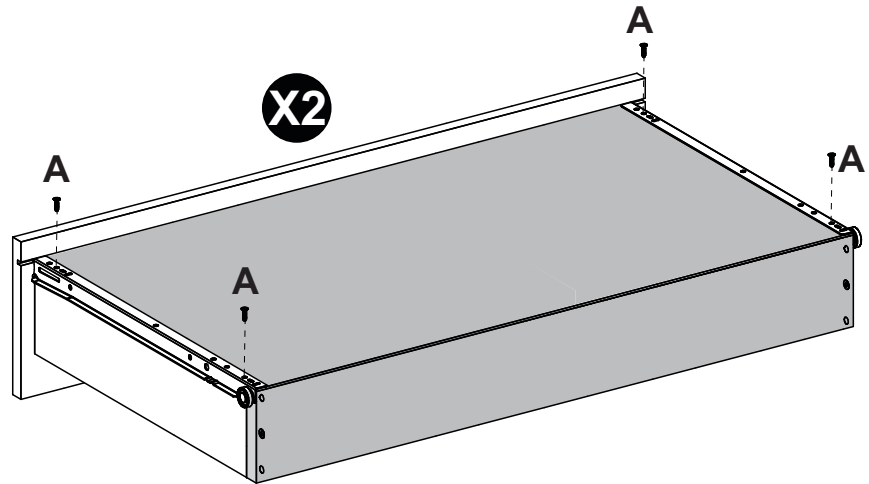
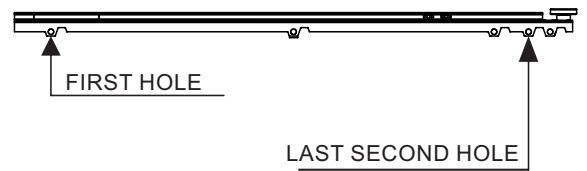
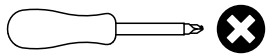

STEP 25

PARTS REQUIRED

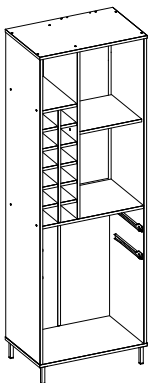

HARDWARE REQUIRED

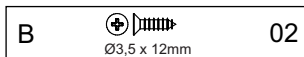
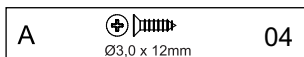

TOOLS REQUIRED

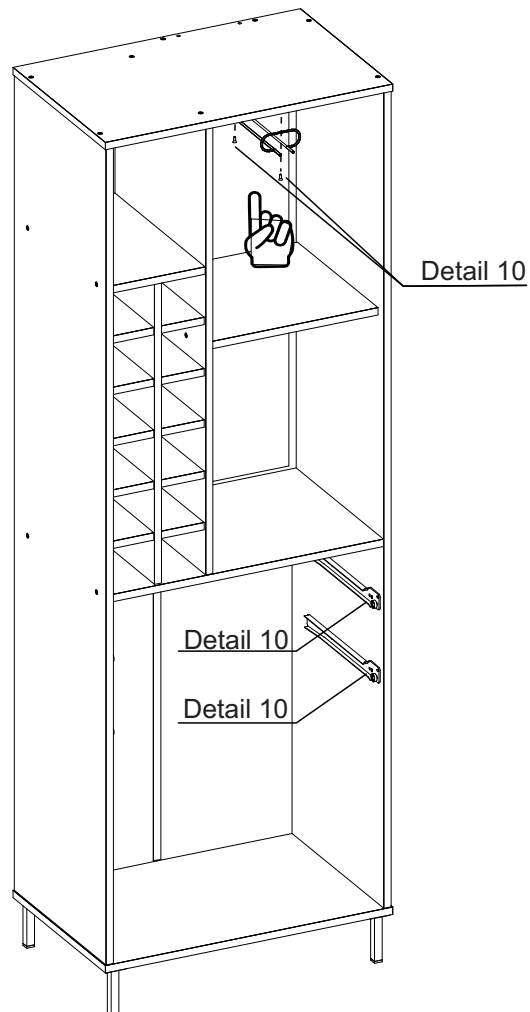
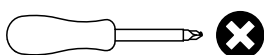

PLEASE NOTE
PRE-DRILLED
HOLES.

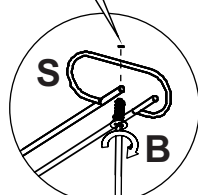

Detail 10

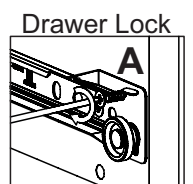

Detail 14

STEP 26

PARTS REQUIRED

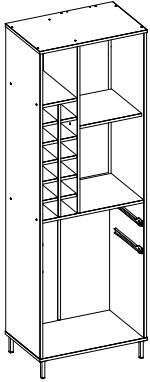

HARDWARE REQUIRED

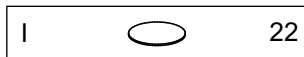
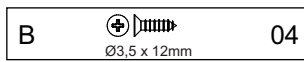

TOOLS REQUIRED

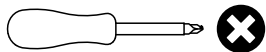

If desired, after assembly use an alcohol cleaner to erase the number printed on the parts.

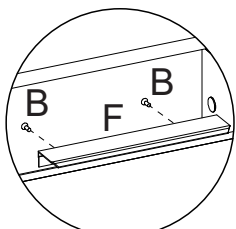
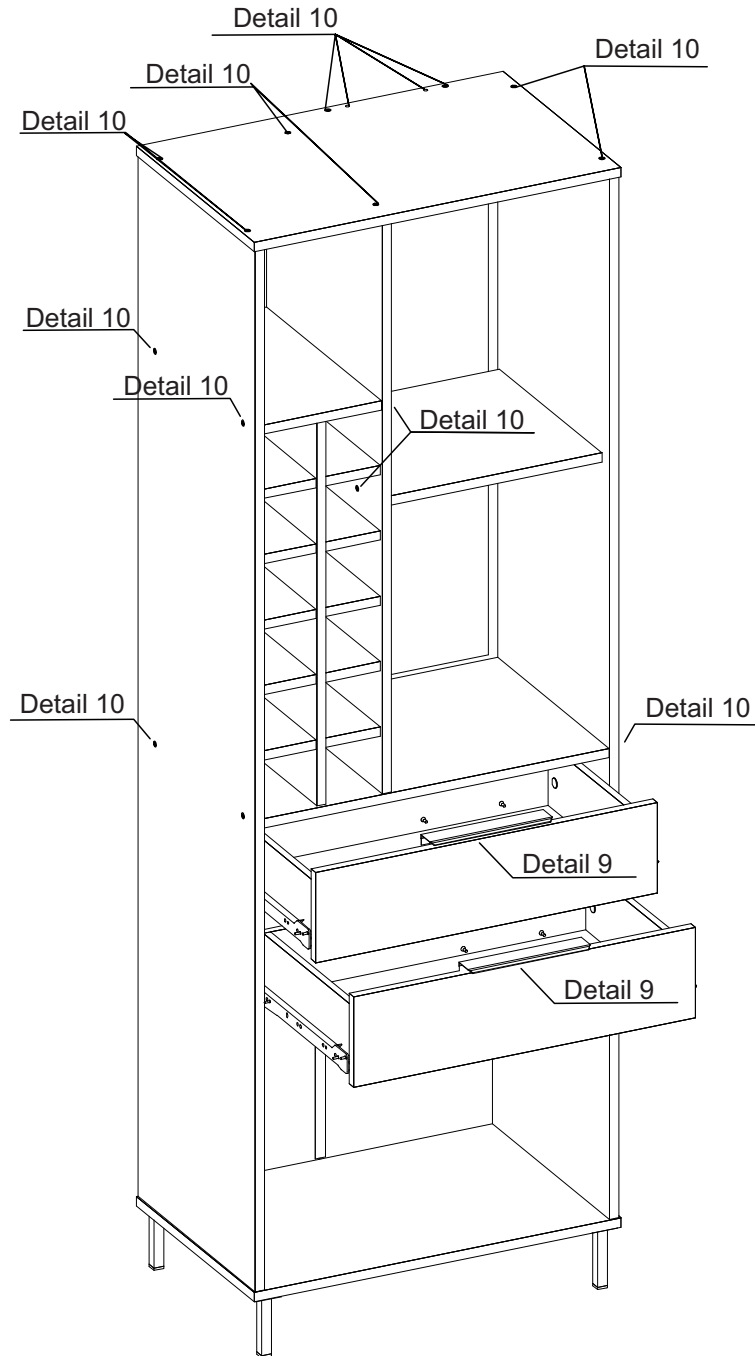

Detail 9

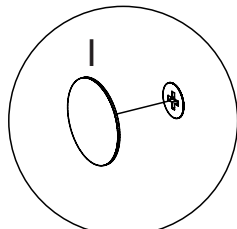

Detail 10

WARNING

Serious or fatal injuries can occur from furniture tipping over. To prevent the furniture from tipping over we recommend that it is permanently fixed to the wall.

Wall fixings are not supplied with this product as different wall materials require different types of fixing devices.

Please make sure you use fixings suitable for the walls in your home.

