

BUDGET BUTTERFLY DINING SET ASSEMBLY INSTRUCTIONS



MAX TABLE
WEIGHT



MAX CHAIR
WEIGHT

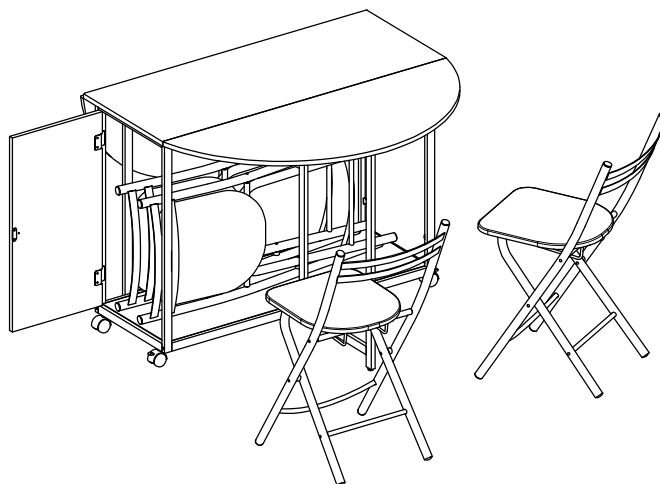

IMPORTANT FOR DOMESTIC USE ONLY PLEASE READ BEFORE YOU CONTINUE FURTHER

THE PRODUCT YOU HAVE PURCHASED WILL GIVE YOU MANY YEARS OF SERVICE IF YOU FOLLOW THE GUIDELINES FOR ITS SAFE ASSEMBLY AND PERIODIC MAINTENANCE AND CLEANING .

ASSEMBLE ON A SOFT CLEAN SURFACE

DO NOT USE ANY TOOLS OTHER THAN THOSE SHOWN.

ANY SPANNERS OR ALLEN KEYS REQUIRED ARE INCLUDED WITH THE FITTINGS KIT.

DO NOT FOR ANY REASON USE A POWER TOOL TO ASSEMBLE THIS PRODUCT. ITS USE WILL INVALIDATE ANY CLAIM YOU MAY HAVE AND COULD MAKE THIS PRODUCT UNSAFE.

DEPENDING ON THE AMOUNT OF USE THIS PRODUCT RECEIVES IT MAY BE NECESSARY TO TIGHTEN UP THE FIXINGS FROM TIME TO TIME . THIS IS COMPLETELY NORMAL FOR ANY FLAT PACK FURNITURE.
DO NOT OVERTIGHTEN FIXINGS.

FOR CLEANING, YOU MAY USE A DAMP CLOTH (NOT WET) DO NOT USE POLISH, DETERGENT OR CHEMICAL CLEANERS.

THIS PRODUCT MAY STAIN OR MARK IF ALLOWED TO COME INTO CONTACT WITH WET OR DAMP OBJECTS.

THE SURFACE OF THIS ITEM IS NOT HEAT RESISTANT. ALWAYS USE A PLACE MAT UNDER HOT OR COLD ITEMS TO PREVENT MARKING.

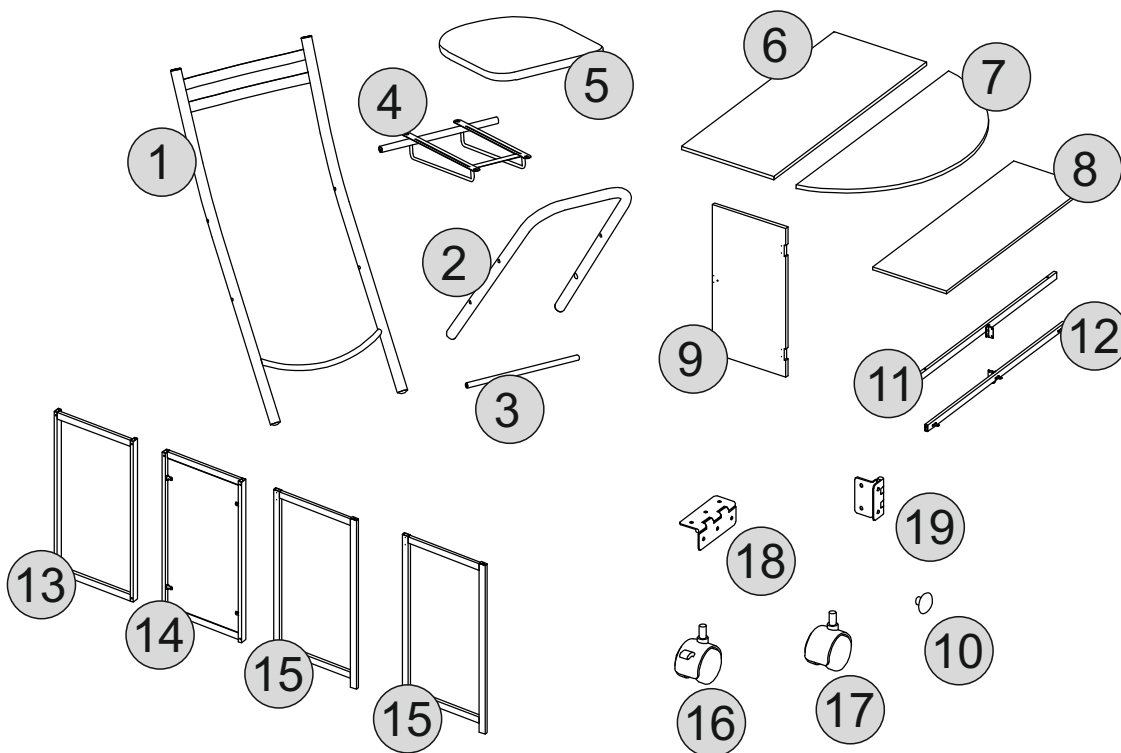











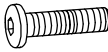
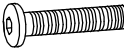
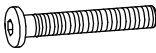



PARTS LIST

Part Number	Part Code	Part Description	Quantity	Carton
1	S400-401-022-WJ1-01	Chair Backrest	4	1/1
2	S400-401-022-WJ1-02	Chair Leg	4	1/1
3	S400-401-022-WJ1-03	Chair Cross Bar	4	1/1
4	S400-401-022-WJ1-04	Chair Seat Frame	4	1/1
5	S400-401-022-WJ1-05	Chair Seat Board	4	1/1
6	S400-401-022-WJ1-06	Table Top (Central)	1	1/1
7	S400-401-022-WJ1-07	Foldable Table Top	2	1/1
8	S400-401-022-WJ1-08	Lower Board	1	1/1
9	S400-401-022-WJ1-09	Door	1	1/1
10	S400-401-022-WJ1-10	Door Handle	1	1/1
11	S400-401-022-WJ1-11	Upper Crossbar	2	1/1
12	S400-401-022-WJ1-12	Lower Cross Bar	2	1/1
13	S400-401-022-WJ1-13	Door Frame	1	1/1
14	S400-401-022-WJ1-14	Frame With Board	1	1/1
15	S400-401-022-WJ1-15	Foldable Frame	2	1/1
16	S400-401-022-WJ1-16	Castor With Brakes	2	1/1
17	S400-401-022-WJ1-17	Castor	2	1/1
18	S400-401-022-WJ1-18	Hinge For Table Top	6	1/1
19	S400-401-022-WJ1-19	Hinge For Door	2	1/1

PLEASE CHECK THAT YOU HAVE ALL THE PARTS LISTED BEFORE YOU START ASSEMBLING. IF YOU DO FIND THAT SOMETHING IS MISSING, DO NOT CONTINUE ASSEMBLY. PLEASE CONTACT YOUR SUPPLIER IMMEDIATELY.

HARDWARE LIST

REF		HARDWARE NAME	QTY
A		M6 x 12MM	16PCS
B		M6 x 25MM	8PCS
C		M6 x 35MM	4PCS
D		M6 x 45MM	16PCS
E		M6 x 65MM	8PCS
F		4 x 12MM SCREW	58PCS
G		3 x 12MM SCREW	4PCS
H		M4 x 20MM BOLT	1PC
I		M6 x 25MM BOLT	2PCS
J		M6 NUT	8PCS
K		Wood Screw	8PCS
L		TABLE FOOT	2PCS
M		DOOR CATCH	1PC
O		METAL CATCH	1PC
P		ALLEN KEY 4MM	1PC
Q		M6 SPANNER	1PC
R		M6 (FOR CASTOR)	1PC

PLEASE CHECK THAT YOU HAVE ALL THE PARTS LISTED BEFORE YOU START ASSEMBLING. IF YOU DO FIND THAT SOMETHING IS MISSING, DO NOT CONTINUE ASSEMBLY. PLEASE CONTACT YOUR SUPPLIER IMMEDIATELY.

STEP 1

PARTS REQUIRED

2 - CHAIR LEG x4

4 - CHAIR SEAT FRAME x4

HARDWARE REQUIRED

TOOLS REQUIRED

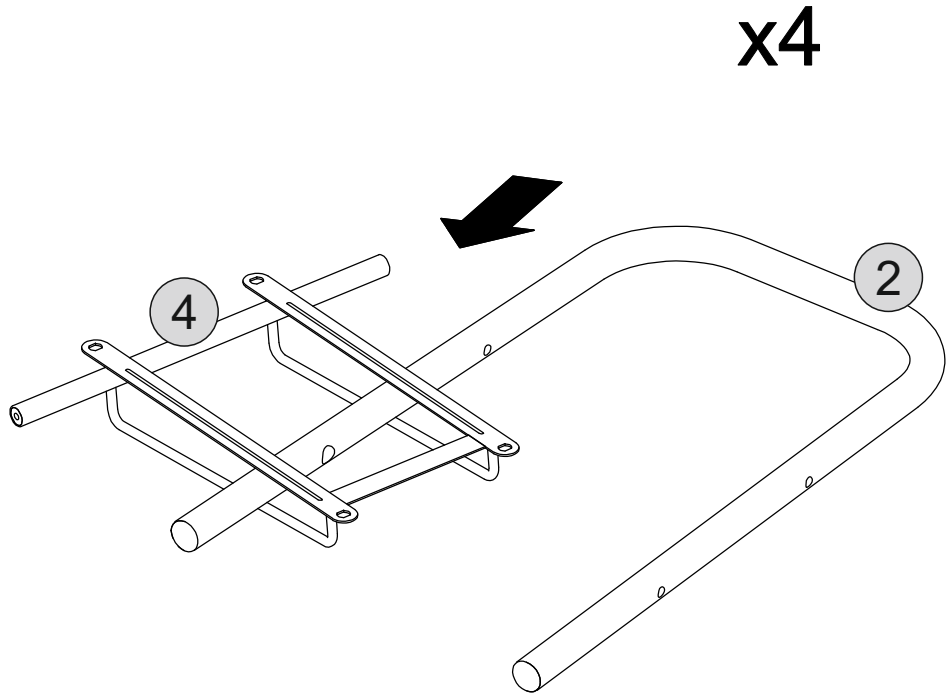

STEP 2

PARTS REQUIRED

3 - CHAIR CROSSBAR x4

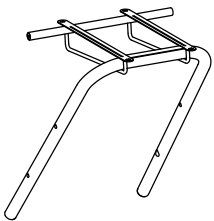

HARDWARE REQUIRED

B  08
M6x25MM

TOOLS REQUIRED

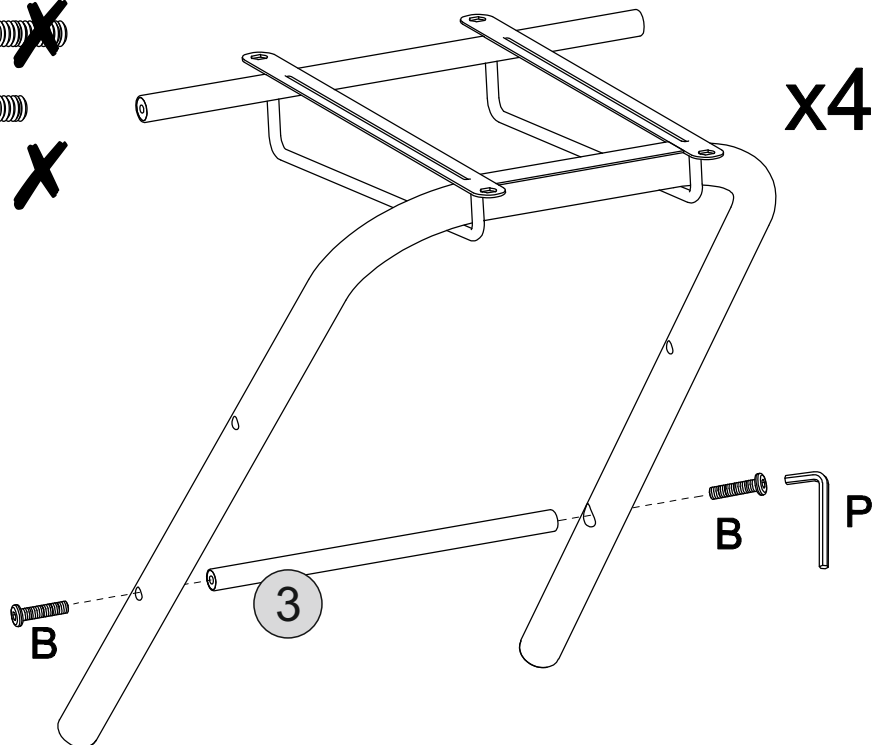
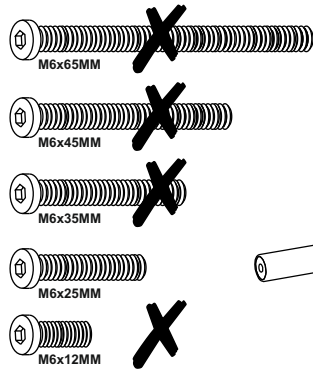

STEP 3

PARTS REQUIRED

1 - CHAIR BACKREST x4

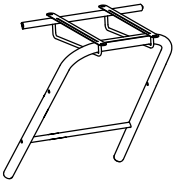

HARDWARE REQUIRED

D  M6x45MM 08

E  M6x65MM 08

J  08

K  08

TOOLS REQUIRED

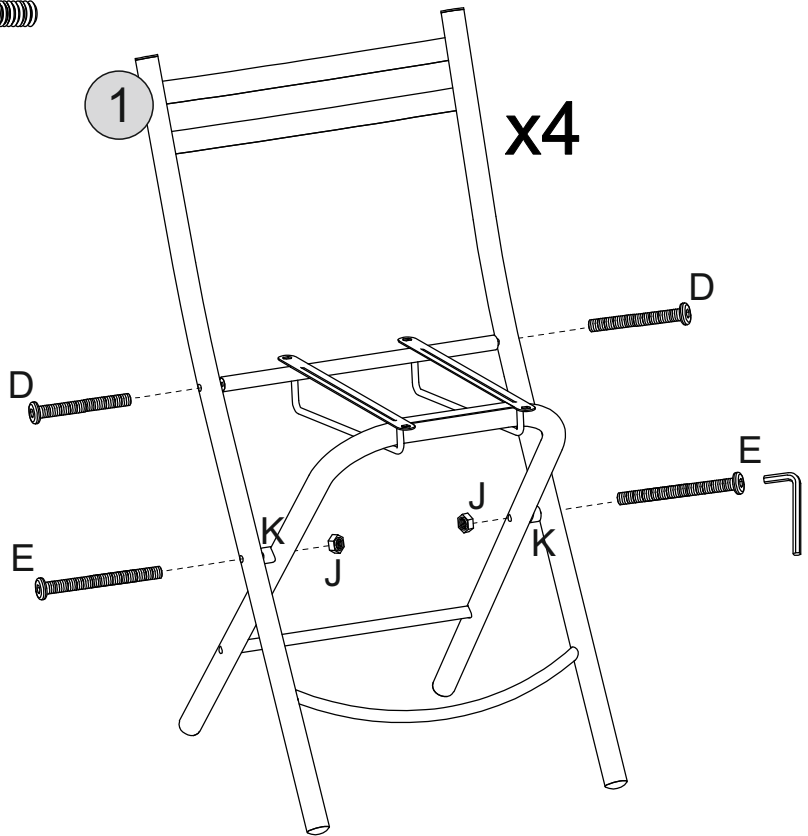
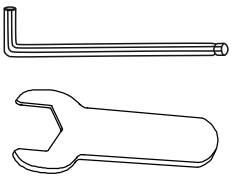

x4

STEP 4

PARTS REQUIRED

5 - CHAIR SEAT BOARD x4

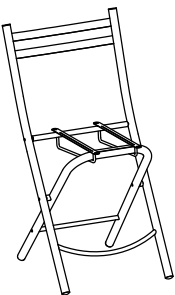

HARDWARE REQUIRED

A  M6x12MM 16

TOOLS REQUIRED

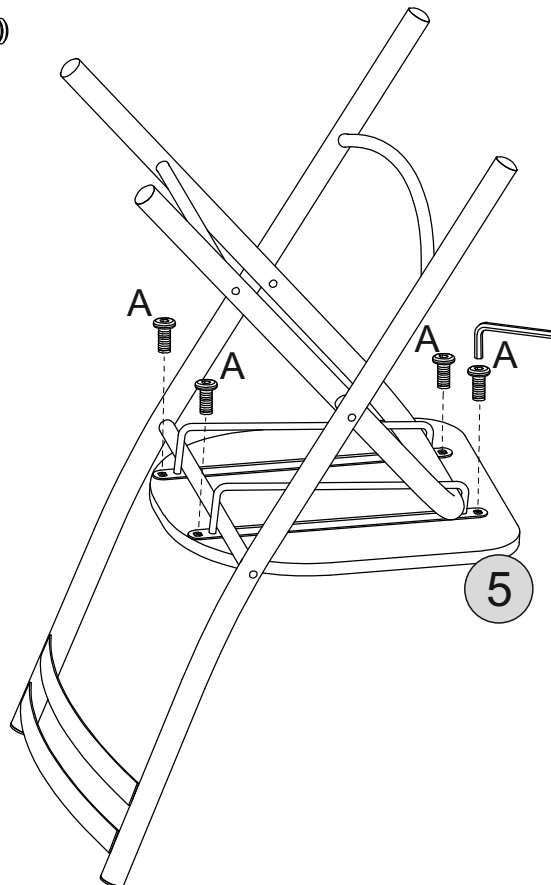

x4

5

STEP 5

PARTS REQUIRED

11 - UPPER CROSSBAR x2

12 - LOWER CROSSBAR x2

13 - DOOR FRAME x1

14 - FRAME WITH BOARD x1

HARDWARE REQUIRED

D  08

TOOLS REQUIRED

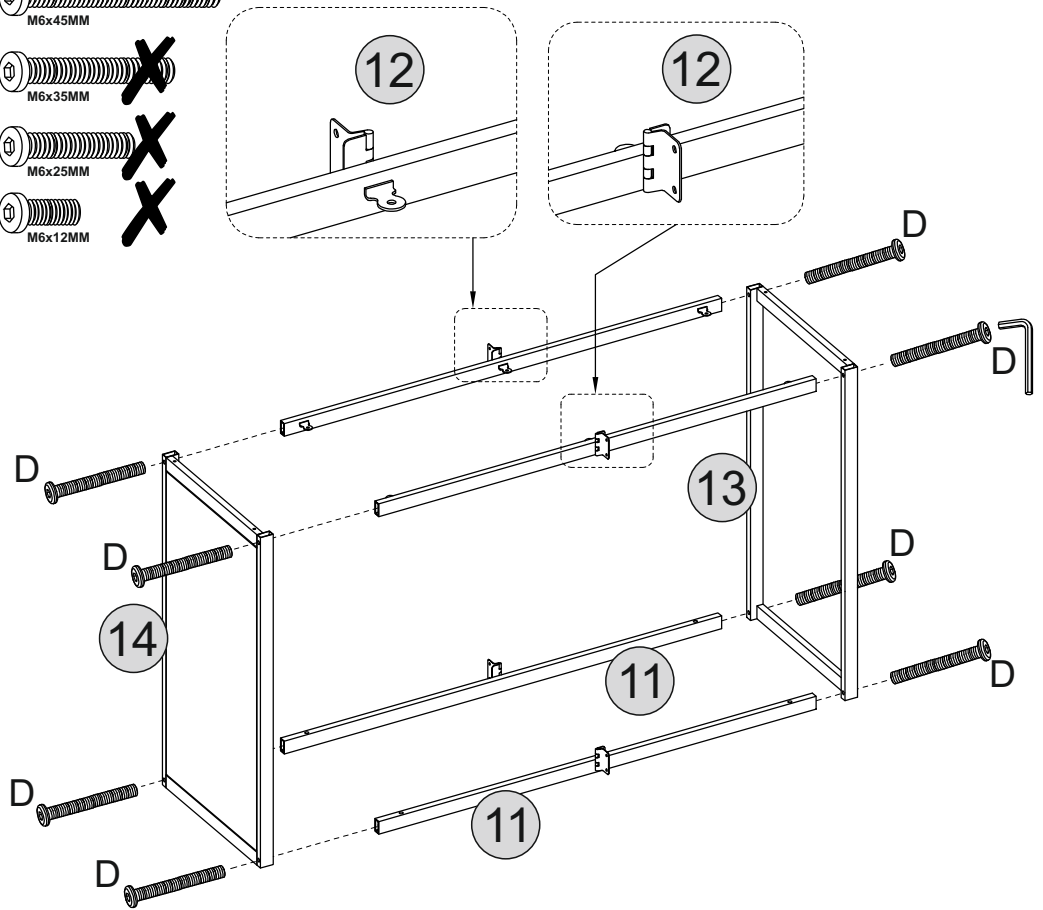

STEP 6

PARTS REQUIRED

16 - CASTOR WITH BRAKES x2

17 - CASTOR x2

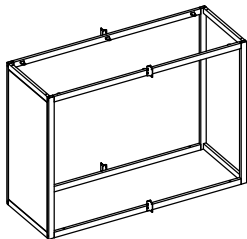

HARDWARE REQUIRED

TOOLS REQUIRED

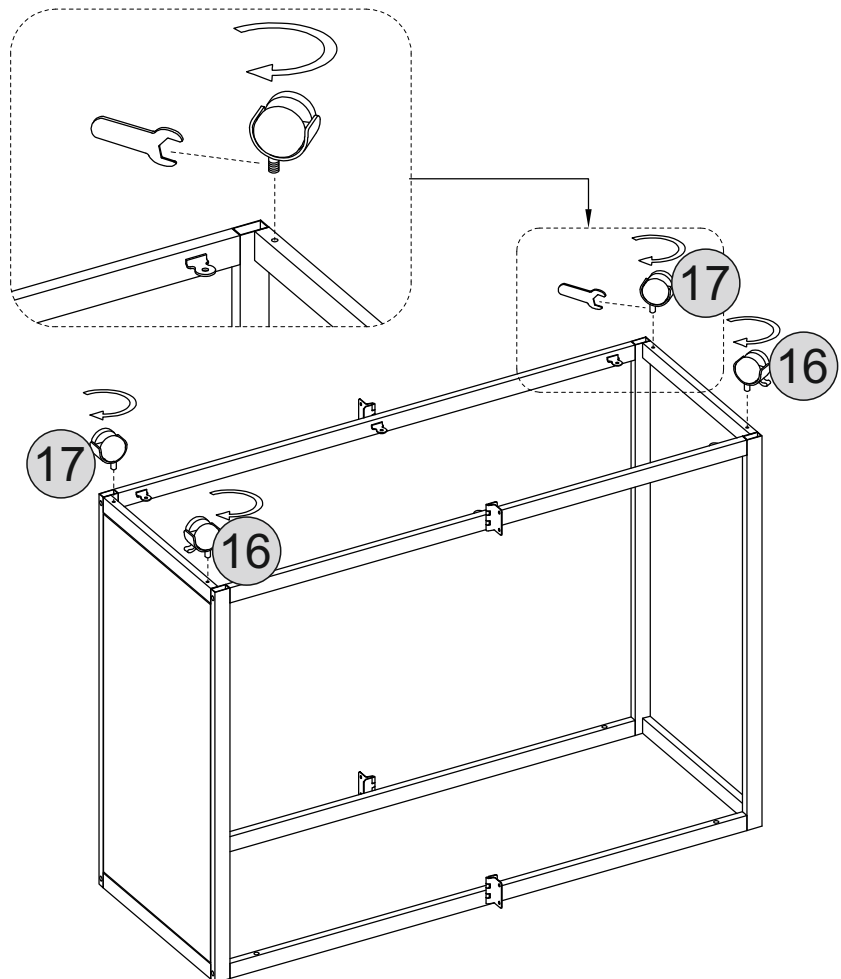
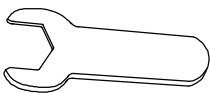

STEP 7

PARTS REQUIRED

15 - FOLDABLE FRAME x2

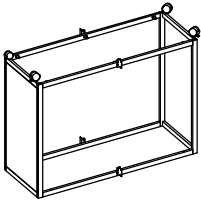

HARDWARE REQUIRED

F  08

L  02

TOOLS REQUIRED

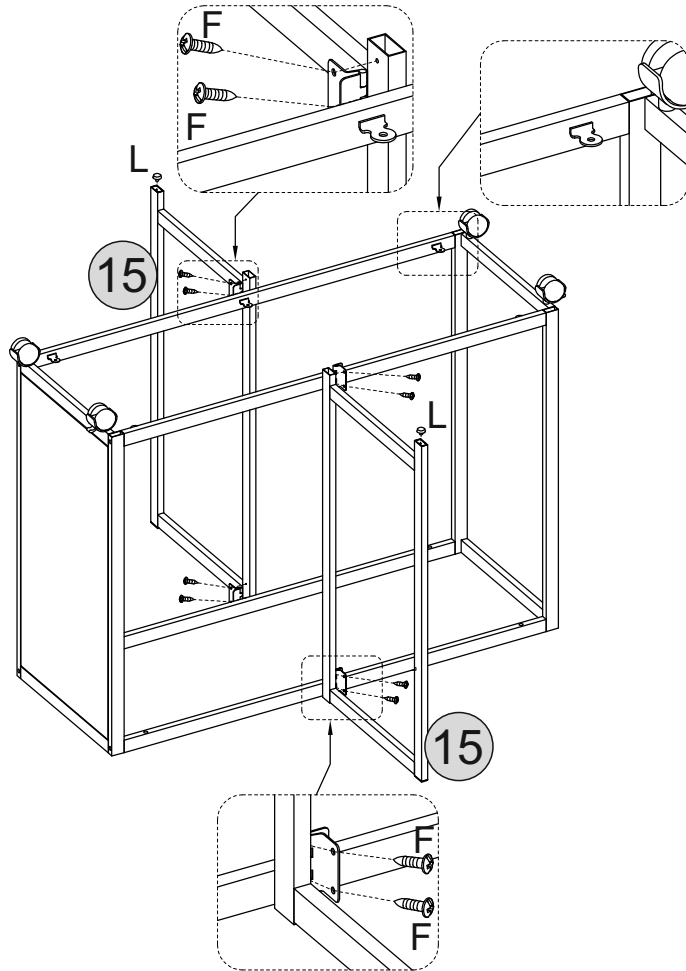
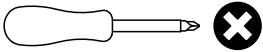

STEP 8

PARTS REQUIRED

6 - TABLE TOP CENTRAL x1

8 - LOWER BOARD x1

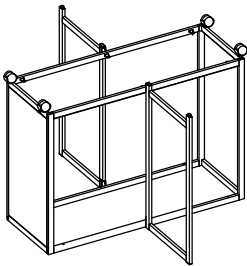

HARDWARE REQUIRED

C  04

F  06

TOOLS REQUIRED

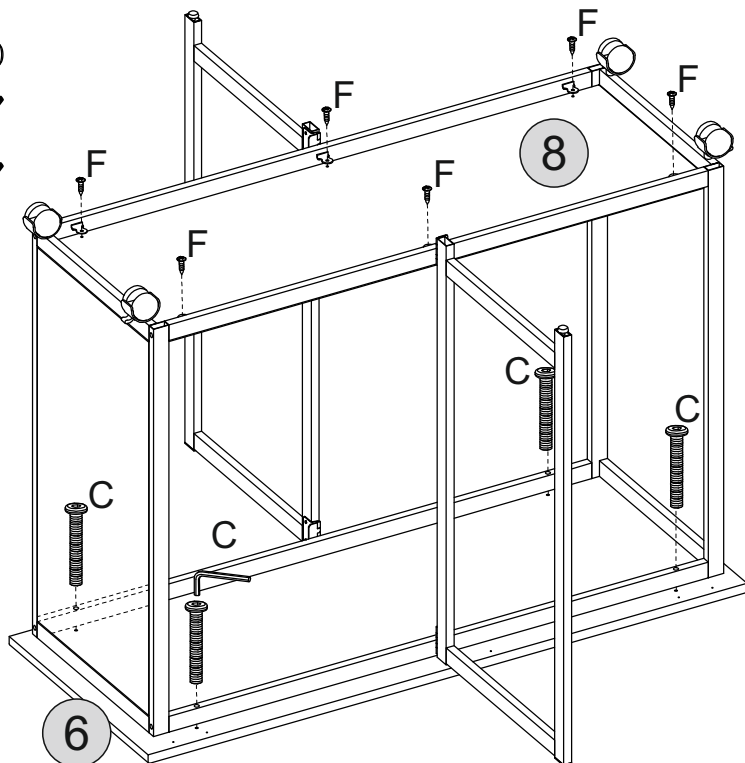
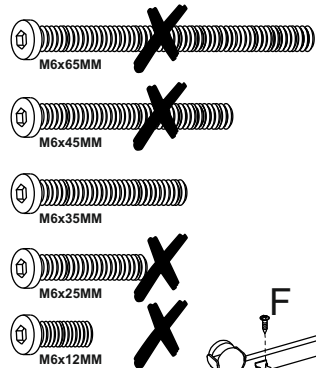
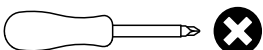

STEP 9

PARTS REQUIRED

7 - FOLDABLE TABLE TOP x2

18 - HINGE FOR TABLE TOP x6

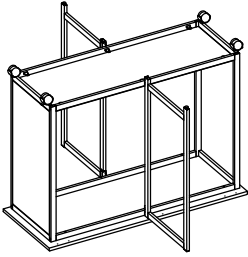

HARDWARE REQUIRED

F  36

I  02

TOOLS REQUIRED

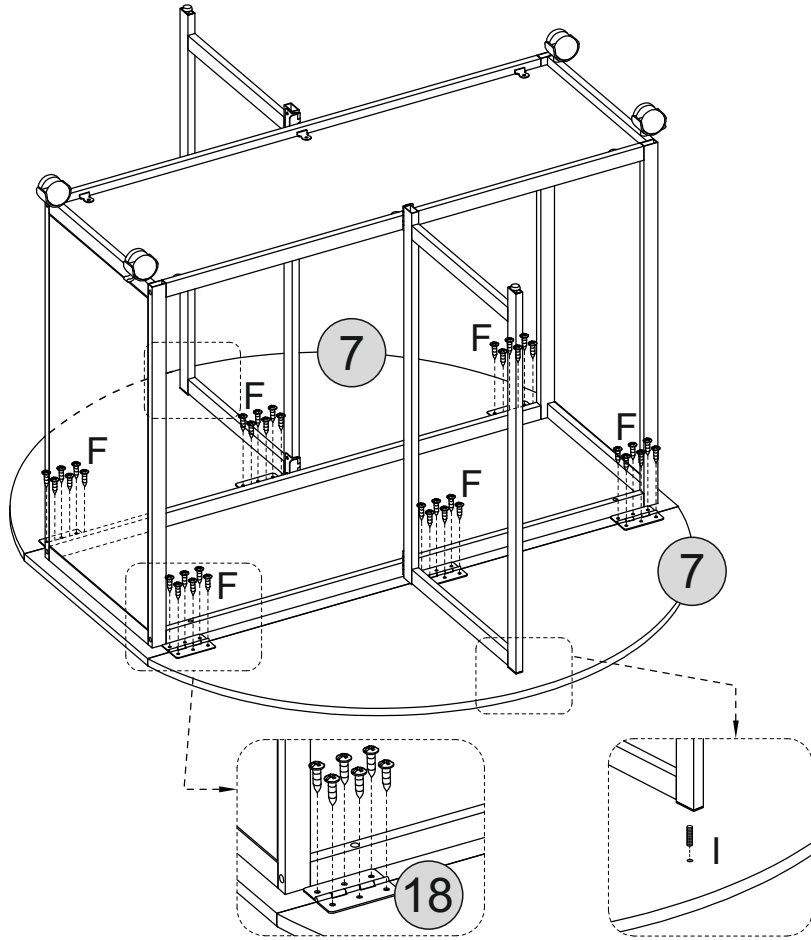
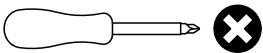

STEP 10

PARTS REQUIRED

9 - DOOR x1

19 - HINGE FOR DOOR x1

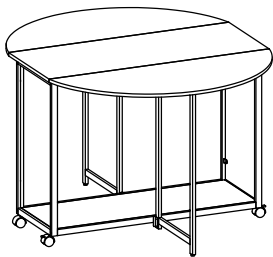

HARDWARE REQUIRED

F  08

G  02

O  01

TOOLS REQUIRED

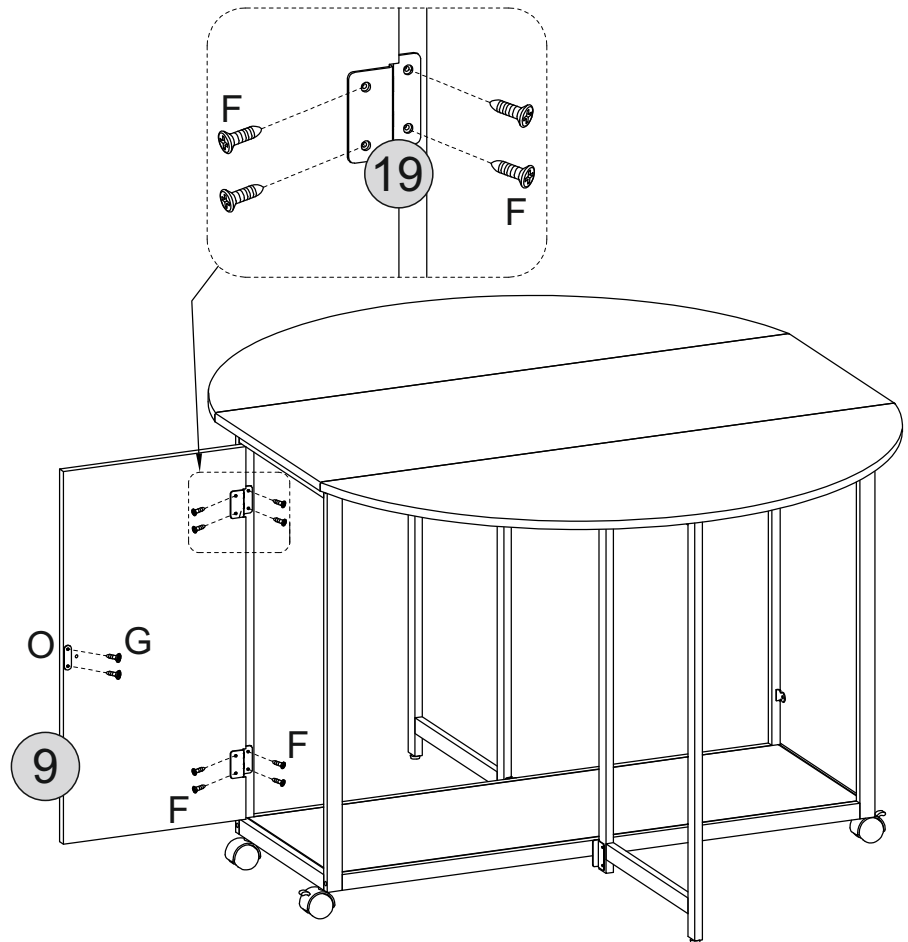
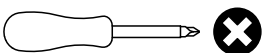

STEP 11

PARTS REQUIRED

10 - DOOR HANDLE x1



HARDWARE REQUIRED

G  02

H  01

M  01

TOOLS REQUIRED

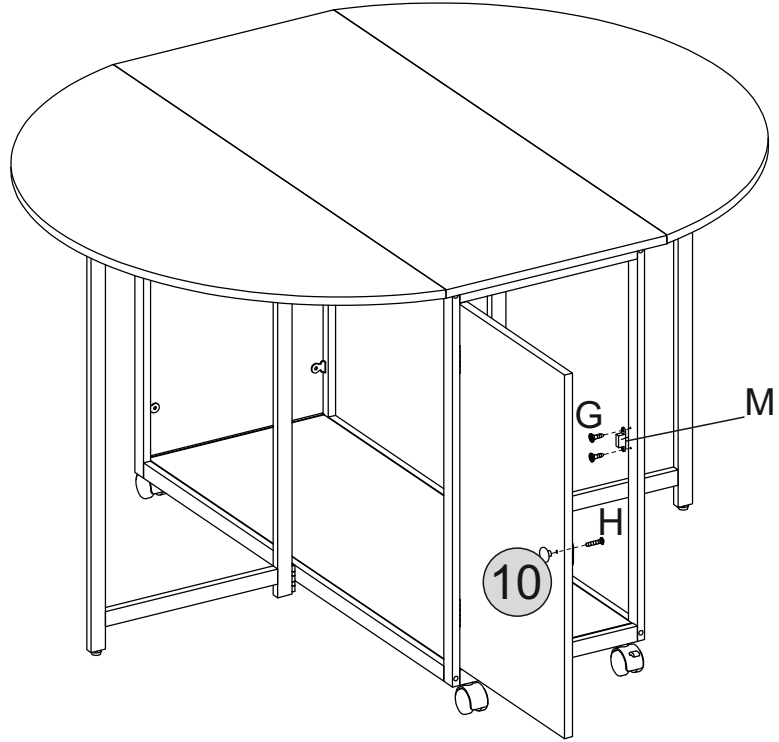
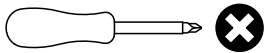

STEP 12

PARTS REQUIRED

HARDWARE REQUIRED

TOOLS REQUIRED



MAX TABLE WEIGHT



MAX CHAIR WEIGHT