

# SALVADOR DINING TABLE ASSEMBLY INSTRUCTIONS

52698

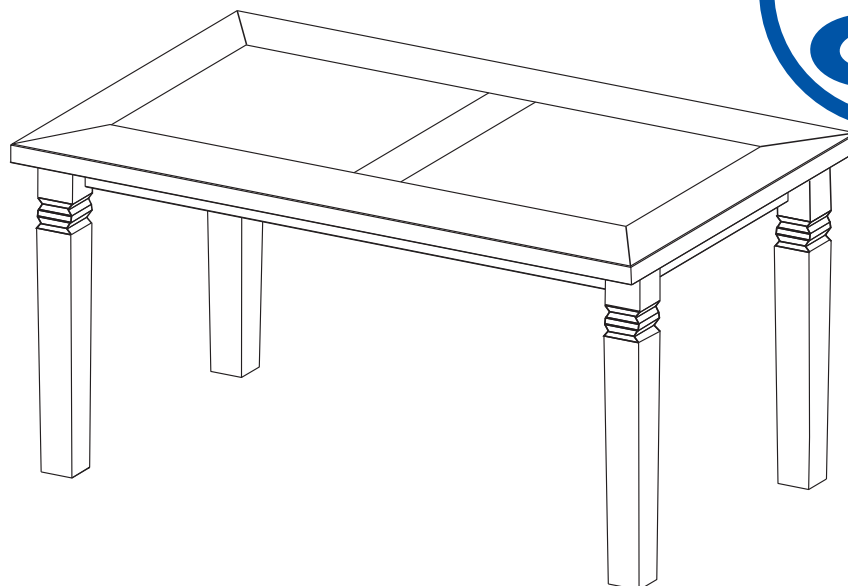

**FOR DOMESTIC USE ONLY**

**IMPORTANT**

**PLEASE READ BEFORE YOU CONTINUE FURTHER**

## **CARE AND MAINTENANCE**

After unpacking this product please keep the original packaging in case it needs to be returned for any reason.

- Please ensure all fittings and parts are present before commencing with assembly.
- We recommend that you lay a blanket or sheet on the floor to avoid damage to both your floor and the product.
- We strongly recommend that you keep children away from your work area.
- Assemble this product as close to its final position as possible.
- Never drag or push products as this could cause damage to the joints making it inferior.
- Do not place this product next to a radiator or in direct sunlight.
- Wood is a natural product and may expand if subjected to damp and may shrink or crack if subjected to heat. Therefore it is recommended that room temperature is maintained, with no sudden temperature fluctuations.
- Make sure any spillage is wiped off immediately.
- Do not place hot or chilled items directly on to the surface, use a place mat or marking will occur.
- For general cleaning use a duster, and do not use detergents of any kind. However, the surface will need to be retreated from time to time. This can be done by using block wax (unperfumed) and rubbing it over the whole item.
- From time to time it may be necessary to tighten fittings, regular inspections should be carried out.

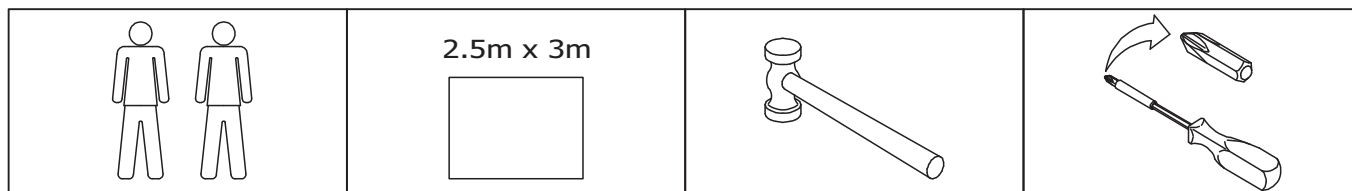
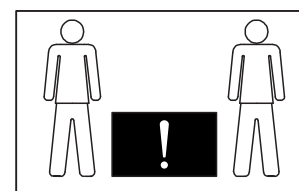
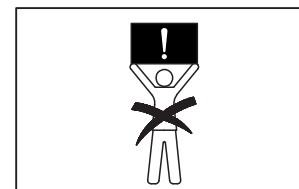
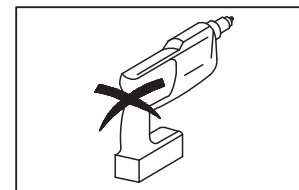
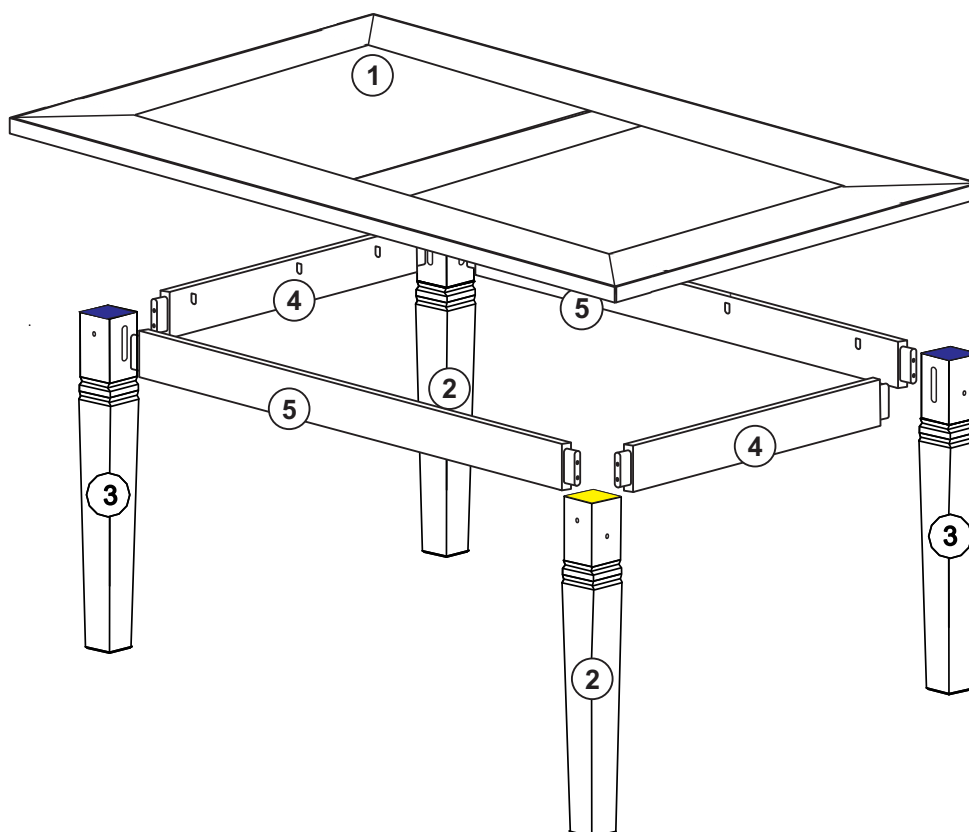





\* Use of power tools to assemble this product will invalidate any claim and could damage this product making it unsafe!!!  
 \* Please assemble on a clean soft surface to avoid damage.

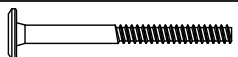

\* Please check contents and read the instructions before commencing assembly  
 \* Assemble this product following the enclosed instructions carefully.  
 \* Please take care to avoid damaging parts during assembly.

### FITTINGS

<b>A</b>	 Ø7 x 100 BLACK	<b>08</b>
<b>B</b>		<b>01</b>

<b>C</b>	 4,0 x 40	<b>14</b>
<b>D</b>	 GLUE	<b>01</b>

### PARTS LIST

part number	name of part	quantity
<b>1</b>	Table Top	<b>1</b>
<b>2</b>	Table Leg (yellow marking)	<b>2</b>

part number	name of part	quantity
<b>3</b>	Table Leg (blue marking)	<b>2</b>
<b>4</b>	Short frame side	<b>2</b>

part number	name of part	quantity
<b>5</b>	Long frame side	<b>2</b>

# STEP 1

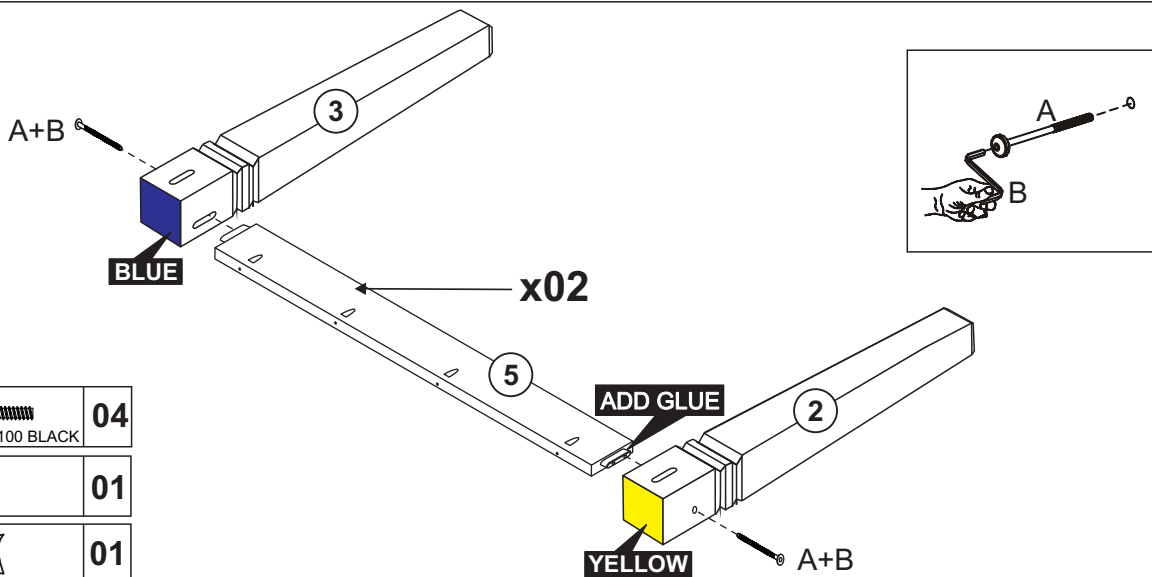

A		04
Ø7 x 100 BLACK		

B		01
---	--	----

D		01
GLUE		

# STEP 2

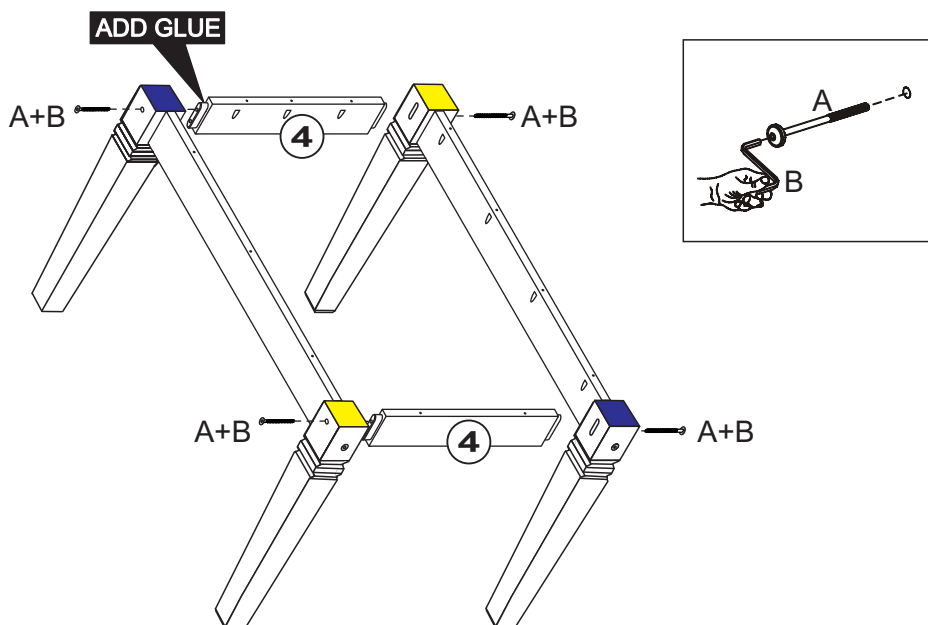

A		04
Ø7 x 100 BLACK		

B		01
---	--	----

D		01
GLUE		

# STEP 3

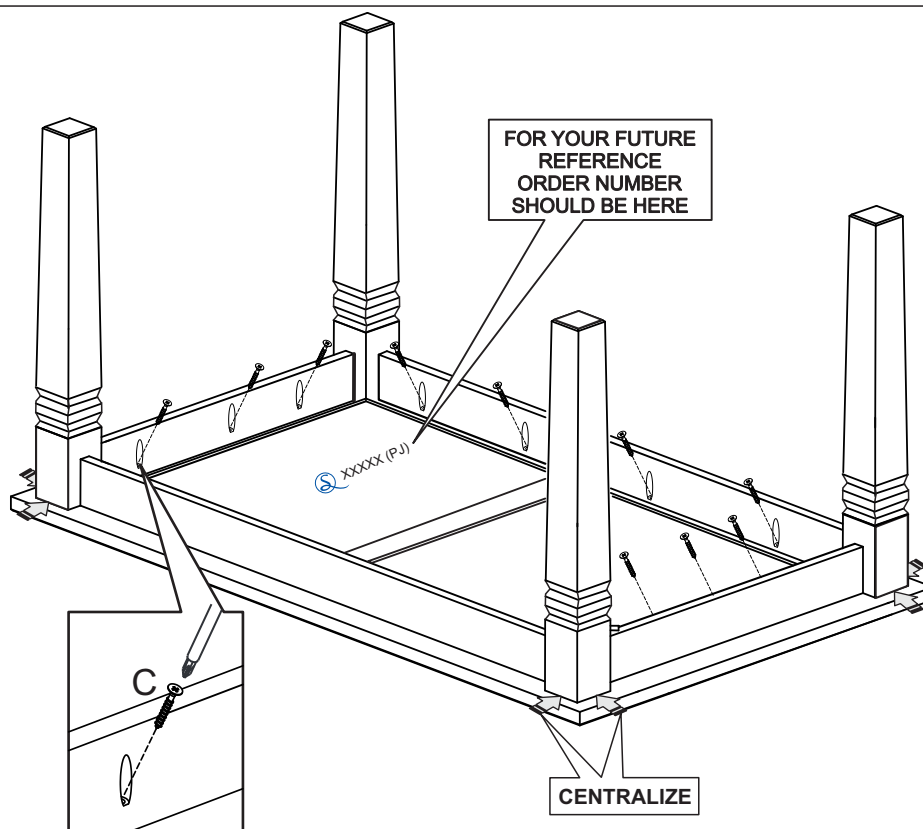

C		14
4,0 x 40		

# SALVADOR DINING CHAIR

## ASSEMBLY INSTRUCTIONS

52564



MAX CHAIR  
WEIGHT

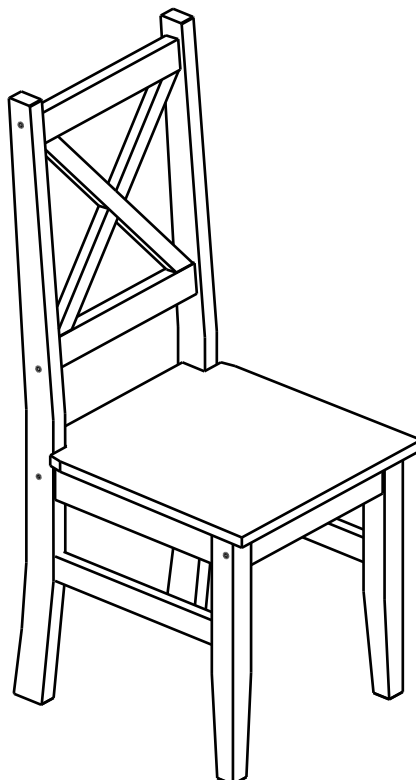

FOR DOMESTIC USE ONLY  
IMPORTANT

PLEASE READ BEFORE YOU CONTINUE FURTHER

## CARE AND MAINTENANCE

After unpacking this product please keep the original packaging in case it needs to be returned for any reason.

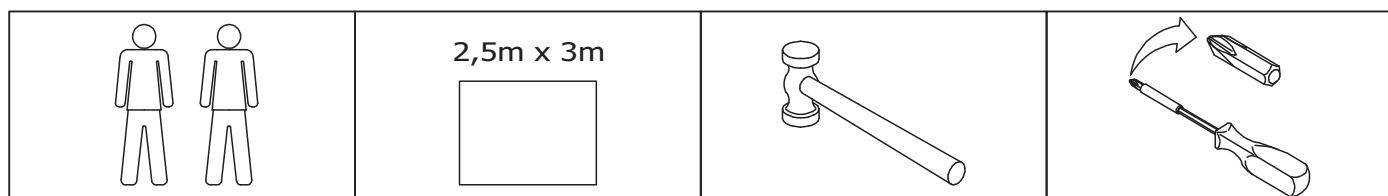
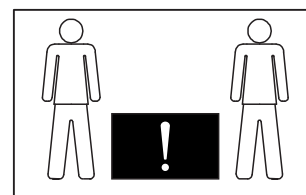
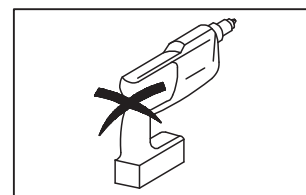
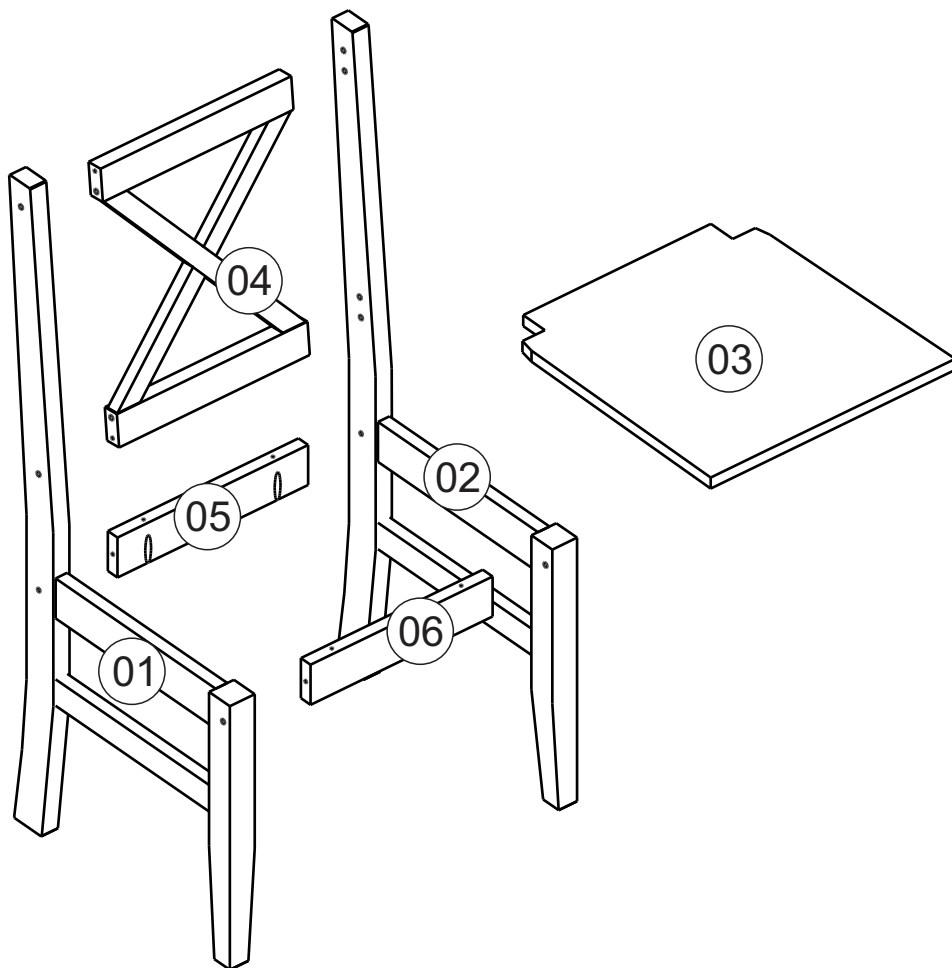

- Please ensure all fittings and parts are present before commencing with assembly.
- We recommend that you lay a blanket or sheet on the floor to avoid damage to both your floor and the product.
- We strongly recommend that you keep children away from your work area.
- Assemble this product as close to its final position as possible.
- Never drag or push products as this could cause damage to the joints making it inferior.
- Do not place this product next to a radiator or in direct sunlight.
- Wood is a natural product and may expand if subjected to damp and may shrink or crack if subjected to heat. Therefore it is recommended that room temperature is maintained, with no sudden temperature fluctuations.
- Make sure any spillage is wiped off immediately.
- Do not place hot or chilled items directly on to the surface, use a place mat or marking will occur.
- For general cleaning use a duster, and do not use detergents of any kind. However, the surface will need to be retreated from time to time. This can be done by using block wax (unperfumed) and rubbing it over the whole item.
- From time to time it may be necessary to tighten fittings, regular inspections should be carried out.





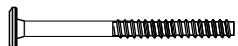

\* Use of power tools to assemble this product will invalidate any claim and could damage this product making it unsafe!!!  
 \* Please assemble on a clean soft surface to avoid damage.

\* Please check contents and read the instructions before commencing assembly.  
 \* Assemble this product following the enclosed instructions carefully.  
 \* Please take care to avoid damaging parts during assembly.

**FITTINGS**

<b>A</b>		Ø 7 x 80 BLACK	<b>02</b>	<b>04</b>
<b>B</b>		Ø 7 x 60 BLACK	<b>06</b>	<b>12</b>

<b>C</b>		8,0 x 30	<b>04</b>	<b>08</b>
<b>D</b>		4,0 x 35	<b>04</b>	<b>08</b>

<b>E</b>		GLUE	<b>01</b>
<b>F</b>			<b>01</b>

**PARTS REQUIRED PER A CHAIR**

part number	name of part	quantity
<b>1</b>	Left chair side	<b>1</b>
<b>2</b>	Right chair side	<b>1</b>

part number	name of part	quantity
<b>3</b>	Chair seat	<b>1</b>
<b>4</b>	Back rail	<b>1</b>

part number	name of part	quantity
<b>5</b>	Back seat rail (BIGGER)	<b>1</b>
<b>6</b>	Front seat rail (SMALLER)	<b>1</b>

### STEP 01

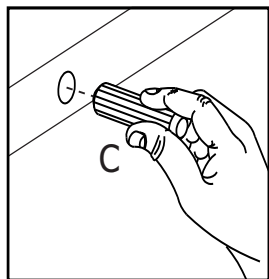
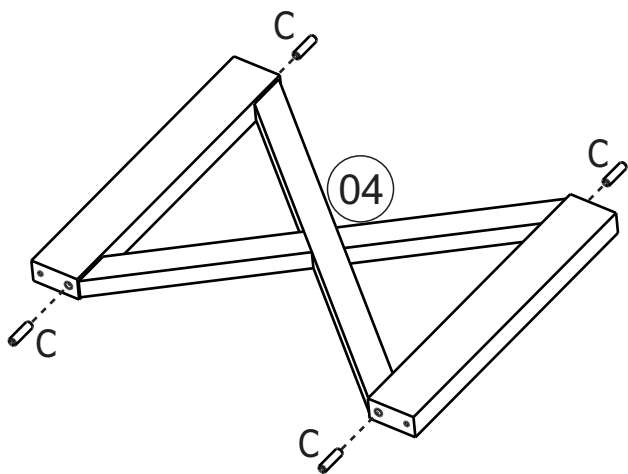
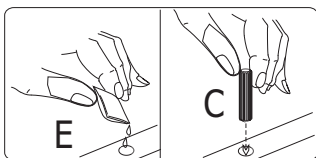



**!**  
Glue must be added to the dowel holes on parts 1,2 and 4.

E	GLUE	01
C		04

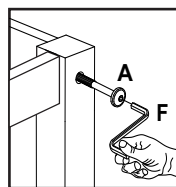
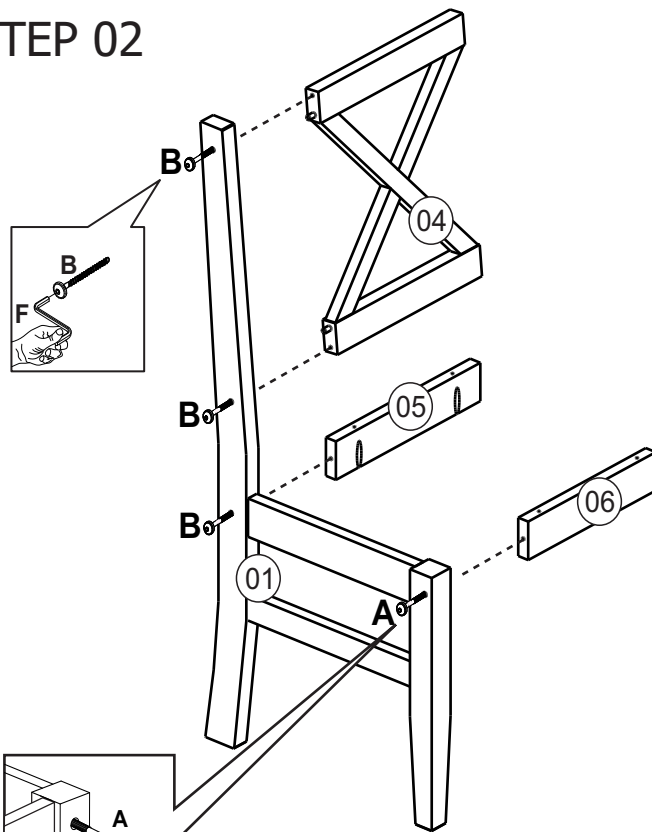
### STEP 02

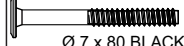

A		01
B		03
F		01

### STEP 03

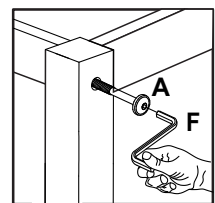
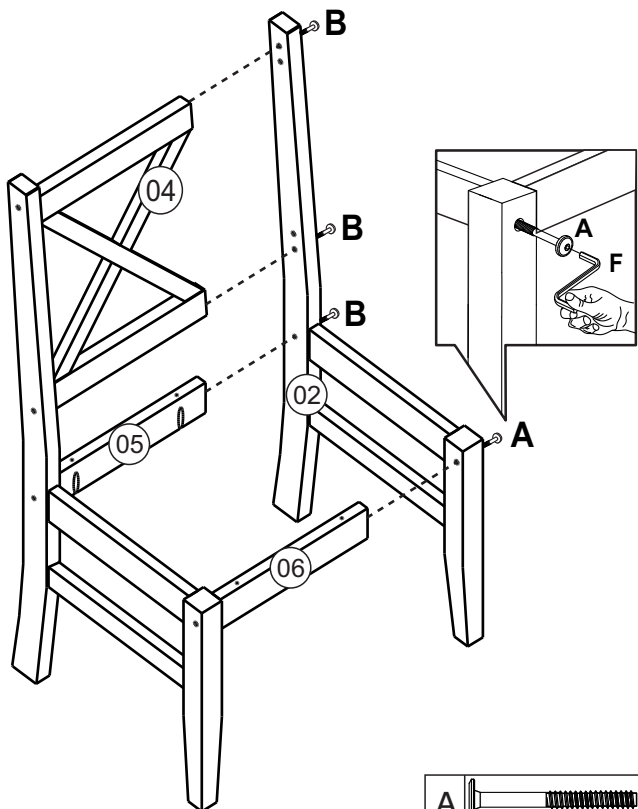

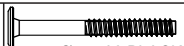
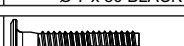
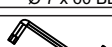
A		01
B		03
F		01

### STEP 04

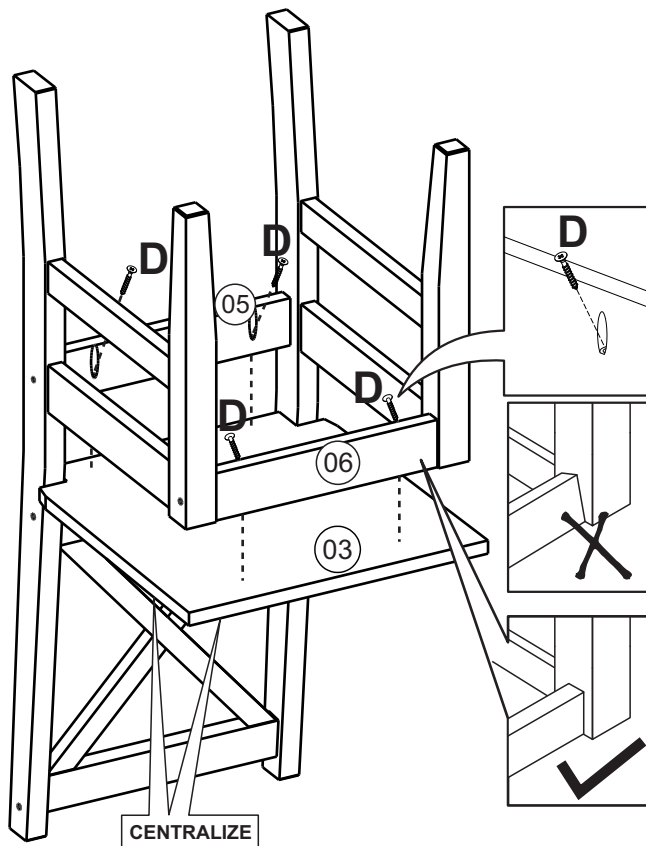

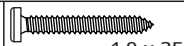
D		04
---	--	----

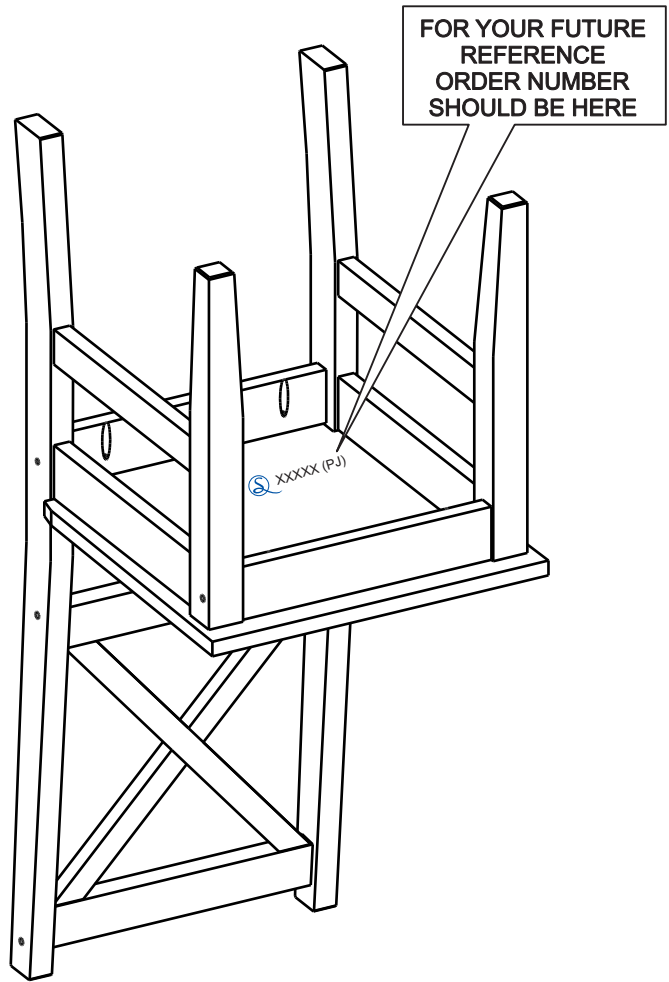

100KG  
MAX CHAIR  
WEIGHT