

# MILAN DINING TABLE ASSEMBLY INSTRUCTIONS

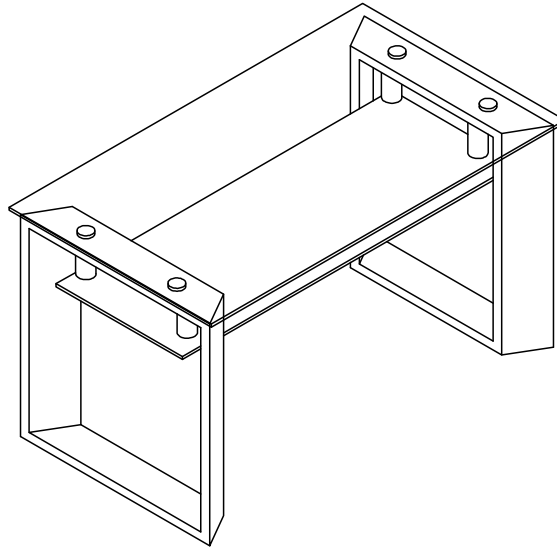
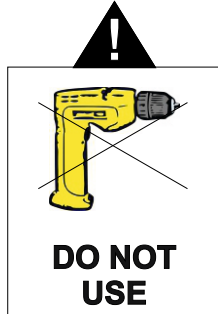

## IMPORTANT

### PLEASE READ BEFORE YOU CONTINUE FURTHER

THE PRODUCT YOU HAVE PURCHASED WILL GIVE YOU MANY YEARS OF SERVICE IF YOU FOLLOW THE GUIDELINES FOR ITS SAFE ASSEMBLY AND PERIODIC MAINTENANCE AND CLEANING .

ASSEMBLE ON A SOFT CLEAN SURFACE.

DO NOT USE ANY TOOLS OTHER THAN THOSE SHOWN.

ANY SPANNERS OR ALLEN KEYS REQUIRED ARE INCLUDED WITH THE FITTINGS KIT.

DO NOT FOR ANY REASON USE A POWER TOOL TO ASSEMBLE THIS PRODUCT. ITS USE WILL INVALIDATE ANY CLAIM YOU MAY HAVE AND COULD MAKE THIS PRODUCT UNSAFE.

DEPENDING ON THE AMOUNT OF USE THIS PRODUCT RECEIVES IT MAY BE NECESSARY TO TIGHTEN UP THE FIXINGS FROM TIME TO TIME . THIS IS COMPLETELY NORMAL FOR ANY FLAT PACK FURNITURE.  
DO NOT OVERTIGHTEN FIXINGS.

FOR CLEANING, YOU MAY USE A DAMP CLOTH (NOT WET) DO NOT USE POLISH, DETERGENT OR CHEMICAL CLEANERS.

THIS PRODUCT MAY STAIN OR MARK IF ALLOWED TO COME INTO CONTACT WITH WET OR DAMP OBJECTS.

THE SURFACE OF THIS ITEM IS NOT HEAT RESISTANT. ALWAYS USE A PLACE MAT UNDER HOT OR COLD ITEMS TO PREVENT MARKING.

## **CARE & MAINTENANCE INSTRUCTIONS**

**THIS PRODUCT INCLUDES TOUGHENED GLASS WITH NOMINAL THICKNESS 10/6MM THE GLASS IS CHIPPED OR BROKEN, PLEASE REPLACE WITH TYPE DESCRIBED OR ALTERNATIVELY CONSULT WITH THE RETAILER STATING THE MODEL DETAILS .**

### **WARNING**

- 1. MAXIMUM LOAD ON TOP - DO NOT EXCEED 40KGS IN WEIGHT.**
- 2. DO NOT SIT OR STAND ON GLASS SURFACES.**
- 3. DO NOT USE GLASS AS A CHOPPING SURFACE .  
DO NOT STRIKE GLASS WITH HAND OR POINTED ITEMS.**
- 4. DO NOT PLACE VERY HOT OR VERY COLD ITEMS ON THE GLASS SURFACES UNLESS ADEQUATELY THICK TABLE MATS ARE USED TO PREVENT SUCH ITEMS COMING INTO CONTACT WITH THE GLASS.**
- 5. WHEN CLEANING GLASS PANELS USE A DAMP CLOTH OR LEATHER WITH WASHING UP LIQUID OR SOFT SOAP IF NECESSARY.  
DO NOT USE WASHING POWDER OR ANY OTHER SUBSTANCES CONTAINING ABRASIVE SINCE THESE SUBSTANCES SCRATCH GLASS.**



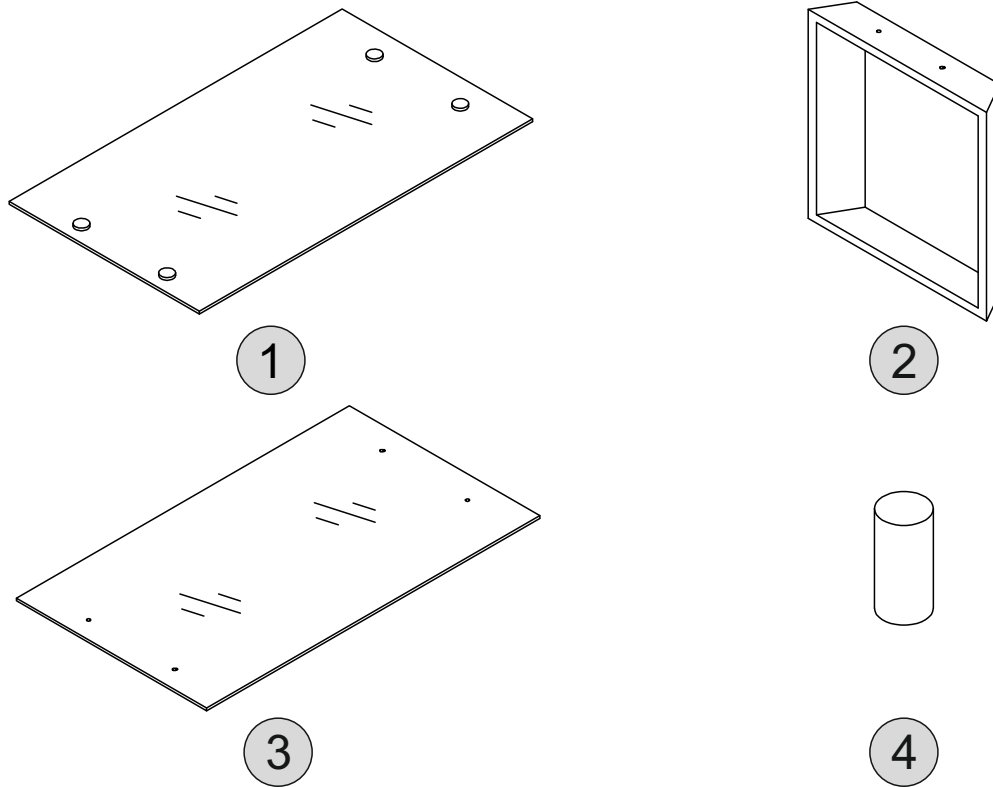



**KEEP THESE INSTRUCTIONS IN A SAFE PLACE FOR FUTURE REFERENCE  
THE GLASS USED IN THIS PRODUCT IS TOUGHENED AND CONFORMS TO BS 7376 2004**



## PARTS LIST

Part Number	Part Code	Part Description	Quantity	Carton
1	S400-401-134-SF1-01T	Table Top	1	1/2
2	S400-401-134-SF1-02T	Table Leg	2	2/2
3	S400-401-134-SF1-03T	Glass Shelf	1	1/2
4	S400-401-134-SF1-03T	Stainless Tube	4	1/2

## HARDWARE LIST

REF		HARDWARE NAME	QTY
A	 M10*114MM	METAL RODS	4PCS
B		PLASTIC WASHER PLATE	8PCS
C		WRENCH SOCKET	1PC
D		NUT	4PCS
E		METAL WASHER	4PCS
F		PLASTIC WASHER	4PCS

PLEASE CHECK THAT YOU HAVE ALL THE PARTS LISTED BEFORE YOU START ASSEMBLING. IF YOU DO FIND THAT SOMETHING IS MISSING, DO NOT CONTINUE ASSEMBLY. PLEASE CONTACT YOUR SUPPLIER IMMEDIATELY.

# STEP 1

**PARTS REQUIRED**

1 - TABLE TOP x1

**HARDWARE REQUIRED**

A  04

**TOOLS REQUIRED**

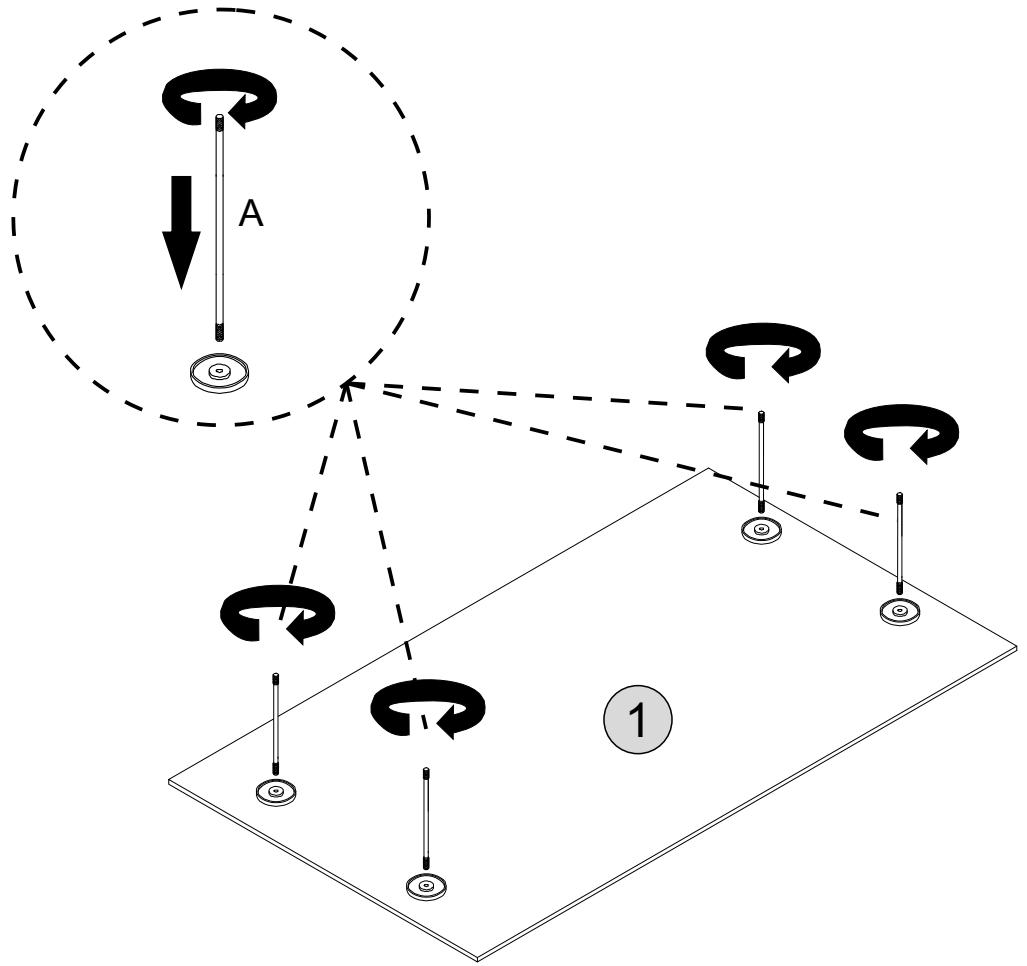

# STEP 2

**PARTS REQUIRED**

2 - TABLE LEG x2

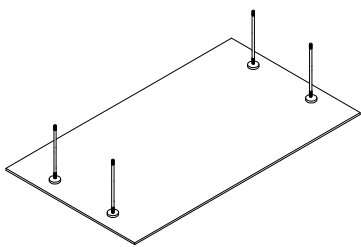

**HARDWARE REQUIRED**

**TOOLS REQUIRED**

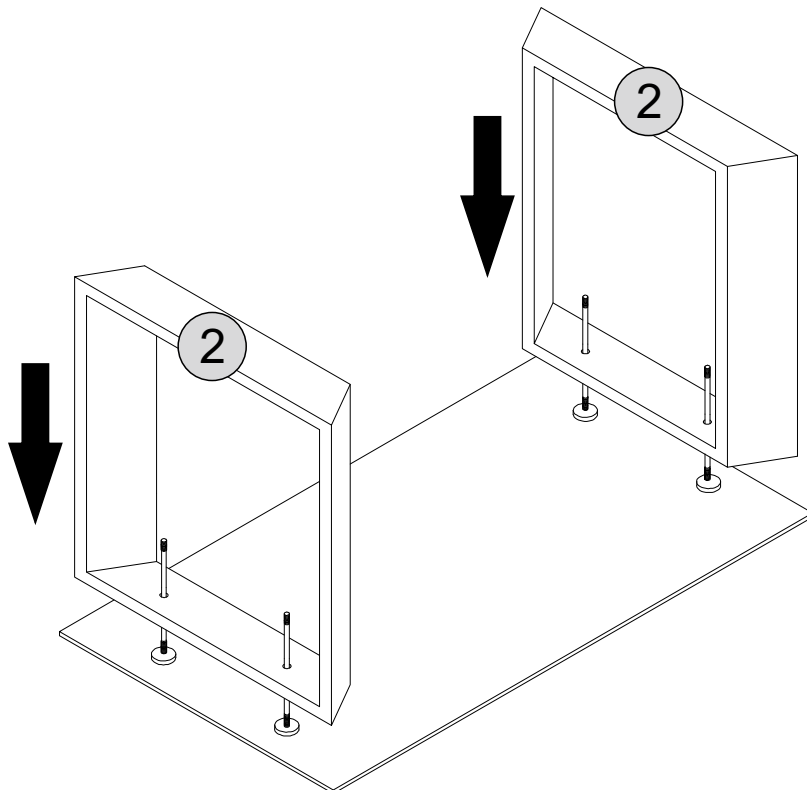

# STEP 3

**PARTS REQUIRED**

4 - STAINLESS TUBE x4

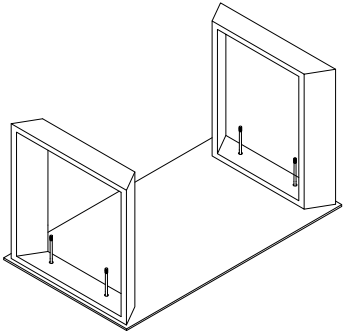

**HARDWARE REQUIRED**

B  08

**TOOLS REQUIRED**

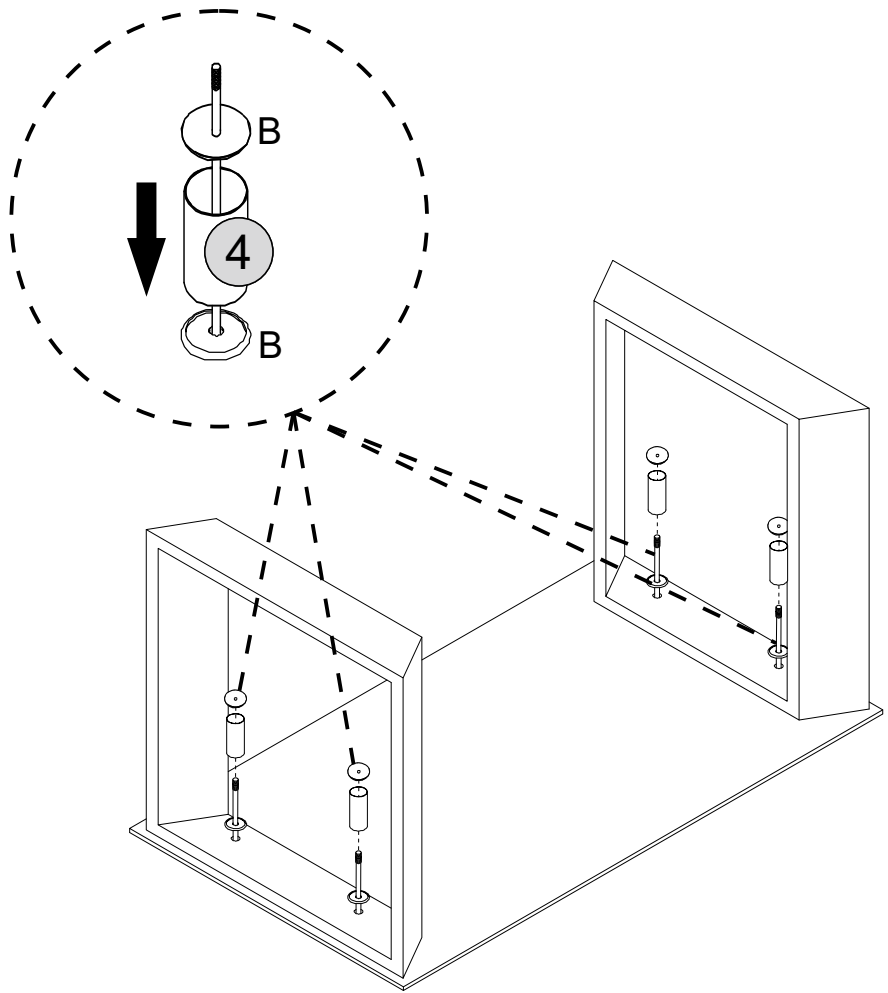

# STEP 4

**PARTS REQUIRED**

3 - GLASS SHELF x1

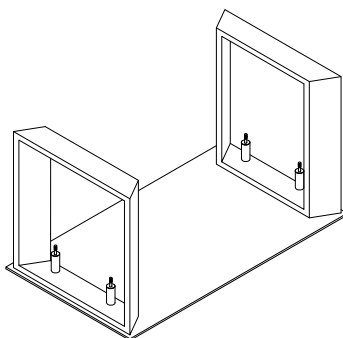

**HARDWARE REQUIRED**

**TOOLS REQUIRED**

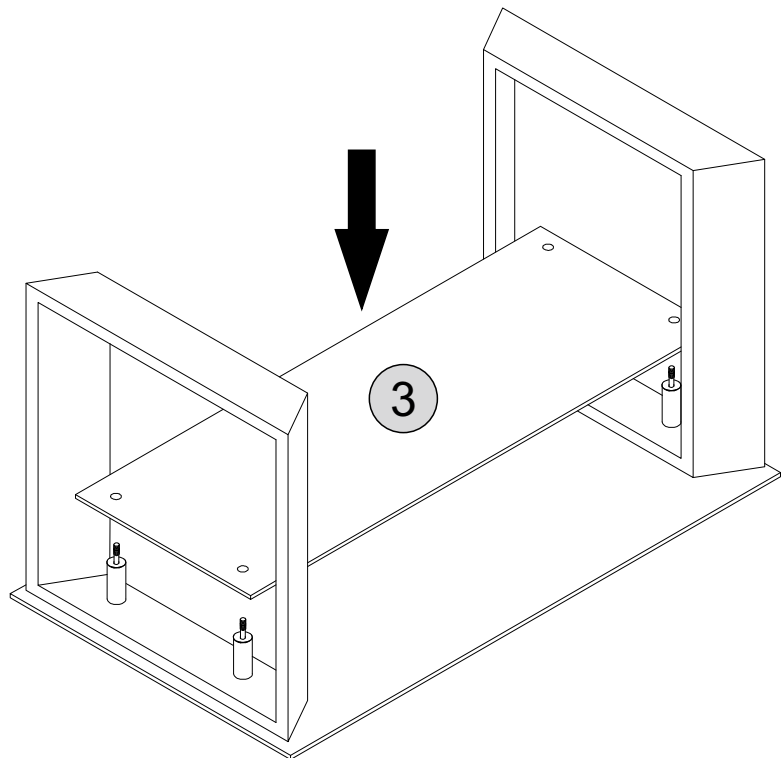

# STEP 5

**PARTS REQUIRED**

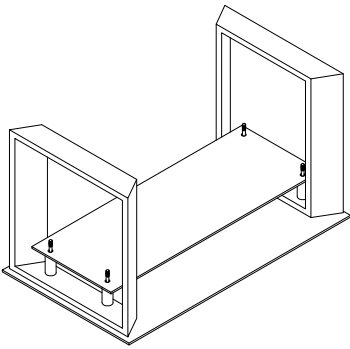

**HARDWARE REQUIRED**

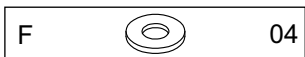

**TOOLS REQUIRED**

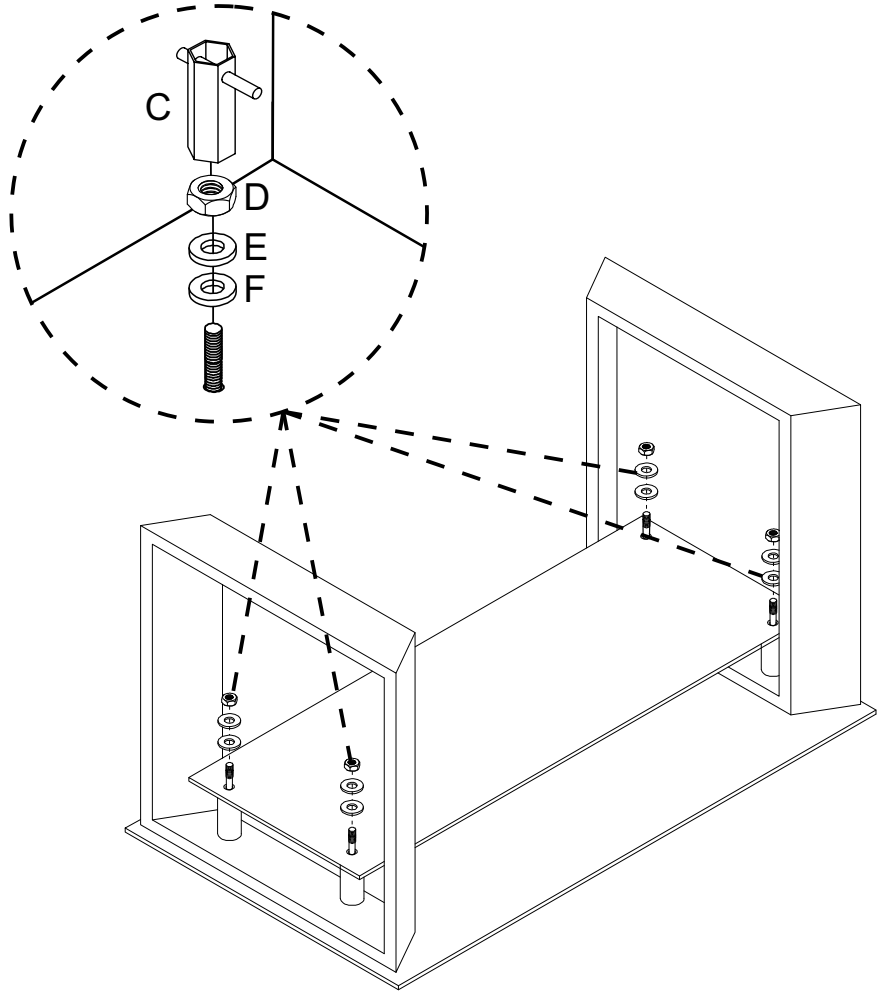
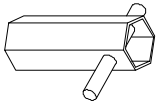

# STEP 6

**PARTS REQUIRED**

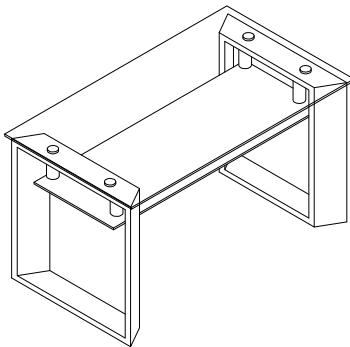

**HARDWARE REQUIRED**

**TOOLS REQUIRED**

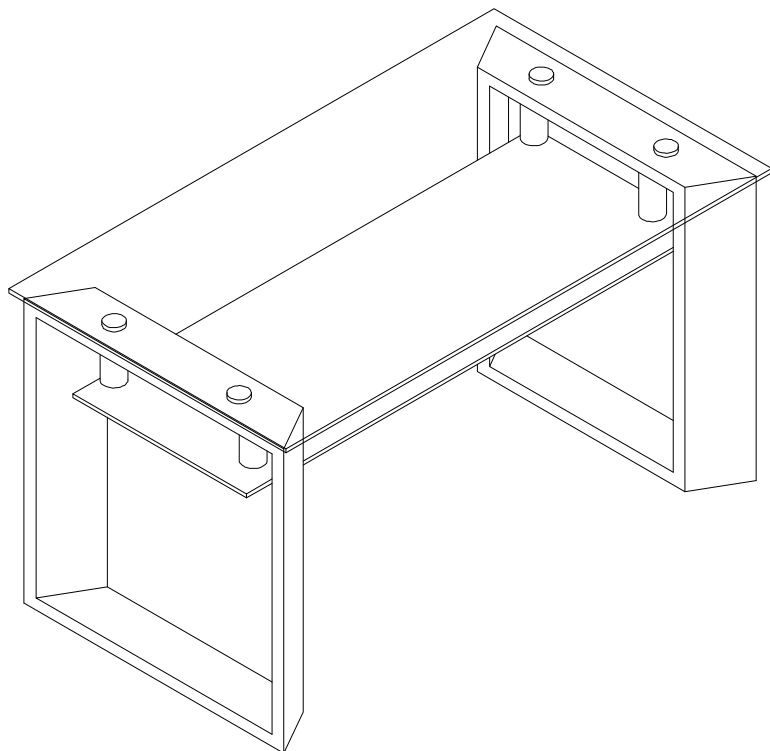

# BARLEY DINING CHAIR ASSEMBLY INSTRUCTIONS

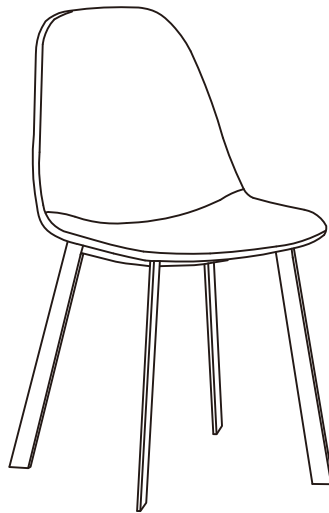

## IMPORTANT FOR DOMESTIC USE ONLY

### PLEASE READ BEFORE YOU CONTINUE FURTHER

THE PRODUCT YOU HAVE PURCHASED WILL GIVE YOU MANY YEARS OF SERVICE IF YOU FOLLOW THE GUIDELINES FOR ITS SAFE ASSEMBLY AND PERIODIC MAINTENANCE AND CLEANING .

ASSEMBLE ON A SOFT CLEAN SURFACE

DO NOT USE ANY TOOLS OTHER THAN THOSE SHOWN.

ANY SPANNERS OR ALLEN KEYS REQUIRED ARE INCLUDED WITH THE FITTINGS KIT.

DO NOT FOR ANY REASON USE A POWER TOOL TO ASSEMBLE THIS PRODUCT. ITS USE WILL INVALIDATE ANY CLAIM YOU MAY HAVE AND COULD MAKE THIS PRODUCT UNSAFE.

DEPENDING ON THE AMOUNT OF USE THIS PRODUCT RECEIVES IT MAY BE NECESSARY TO TIGHTEN UP THE FIXINGS FROM TIME TO TIME . THIS IS COMPLETELY NORMAL FOR ANY FLAT PACK FURNITURE.  
DO NOT OVERTIGHTEN FIXINGS.

FOR CLEANING, YOU MAY USE A DAMP CLOTH (NOT WET) DO NOT USE POLISH, DETERGENT OR CHEMICAL CLEANERS.

THIS PRODUCT MAY STAIN OR MARK IF ALLOWED TO COME INTO CONTACT WITH WET OR DAMP OBJECTS.

THE SURFACE OF THIS ITEM IS NOT HEAT RESISTANT. ALWAYS USE A PLACE MAT UNDER HOT OR COLD ITEMS TO PREVENT MARKING.

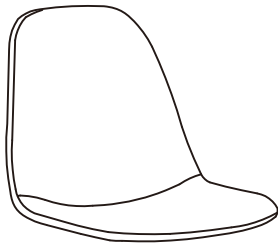

1

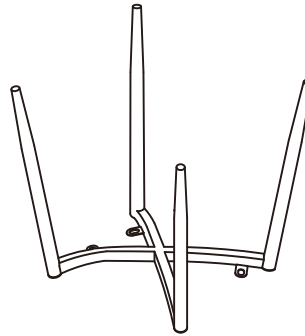



2

## **PARTS LIST**

<b>Part Number</b>	<b>Part Code</b>	<b>Part Description</b>	<b>Quantity</b>	<b>Carton</b>
1	S400-402-108-SF1-01	Chair Seat	1	1/1
2	S400-403-108-SF1-02	Chair Leg	1	1/1

## **HARDWARE LIST**

REF	PART NAME		QTY
A		<b>Bolts M6x16mm</b>	4 PCS
B	 M6x16	<b>Metal Washer</b>	4 PCS
C	 M5	<b>Allan Key</b>	1 PC

**PLEASE CHECK THAT YOU HAVE ALL THE PARTS LISTED BEFORE YOU START ASSEMBLING. IF YOU DO FIND THAT SOMETHING IS MISSING, DO NOT CONTINUE ASSEMBLY. PLEASE CONTACT YOUR SUPPLIER IMMEDIATELY.**



# STEP 1

## PARTS REQUIRED

1 - CHAIR SEAT x1

2 - CHAIR LEG x1

## HARDWARE REQUIRED

A  04

B  04

## TOOLS REQUIRED

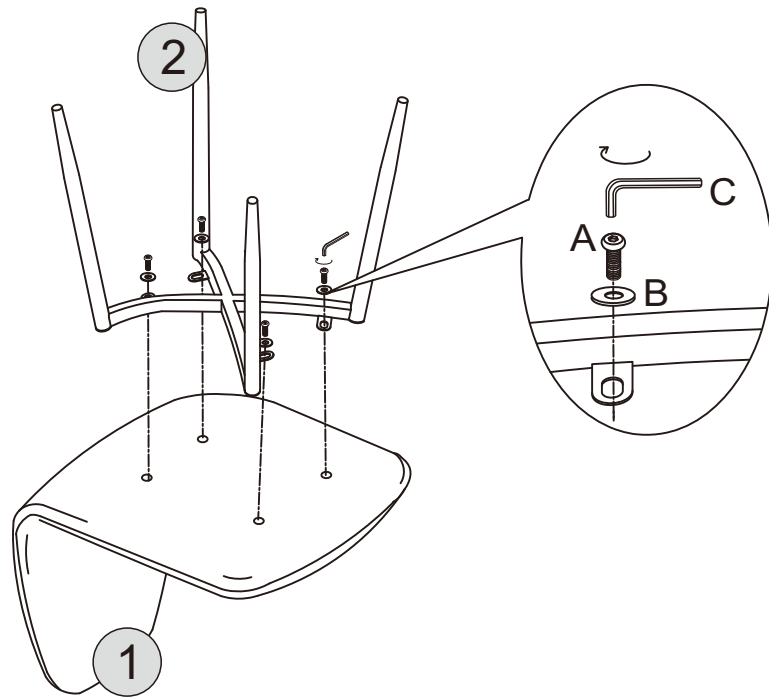

# STEP 2

## PARTS REQUIRED

## HARDWARE REQUIRED

## TOOLS REQUIRED

