

RIMINI DINING CHAIR ASSEMBLY INSTRUCTIONS



IMPORTANT

FOR DOMESTIC USE ONLY

PLEASE READ BEFORE YOU CONTINUE FURTHER

THE PRODUCT YOU HAVE PURCHASED WILL GIVE YOU MANY YEARS OF SERVICE IF YOU FOLLOW THE GUIDELINES FOR ITS SAFE ASSEMBLY AND PERIODIC MAINTENANCE AND CLEANING.

ASSEMBLE ON A SOFT CLEAN SURFACE.

DO NOT USE ANY TOOLS OTHER THAN THOSE SHOWN.

ANY SPANNERS OR ALLEN KEYS REQUIRED ARE INCLUDED WITH THE FITTINGS KIT.

DO NOT FOR ANY REASON USE A POWER TOOL TO ASSEMBLE THIS PRODUCT. ITS USE WILL INVALIDATE ANY CLAIM YOU MAY HAVE AND COULD MAKE THIS PRODUCT UNSAFE.

DEPENDING ON THE AMOUNT OF USE THIS PRODUCT RECEIVES IT MAY BE NECESSARY TO TIGHTEN UP THE FIXINGS FROM TIME TO TIME.

THIS IS COMPLETELY NORMAL FOR ANY FLAT PACK FURNITURE.

DO NOT OVERTIGHTEN FIXINGS.

FOR CLEANING, YOU MAY USE A DAMP CLOTH (NOT WET). DO NOT USE POLISH, DETERGENT OR CHEMICAL CLEANERS.

THE SURFACE OF THIS ITEM IS NOT HEAT RESISTANT. ALWAYS USE A PLACE MAT UNDER HOT OR COLD ITEMS TO PREVENT MARKING.

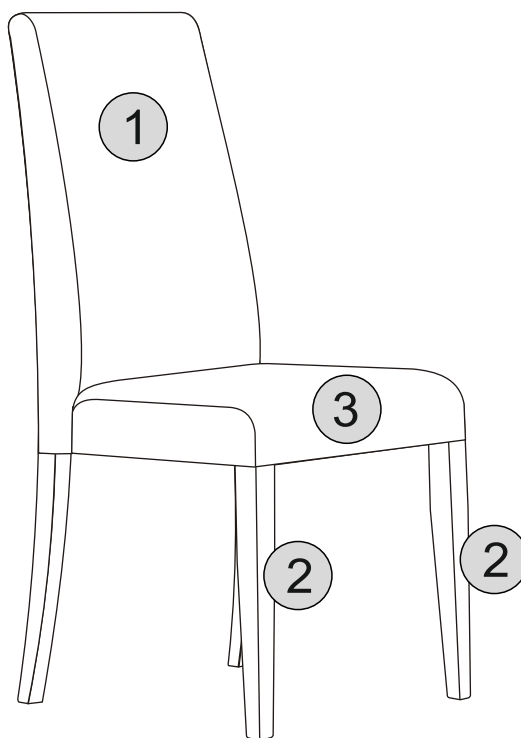

PARTS LIST

Part Number	Part Code	Part Description	Quantity	Carton
1	S400-402-081-PU1-01	Chair Back	1	1/1
2	S400-402-081-PU1-02	Front Leg	2	1/1
3	S400-402-081-PU1-03	Cushion Seat	1	1/1

HARDWARE LIST

REF		HARDWARE NAME	QTY
A		JCBC BOLTS (M70)	4PCS
B		JCBC BOLTS (M50)	4PCS
C		JCBC BOLTS (M40)	1PC
D		FLAT WASHER	9PCS
E		SPRING WASHER	9PCS
F		ALLEN KEY	1PC

PLEASE CHECK THAT YOU HAVE ALL THE PARTS LISTED BEFORE YOU START ASSEMBLING. IF YOU DO FIND THAT SOMETHING IS MISSING, DO NOT CONTINUE ASSEMBLY. PLEASE CONTACT YOUR SUPPLIER IMMEDIATELY.

STEP 1

PARTS REQUIRED

2 - FRONT LEG x2

3 - CUSHION SEAT x1

HARDWARE REQUIRED

B  04

D  04

E  04

TOOLS REQUIRED

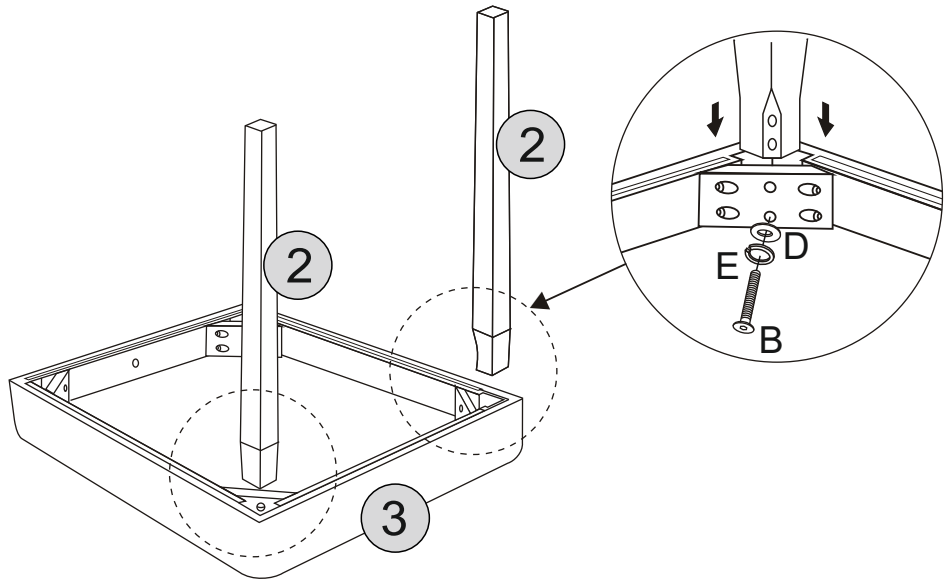

FULLY TIGHTEN ALL BOLTS !!

STEP 2

PARTS REQUIRED

1 - CHAIR BACK x1

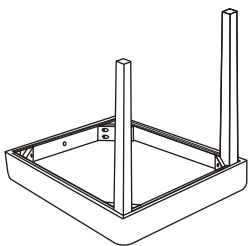

HARDWARE REQUIRED

C  01

D  01

E  01

TOOLS REQUIRED

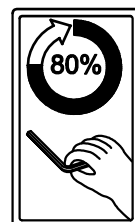
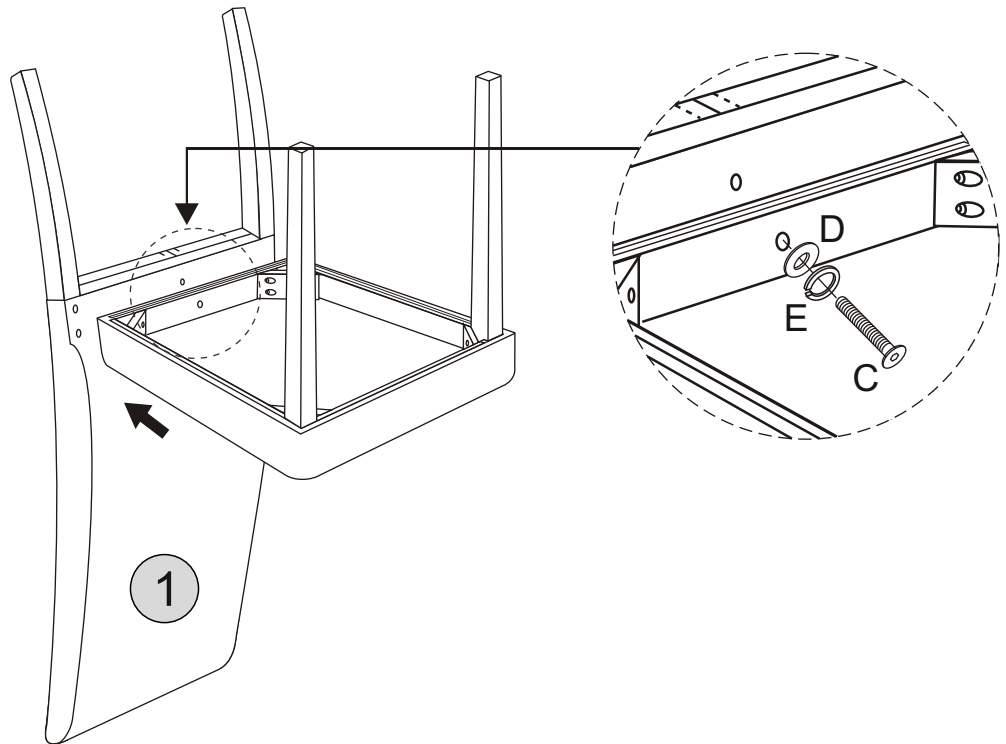

DO NOT FULLY TIGHTEN THE BOLTS AT THIS STAGE !!

STEP 3

PARTS REQUIRED



HARDWARE REQUIRED

A		04
D		04
E		04

TOOLS REQUIRED

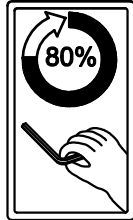
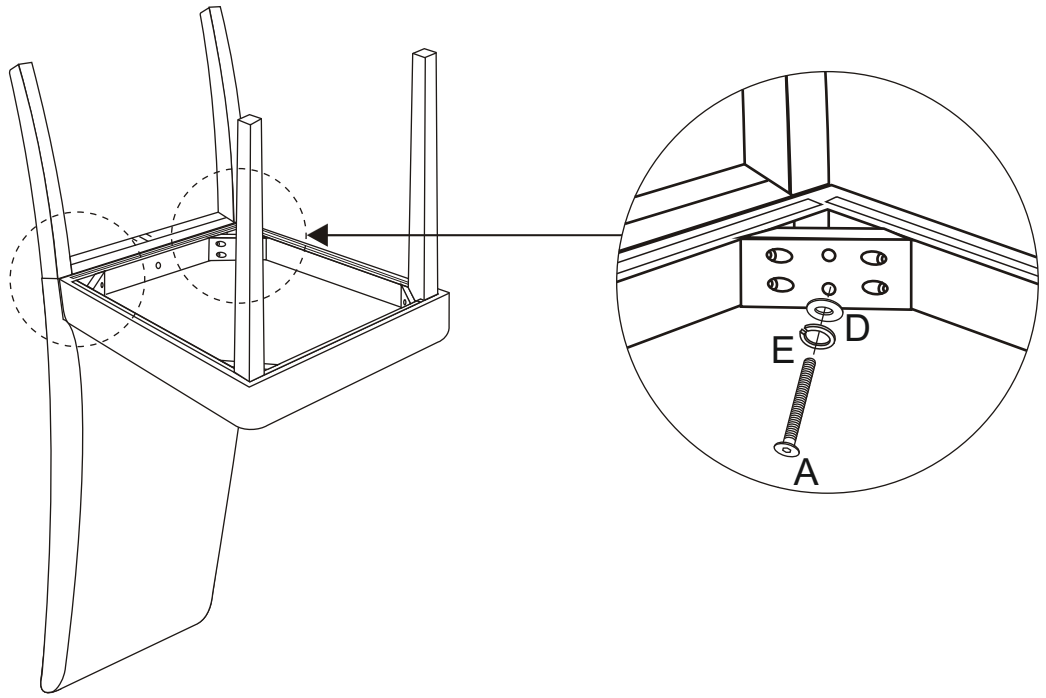
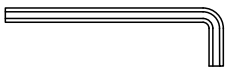

DO NOT FULLY TIGHTEN THE BOLTS AT THIS STAGE !!

STEP 4

PARTS REQUIRED

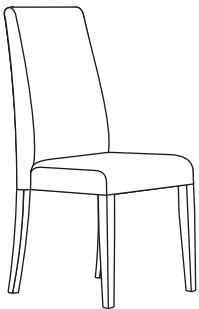

HARDWARE REQUIRED

TOOLS REQUIRED

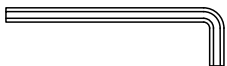

After all parts have been loosely bolted together, put the chair on the floor and make it level. Finally tighten all bolts carefully.

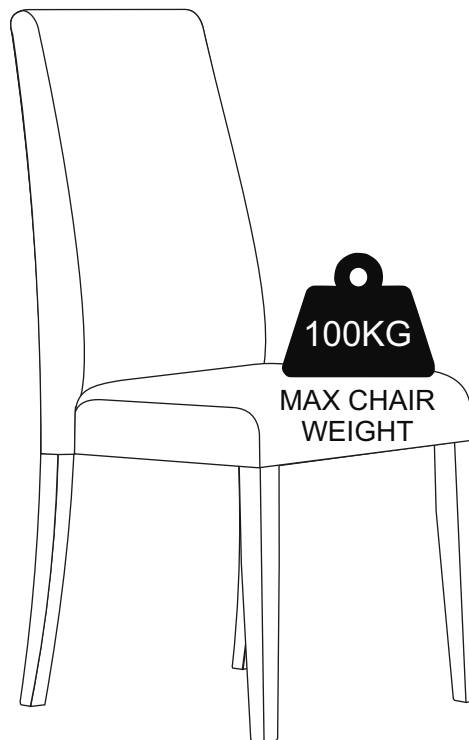

FULLY TIGHTEN ALL BOLTS !!