

LIGHT SONOMA OAK CHARISMA HOME BAR TABLE ASSEMBLY INSTRUCTIONS

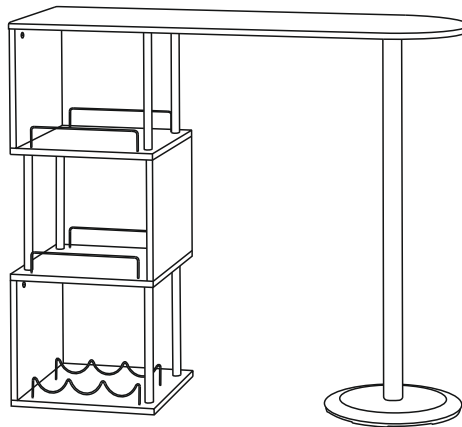

IMPORTANT PLEASE READ BEFORE YOU CONTINUE FURTHER FOR DOMESTIC USE ONLY

THE PRODUCT YOU HAVE PURCHASED WILL GIVE YOU MANY YEARS OF SERVICE IF YOU FOLLOW THE GUIDELINES FOR ITS SAFE ASSEMBLY AND PERIODIC MAINTENANCE AND CLEANING .

ASSEMBLE ON A SOFT CLEAN SURFACE

DO NOT USE ANY TOOLS OTHER THAN THOSE SHOWN.

ANY SPANNERS OR ALLEN KEYS REQUIRED ARE INCLUDED WITH THE FITTINGS KIT.

DO NOT FOR ANY REASON USE A POWER TOOL TO ASSEMBLE THIS PRODUCT. ITS USE WILL INVALIDATE ANY CLAIM YOU MAY HAVE AND COULD MAKE THIS PRODUCT UNSAFE.

DEPENDING ON THE AMOUNT OF USE THIS PRODUCT RECEIVES IT MAY BE NECESSARY TO TIGHTEN UP THE FIXINGS FROM TIME TO TIME . THIS IS COMPLETELY NORMAL FOR ANY FLAT PACK FURNITURE.
DO NOT OVERTIGHTEN FIXINGS.

FOR CLEANING, YOU MAY USE A DAMP CLOTH (NOT WET) DO NOT USE POLISH, DETERGENT OR CHEMICAL CLEANERS.

THIS PRODUCT MAY STAIN OR MARK IF ALLOWED TO COME INTO CONTACT WITH WET OR DAMP OBJECTS.

THE SURFACE OF THIS ITEM IS NOT HEAT RESISTANT. ALWAYS USE A PLACE MAT UNDER HOT OR COLD ITEMS TO PREVENT MARKING.

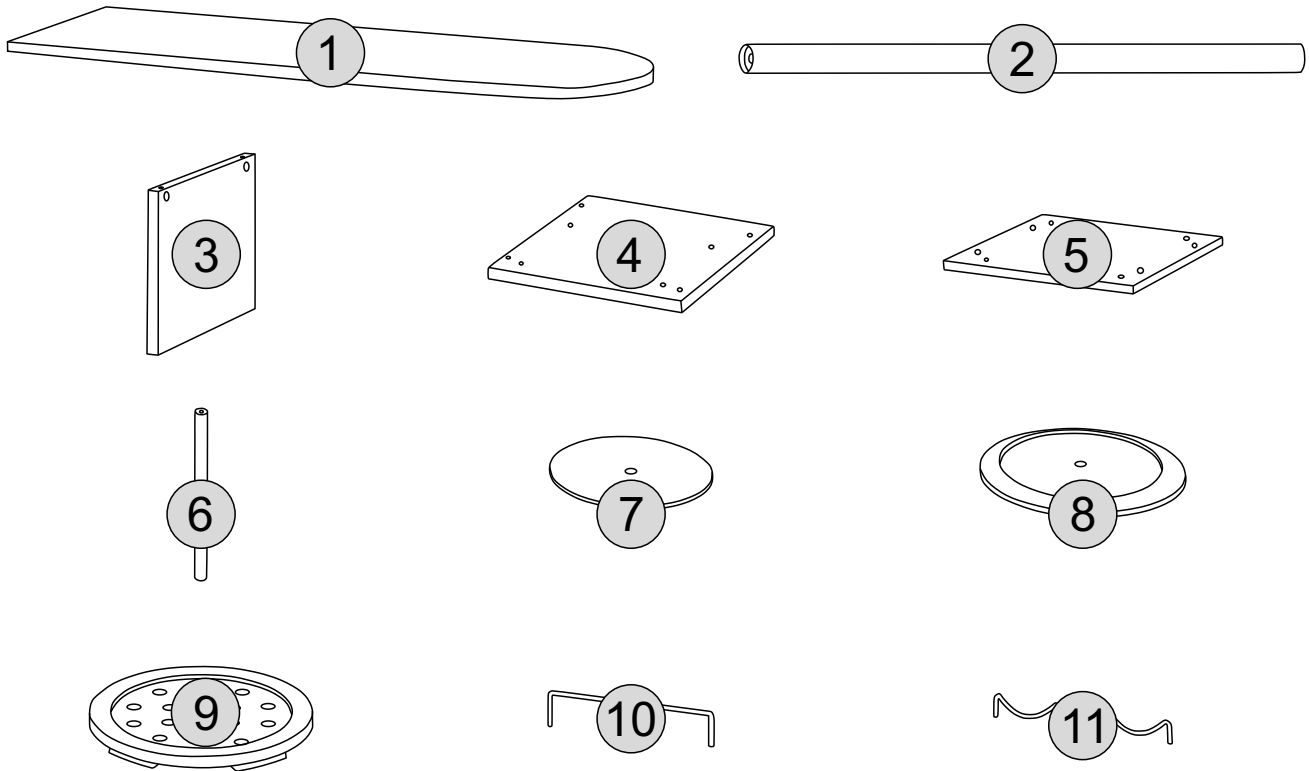













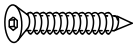

PARTS LIST

Part Number	Part Code	Part Description	Quantity	Carton
1	S400-403-054-MT1-01	Top Panel	1	1/1
2	S400-403-054-MT1-02	Large Metal Tube (51x990mm)	1	1/1
3	S400-403-054-MT1-03	Side Panel	3	1/1
4	S400-403-054-MT1-04	Bottom Panel	1	1/1
5	S400-403-054-MT1-05	Middle Panel	2	1/1
6	S400-403-054-MT1-06	Small Metal Tube (21x322mm)	6	1/1
7	S400-403-054-MT1-07	Tempered Glass	1	1/1
8	S400-403-054-MT1-08	Metal Base	1	1/1
9	S400-403-054-MT1-09	Counter Weight Block	1	1/1
10	S400-403-054-MT1-10	Straight Metal Wire	4	1/1
11	S400-403-054-MT1-11	Curved Metal Wire	2	1/1

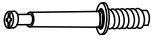
PLEASE CHECK THAT YOU HAVE ALL THE PARTS LISTED BEFORE YOU START ASSEMBLING. IF YOU DO FIND THAT SOMETHING IS MISSING, DO NOT CONTINUE ASSEMBLY. PLEASE CONTACT YOUR SUPPLIER IMMEDIATELY.

USE OF POWER TOOLS TO ASSEMBLE THIS PRODUCT WILL INVALIDATE ANY CLAIM AND MAY DAMAGE THIS PRODUCT MAKING IT UNSAFE.

HARDWARE LIST

REF		HARDWARE NAME	QTY
A		M8 Double Ended Studs	1PC
B		M6 Double Ended Studs	6PCS
C		M6 Wood Screw (Use M)	6PCS
D		M6 Bolt (Use M)	6PCS
E		M8 Bolt (Use L)	1PC
F		M8 Washer (38mm)	1PC
G		M8 Washer (28mm)	6PCS
H		Wooden Dowel	3PCS
I		Cam Bolt	6PCS
J		Cam Nut	6PCS
K		Foam Pad	4PCS
L		Large Allen Key	1PC
M		Small Allen Key	1PC
N		Screwdriver	1PC

TIPS FOR FITTINGS CAM-LOCKS

WHEN FITTING CAM NUT. ENSURE STARTING POSITION IS CORRECT BEFORE YOU INSERT CONNECTING CAM BOLT TURN CLOCKWISE UNTIL SECURE

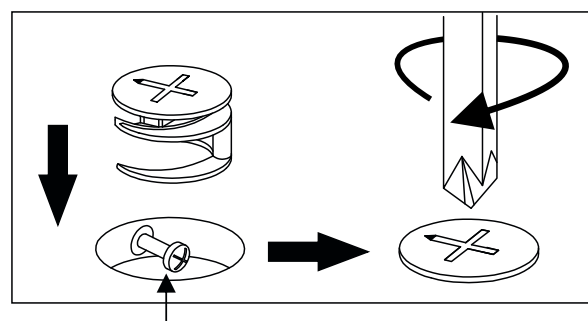
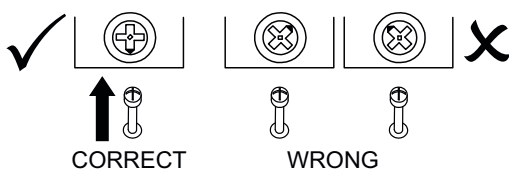

Cam bolt head needs to be in centre

CAMBOLT

Tighten until shoulder in flush with panel. Do not overtighten or undertighten (see example below)

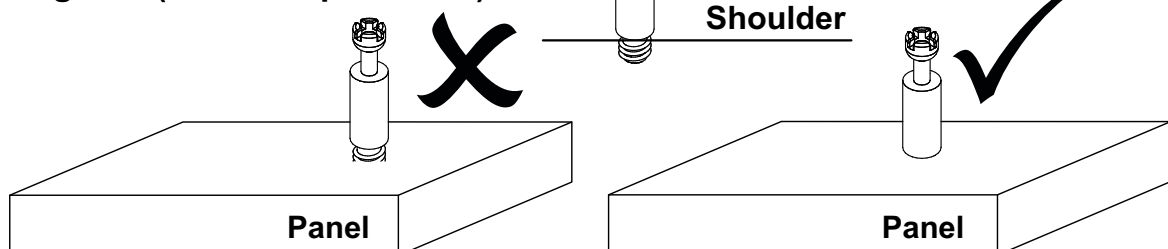

STEP 1

PARTS REQUIRED

1 - TOP PANEL x1

3 - SIDE PANEL x1

HARDWARE REQUIRED

H  01

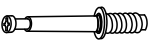
I  02

J  02

TOOLS REQUIRED

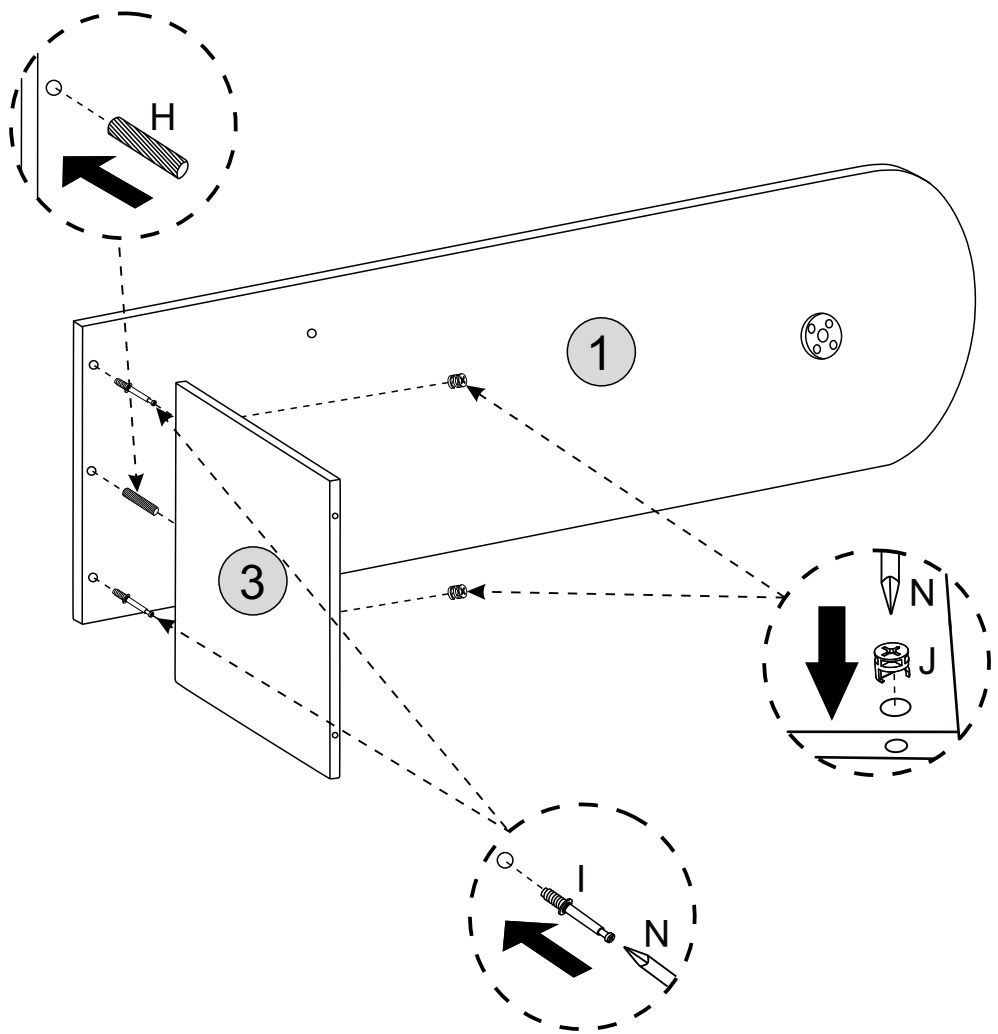
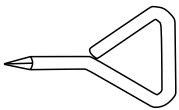

STEP 2

PARTS REQUIRED

5 - MIDDLE PANEL x1

6 - SMALL METAL TUBE x2

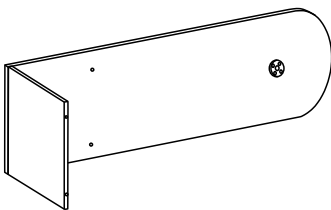

HARDWARE REQUIRED

B  02

C  02

D  02

G  02

TOOLS REQUIRED

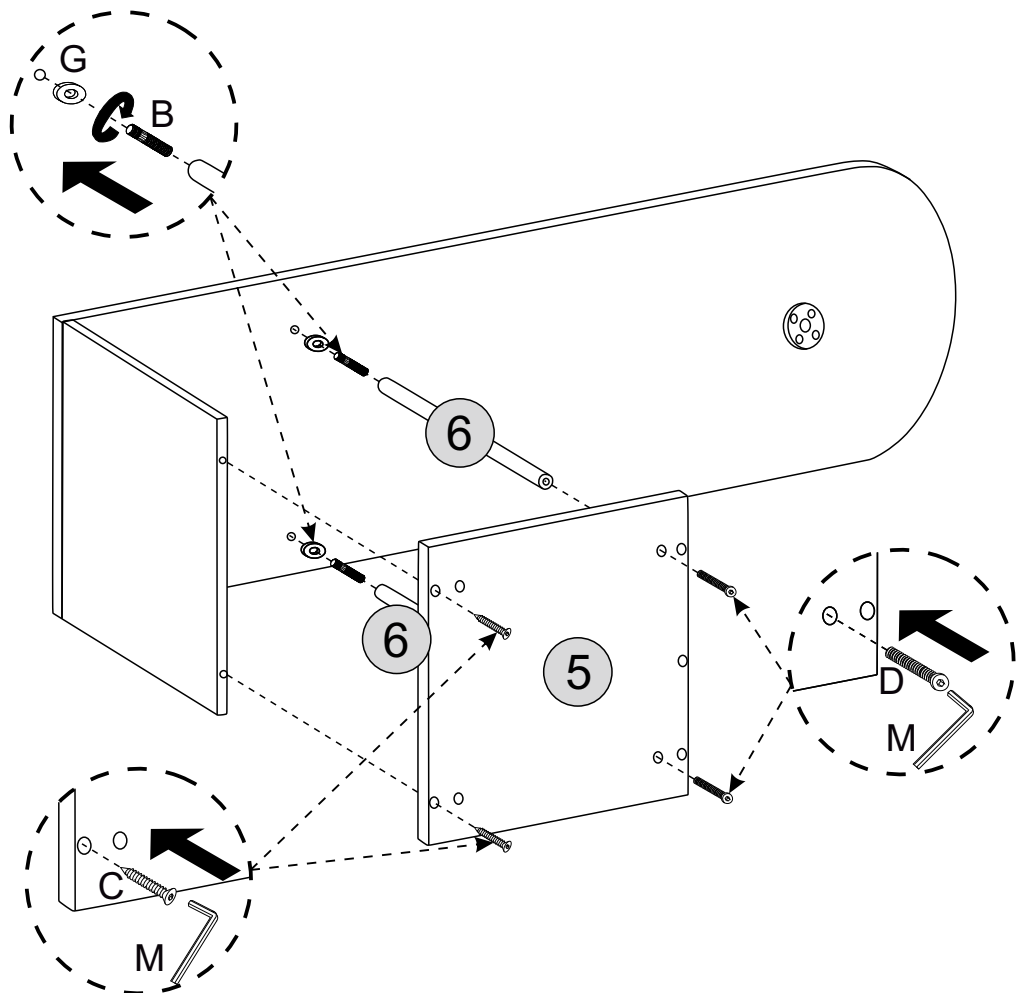

STEP 3

PARTS REQUIRED

3 - SIDE PANEL x1

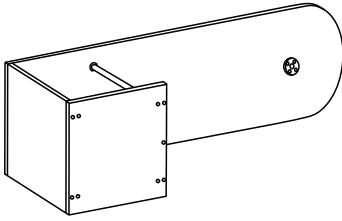

HARDWARE REQUIRED

H  01

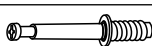
I  02

J  02

TOOLS REQUIRED

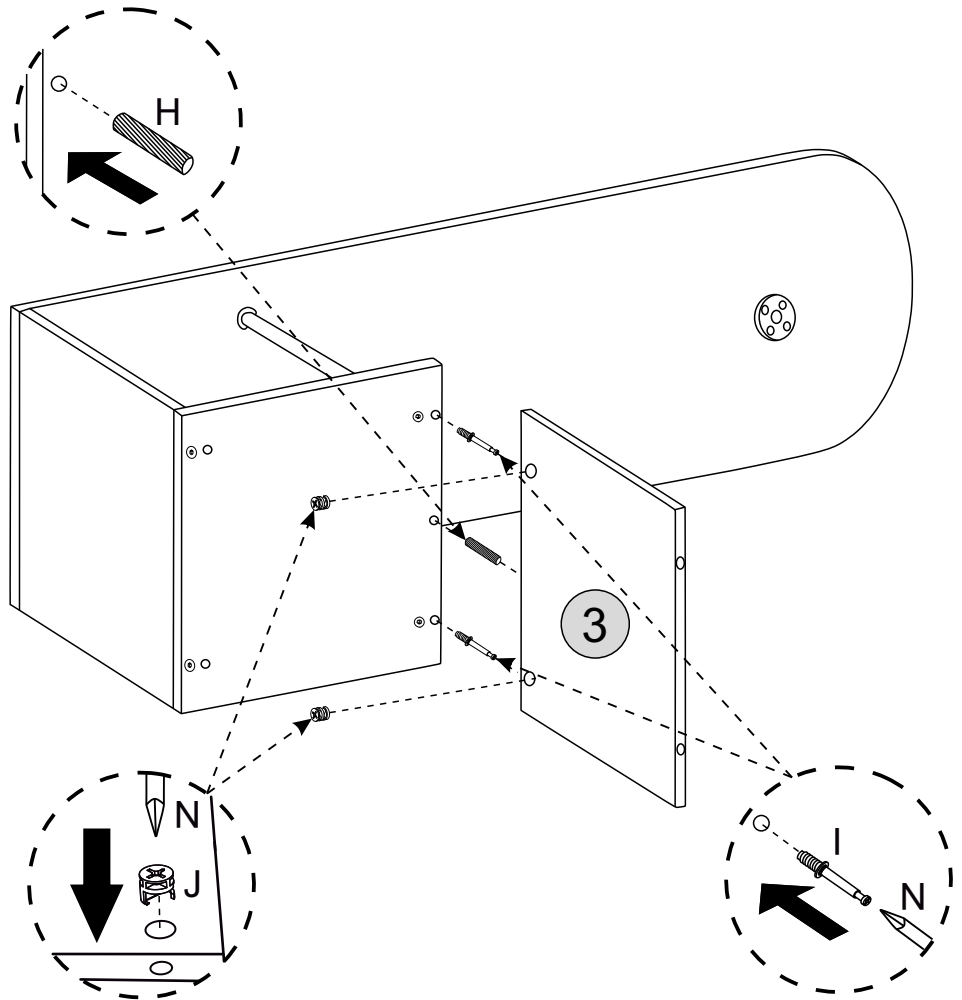
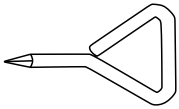

STEP 4

PARTS REQUIRED

5 - MIDDLE PANEL x1

6 - SMALL METAL TUBE x2

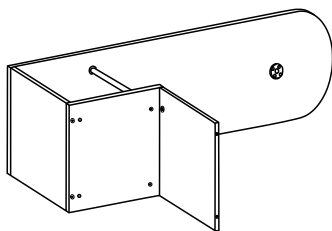

HARDWARE REQUIRED

B  02

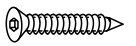
C  02

D  02

G  02

TOOLS REQUIRED

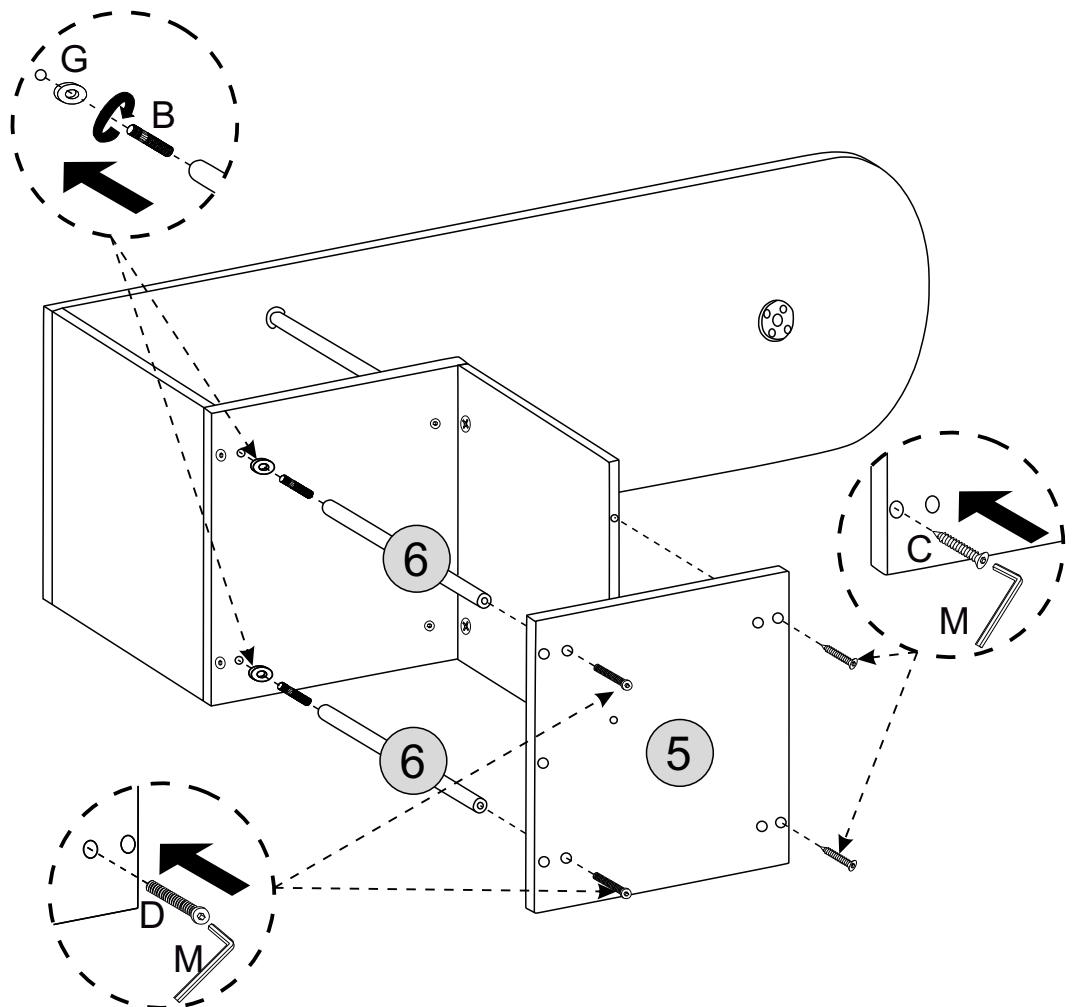

STEP 5

PARTS REQUIRED

3 - SIDE PANEL x1

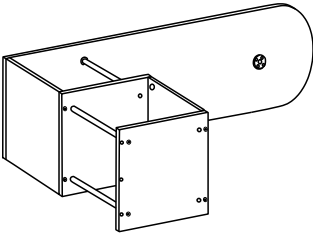

HARDWARE REQUIRED

H  01

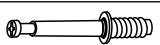
I  02

J  02

TOOLS REQUIRED

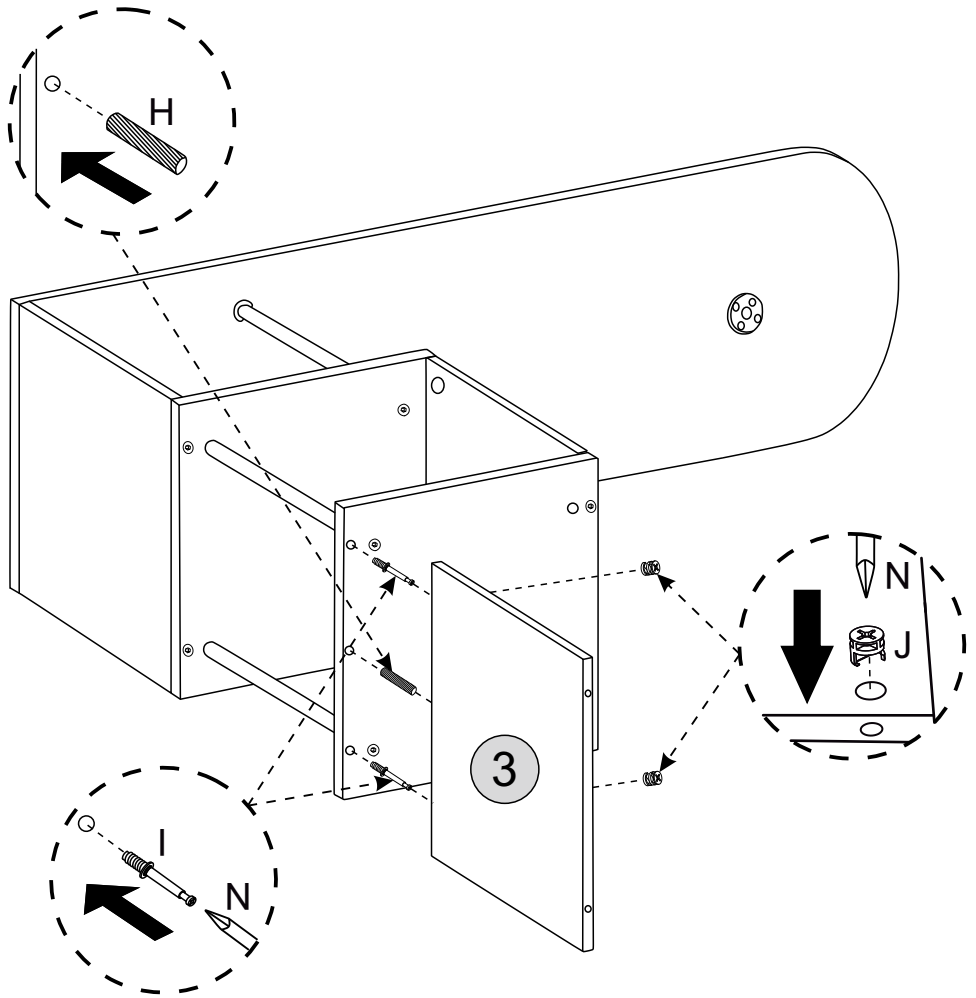
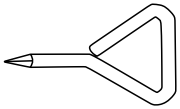

STEP 6

PARTS REQUIRED

4 - BOTTOM PANEL x1

6 - SMALL METAL TUBE x2

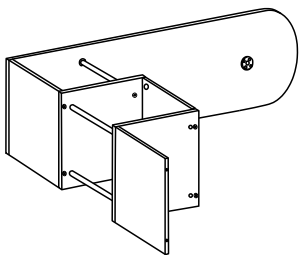

HARDWARE REQUIRED

B  02

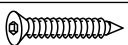
C  02

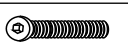
D  02

G  02

TOOLS REQUIRED

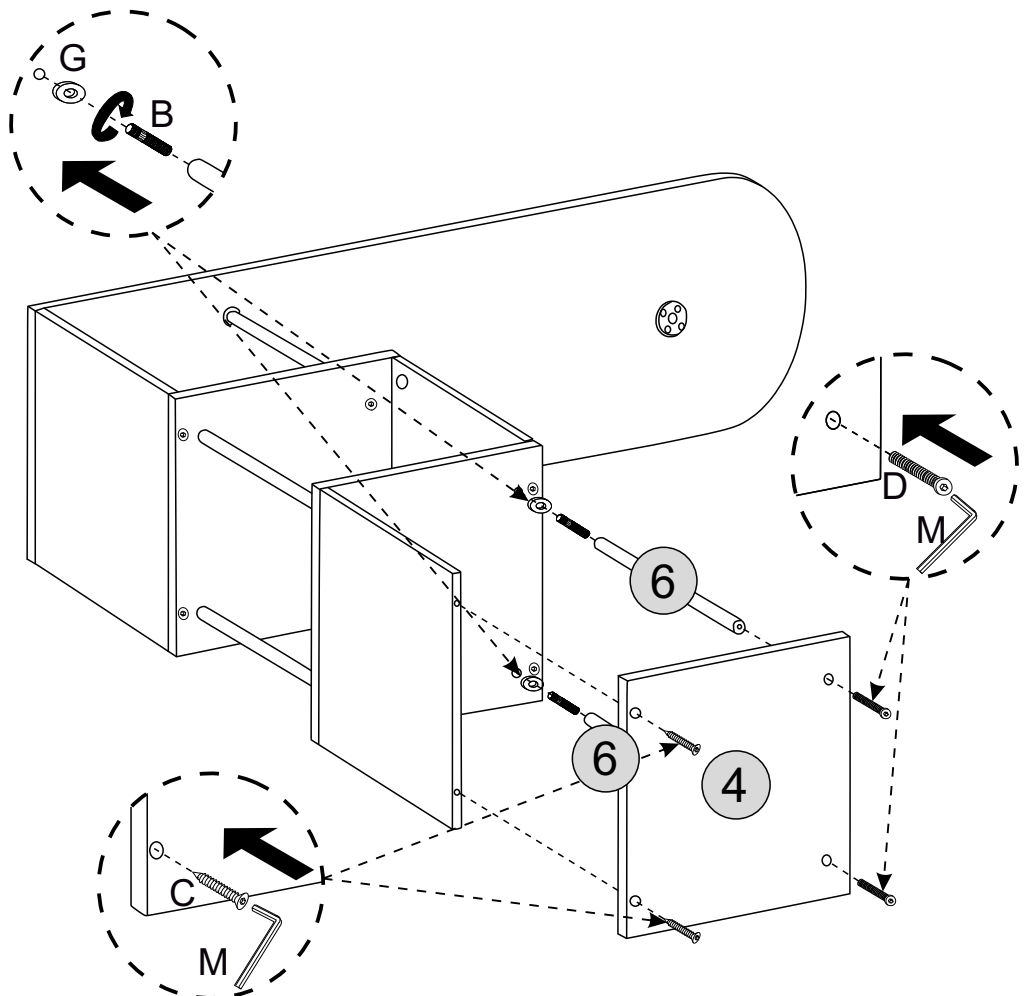

STEP 7

PARTS REQUIRED

2 - LARGE METAL TUBE x1

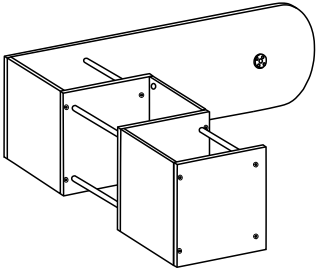

HARDWARE REQUIRED

A  01

TOOLS REQUIRED

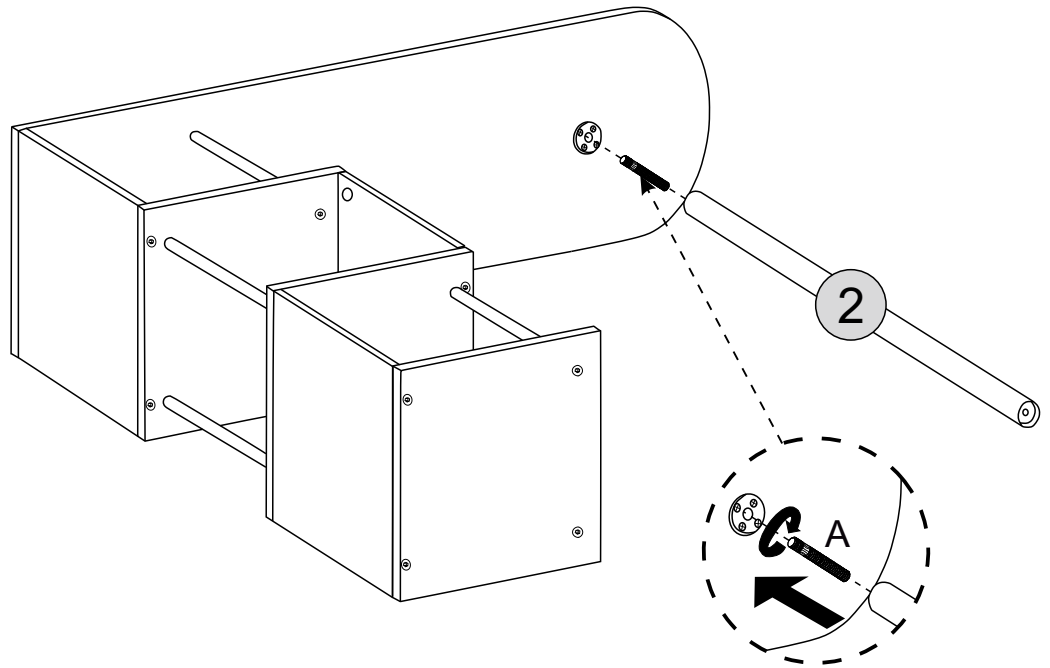

STEP 8

PARTS REQUIRED

7 - TEMPERED GLASS x1

8 - METAL BASE x1

9 - COUNTER WEIGHT BLOCK x1

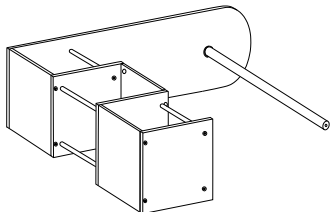

HARDWARE REQUIRED

E  01

F  01

K  04

TOOLS REQUIRED

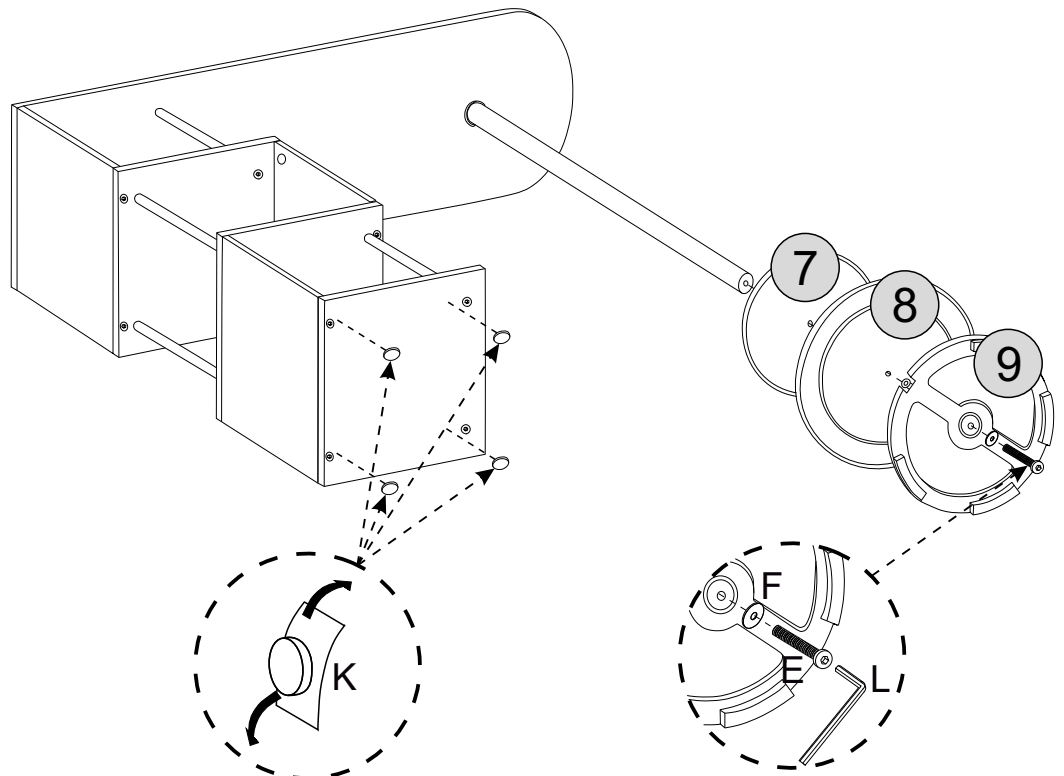

STEP 9

PARTS REQUIRED

10 - STRAIGHT METAL WIRE x4

11 - CURVED METAL WIRE x2

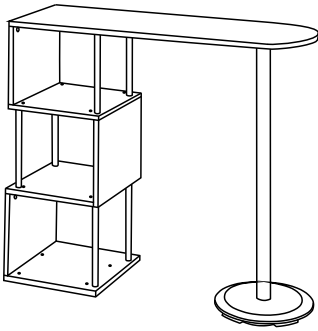

HARDWARE REQUIRED

TOOLS REQUIRED

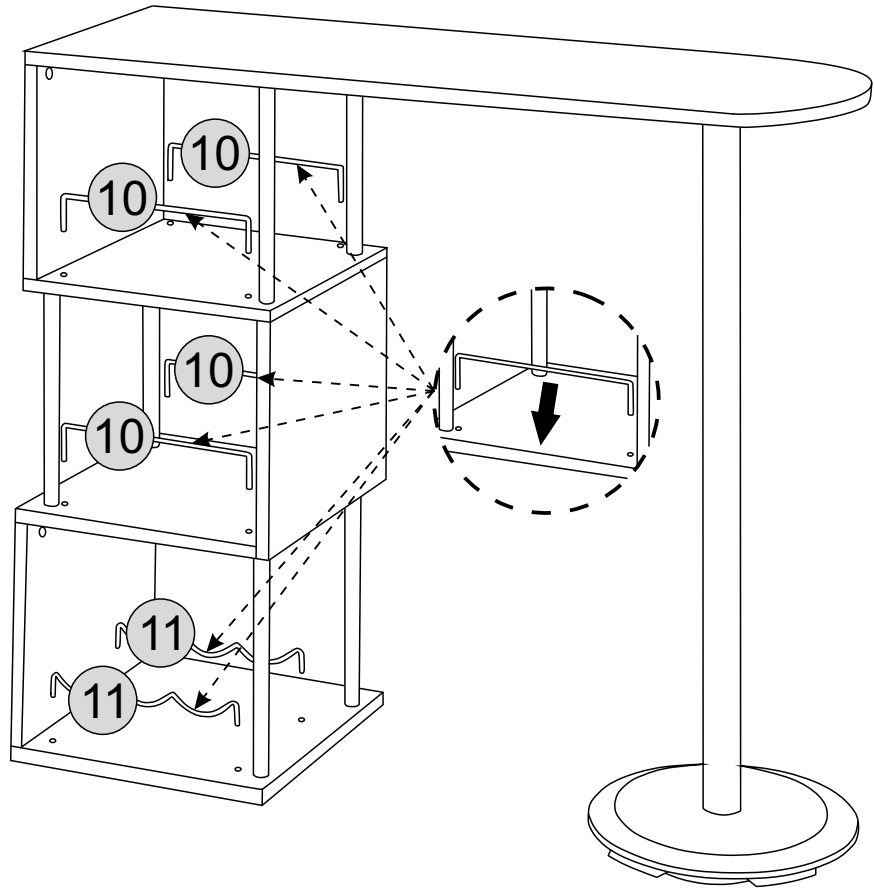

STEP 10

PARTS REQUIRED

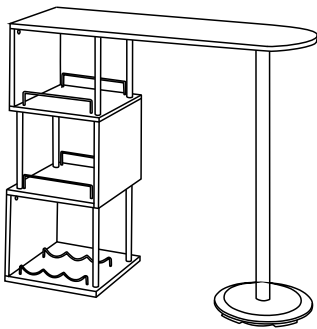

HARDWARE REQUIRED

TOOLS REQUIRED

