

CEDAR 4PC GARDEN SET

BLACK RATTAN/GREY FABRIC/BLACK GLASS

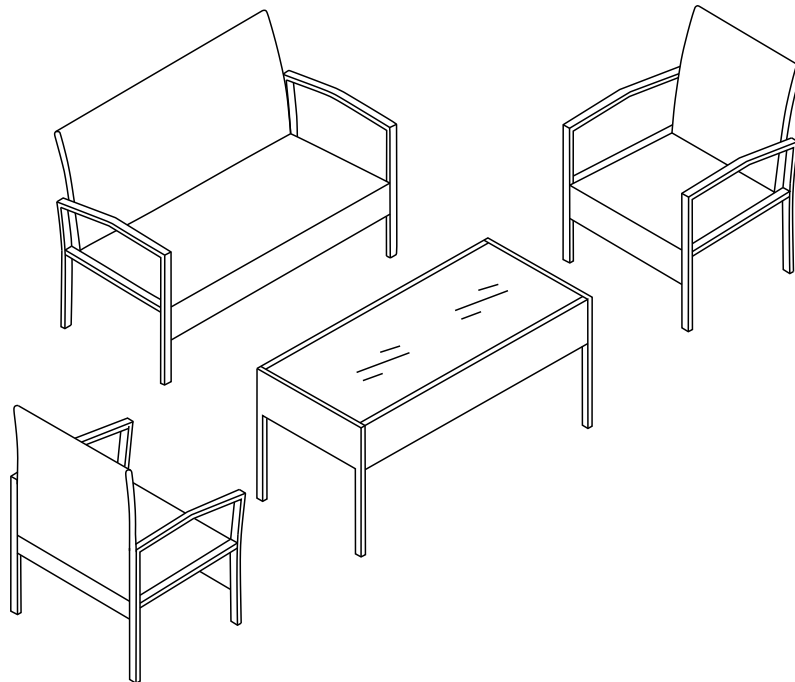

FOR DOMESTIC USE ONLY

IMPORTANT

PLEASE READ BEFORE YOU CONTINUE FURTHER

THE PRODUCTS YOU HAVE PURCHASED WILL GIVE YOU MANY YEARS OF SERVICE IF YOU FOLLOW THE GUIDELINES FOR ITS SAFE ASSEMBLY AND PERIODIC MAINTENANCE AND CLEANING.

ASSEMBLE ON A SOFT CLEAN SURFACE.

DO NOT USE ANY TOOLS OTHER THAN THOSE SHOWN.

ANY SPANNERS AND ALLEN KEYS REQUIRED ARE INCLUDED WITH THE FITTINGS KIT.

DO NOT FOR ANY REASON USE POWER TOOLS TO ASSEMBLY THIS PRODUCT. ITS USE WILL INVALIDATE ANY CLAIM AND MAY DAMAGE THIS PRODUCT MAKING IT UNSAFE.

DEPENDING ON THE AMOUNT OF USE THIS PRODUCT RECEIVES IT MAY BE NECESSARY TO TIGHTEN UP THE FIXINGS FROM TIME TO TIME.

DO NOT OVERTIGHTEN FIXINGS.

FOR CLEANING, YOU MAY USE A DAMP CLOTH (NOT WET) DO NOT USE POLISH, DETERGENT OR CHEMICAL CLEANERS.

THE SURFACE OF THIS ITEM IS NOT HEAT RESISTANT. ALWAYS USE A PLACE MAT UNDER HOT OR COLD ITEMS TO PREVENT MARKING.

CEDAR TABLE

CARE AND MAINTENANCE INSTRUCTIONS

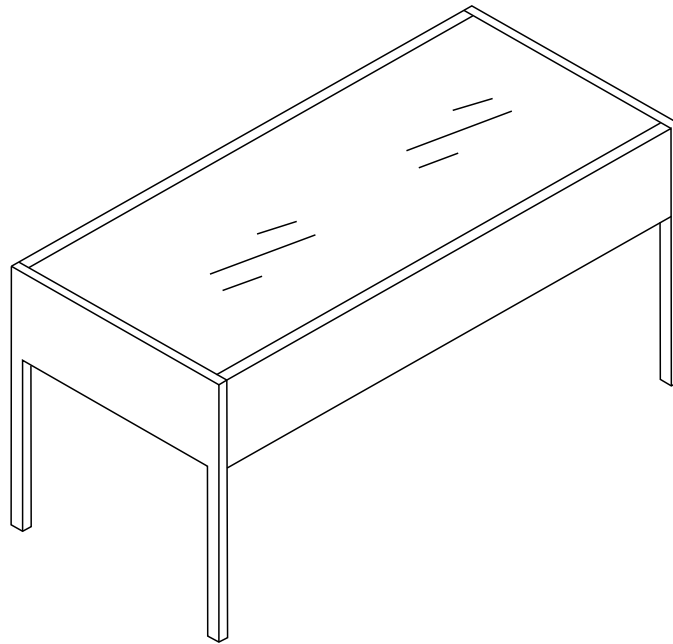

THIS PRODUCT INCLUDES TOUGHENED GLASS WITH A NOMINAL THICKNESS OF 5MM. IF THE GLASS IS CHIPPED OR BROKEN PLEASE REPLACE WITH TYPE DESCRIBED OR ALTERNATIVELY CONSULT WITH THE RETAILER STATING THE MODEL DETAILS.

WARNING

1. MAXIMUM LOAD ON TOP-DO NOT EXCEED 50KGS IN WEIGHT.
2. DO NOT SIT OR STAND ON GLASS SURFACES.
3. DO NOT USE GLASS AS CHOPPING SURFACE.
4. DO NOT STRIKE GLASS WITH HARD OR POINTED ITEMS.
5. DO NOT PLACE VERY HOT OR VERY COLD ITEMS ON THE GLASS SURFACE UNLESS ADEQUATELY THICK TABLE MATS ARE USED TO PREVENT SUCH ITEMS COMING INTO CONTACT WITH THE GLASS.
6. WHEN CLEANING GLASS PANELS USE A DAMP CLOTH OR LEATHER WITH WASHING UP LIQUID OR SOFT SOAP IF NECESSARY. DO NOT USE WASHING POWDER OR ANY OTHER SUBSTANCES CONTAINING ABRASIVES SINCE THESE SUBSTANTIALLY SCRATCH GLASS.
7. THE USE OF POWER TOOLS TO ASSEMBLE THIS PRODUCT WILL INVALIDATE ANY CLAIM AND MAY DAMAGE THIS PRODUCT MAKING IT UNSAFE

KEEP THESE INSTRUCTIONS IN A SAFE PLACE FOR FUTURE REFERENCE

THE GLASS USED IN THIS PRODUCT CONFORMS TO BS 7376:2004.

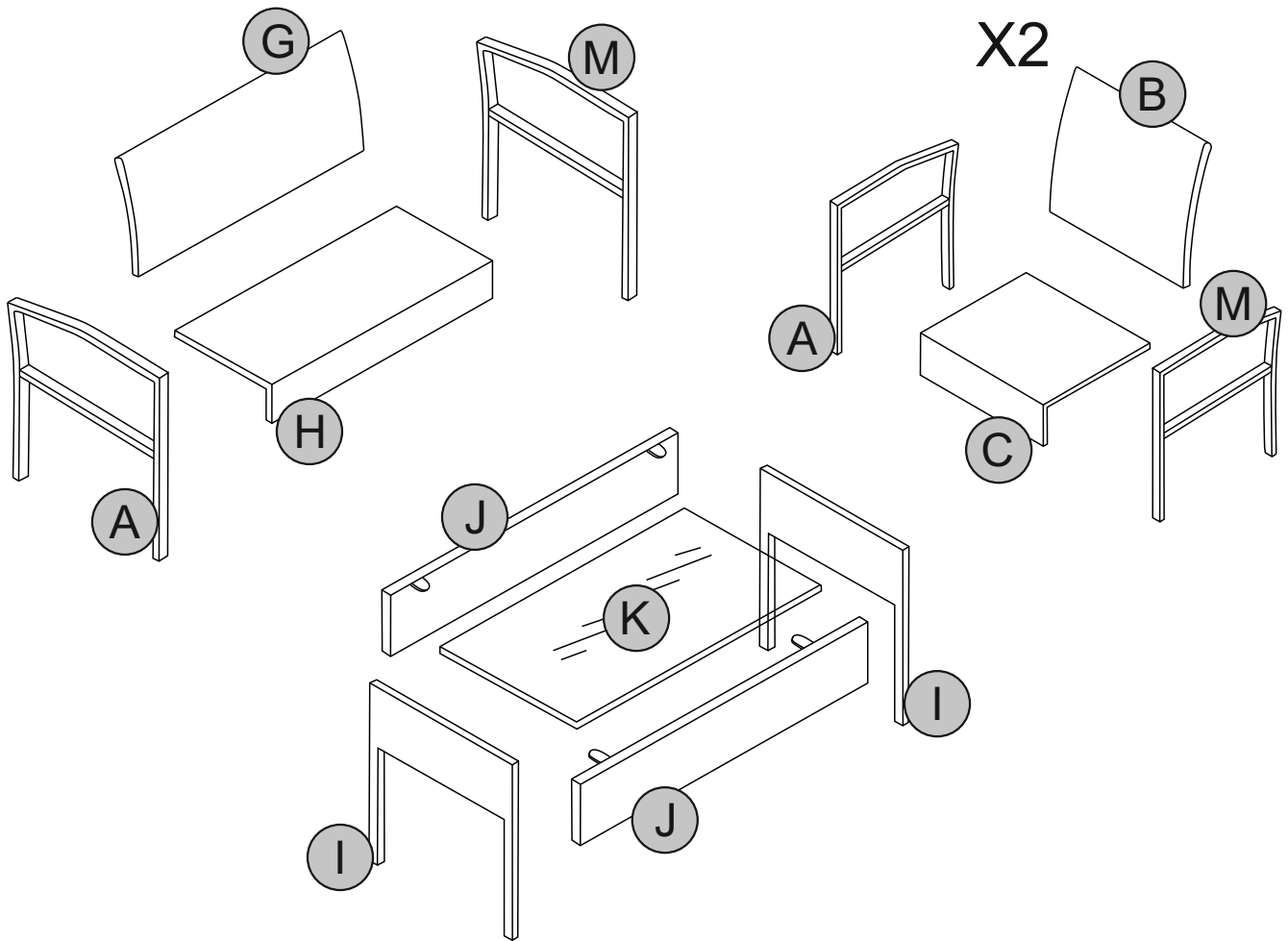

PLEASE CHECK THAT YOU HAVE ALL THE PARTS LISTED BEFORE YOU START ASSEMBLING. IF YOU DO FIND THAT SOMETHING IS MISSING, DO NOT CONTINUE ASSEMBLY. PLEASE CONTACT YOUR SUPPLIER IMMEDIATELY.

PARTS LIST

Part Number	Part Code	Part Description	Quantity	Carton
A	S700-701-004-XC1-A	Chair Frame (Left)	3	1
B	S700-701-004-XC1-B	Chair Back (Small)	2	1
C	S700-701-004-XC1-C	Seat Pad (Small)	2	1
G	S700-701-004-XC1-G	Chair Back (Large)	1	1
H	S700-701-004-XC1-H	Seat Pad (Large)	1	1
I	S700-701-004-XC1-I	Table Frame (Legs)	2	1
J	S700-701-004-XC1-J	Table Frame (Side)	2	1
K	S700-701-004-XC1-K	Table Top	1	1
M	S700-701-004-XC1-M	Chair Frame (Right)	3	1

HARDWARE LIST

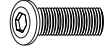
REF		HARDWARE NAME	QTY
P		Allen Key	1PC
Q		M6 x 35mm Bolt	45PCS
S		Suction Cup	4PCS

PLEASE CHECK THAT YOU HAVE ALL THE PARTS LISTED BEFORE YOU START ASSEMBLING. IF YOU DO FIND THAT SOMETHING IS MISSING, DO NOT CONTINUE ASSEMBLY. PLEASE CONTACT YOUR SUPPLIER IMMEDIATELY.

STEP 1

PARTS REQUIRED

B - CHAIR BACK (SMALL) x2

M- CHAIR FRAME (RIGHT) x2

HARDWARE REQUIRED

Q  04

TOOLS REQUIRED

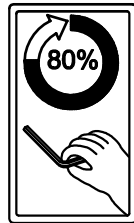
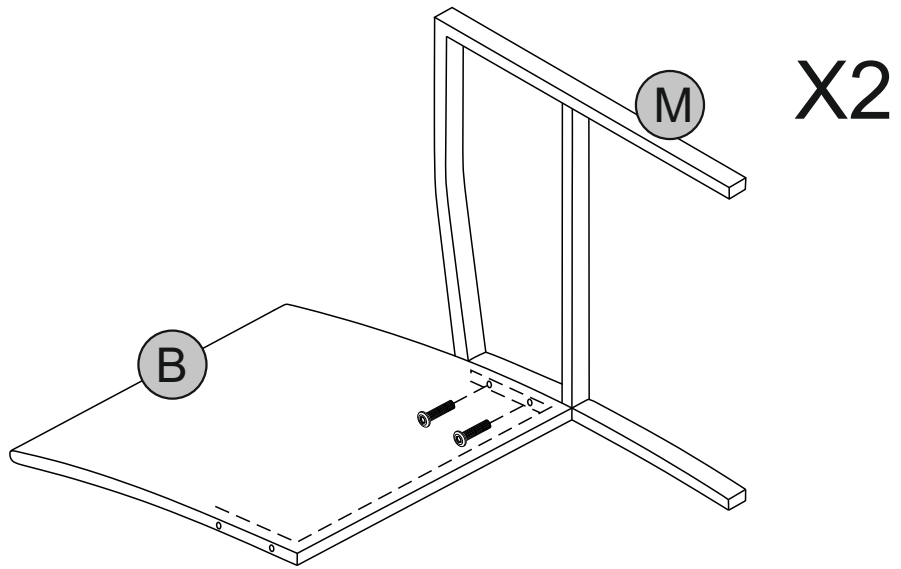

DO NOT FULLY TIGHTEN THE BOLTS AT THIS STAGE !!

STEP 2

PARTS REQUIRED

C - SEAT PAD (SMALL) x2

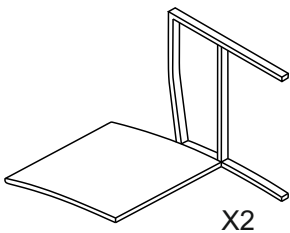

HARDWARE REQUIRED

Q  10

TOOLS REQUIRED

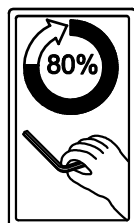
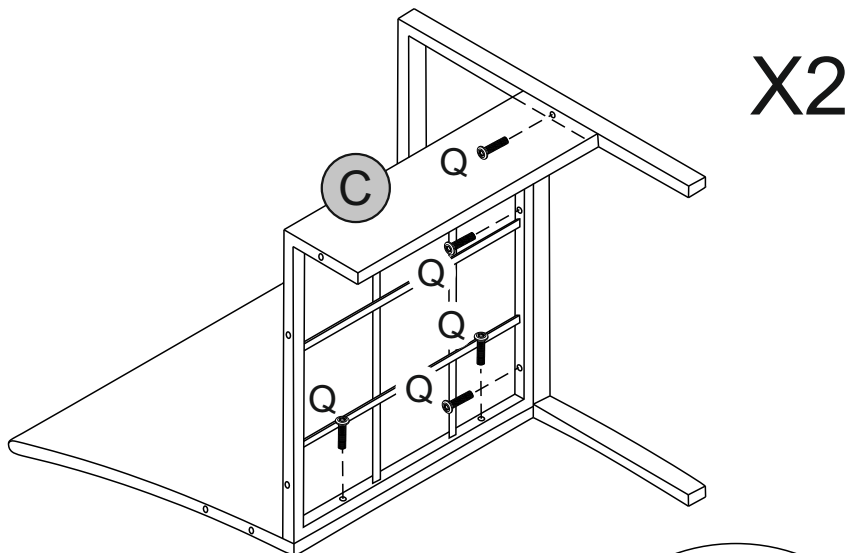

DO NOT FULLY TIGHTEN THE BOLTS AT THIS STAGE !!

STEP 3

PARTS REQUIRED

A - CHAIR FRAME (LEFT) x2

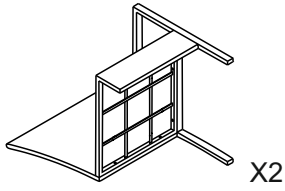

HARDWARE REQUIRED



TOOLS REQUIRED

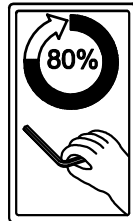
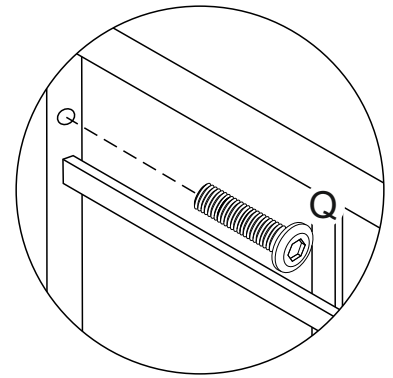
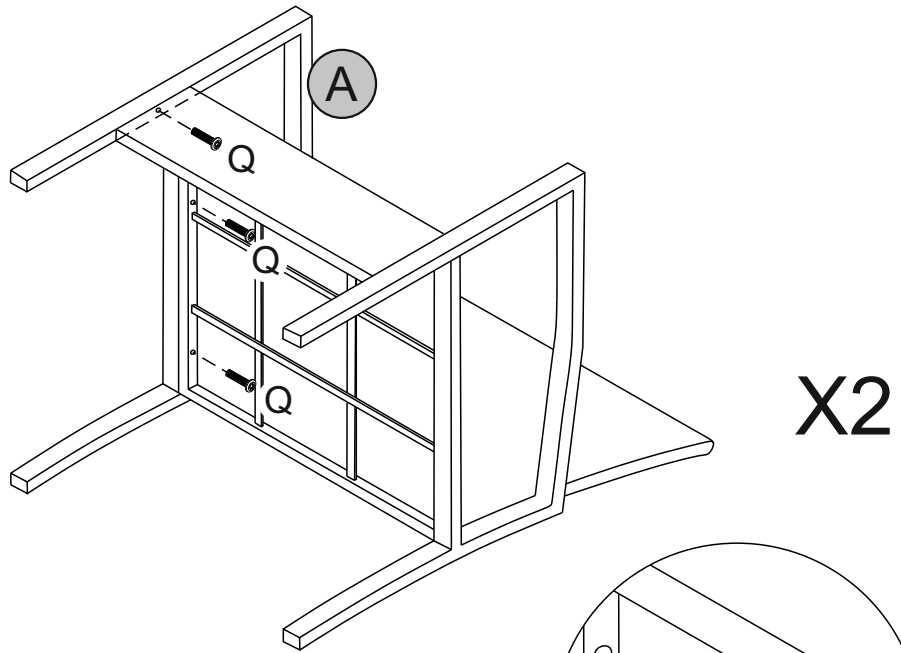

DO NOT FULLY TIGHTEN THE BOLTS AT THIS STAGE !!

STEP 4

PARTS REQUIRED

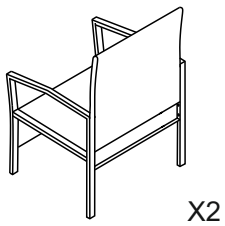

HARDWARE REQUIRED

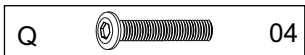

TOOLS REQUIRED

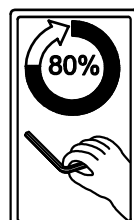
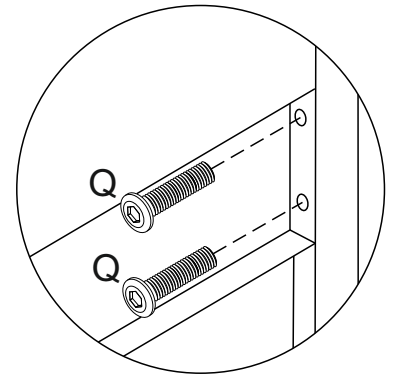
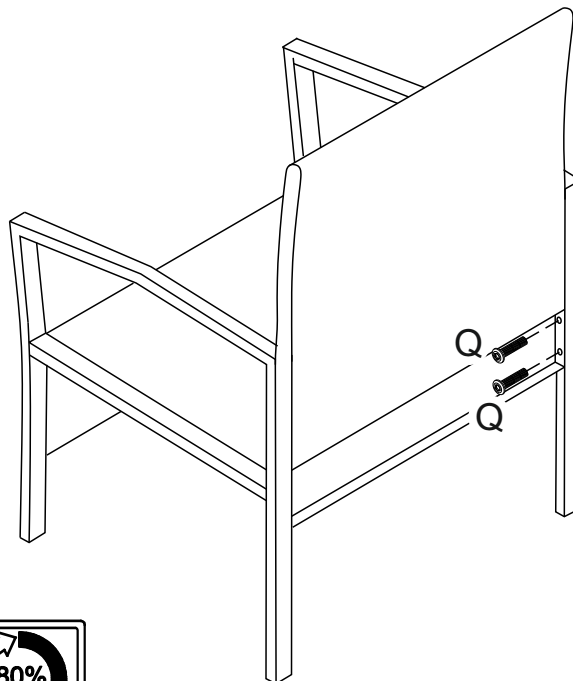

DO NOT FULLY TIGHTEN THE BOLTS AT THIS STAGE !!

STEP 5

PARTS REQUIRED

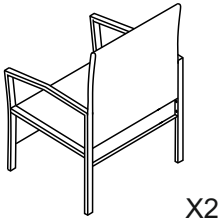

HARDWARE REQUIRED

TOOLS REQUIRED

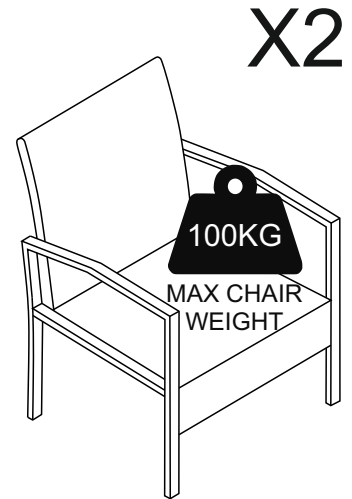
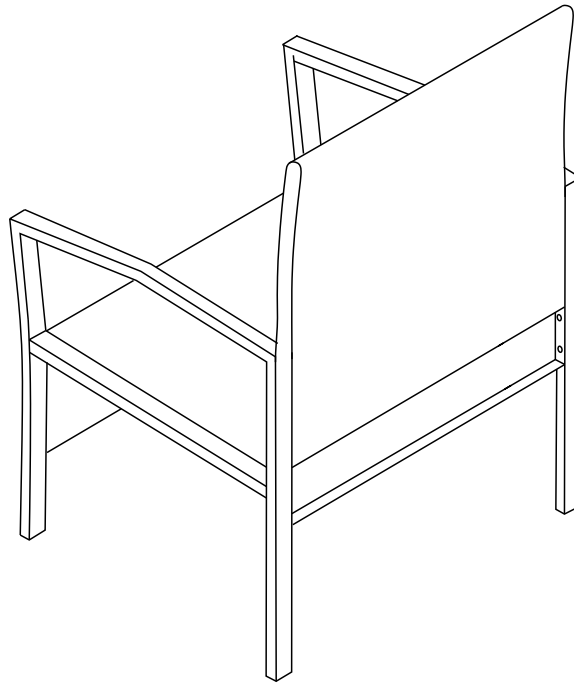

NOW FULLY TIGHTEN ALL THE BOLTS !!

STEP 6

PARTS REQUIRED

G- CHAIR BACK (LARGE) x1

M- CHAIR FRAME (RIGHT) x1

HARDWARE REQUIRED

Q  02

TOOLS REQUIRED

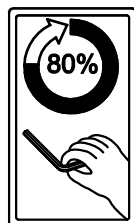
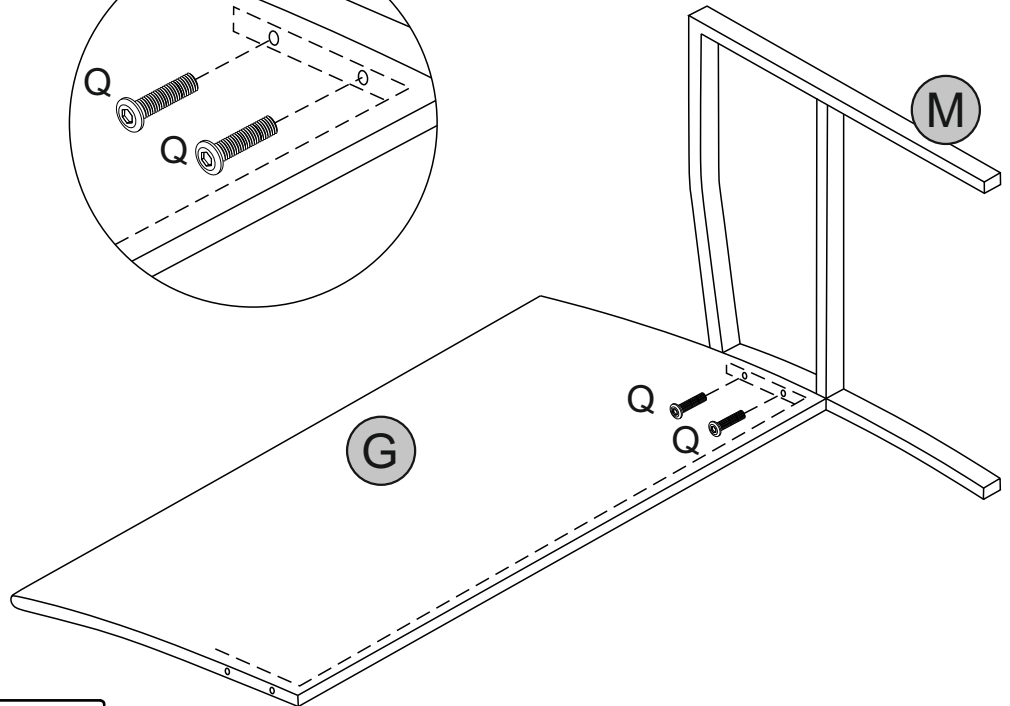
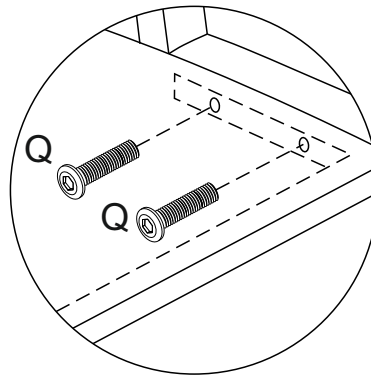
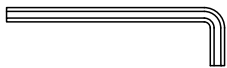

DO NOT FULLY TIGHTEN THE BOLTS AT THIS STAGE !!

STEP 7

PARTS REQUIRED

H - SEAT PAD (LARGE) x1

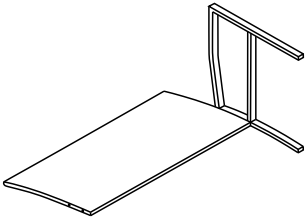

HARDWARE REQUIRED

Q  06

TOOLS REQUIRED

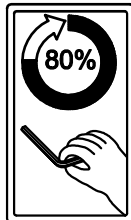
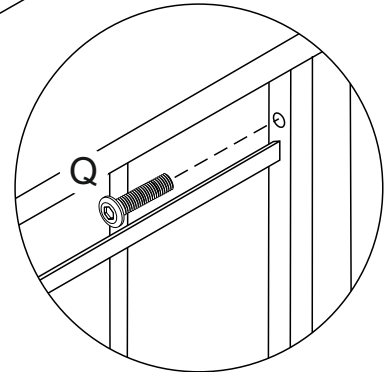
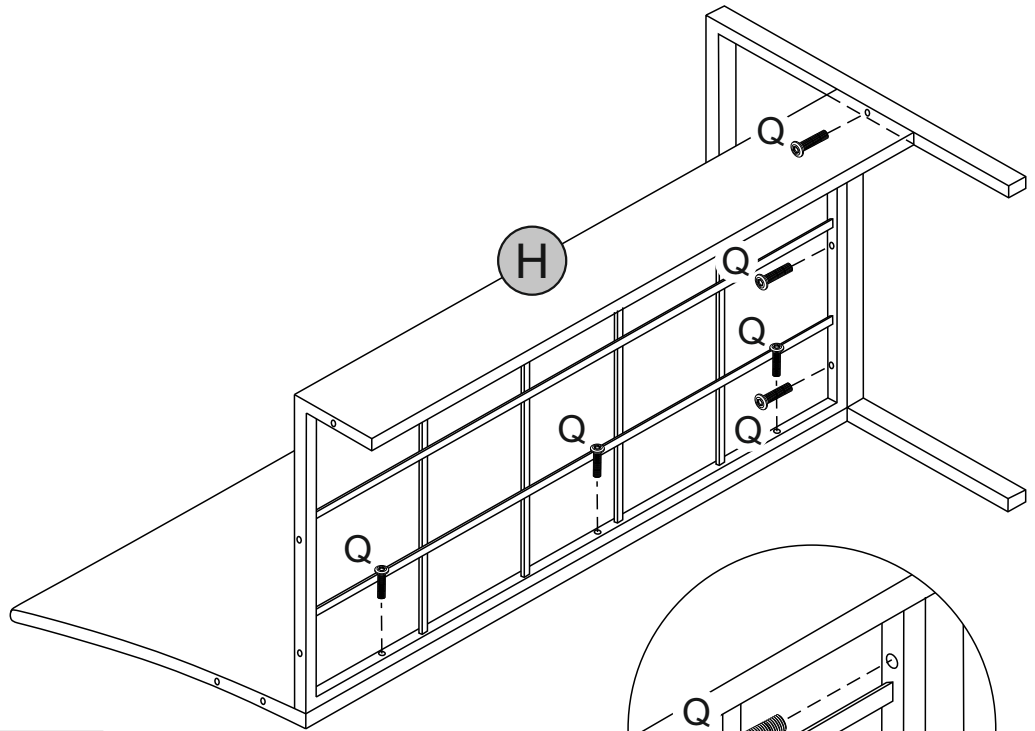

DO NOT FULLY TIGHTEN THE BOLTS AT THIS STAGE !!

STEP 8

PARTS REQUIRED

A - CHAIR FRAME (LEFT) x1

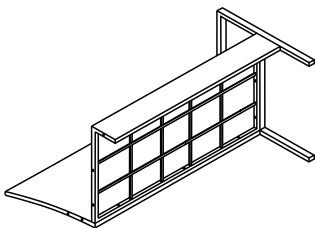

HARDWARE REQUIRED

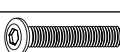
Q  03

TOOLS REQUIRED

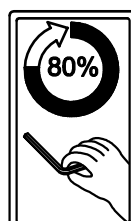
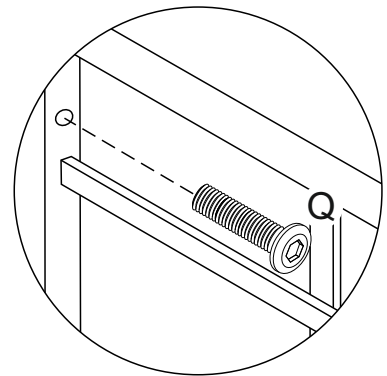
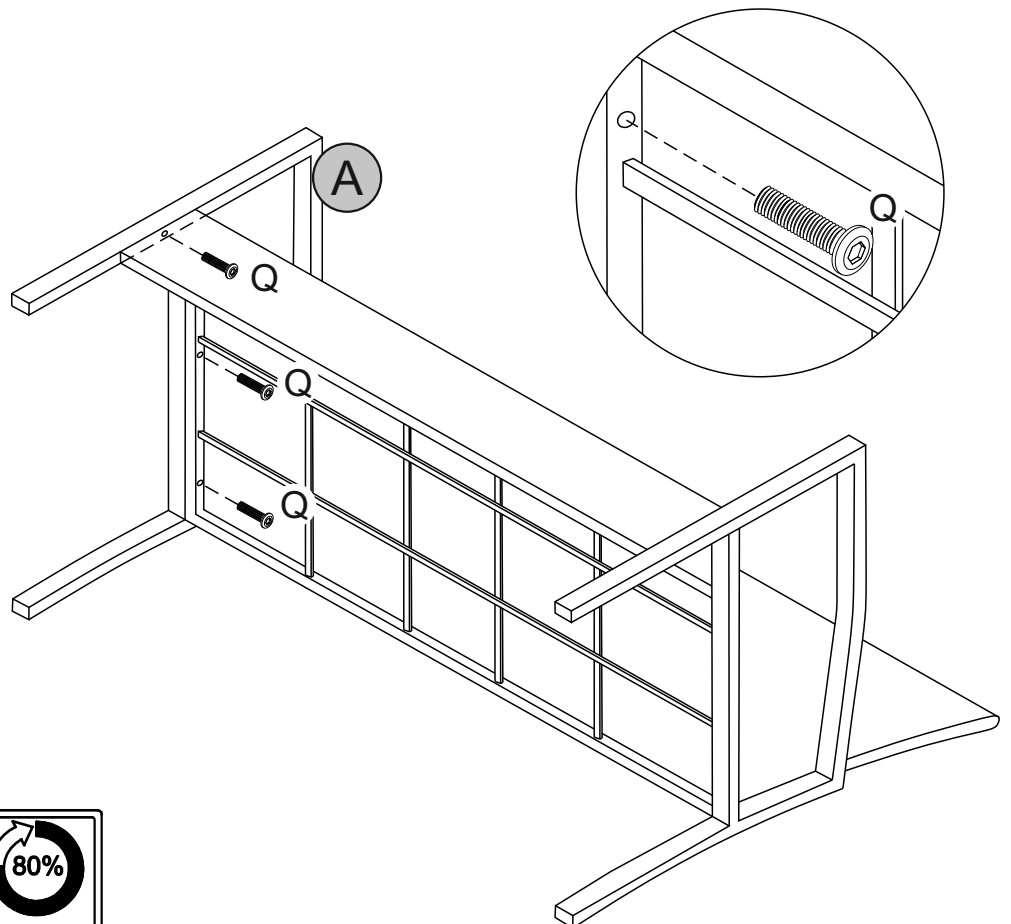

DO NOT FULLY TIGHTEN THE BOLTS AT THIS STAGE !!

STEP 9

PARTS REQUIRED

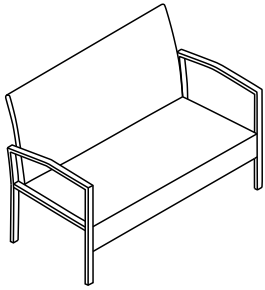

HARDWARE REQUIRED

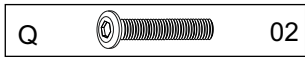

TOOLS REQUIRED

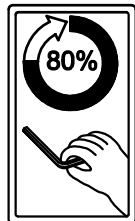
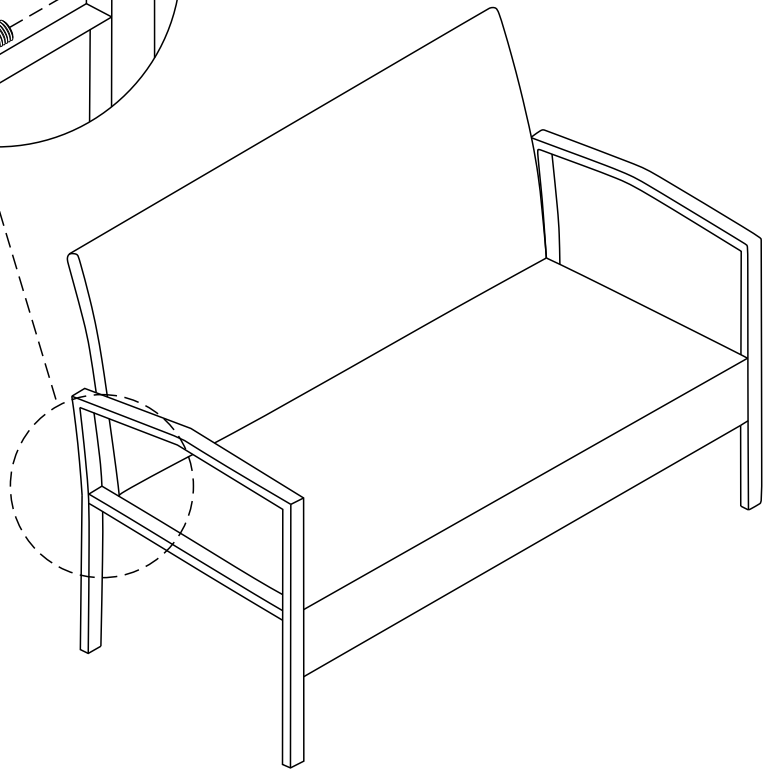
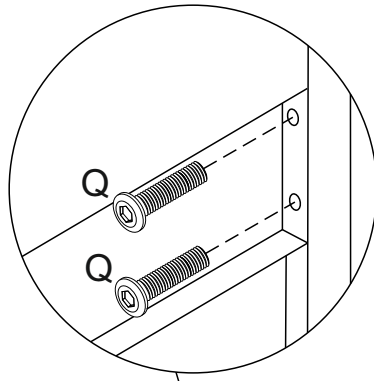

DO NOT FULLY TIGHTEN THE BOLTS AT THIS STAGE !!

STEP 10

PARTS REQUIRED

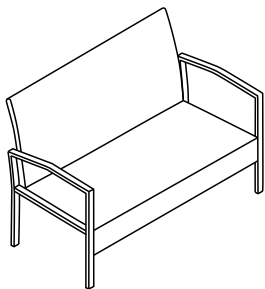

HARDWARE REQUIRED

TOOLS REQUIRED



MAX CHAIR WEIGHT

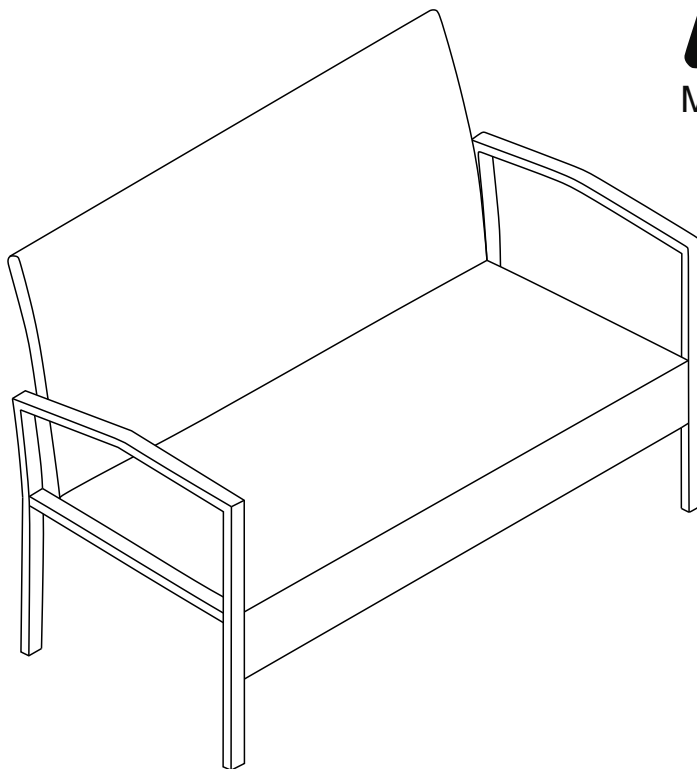

NOW FULLY TIGHTEN ALL THE BOLTS !!

STEP 11

PARTS REQUIRED

I - TABLE FRAME (LEGS) x1

J - TABLE FRAME (SIDE) x2

HARDWARE REQUIRED

Q  04

TOOLS REQUIRED

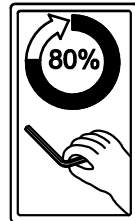

DO NOT FULLY TIGHTEN THE BOLTS AT THIS STAGE !!

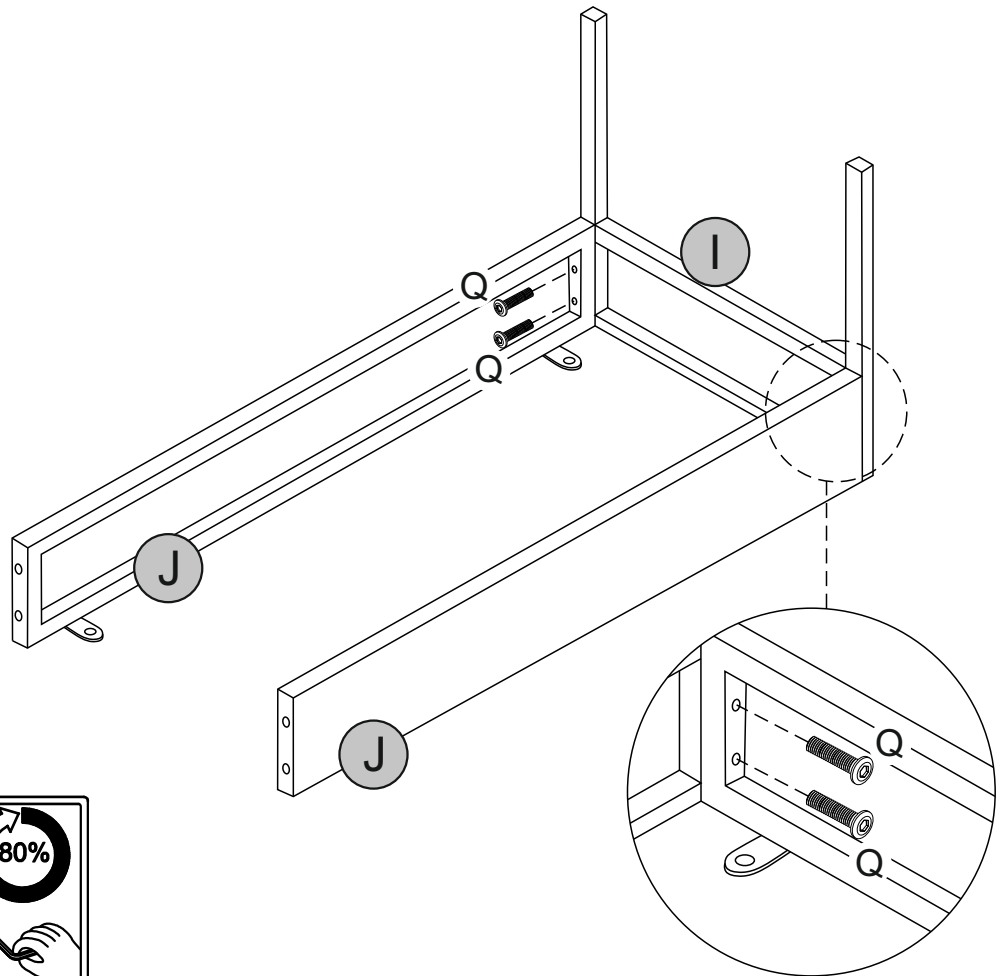

STEP 12

PARTS REQUIRED

I - TABLE FRAME (LEGS) x1

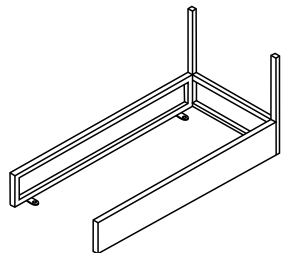

HARDWARE REQUIRED

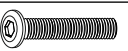
Q  04

TOOLS REQUIRED

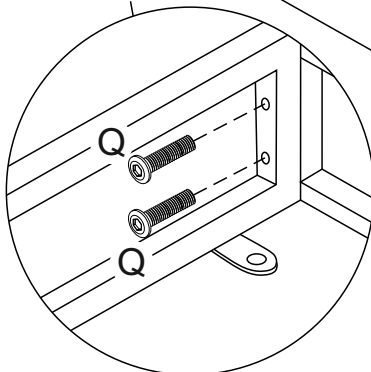
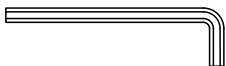

DO NOT FULLY TIGHTEN THE BOLTS AT THIS STAGE !!

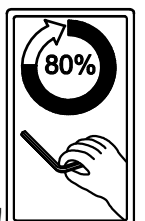

STEP 13

PARTS REQUIRED

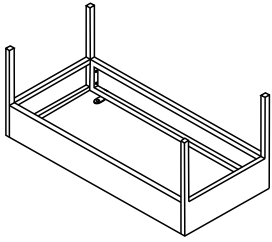

HARDWARE REQUIRED

TOOLS REQUIRED

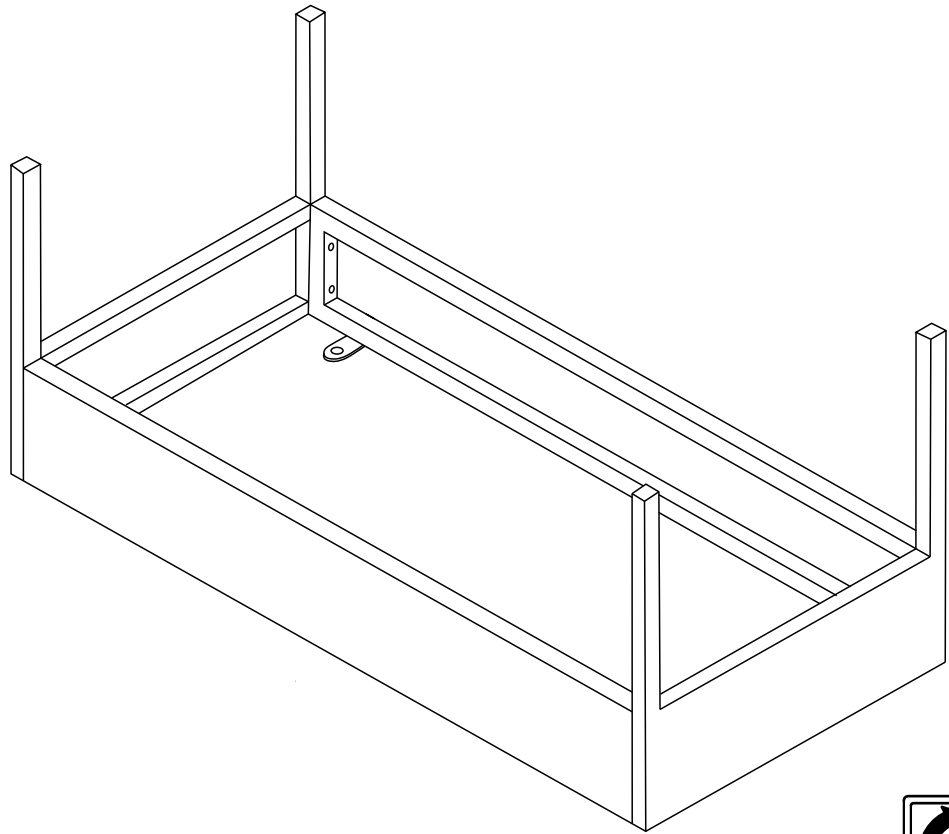

NOW FULLY TIGHTEN ALL THE BOLTS !!

STEP 14

PARTS REQUIRED

K - TABLE TOP x1

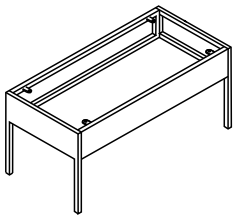

HARDWARE REQUIRED

S  04

TOOLS REQUIRED

